

Material Composition Declaration

Tantalum Capacitors



Remarks:

- KEMET Electronics Corporation Material Composition Declarations are based on raw material data and manufacturing processes in use at the time and date of declaration. The information provided is business confidential prepared exclusively for business purposes and must not be printed, copied, distributed or disclosed without prior written consent and authorization from KEMET Electronics Corporation.
- KEMET ACCEPTS NO DUTY TO NOTIFY USERS ABOUT CHANGES TO A MATERIAL DECLARATION. KEMET IS NOT LIABLE FOR ANY DAMAGES, DIRECT OR INDIRECT, CONSEQUENTIAL OR OTHERWISE, THAT THE READER MIGHT INCUR AS A RESULT OF IGNORING THIS WARNING, OR THAT ANY THIRD PARTY MIGHT SUFFER AS A RESULT OF THE READER'S IGNORING THIS WARNING.
- Miscellaneous refers to substances that are below of 0.1% by weight and are not restricted and/or banned substances based on IMDS reportable substance/ban list.
- Values (%) are based on engineering calculations and do not represent exact amount contained in product.
- All statements herein are based in our present knowledge. If products are used properly, there are no risks to humans and/or the environment.
- KEMET reserves the right to change and/or update this information without notification.
- KEMET's web site will be maintained updated to show the most current data.
- <https://www.kemet.com/en/us/rohs-documents.html>

Material Declaration

Tantalum MnO2 Surface Mount Capacitor(T49X series)

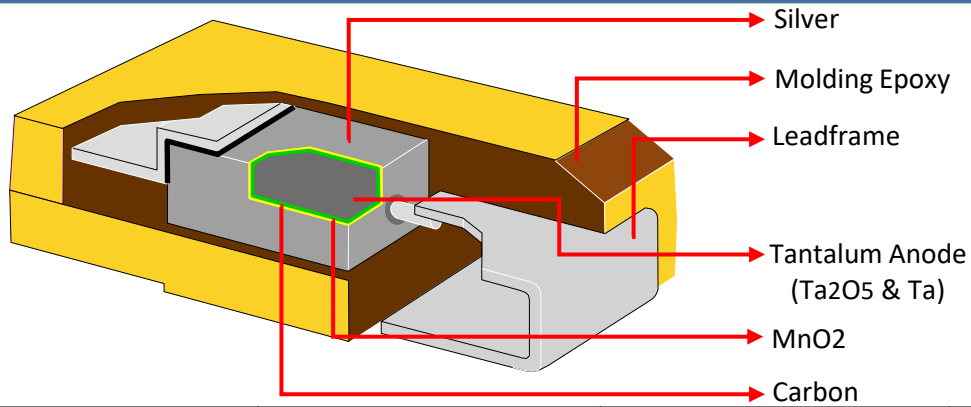

Environmental Compliance	
Pb Free	YES
RoHS Compliant	YES
Halogen Free	YES

Homogeneous Level	Construction Element	Substance	Weight	Common Name	CAS #	SGS Report No.
Anode	Tantalum Anode	Tantalum	See Annex 6	Ta	7440-25-7	SHAEC2120770101 ETR21A05683
		Tantalum pentoxide		Ta ₂ O ₅	1314-61-0	
	Manganese dioxide	Manganese dioxide		MnO ₂	1313-13-9	ETR21A05679
	Carbon	Carbon		C	7440-44-0	ETR21A05680
	Silver	Silver		Ag	7440-22-4	ETR21B04094
Leadframe	Leadframe	Alloy		Cu	7440-50-8	ETR21A05685
				Fe	7439-89-6	
				Zn	7440-66-6	
				Ni	7440-02-0	
				Sn	7440-31-5	
			Ag	7440-22-4		
Molding Epoxy	Molding Epoxy	Epoxy				ETR21A05681

Annex 1

Material Declaration

Tantalum MnO₂ Surface Mount Capacitor(T49X series)



Series				T49X					
Case code				A(3216-18)	B(3528-21)	C(6032-28)	D(7343-31)	X(7343-43)	V(7343-20)
Homogeneous Level	Material	Substance	CAS No.	weight [mg]	weight [mg]	weight [mg]	weight [mg]	weight [mg]	weight [mg]
Anode	Tantalum	Ta	7440-25-7	9.17	22.02	56.00	109.01	180.24	61.38
	Manganese dioxide	MnO ₂	1313-13-9	7.81	14.45	28.23	44.64	65.89	36.80
	Carbon	C	7440-44-0	0.10	0.07	0.14	0.29	0.48	0.19
	Silver	Ag	7440-22-4	1.41	2.60	5.07	8.00	11.90	6.61
	Fluorine	F	7782-41-4	0.23	0.06	0.11	0.38	0.20	0.15
	Miscellaneous		-	0.01	0.02	0.05	0.07	0.30	0.04
Homogeneous Level Weight				18.73	39.22	89.60	162.39	259.01	105.17
Leadframe	Base metal	Cu	7440-50-8	7.85	7.85	7.85	19.32	19.32	19.32
		Fe	7439-89-6	0.03	0.03	0.03	0.08	0.08	0.08
		Zn	7440-66-6	2.09	2.09	2.09	5.13	5.13	5.13
		Miscellaneous	-	0.09	0.09	0.09	0.23	0.24	0.23
	Under layer	Ni	7440-02-0	2.33	2.33	2.33	5.74	5.74	5.74
	Finish plating	Sn	7440-31-5	1.22	1.22	1.22	3.01	3.01	3.01
	Conductive Adhesive*	Ag	7440-22-4	4.90	4.90	4.90	12.05	12.05	12.05
		C	7440-44-0	1.21	1.21	1.21	2.97	2.97	2.97
Homogeneous Level Weight				19.72	19.72	19.72	48.53	48.54	48.53
Molding Epoxy	Molding Epoxy	SiO ₂	7631-86-9	15.58	32.92	87.23	152.93	211.06	93.82
		Carbon	7440-44-0	4.10	8.67	22.98	40.28	55.59	24.71
		Iron	7439-89-6	0.15	0.33	0.86	1.51	2.08	0.93
		Miscellaneous	-	0.69	1.44	3.81	6.69	9.22	4.10
Homogeneous Level Weight				20.52	43.36	114.88	201.41	277.95	123.56
Total Weight				58.97	102.30	224.20	412.33	585.50	277.26

* This was tested as part of the Leadframe Finish Plating.

Material Declaration

Tantalum MnO₂ Surface Mount Capacitor(T51X series)

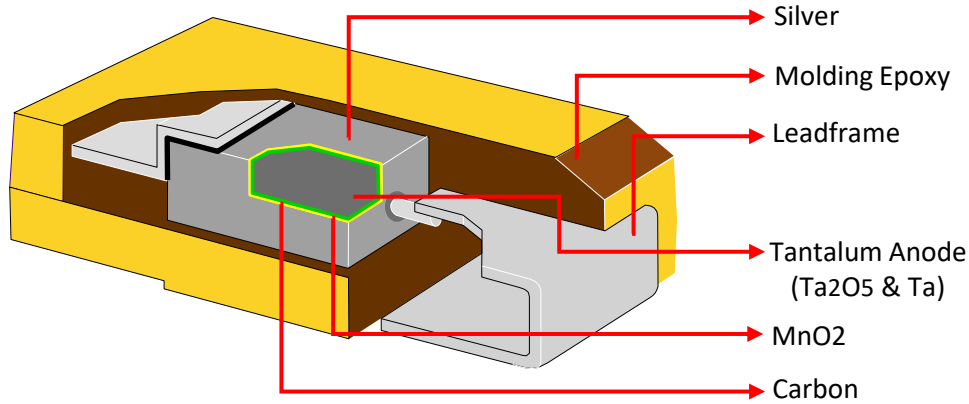

Environmental Compliance	
Pb Free	YES
RoHS Compliant	YES
Halogen Free	YES

Homogeneous Level	Construction Element	Substance	Weight	Common Name	CAS #	SGS Report No.
Anode	Tantalum Anode	Tantalum	See Annex 7	Ta	7440-25-7	SHAEC2120770101 ETR21A05683
		Tantalum pentoxide		Ta ₂ O ₅	1314-61-0	
	Manganese dioxide	Manganese dioxide		MnO ₂	1313-13-9	ETR21A05679
	Carbon	Carbon		C	7440-44-0	ETR21A05680
	Silver	Silver		Ag	7440-22-4	ETR21B04094
Leadframe	Leadframe	Alloy		Cu	7440-50-8	ETR21B00953
				Zn	7440-66-6	
				Ni	7440-02-0	
				Sn	7440-31-5	
				Ag	7440-22-4	
Molding Epoxy	Molding Epoxy	Epoxy				ETR21A05684

Annex 2

Material Declaration

Tantalum MnO₂ Surface Mount Capacitor(T51X series)



Series				T51X	
Case code				E (7360-38)	X (7343-43)
Homogeneous Level	Material	Substance	CAS No.	weight [mg]	weight [mg]
Anode	Tantalum	Ta	7440-25-7	67.66	67.66
	Manganese dioxide	MnO ₂	1313-13-9	39.21	39.21
	Carbon	C	7440-44-0	0.22	0.20
	Silver	Ag	7440-22-4	7.05	7.05
	Miscellaneous	-	-	0.29	0.21
Homogeneous Level Weight				114.43	114.33
Leadframe	Base metal	Cu	7440-50-8	19.32	19.32
		Zn	7440-66-6	5.13	5.12
		Miscellaneous	-	0.31	0.28
	Under layer	Ni	7440-02-0	5.74	5.74
	Finish plating	Sn	7440-31-5	3.01	3.01
		Conductive Adhesive*	Ag	7440-22-4	12.05
		C	7440-44-0	2.97	0.77
Homogeneous Level Weight				48.53	37.38
Molding Epoxy	Molding Epoxy	SiO ₂	7631-86-9	256.48	211.35
		Carbon	7440-44-0	67.56	55.67
		Iron	7439-89-6	2.53	2.09
		Miscellaneous	-	11.21	9.23
Homogeneous Level Weight				337.78	278.34
Total Weight				500.74	430.05

* This was tested as part of the Leadframe Finish Plating.

Material Declaration

Tantalum Polymer Surface Mount Capacitor(T52X series)

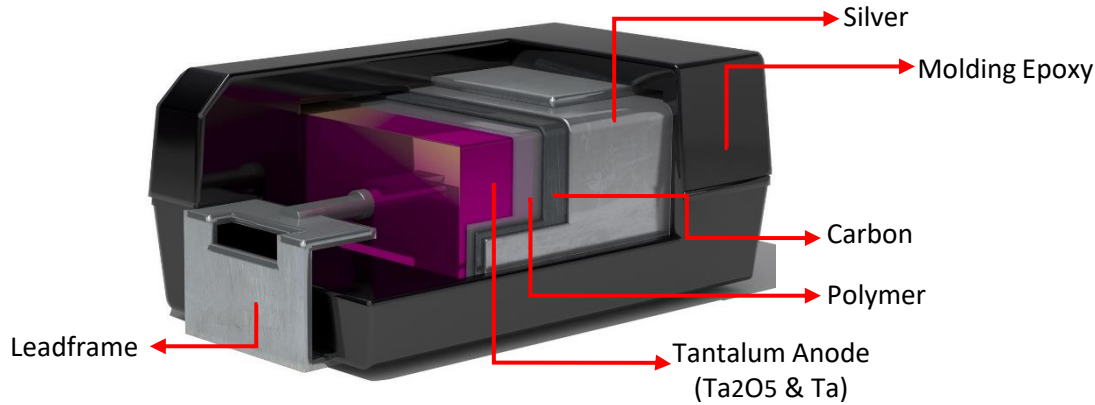

Environmental Compliance	
Pb Free	YES
RoHS Compliant	YES
Halogen Free	YES

Homogeneous Level	Construction Element	Substance	Weight	Common Name	CAS #	SGS Report No.
Anode	Tantalum Anode	Tantalum	See Annex 8	Ta	7440-25-7	SHAEC2120770101 ETR21A05683
		Tantalum Pentoxide		Ta ₂ O ₅	1314-61-0	
	Polymer	Polymer				SHAEC2120770102
	Carbon	Carbon		C	7440-44-0	SHAEC2120770106
	Silver	Silver		Ag	7440-22-4	SHAEC2120770111
Leadframe	Leadframe	Alloy		Cu	7440-50-8	SHAEC2120770116
				Fe	7439-89-6	
				Zn	7440-66-6	
				Sn	7440-31-5	
				Ag	7440-22-4	
Molding Epoxy	Molding Epoxy	Epoxy				SHAEC2120770119

Annex 3

Material Declaration

Tantalum Polymer Surface Mount Capacitor(T52X series)



Series				T52x									
Case code				A (3216-18)	B (3528-21)	C (6032-28)	D (7343-31)	U (6032-15)	V (7343-19)	W (7343-15)	X (7343-43)	Y (7343-40)	
Homogeneous Level	Material	Substance	CAS No.	weight [mg]	weight [mg]	weight [mg]	weight [mg]	weight [mg]	weight [mg]	weight [mg]	Weight [mg]	Weight [mg]	
Anode	Tantalum	Ta ₂ O ₅	7440-25-7	9.50	25.99	39.99	129.75	28.19	69.27	61.48	203.01	153.44	
	Polymer	-	-	0.47	0.92	1.46	3.08	1.24	2.43	2.46	3.82	3.08	
	Carbon	C	7440-44-0	0.44	0.85	1.36	5.59	2.39	4.41	4.76	3.54	5.59	
	Silver	Ag	7440-22-4	1.45	2.81	4.47	10.71	3.79	8.45	7.55	11.69	10.71	
	Fluorine	F	7782-41-4	0.61	1.20	1.90	0.00	0.38	0.00	0.75	4.99	0.00	
	Miscellaneous		-	-	0.01	0.01	0.02	0.06	0.01	0.04	0.03	0.09	0.06
Homogenous Level Weight				12.48	31.78	49.20	149.19	36.00	84.60	77.03	227.14	172.88	
Lead frame	Base metal	Cu	7440-50-8	11.92	11.92	11.92	29.34	11.92	29.34	29.34	29.34	29.34	
		Zn	7440-66-6	0.02	0.02	0.02	0.05	0.02	0.05	0.05	0.05	0.05	
		Fe	7439-89-6	0.29	0.29	0.29	0.71	0.29	0.71	0.71	0.71	0.71	
		Miscellaneous	-	0.03	0.03	0.03	0.06	0.03	0.06	0.06	0.06	0.06	
	Under layer	Cu	7440-50-8	0.12	0.12	0.12	0.30	0.12	0.30	0.30	0.30	0.30	
	Finish plating	Sn	7440-31-5	1.23	1.23	1.23	3.01	1.23	3.01	3.01	3.01	3.01	
	Conductive Adhesive*	Ag	7440-22-4	4.90	4.90	4.90	12.05	4.90	12.05	12.05	12.05	12.05	12.05
		C	7440-44-0	1.21	1.21	1.21	2.97	1.21	2.97	2.97	2.97	2.97	2.97
Homogenous Level Weight				19.72	19.72	19.72	48.53	19.72	48.53	48.53	48.53	48.53	
Molding Epoxy	Molding Epoxy	SiO ₂	7631-86-9	15.97	33.73	89.68	156.45	47.98	96.06	75.81	216.63	202.49	
		C	7440-44-0	2.22	4.69	12.47	21.75	6.67	13.35	10.54	30.11	28.15	
		Magnesium	7439-95-4	1.86	3.92	10.42	18.17	5.57	11.16	8.80	25.16	23.52	
		Miscellaneous	-	0.47	1.00	2.65	4.62	1.42	2.84	2.24	6.40	5.98	
Homogenous Level Weight				20.52	43.34	115.22	200.99	61.64	123.41	97.39	278.30	260.14	
Total				52.72	94.84	184.14	398.71	117.36	256.54	222.95	553.97	481.55	

* This was tested as part of the Leadframe Finish Plating.

Material Declaration

Tantalum Polymer Surface Mount Capacitor(T53X series)



a YAGEO company

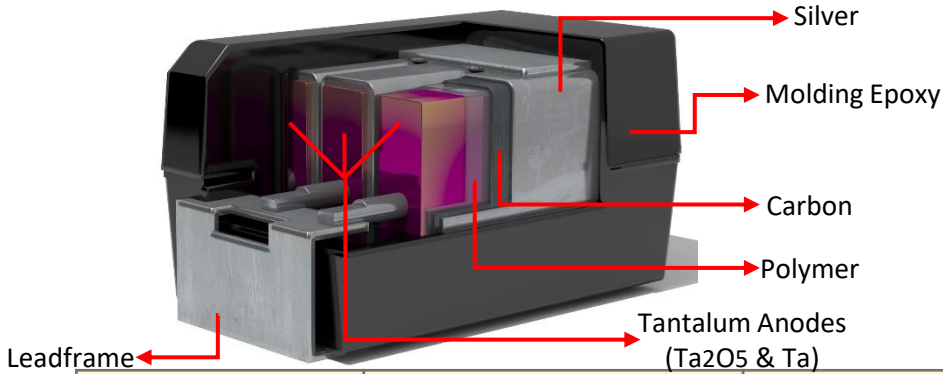

Environmental Compliance	
Pb Free	YES
RoHS Compliant	YES
Halogen Free	YES

Homogeneous Level	Construction Element	Substance	Weight	Common Name	CAS #	SGS Report No.
Anode	Tantalum Anode	Tantalum	See Annex 9	Ta	7440-25-7	SHAEC2120770101 ETR21A05683
		Tantalum Pentoxide		Ta2O5	1314-61-0	
	Polymer	Polymer				SHAEC2120770103
	Carbon	Carbon		C	7440-44-0	SHAEC2120770106
	Silver	Silver		Ag	7440-22-4	SHAEC2120770111
Leadframe	Leadframe	Alloy		Cu	7440-50-8	SHAEC2120770116
				Fe	7439-89-6	
				Zn	7440-66-6	
				Pd	7440-05-3	
				Sn	7440-31-5	
Molding Epoxy	Molding Epoxy	Epoxy	Ag	7440-22-4	SHAEC2120770119	

Annex 4

Material Declaration

Tantalum Polymer Surface Mount Capacitor (T53X series)



Series				T53X		
Case code				D (7343-31)	X (7343-43)	Y (7343-40)
Homogeneous Level	Material	Substance	CAS No.	Weight [mg]	Weight [mg]	Weight [mg]
Anode	Tantalum	Ta ₂ O ₅	7440-25-7	59.28	78.77	66.87
	Polymer	-	-	1.77	2.41	2.41
	Carbon	C	7440-44-0	1.64	2.23	2.23
	Silver	Ag	7440-22-4	5.41	7.37	7.37
	Fluorine	F	7782-41-4	2.30	3.15	3.15
	Miscellaneous		-	-	0.03	0.03
Homogenous Level Weight				70.43	93.96	82.06
Leadframe	Base Metal	Cu	7440-50-8	29.34	29.34	29.34
		Fe	7439-89-6	0.71	0.71	0.71
		Zn	7440-66-6	0.05	0.05	0.05
		Miscellaneous	-	0.04	0.06	0.06
	Under layer	Pd	7440-05-3	0.30	0.30	0.30
	Finish plating	Sn	7440-31-5	3.02	3.01	3.01
	Conductive Adhesive*	Ag	7440-22-4	1.66	3.14	3.14
C		7440-44-0	0.41	0.77	0.77	
Homogenous Level Weight				35.53	37.38	37.38
Molding Epoxy	Molding Epoxy	SiO ₂	7631-86-9	156.88	216.66	201.31
		C	7440-44-0	21.81	30.12	27.98
		Magnesium	7439-95-4	18.22	25.16	23.38
		Miscellaneous	-	4.64	6.40	5.95
Homogenous Level Weight				201.55	278.34	258.62
Total				307.51	409.68	378.06

* This was tested as part of the Leadframe Finish Plating.