

BGSA12UGL8

Low Resistance SPDT Antenna Aperture Switch

Features

- SPDT designed for high-linearity antenna aperture switching and RF tuning applications
- Ultra low R_{ON} resistance of 0.59Ω at each port in ON state
- Low C_{OFF} capacitance of 270 fF at each port in OFF state
- > 40V RF voltage OFF state handling
- Low harmonic generation
- Supply voltage range: 1.65 to 3.6 V
- Small form factor 1.1mmx 1.1mm
- Suitable for EDGE/ CDMA/WCDMA/ C2K/ LTE Applications
- RoHS and WEEE compliant package

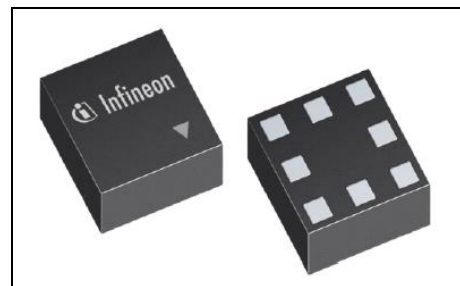

Description

The BGSA12UGL8 is a versatile Single Pole Double Throw (SPDT) RF antenna aperture switch optimized for low C_{off} as well as low R_{on} enabling applications up to 6.0 GHz. This single supply chip integrates with a 2 bits control logic featuring also a low current standby mode. Unlike GaAs technology, the 0.1 dB compression point exceeds the switch maximum input power level, resulting in linear performance at all signal levels and external DC blocking capacitors at the RF ports are only required if DC voltage is applied externally. Due to its very high RF voltage ruggedness, it is suited for switching any reactive devices such as inductors and capacitors in RF matching circuits without significant losses in quality factors.

Block diagram and ordering information

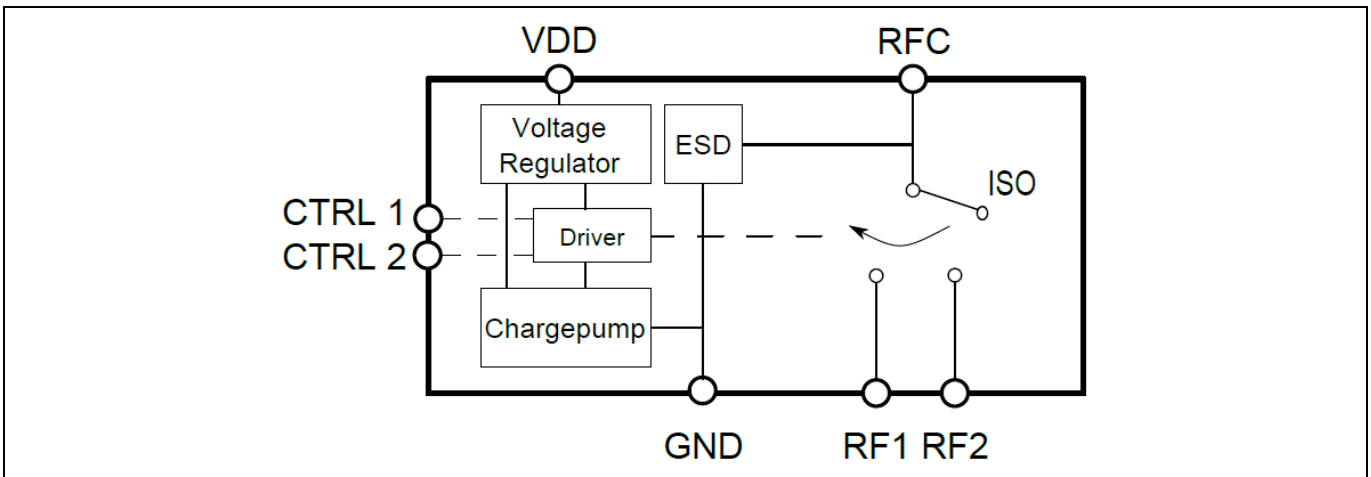

Figure 1 BGSA12UGL8 Block diagram

Table 1 Ordering Information

Type	Package	Marking
BGSA12UGL8	TSLP-8-1	A



WEEE Compliant Package



Halogen-Free PB Free



RoHS

Trademarks

All referenced product or service names and trademarks are the property of their respective owners.

Edition 2018-11-15

Published by

Infineon Technologies AG

81726 München, Germany

© 2018 Infineon Technologies AG.

All Rights Reserved.

Do you have a question about this document?

Email: erratum@infineon.com

Document reference

ifx1

IMPORTANT NOTICE

The information given in this document shall in no event be regarded as a guarantee of conditions or characteristics ("Beschaffenheitsgarantie").

With respect to any examples, hints or any typical values stated herein and/or any information regarding the application of the product, Infineon Technologies hereby disclaims any and all warranties and liabilities of any kind, including without limitation warranties of non-infringement of intellectual property rights of any third party.

In addition, any information given in this document is subject to customer's compliance with its obligations stated in this document and any applicable legal requirements, norms and standards concerning customer's products and any use of the product of Infineon Technologies in customer's applications.

The data contained in this document is exclusively intended for technically trained staff. It is the responsibility of customer's technical departments to evaluate the suitability of the product for the intended application and the completeness of the product information given in this document with respect to such application.

For further information on the product, technology, delivery terms and conditions and prices please contact your nearest Infineon Technologies office (www.infineon.com).

WARNINGS

Due to technical requirements products may contain dangerous substances. For information on the types in question please contact your nearest Infineon Technologies office.

Except as otherwise explicitly approved by Infineon Technologies in a written document signed by authorized representatives of Infineon Technologies, Infineon Technologies' products may not be used in any applications where a failure of the product or any consequences of the use thereof can reasonably be expected to result in personal injury.