

3M™ Active Optical Cable (AOC) Assemblies for CX4 Applications
 Visit <http://www.3Mconnectors.com>

REVISION RECORD		
REV.	ECR/ECN/ECO NUMBER	DATE
B	ECR/ECO-0043565	28/09/12

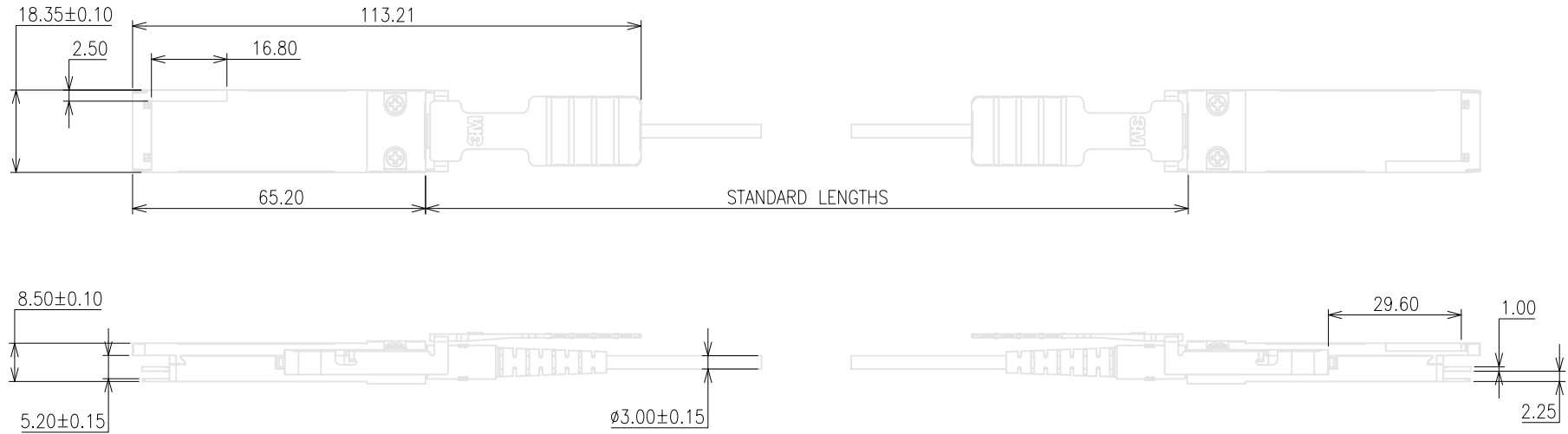

NOTES:

- HOUSING MATERIAL: ZINC ALLOY
FINISH: NICKEL PLATING
- CABLE: ORANGE OM2+, PLENUM RATED THERMOPLASTIC OR ORANGE OM2+, LOW SMOKE ZERO HALOGEN RATED THERMOPLASTIC (LSZH)

PART NUMBERS

6A22-A04X1-XXX.0-0

- STANDARD LENGTHS: 1 m INCREMENTS FROM 2m TO 30m, 35m, 40m, 45m, 50m, 60m, 70m, 80m, 90m, 100m
- CABLE TYPE: 2 PLENUM
4 LOW SMOKE ZERO HALOGEN (LSZH)

PART NUMBER	DESCRIPTION
example: 6A22-A0421-003.0-0	AOC, QSFP-QSFP, QDR, 4CH, PLENUM, OM2+, 3m

CABLE LENGTH	TOLERANCE
<10m	+40cm/-20cm
10m to 50m	+40cm/-30cm
>50m	+40cm/-50cm

UNIT: MM	DFTG	OH KIM CHYE	DATE 28/09/12	3M APAC INNOVATION CENTRE	DIVISION	ESD	STATUS RELEASED
GEN. TOLERANCES	CHKD	SAUJIT BANDHU	DATE 28/09/12		MODEL		
LINEAR .0 = ± 0.20 .00 = ± 0.10 .000 = ± 0.05	APPVL	ALAN ANG	DATE 28/09/12	TITLE AOC, QSFP-QSFP, QDR, 4CH OPTICAL CABLE			
ANGLE ±1°	THIS DOCUMENT CONTAINS INFORMATION WHICH IS PROPRIETARY TO 3M COMPANY. NO REPRODUCTION OR PUBLICATION OF THIS DOCUMENT, IN WHOLE OR IN PART, SHALL BE MADE WITHOUT AUTHORIZATION FROM 3M. ©3M 2012. ALL RIGHTS RESERVED.			SIZE A3	DRAWING NO. 78-5100-2442-1	REV B	
PROJECTION	INTERPRET PER ASME Y14.5M-1994			SCALE : 1:1	DET LIST	<input type="checkbox"/> YES <input type="checkbox"/> NO	SHT 1 of 1
	CRITICAL DIMENSION: ▲						