

DRAWING FOR REFERENCE: This is subject to change without notice
08/11/2012

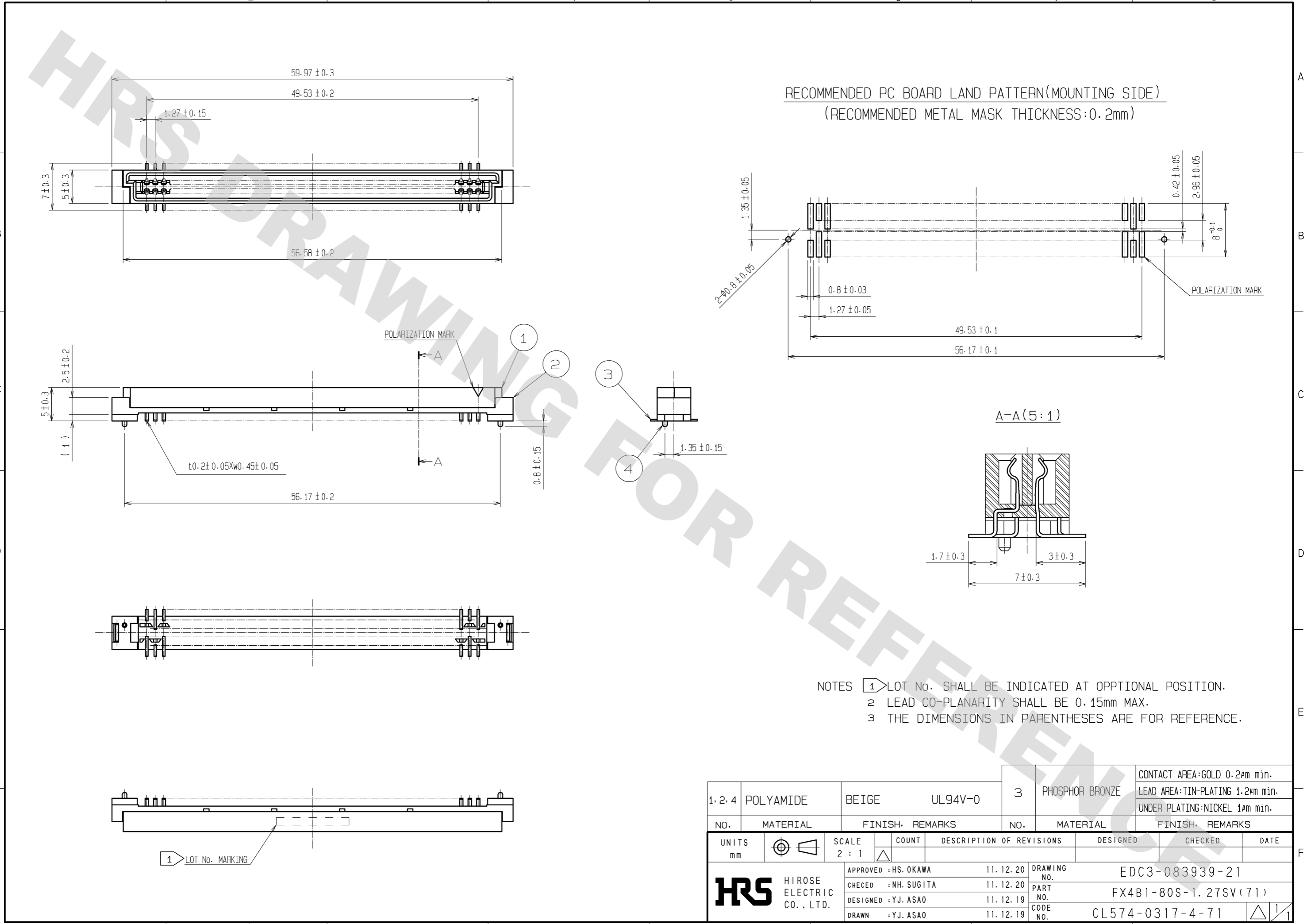

1.2.4	POLYAMIDE	BEIGE	UL94V-0	3	PHOSPHOR BRONZE	CONTACT AREA:GOLD 0.2µm min. LEAD AREA:TIN-PLATING 1.2µm min. UNDER PLATING:NICKEL 1µm min.		
NO.	MATERIAL	FINISH	REMARKS	NO.	MATERIAL	FINISH	REMARKS	
UNITS mm		SCALE 2:1	COUNT 	DESCRIPTION OF REVISIONS		DESIGNED	CHECKED	DATE
HRS HIROSE ELECTRIC CO., LTD.		APPROVED : HS. OKAWA	11.12.20	DRAWING NO.		EDC3-083939-21		
		CHECED : NH. SUGITA	11.12.20	PART NO.		FX4B1-80S-1.27SV(71)		
		DESIGNED : YJ. ASAO	11.12.19	CODE NO.		CL574-0317-4-71		
		DRAWN : YJ. ASAO	11.12.19					