

DRAWING FOR REFERENCE: This is subject to change without notice
08/11/2012

RECOMMENDED PATTERN

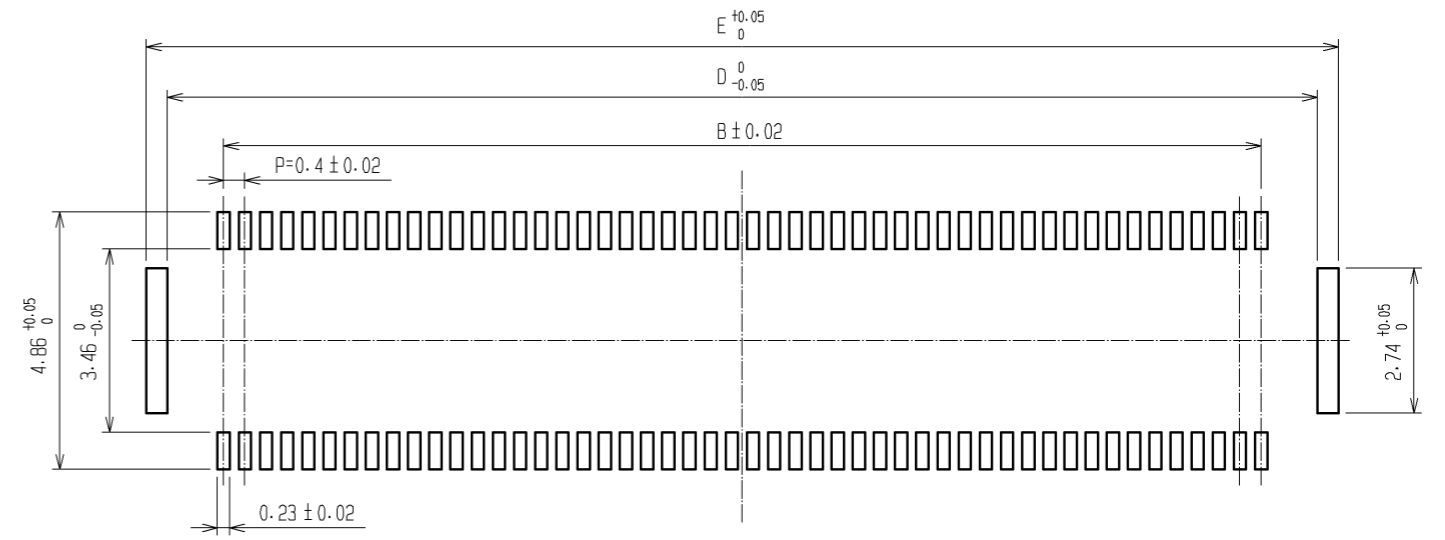

RECOMMENDED SOLDER PASTE: THICKNESS 120#m

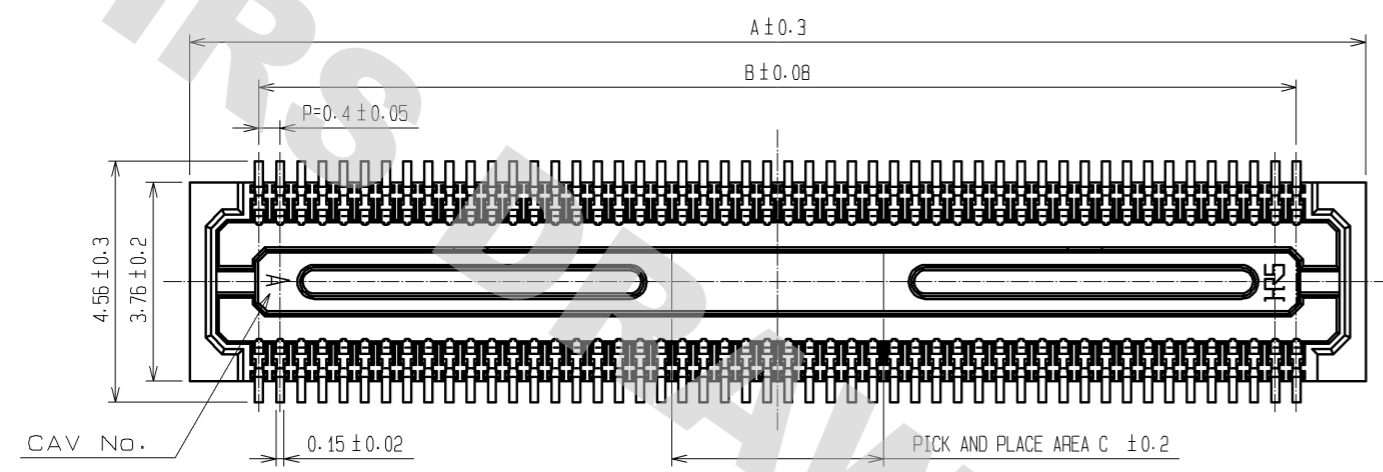
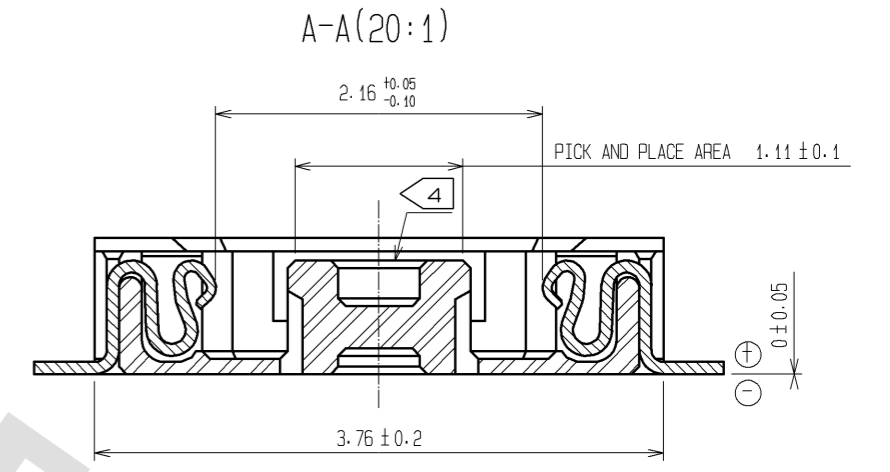
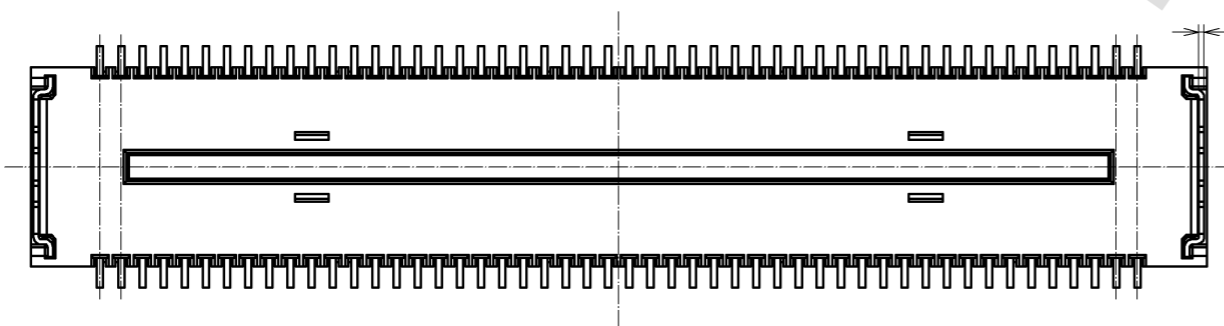
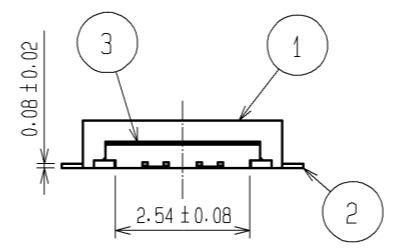
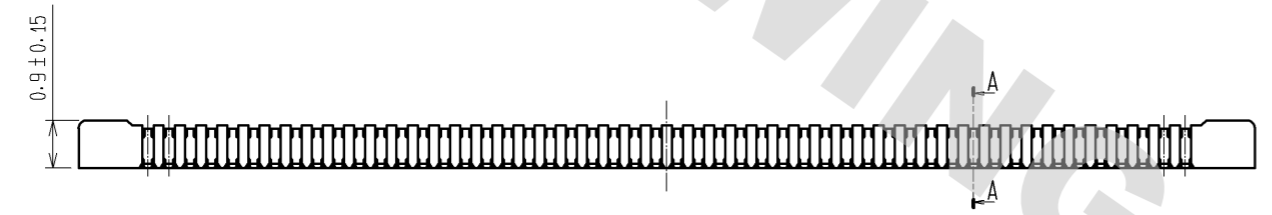

- NOTE 1. ALL LEADS CO-PLANARITY SHALL BE 0.1 MAX.
 2. PER REEL : 1000 CONNECTORS.
 3. AT THE BEGINNING OF THE REEL, 100 mm AT MIN SHALL BE EMPTY POCKETS.
 AT THE END OF THE REEL, 160 mm AT MIN SHALL BE EMPTY.
 4 NO CAVITY ON THE CONNECTORS LESS THAN 24 POS.
 5 CONTACT PLATING SPECIFICATIONS.
 CONTACT AREA : GOLD 0.05#m MIN.
 SMT LEAD : GOLD 0.02#m MIN.
 UNDERPLATING : NICKEL 1#m MIN.
 (SURFACE : SEALING)
 6 METAL HOLD DOWN PLATING SPECIFICATIONS.
 MOUNTING AREA: TIN 1#m MIN.
 UNDERPLATING : NICKEL 1#m MIN.
 7. PEEL FORCE REFERS TO JIS C 0806.

PART NO.	A	B	C	D	E
DF30FB- 80DS-0.4V(82)	18.22	15.6	3.2	17.72	18.52
DF30FB- 70DS-0.4V(82)	16.22	13.6	2.8	15.72	16.52
DF30FB- 60DS-0.4V(82)	14.22	11.6	2.4	13.72	14.52
DF30FB- 50DS-0.4V(82)	12.22	9.6	2	11.72	12.52
DF30FB- 40DS-0.4V(82)	10.22	7.6	1.6	9.72	10.52
DF30FB- 34DS-0.4V(82)	9.02	6.4	1.36	8.52	9.32
DF30FB- 30DS-0.4V(82)	8.22	5.6	1.2	7.72	8.52
DF30FB- 24DS-0.4V(82)	7.02	4.4	1.2	6.52	7.32
DF30FB- 22DS-0.4V(82)	6.62	4.0	1.2	6.12	6.92
DF30FB- 20DS-0.4V(82)	6.22	3.6	1.2	5.72	6.52

NO.	MATERIAL	FINISH	REMARKS	NO.	MATERIAL	FINISH	REMARKS
3	PHOSPHOR BRONZE	6		6	PS		PLASTIC REEL (BLACK)
2	PHOSPHOR BRONZE	5		5	POLYESTER		CLEAR (COVER TAPE)
1	LCP		UL94V-0, BLACK	4	PS		CLEAR (EMBOSSED CARRIER TAPE)

UNITS	SCALE	COUNT	DESCRIPTION OF REVISIONS	DESIGNED	CHECKED	DATE
mm	FREE	2	DIS-H-005343	TK. SUZUKI	AR. TAKAHASHI	10.11.30

APPROVED	DATE	DRAWING NO.
MO. NAKAMURA	05.09.30	EDC3-303547-04
CHECKED	DATE	PART NO.
TS. MIYAZAKI	05.09.29	DF30FB-*DS-0.4V(82)
DESIGNED	DATE	CODE NO.
AR. TAKAHASHI	05.09.29	CL684-
DRAWN	DATE	
AR. TAKAHASHI	05.09.29	

DRAWING FOR REFERENCE: This is subject to change without notice
08/11/2012

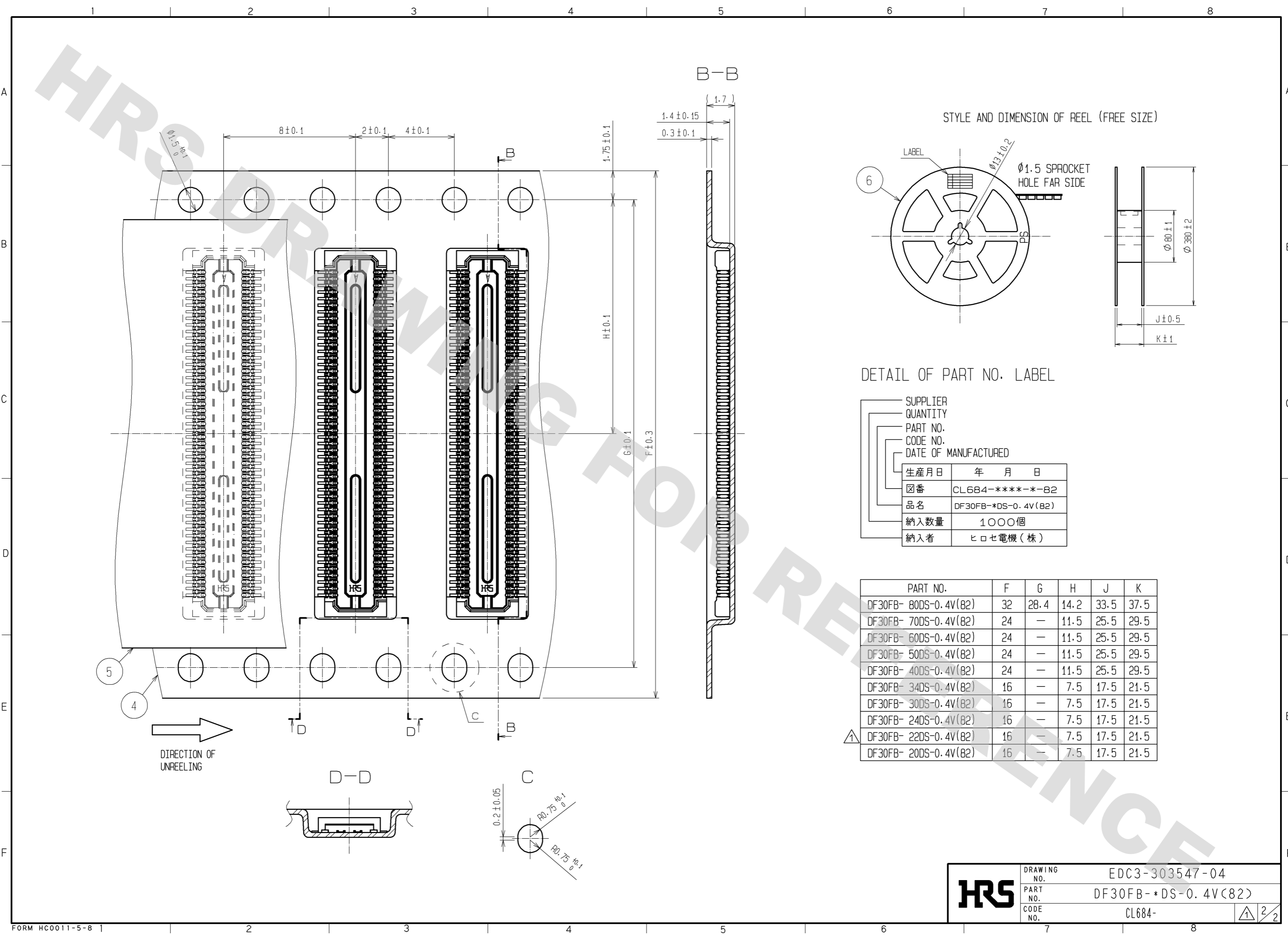

STYLE AND DIMENSION OF REEL (FREE SIZE)

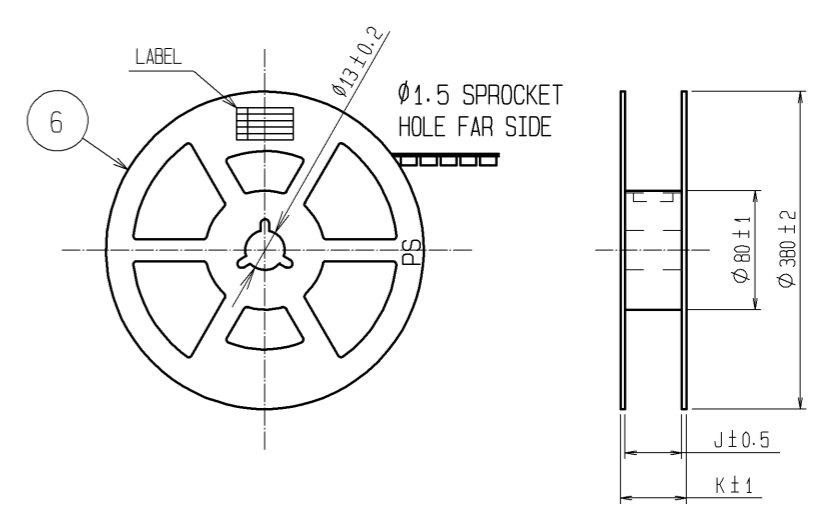

DETAIL OF PART NO. LABEL

PART NO.	F	G	H	J	K
DF30FB- 80DS-0.4V(82)	32	28.4	14.2	33.5	37.5
DF30FB- 70DS-0.4V(82)	24	—	11.5	25.5	29.5
DF30FB- 60DS-0.4V(82)	24	—	11.5	25.5	29.5
DF30FB- 50DS-0.4V(82)	24	—	11.5	25.5	29.5
DF30FB- 40DS-0.4V(82)	24	—	11.5	25.5	29.5
DF30FB- 34DS-0.4V(82)	16	—	7.5	17.5	21.5
DF30FB- 30DS-0.4V(82)	16	—	7.5	17.5	21.5
DF30FB- 24DS-0.4V(82)	16	—	7.5	17.5	21.5
DF30FB- 22DS-0.4V(82)	16	—	7.5	17.5	21.5
DF30FB- 20DS-0.4V(82)	16	—	7.5	17.5	21.5

HRS

DRAWING NO. EDC3-303547-04

PART NO. DF30FB-*DS-0.4V(82)

CODE NO. CL684-

2/2