

DRAWING FOR REFERENCE: This is subject to change without notice
08/11/2012

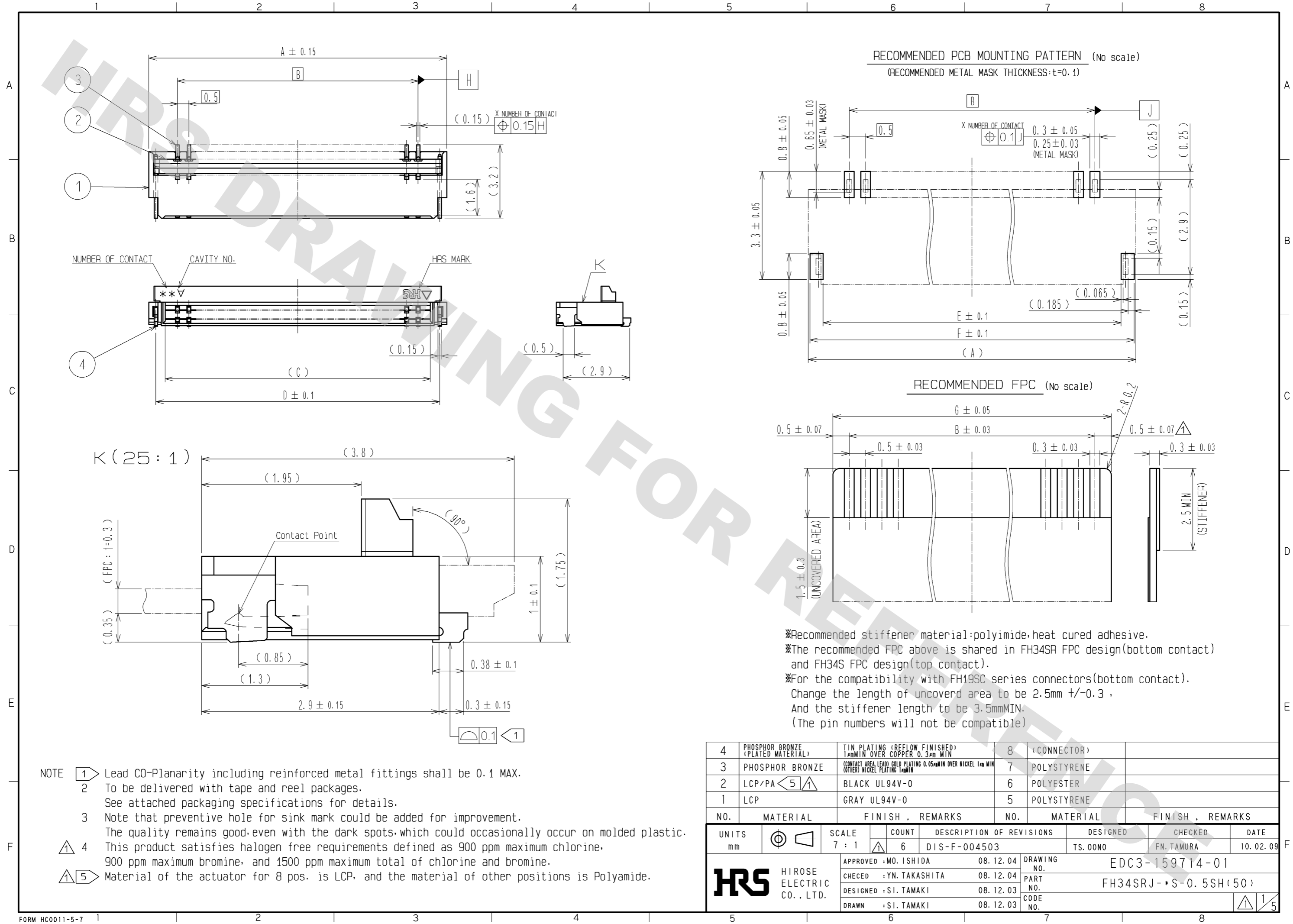

- NOTE
- ① Lead CO-Planarity including reinforced metal fittings shall be 0.1 MAX.
 - ② To be delivered with tape and reel packages. See attached packaging specifications for details.
 - ③ Note that preventive hole for sink mark could be added for improvement. The quality remains good, even with the dark spots, which could occasionally occur on molded plastic.
 - ④ This product satisfies halogen free requirements defined as 900 ppm maximum chlorine, 900 ppm maximum bromine, and 1500 ppm maximum total of chlorine and bromine.
 - ⑤ Material of the actuator for 8 pos. is LCP, and the material of other positions is Polyamide.

※Recommended stiffener material: polyimide, heat cured adhesive.
 ※The recommended FPC above is shared in FH34SR FPC design (bottom contact) and FH34S FPC design (top contact).
 ※For the compatibility with FH19SC series connectors (bottom contact). Change the length of uncovered area to be 2.5mm +/- 0.3, and the stiffener length to be 3.5mm MIN. (The pin numbers will not be compatible)

4	PHOSPHOR BRONZE (PLATED MATERIAL)	TIN PLATING (REFLOW FINISHED) 1μm MIN OVER COPPER 0.3μm MIN	8	(CONNECTOR)				
3	PHOSPHOR BRONZE	(CONTACT AREA LEAD) GOLD PLATING 0.05μm MIN OVER NICKEL 1μm MIN (OTHER) NICKEL PLATING 1μm MIN	7	POLYSTYRENE				
2	LCP/PA	BLACK UL94V-0	6	POLYESTER				
1	LCP	GRAY UL94V-0	5	POLYSTYRENE				
NO.	MATERIAL	FINISH . REMARKS	NO.	MATERIAL	FINISH . REMARKS			
UNITS	mm	SCALE	7 : 1	COUNT	6			
		DESCRIPTION OF REVISIONS	DESIGNED	TS.00NO	CHECKED	FN. TAMURA	DATE	10.02.09
		APPROVED : MO. ISHIDA	08.12.04	DRAWING NO.		EDC3-159714-01		
		CHECED : YN. TAKASHITA	08.12.04	PART NO.		FH34SRJ-*S-0.5SH(50)		
		DESIGNED : SI. TAMAKI	08.12.03	CODE NO.				
		DRAWN : SI. TAMAKI	08.12.03					

EMBOSED CARRIER TAPE DIMENSION(2:1)

TAPE WIDTH: 24mmMAX

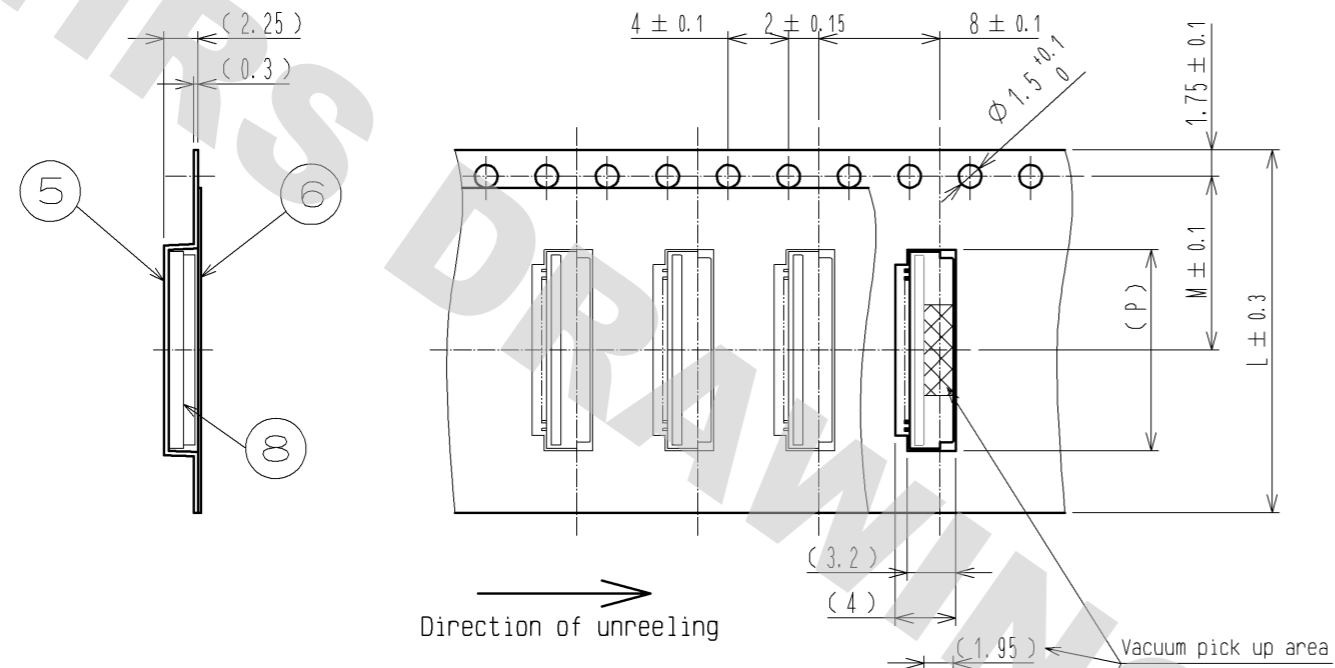

TAPE WIDTH: 32mmMIN

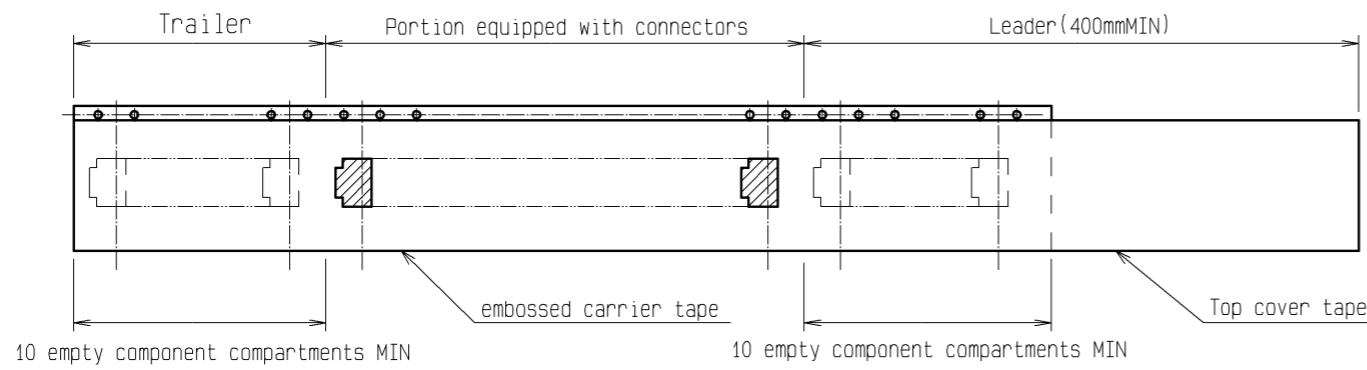
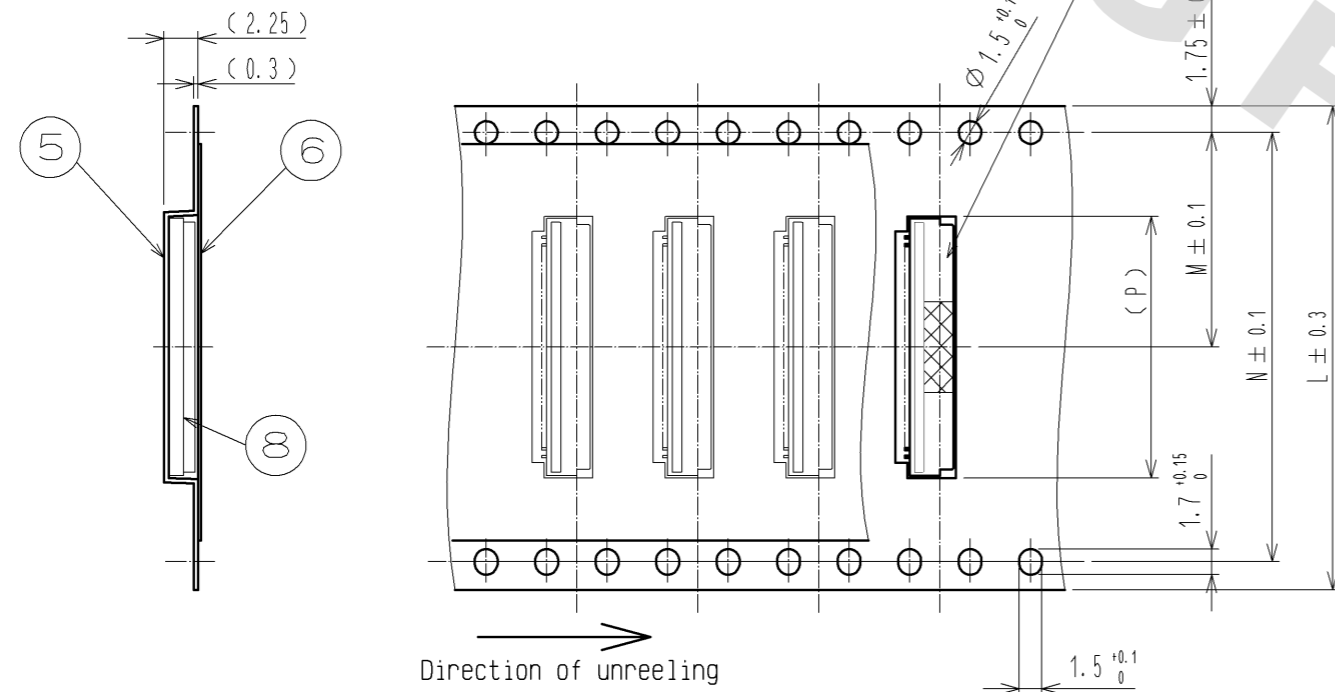

REEL DIMENSION (No scale)

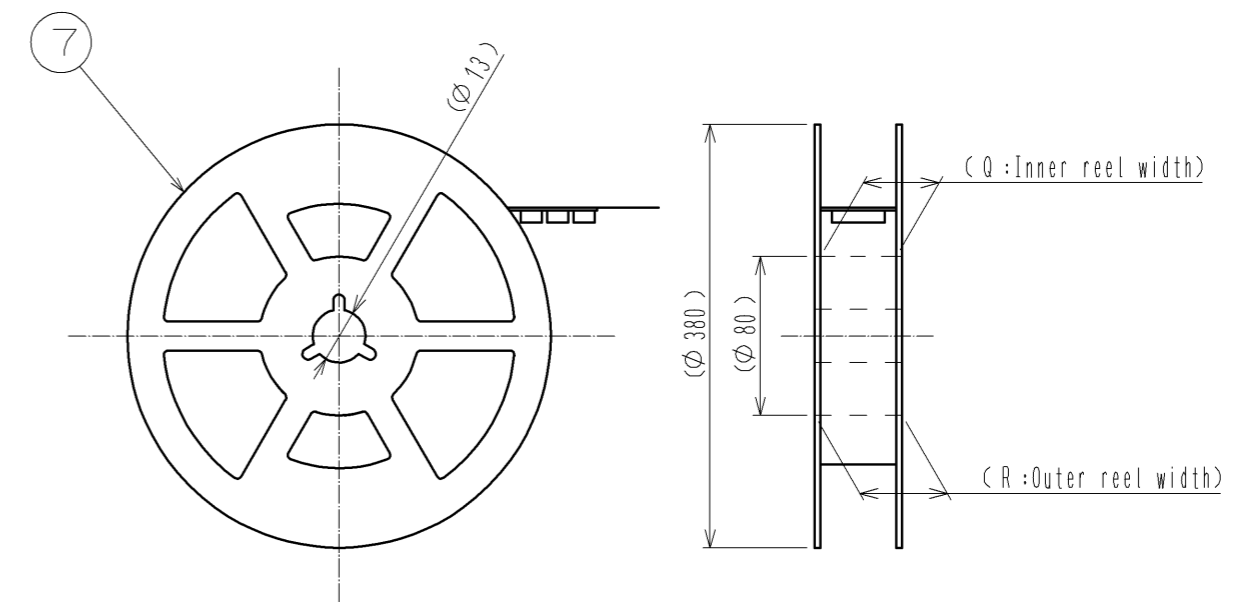

NOTE 6 The dimensions in parentheses are for reference.
 7 Per reel : 5000 connectors.
 8 Refer to JIS C 0806
 (Packaging of components for automatic handling.)

<DRAWING FOR PACKING>

HRS	DRAWING NO.	EDC3-159714-01
	PART NO.	FH34SRJ-*S-0.5SH(50)
	CODE NO.	

DRAWING FOR REFERENCE: This is subject to change without notice
08/11/2012

[DIMENSION TABLE OF CONNECTOR, FPC, LAND PATTERN AND METAL MASK] △

PART No.	CODE No.	*	A	B	C	D	E	F	G
FH34SRJ- 4S-0.5SH(50)	CL580-1238-7-50	4	4	1.5	2.53	3.38	3.1	3.9	2.5
FH34SRJ- 5S-0.5SH(50)	—	5	4.5	2	3.03	3.88	3.6	4.4	3
FH34SRJ- 6S-0.5SH(50)	CL580-1236-1-50	6	5	2.5	3.53	4.38	4.1	4.9	3.5
FH34SRJ- 7S-0.5SH(50)	—	7	5.5	3	4.03	4.88	4.6	5.4	4
FH34SRJ- 8S-0.5SH(50)	CL580-1231-8-50	8	6	3.5	4.53	5.38	5.1	5.9	4.5
FH34SRJ- 9S-0.5SH(50)	—	9	6.5	4	5.03	5.88	5.6	6.4	5
FH34SRJ-10S-0.5SH(50)	—	10	7	4.5	5.53	6.38	6.1	6.9	5.5
FH34SRJ-11S-0.5SH(50)	—	11	7.5	5	6.03	6.88	6.6	7.4	6
FH34SRJ-12S-0.5SH(50)	—	12	8	5.5	6.53	7.38	7.1	7.9	6.5
FH34SRJ-13S-0.5SH(50)	—	13	8.5	6	7.03	7.88	7.6	8.4	7
FH34SRJ-14S-0.5SH(50)	—	14	9	6.5	7.53	8.38	8.1	8.9	7.5
FH34SRJ-15S-0.5SH(50)	—	15	9.5	7	8.07	8.88	8.6	9.4	8
FH34SRJ-16S-0.5SH(50)	—	16	10	7.5	8.57	9.38	9.1	9.9	8.5
FH34SRJ-17S-0.5SH(50)	—	17	10.5	8	9.07	9.88	9.6	10.4	9
FH34SRJ-18S-0.5SH(50)	—	18	11	8.5	9.57	10.38	10.1	10.9	9.5
FH34SRJ-20S-0.5SH(50)	—	20	12	9.5	10.57	11.38	11.1	11.9	10.5
FH34SRJ-21S-0.5SH(50)	—	21	12.5	10	11.07	11.88	11.6	12.4	11
FH34SRJ-22S-0.5SH(50)	—	22	13	10.5	11.57	12.38	12.1	12.9	11.5
FH34SRJ-23S-0.5SH(50)	—	23	13.5	11	12.07	12.88	12.6	13.4	12
FH34SRJ-24S-0.5SH(50)	—	24	14	11.5	12.57	13.38	13.1	13.9	12.5
FH34SRJ-26S-0.5SH(50)	—	26	15	12.5	13.57	14.38	14.1	14.9	13.5
FH34SRJ-27S-0.5SH(50)	—	27	15.5	13	14.07	14.88	14.6	15.4	14
FH34SRJ-28S-0.5SH(50)	—	28	16	13.5	14.57	15.38	15.1	15.9	14.5
FH34SRJ-30S-0.5SH(50)	—	30	17	14.5	15.57	16.38	16.1	16.9	15.5
FH34SRJ-32S-0.5SH(50)	—	32	18	15.5	16.53	17.38	17.1	17.9	16.5
FH34SRJ-34S-0.5SH(50)	—	34	19	16.5	17.53	18.38	18.1	18.9	17.5

*:Number of contact

※Contact positions without code numbers are currently under planning.
Contact HIROSE for detailed information about product variation.

[DIMENSION TABLE OF DRAWING FOR PACKING] △

PART No.	CODE No.	*	L	M	N	P	Q	R
FH34SRJ- 4S-0.5SH(50)	CL580-1238-7-50	4	16	7.5	—	4.3	17.4	21.4
FH34SRJ- 5S-0.5SH(50)	—	5	16	7.5	—	4.8	17.4	21.4
FH34SRJ- 6S-0.5SH(50)	CL580-1236-1-50	6	16	7.5	—	5.3	17.4	21.4
FH34SRJ- 7S-0.5SH(50)	—	7	16	7.5	—	5.8	17.4	21.4
FH34SRJ- 8S-0.5SH(50)	CL580-1231-8-50	8	16	7.5	—	6.3	17.4	21.4
FH34SRJ- 9S-0.5SH(50)	—	9	16	7.5	—	6.8	17.4	21.4
FH34SRJ-10S-0.5SH(50)	—	10	16	7.5	—	7.3	17.4	21.4
FH34SRJ-11S-0.5SH(50)	—	11	16	7.5	—	7.8	17.4	21.4
FH34SRJ-12S-0.5SH(50)	—	12	24	11.5	—	8.3	25.4	29.4
FH34SRJ-13S-0.5SH(50)	—	13	24	11.5	—	8.8	25.4	29.4
FH34SRJ-14S-0.5SH(50)	—	14	24	11.5	—	9.3	25.4	29.4
FH34SRJ-15S-0.5SH(50)	—	15	24	11.5	—	9.8	25.4	29.4
FH34SRJ-16S-0.5SH(50)	—	16	24	11.5	—	10.3	25.4	29.4
FH34SRJ-17S-0.5SH(50)	—	17	24	11.5	—	10.8	25.4	29.4
FH34SRJ-18S-0.5SH(50)	—	18	24	11.5	—	11.3	25.4	29.4
FH34SRJ-20S-0.5SH(50)	—	20	24	11.5	—	12.3	25.4	29.4
FH34SRJ-21S-0.5SH(50)	—	21	24	11.5	—	12.8	25.4	29.4
FH34SRJ-22S-0.5SH(50)	—	22	24	11.5	—	13.3	25.4	29.4
FH34SRJ-23S-0.5SH(50)	—	23	24	11.5	—	13.8	25.4	29.4
FH34SRJ-24S-0.5SH(50)	—	24	24	11.5	—	14.3	25.4	29.4
FH34SRJ-26S-0.5SH(50)	—	26	24	11.5	—	15.3	25.4	29.4
FH34SRJ-27S-0.5SH(50)	—	27	24	11.5	—	15.8	25.4	29.4
FH34SRJ-28S-0.5SH(50)	—	28	32	14.2	28.4	16.3	33.4	37.4
FH34SRJ-30S-0.5SH(50)	—	30	32	14.2	28.4	17.3	33.4	37.4
FH34SRJ-32S-0.5SH(50)	—	32	32	14.2	28.4	18.3	33.4	37.4
FH34SRJ-34S-0.5SH(50)	—	34	32	14.2	28.4	19.3	33.4	37.4

*:Number of contact

HRS	DRAWING NO.	EDC3-159714-01
	PART NO.	FH34SRJ-*S-0.5SH(50)
	CODE NO.	CL580

△ 3/5

DRAWING FOR REFERENCE: This is subject to change without notice
08/11/2012

This connector features small, thin and back flip design, requiring delicate and careful handling.
Read through the instructions shown below and handle the connector properly.

[Operation and Precautions]

1. Initial condition

Actuator does not have to be operated before inserting FPC, as the connector is delivered with the actuator opened.

[Caution]
-Do not operate the actuator before inserting FPC.
Operating the actuator without FPC could make the contact deformation which could prevent FPC insertion.

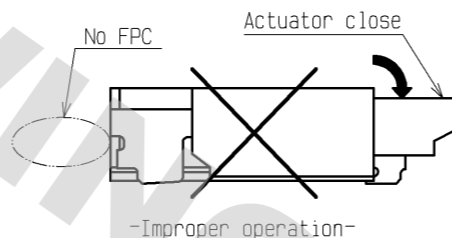
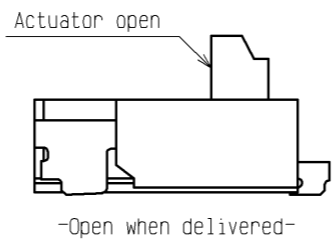

2. How to insert FPC

This connector has contacts on the bottom. Insert the FPC with the exposed conductors face down.

[Caution]
-Insert the FPC with the actuator opened.
-Do not insert the FPC with the conductor surface face up.
-Insert the FPC into the connector opening horizontally to the board plane.
-Insert it properly to the very end.
-Twisting the FPC to up and down, right and left or an angle could cause contact deformation and contact failure.

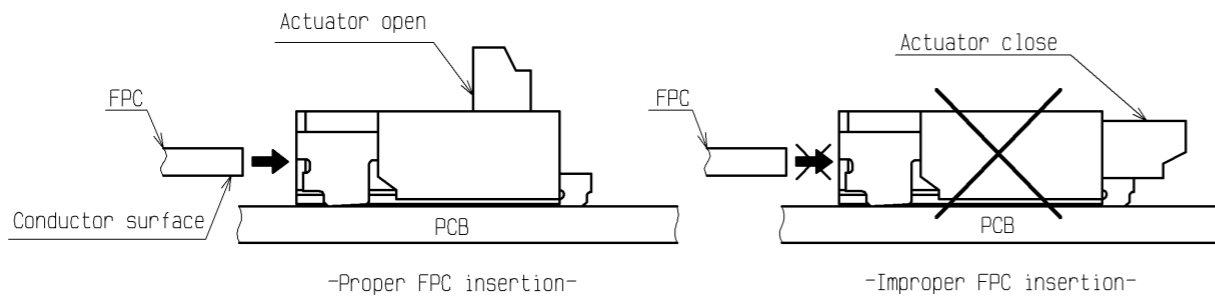

3. How to lock

Apply load to rotate the actuator by 90 degrees after inserting the FPC.

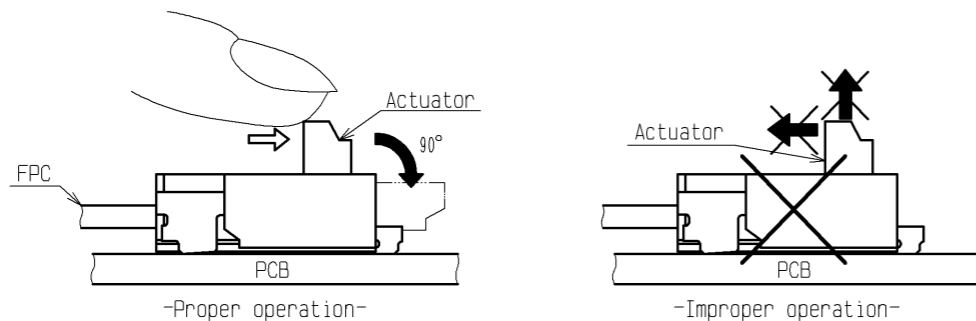

[Caution]

-The actuator rotates around the rotational axis as shown below.
-Do not rotate the actuator to the counter direction.
-Do not pinch or pick the actuator to lift. Otherwise, it may break.
-Apply load to the mid-point on the actuator to rotate it.
-Do not apply force to side end of the actuator.
-Uneven load could twist the actuator and cause half mating.
-Do not apply excess force to the housing during the operation.

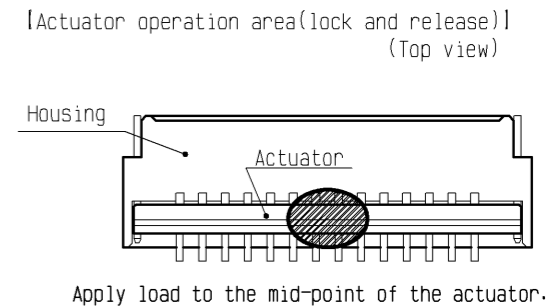
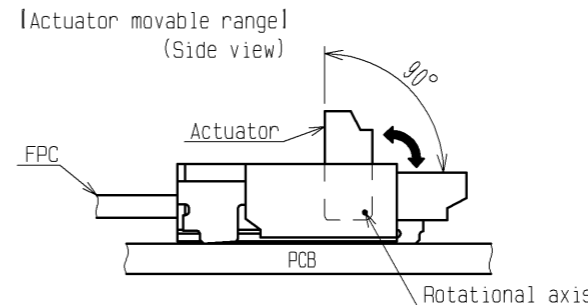

4. How to remove FPC (How to unlock)

Slowly apply load to rotate the actuator by 90 degrees to release the lock and remove the FPC.

[Caution]

-Do not press down the actuator toward connector when operating. Otherwise it could deform the contact.
-The actuator is opened up to the movable limit 90 degrees. Do not open the actuator beyond the specified degree or apply excess force to the actuator.
-Please operate at the mid-point when opening the actuator. Do not lift up only the side-end of the actuator, or it may twist the actuator and cause breakage.
-Please note that this connector is back flip style connector, which the opening area for FPC insertion and the actuator is on opposite side each other.
-Do not try to lift the actuator at the FPC insertion opening side, otherwise it may be breakage.

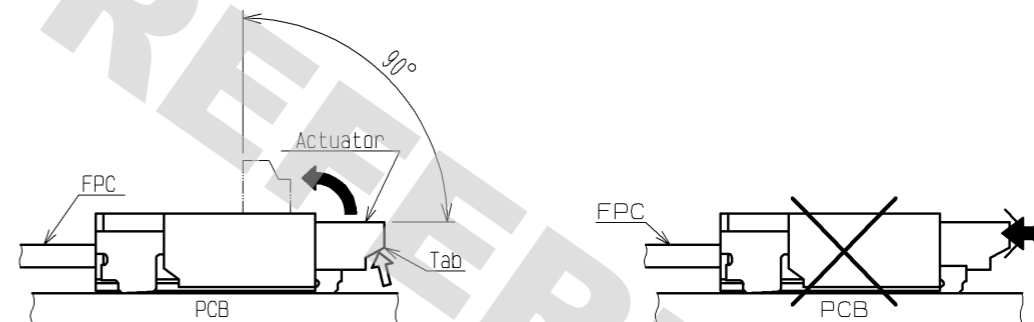

< INSTRUCTION MANUAL 1 >

HRS	DRAWING NO.	EDC3-159714-01
	PART NO.	FH34SRJ-*S-0.5SH(50)
	CODE NO.	CL580
		4/5

DRAWING FOR REFERENCE: This is subject to change without notice
08/11/2012

This connector features small, thin and back flip design, requiring delicate and careful handling. Read through the instructions shown below and handle the connector properly.

[Instruction for mounting on the board]

- ◆Warp of board
Minimize warp of the board as much as possible.
Lead co-planarity including reinforced metal fittings is 0.1mm or less.
Too much warp of the board may result in a soldering failure.
- ◆Load to connector
Do not apply mechanical stress to the connector before mounting on the board.
Otherwise, the connector may be broken.
Do not insert the FPC or operate the connector before mounting.
- ◆Load to board
-Splitting a large board into several pieces.
-Screwing the board
Avoid the handling described above so that no force is applied on the board during the assembly process.
Otherwise, the connector may become defective.
- ◆Reflow temperature profile
Apply reflow temperature profile within the specified conditions.
In individual applications, the actual temperature may vary,
depending on solder paste type, volume/thickness and board size/thickness.
Consult your solder paste and equipment manufacturer for specific recommendations.
- ◆Amount of bend of board
The bend of a 100-mm wide board should be 1mm or less as shown below.
The bend of board could apply stress on the connector and it may become defective.

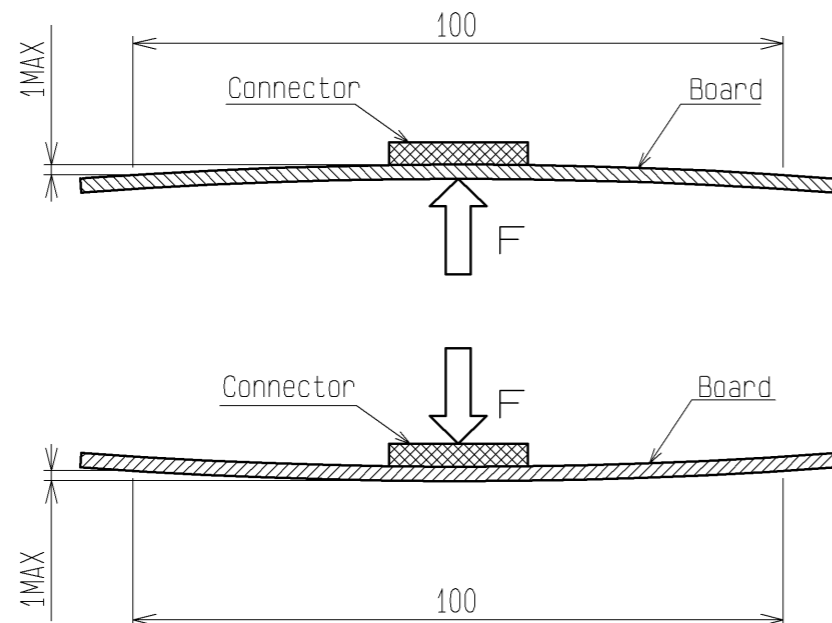

[Precautions for design]

1. During FPC wiring, ensure that stress is not applied directly to the connector.
Do not bend the FPC excessively near the connector during use, or it may cause contact failure or FPC breakage.
Stabilizing the FPC is recommended.
2. Keep a sufficient FPC insertion space in the stage of the layout in order to avoid incorrect FPC insertion.
Appropriate FPC length and component layout are recommended for assembly ease.
Too short FPC length makes assembly difficult.
3. Follow the recommended PCB layout, FPC design and the metal mask opening design.
4. Make adjustments with the FPC manufacturer for FPC bending performance and wire breakage.
5. Keep spaces for the actuator movement and its operation for PCB design and component layout.
6. If FPC is pulled to upward direction during withdrawal, upper arm of the contact may be deformed, and lead to contact fail.

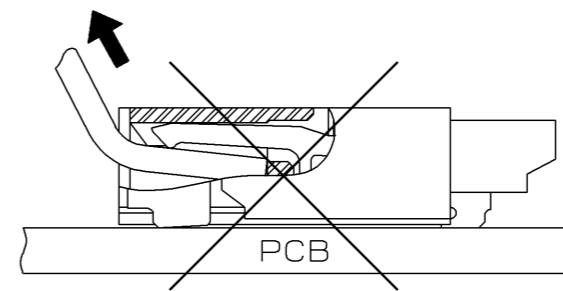

[Other instructions]

- ◆Instructions on manual soldering
Follow the instructions shown below when soldering the connector manually during repair work, etc.
 1. Do not perform manual soldering with the FPC inserted into the connector.
 2. Do not heat the connector excessively. Be very careful not to let the soldering iron contact any parts other than connector leads. Otherwise, the connector may be deformed or melt.
 3. Do not apply excessive solder (or flux).
If excessive solder (or flux) is applied on the terminals, solder or flux may adhere to the contacts or rotating parts of the actuator, resulting in poor contact or a rotation failure of the actuator.
Supplying excessive solder to the metal fittings may hinder actuator rotation, resulting in breakage of the connector.

<INSTRUCTION MANUAL 2>

HRS	DRAWING NO.	EDC3-159714-01
	PART NO.	FH34SRJ-*S-0.5SH(50)
	CODE NO.	CL580