

# 0.5 mm Pitch, 2 mm Height, FPC/FFC ZIF Connectors

## FH52 Series

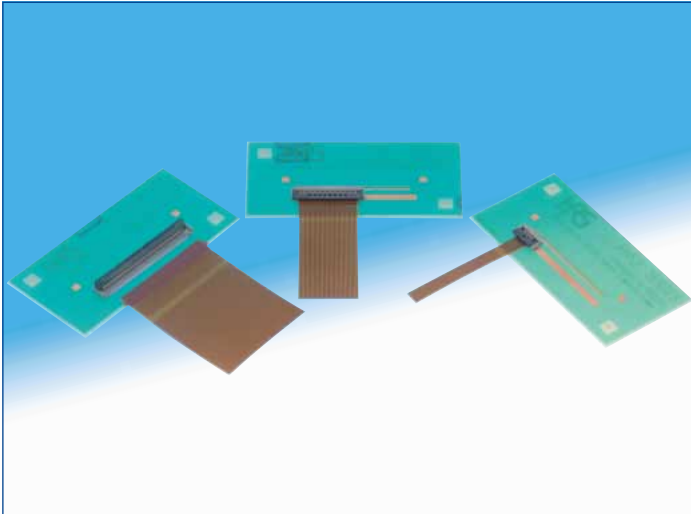

### Secure actuator retention

Metal fittings are designed to hold and stabilize the actuator

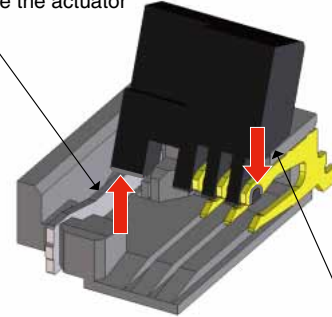

Contacts are designed to hold and stabilize the actuator

## ■ Features

### 1. Highly reliable connection and robust structure

With the need for higher contact counts and the need for a connector body that delivers unquestionable strength and a reliable connection in a FPC/FFC connector, the FH52 series has made great strides to meet this need. It meets this need with the following:

- An FPC positioning mechanism that delivers the high reliability requested
- A reliable and secure connection that is packed into a well-designed, durable structure.

### 2. Available with extended metal fittings

The FH52E Series has larger metal fittings that extend out from the connector body and enable a visual inspection of its soldering conditions.

### 3. Simplified operations

The flip lock structure makes it easier to engage/disengage the actuator and reduces the required force needed to operate. A clear tactile click is delivered upon the successful completion of the mating process.

### 4. Increased retention force

The side catch technology combined with tabbed FPCs increase the horizontal retention force of the FPC.

### 5. Accepts standard 0.3 mm thick FPC

It accepts 0.3 mm thick products that are easy to manufacture and have superb insertion performance.

### 6. Fully molded structure aids PCB layout

The bottom of this connector is enclosed by a fully molded structure that protects the contacts and removes any restrictions from PCB patterning and design.

### 7. Halogen-free

All materials and substances used to produce this product comply with Halogen-free standards.\* As defined in IEC 61249-2-21. Br: 900 ppm or less, Cl: 900 ppm or less, Br+Cl: 1,500 ppm or less

### 8. Supports automatic pick-n-place mounting

Offered in tape and reel packaging that is compatible with automatic machine mounting. (3,000 pieces per reel)

### 9. Multiple packing options

The standard packaging is 3,000 pieces per reel, but it is also offered in a 500 piece reel. (The outer diameter of the reel will be  $\phi$ 180 mm in this case.)

### Extended metal fitting option

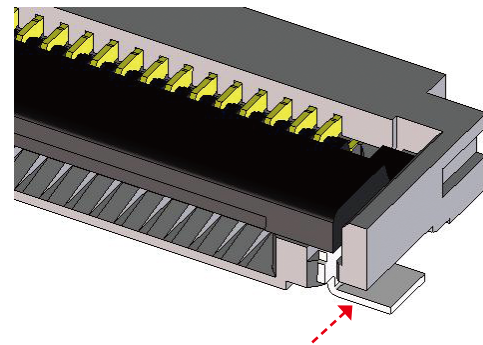

The metal fittings extend out from the connector body to enable a visual inspection of its soldering conditions.

Side catch technology designed to place a temporary hold on the FPC before the lock is engaged.

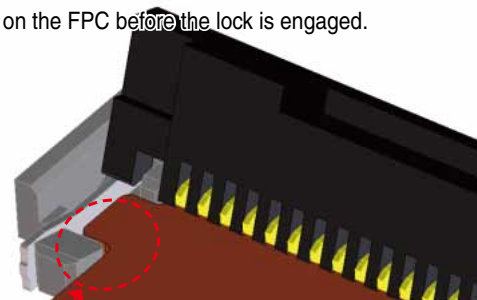

FPC with tab increase the retention force in horizontal direction.

FFC/EPC without tabs can also be used.

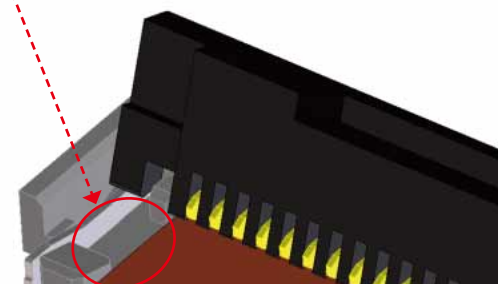

## Product Specifications

Rating	Rated current 0.5 A (Note 1) Rated voltage 50 VAC rms	Operating temperature range: -40°C to +85°C (Note 2) Operating humidity range: Relative humidity 90% max. (No condensation)	Storage temperature range: -10°C to +50°C (Note 3) Storage humidity range: Relative humidity 90% max. (No condensation)
Adaptive FPC/FFC contact specifications	Thickness: = 0.3 ± 0.05 mm Gold plated contact traces		
Item	Specification	Conditions	
1. Insulation resistance	500 MΩ min.	100 VDC	
2. Withstanding voltage	No flashover or insulation breakdown	150 VAC rms / 1 minute	
3. Contact resistance	50 mΩ max. * Including FPC/FFC conductor resistance	1 mA (DC or 1000 Hz)	
4. Durability (insertion / withdrawal)	Contact resistance: 50 mΩ max. No damage, cracks, or parts dislocation	20 cycles	
5. Vibration	No electrical discontinuity of 1 μs or more Contact resistance: 50 mΩ max. No damage, cracks, or parts dislocation	Frequency: 10 to 55 Hz, single amplitude of 0.75 mm, 10 cycles in each of the 3 directions	
6. Shock	No electrical discontinuity of 1 μs or more Contact resistance: 50 mΩ max. No damage, cracks, or parts dislocation	Acceleration of 981 m/s <sup>2</sup> , duration of 6 ms, sine half-wave waveform, 3 cycles in each of the 3 axes	
7. Humidity (Steady state)	Contact resistance: 50 mΩ max. Insulation resistance: 50 MΩ min. No damage, cracks, or parts dislocation	96 hours at temperature of 40°C and humidity of 90% to 95%	
8. Temperature cycle	Contact resistance: 50 mΩ max. Insulation resistance: 50 MΩ min. No damage, cracks, or parts dislocation	Temperature: -40°C → +15°C to +35°C → +85°C → +15°C to +35°C Time: 30 → 2 to 3 → 30 → 2 to 3 (Minutes) 5 cycles	
9. Resistance to soldering heat	No deformation of components affecting performance	Reflow: Peak temperature 250°C max., 230°C or more, 30 seconds or less Manual soldering: 350 ± 10°C for 5 seconds	

Note 1: When passing the current through all of the contacts, use 70% of the current rating.

Note 2: Includes temperature rise caused by current flow.

Note 3: The term “storage” refers to products stored for long period of time prior to mounting and use. Operating Temperature Range and Humidity Range covers non-conducting condition of installed connectors in storage, shipment or during transportation.

## Materials

Part	Material	Finish	Remarks
Insulator	LCP	Color: Grey	UL94V-0
		Color: Black	
Contacts	Phosphor bronze	Partially gold plated	_____
Metal fittings	Brass	Tine plated	

## Product Number Structure

Use the following information for identifying the product specifications from the product. Choose a product type described in this catalog when ordering.

**FH 52 E - 50S - 0.5 SH (99)**

①      ②      ③      ④      ⑤      ⑥      ⑦

① Series name: FH	⑤ Contact pitch: 0.5 mm
② Series No.: 52	⑥ Termination type SH: SMT horizontal mounting type
③ Blank: Standard type E: Long metal fittings type	⑦ SpecificationBlank: Partially gold plated, 3,000 pieces / reel (99): Partially gold plated, 500 pieces / reel
④ Number of contacts: 8 to 68	

# Connector Dimensions

## Standard Type

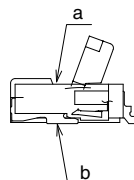
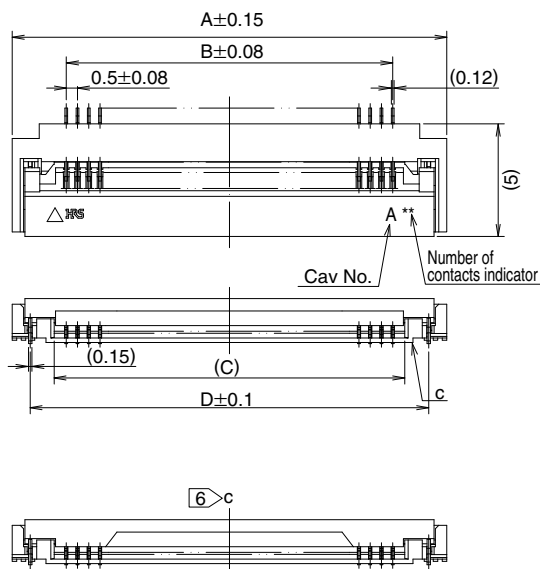

a detail drawing

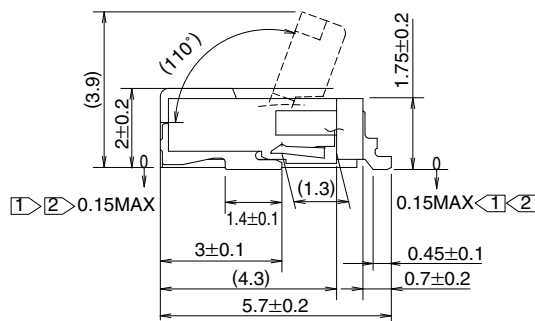

- Notes
- 1 The coplanarity of each terminal lead is within 0.1.
  - 2 The contact terminal lead position indicates the dimension from the b surface, the bottom surface of the insulator body.
  - 3 Packaged on tape and reel only. Check the packaging specification on Page 8 for details.
  - 4 Sink mark reliefs may be added due to improvements
  - 5 Sight variations in color of the plastic compounds do not affect form, fit or function.  
After reflow, the terminal plating may change color, however this does not represent a quality issue.
  - 6 The dimensions of 60-contact actuators are shown in the figures.

Unit: mm

Part number	HRS No.	Number of contacts	A	B	C	D
FH52-4S-0.5SH(**)	—	4	6.3	1.5	2.57	4.7
FH52-5S-0.5SH(**)	—	5	6.8	2.0	3.07	5.2
FH52-6S-0.5SH(**)	CL580-3304-0-**-	6	7.3	2.5	3.57	5.7
FH52-8S-0.5SH(**)	CL580-3305-3-**-	8	8.3	3.5	4.57	6.7
FH52-10S-0.5SH(**)	CL580-3306-6-**-	10	9.3	4.5	5.57	7.7
FH52-11S-0.5SH(**)	CL580-3320-7-**-	11	9.8	5.0	6.07	8.2
FH52-12S-0.5SH(**)	CL580-3307-9-**-	12	10.3	5.5	6.57	8.7
FH52-15S-0.5SH(**)	CL580-3302-5-**-	15	11.8	7.0	8.07	10.2
FH52-16S-0.5SH(**)	—	16	12.3	7.5	8.57	10.7
FH52-18S-0.5SH(**)	CL580-3321-0-**-	18	13.3	8.5	9.57	11.7
FH52-20S-0.5SH(**)	CL580-3309-4-**-	20	14.3	9.5	10.57	12.7
FH52-22S-0.5SH(**)	—	22	15.3	10.5	11.57	13.7
FH52-24S-0.5SH(**)	CL580-3318-5-**-	24	16.3	11.5	12.57	14.7
FH52-25S-0.5SH(**)	CL580-3316-0-**-	25	16.8	12.0	13.07	15.2
FH52-26S-0.5SH(**)	—	26	17.3	12.5	13.57	15.7
FH52-28S-0.5SH(**)	CL580-3324-8-**-	28	18.3	13.5	14.57	16.7
FH52-30S-0.5SH(**)	CL580-3310-3-**-	30	19.3	14.5	15.57	17.7
FH52-32S-0.5SH(**)	CL580-3325-0-**-	32	20.3	15.5	16.57	18.7
FH52-40S-0.5SH(**)	CL580-3300-0-**-	40	24.3	19.5	20.57	22.7
FH52-42S-0.5SH(**)	CL580-3329-1-**-	42	25.3	20.5	21.57	23.7
FH52-45S-0.5SH(**)	CL580-3311-6-**-	45	26.8	22.0	23.07	25.2
FH52-50S-0.5SH(**)	CL580-3303-8-**-	50	29.3	24.5	25.57	27.7
FH52-60S-0.5SH(**)	CL580-3301-2-**-	60	34.3	29.5	30.57	32.7

Note 1: Tape and reel packaging. (3,000 pieces / reel, 500 pieces / reel)

Order by number of reels.

## Connector Dimensions

### Long Metal Fittings Type

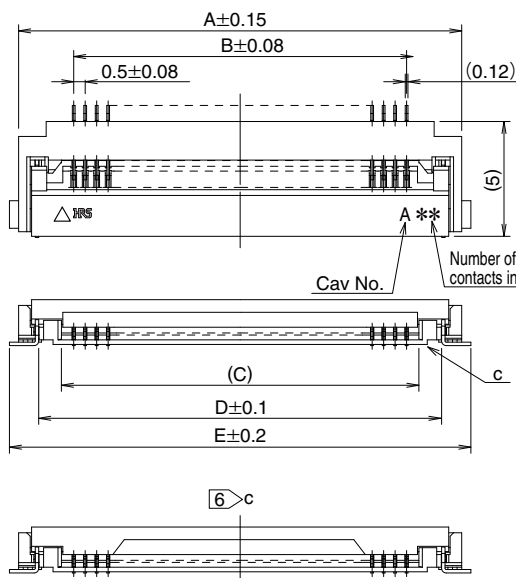

a detail drawing

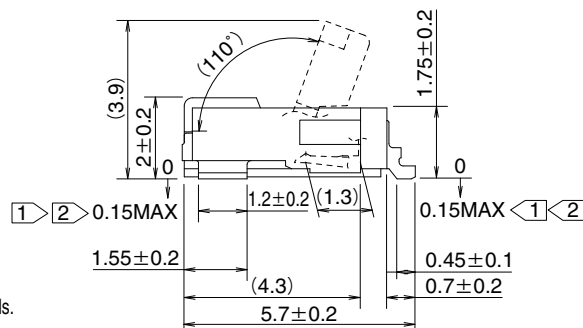

- Notes
- 1 The coplanarity of each terminal lead is within 0.1.
  - 2 The contact terminal lead position indicates the dimension from the b surface, the bottom surface of the insulator body.
  - 3 Packaged on tape and reel only. Check the packaging specification on Page 8 for details.
  - 4 Sink mark reliefs may be added due to improvements
  - 5 Sight variations in color of the plastic compounds do not affect form, fit or function.  
After reflow, the terminal plating may change color; however this does not represent a quality issue.
  - 6 The dimensions of 60-contact actuators are shown in the figures.

Unit: mm

Part number	HRS No.	Number of contacts	A	B	C	D	E
FH52E-4S-0.5SH(**)	————	4	6.3	1.5	2.57	4.55	7.1
FH52E-5S-0.5SH(**)	————	5	6.8	2.0	3.07	5.05	7.6
FH52E-6S-0.5SH(**)	————	6	7.3	2.5	3.57	5.55	8.1
FH52E-8S-0.5SH(**)	————	8	8.3	3.5	4.57	6.55	9.1
FH52E-10S-0.5SH(**)	————	10	9.3	4.5	5.57	7.55	10.1
FH52E-11S-0.5SH(**)	————	11	9.8	5.0	6.07	8.05	10.6
FH52E-12S-0.5SH(**)	————	12	10.3	5.5	6.57	8.55	11.1
FH52E-15S-0.5SH(**)	CL580-3337-0-***	15	11.8	7.0	8.07	10.05	12.6
FH52E-16S-0.5SH(**)	————	16	12.3	7.5	8.57	10.55	13.1
FH52E-18S-0.5SH(**)	CL580-3331-3-***	18	13.3	8.5	9.57	11.55	14.1
FH52E-20S-0.5SH(**)	————	20	14.3	9.5	10.57	12.55	15.1
FH52E-22S-0.5SH(**)	————	22	15.3	10.5	11.57	13.55	16.1
FH52E-24S-0.5SH(**)	————	24	16.3	11.5	12.57	14.55	17.1
FH52E-25S-0.5SH(**)	————	25	16.8	12.0	13.07	15.05	17.6
FH52E-26S-0.5SH(**)	————	26	17.3	12.5	13.57	15.55	18.1
FH52E-28S-0.5SH(**)	————	28	18.3	13.5	14.57	16.55	19.1
FH52E-30S-0.5SH(**)	————	30	19.3	14.5	15.57	17.55	20.1
FH52E-32S-0.5SH(**)	————	32	20.3	15.5	16.57	18.55	21.1
FH52E-40S-0.5SH(**)	CL580-3334-1-***	40	24.3	19.5	20.57	22.55	25.1
FH52E-42S-0.5SH(**)	————	42	25.3	20.5	21.57	23.55	26.1
FH52E-45S-0.5SH(**)	————	45	26.8	22.0	23.07	25.05	27.6
FH52E-50S-0.5SH(**)	CL580-3335-4-***	50	29.3	24.5	25.57	27.55	30.1
FH52E-60S-0.5SH(**)	CL580-3339-5-***	60	34.3	29.5	30.57	32.55	35.1
FH52E-64S-0.5SH(**)	CL580-3333-9-***	64	36.3	31.5	32.57	34.55	37.1
FH52E-68S-0.5SH(**)	CL580-3332-6-***	68	38.3	33.5	34.57	36.55	39.1

Note 1: Tape and reel packaging. (3,000 pieces / reel, 500 pieces / reel)  
Order by number of reels.

## Recommended PCB Mounting Pattern and Metal Mask Dimensions

### Standard Type

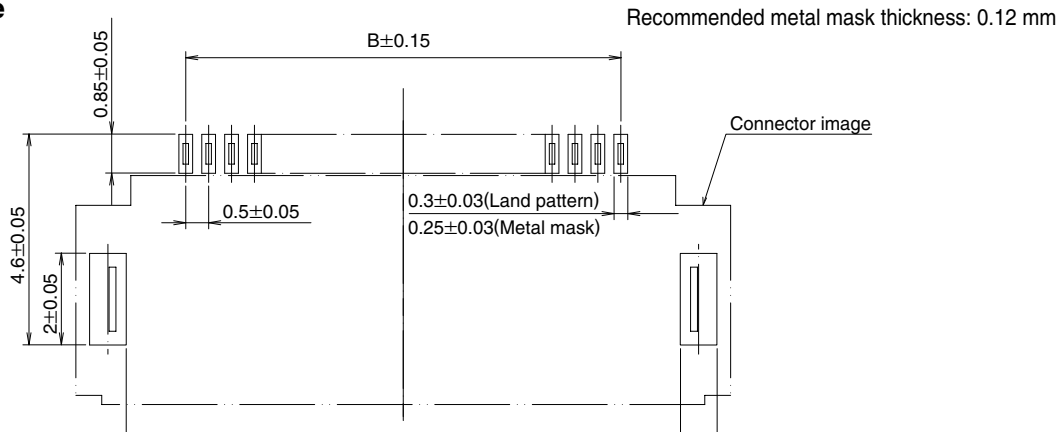

\* The recommended PCB mounting pattern for the FH12 Series (horizontal mounting type) can be used as well.

## Recommended FPC/FFC Dimensions

### Standard Type

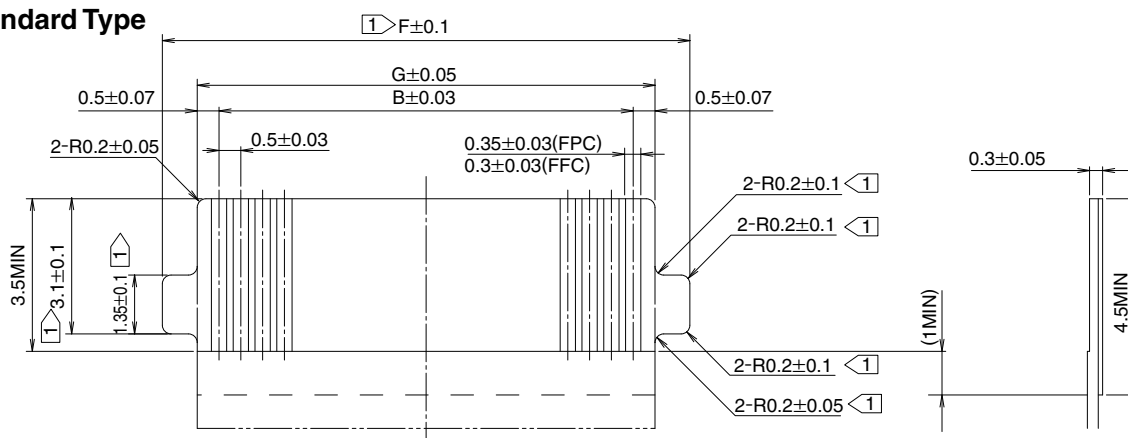

Notes ① FFC/FPC without tabs can also be used.  
In that case, the specified portions are not necessary.

Unit: mm

Part number	HRS No.	Number of contacts	B	E	F	G
FH52-4S-0.5SH(**)	—	4	1.5	4.1	4.1	2.5
FH52-5S-0.5SH(**)	—	5	2.0	4.6	4.6	3.0
FH52-6S-0.5SH(**)	CL580-3304-0-**-	6	2.5	5.1	5.1	3.5
FH52-8S-0.5SH(**)	CL580-3305-3-**-	8	3.5	6.1	6.1	4.5
FH52-10S-0.5SH(**)	CL580-3306-6-**-	10	4.5	7.1	7.1	5.5
FH52-11S-0.5SH(**)	CL580-3320-7-**-	11	5.0	7.6	7.6	6.0
FH52-12S-0.5SH(**)	CL580-3307-9-**-	12	5.5	8.1	8.1	6.5
FH52-15S-0.5SH(**)	CL580-3302-5-**-	15	7.0	9.6	9.6	8.0
FH52-16S-0.5SH(**)	—	16	7.5	10.1	10.1	8.5
FH52-18S-0.5SH(**)	CL580-3321-0-**-	18	8.5	11.1	11.1	9.5
FH52-20S-0.5SH(**)	CL580-3309-4-**-	20	9.5	12.1	12.1	10.5
FH52-22S-0.5SH(**)	—	22	10.5	13.1	13.1	11.5
FH52-24S-0.5SH(**)	CL580-3318-5-**-	24	11.5	14.1	14.1	12.5
FH52-25S-0.5SH(**)	CL580-3316-0-**-	25	12.0	14.6	14.6	13.0
FH52-26S-0.5SH(**)	—	26	12.5	15.1	15.1	13.5
FH52-28S-0.5SH(**)	CL580-3324-8-**-	28	13.5	16.1	16.1	14.5
FH52-30S-0.5SH(**)	CL580-3310-3-**-	30	14.5	17.1	17.1	15.5
FH52-32S-0.5SH(**)	CL580-3325-0-**-	32	15.5	18.1	18.1	16.5
FH52-40S-0.5SH(**)	CL580-3300-0-**-	40	19.5	22.1	22.1	20.5
FH52-42S-0.5SH(**)	CL580-3329-1-**-	42	20.5	23.1	23.1	21.5
FH52-45S-0.5SH(**)	CL580-3311-6-**-	45	22.0	24.6	24.6	23.0
FH52-50S-0.5SH(**)	CL580-3303-8-**-	50	24.5	27.1	27.1	25.5
FH52-60S-0.5SH(**)	CL580-3301-2-**-	60	29.5	32.1	32.1	30.5

## Recommended PCB Mounting Pattern and Metal Mask Dimensions

### Long Metal Fittings Type

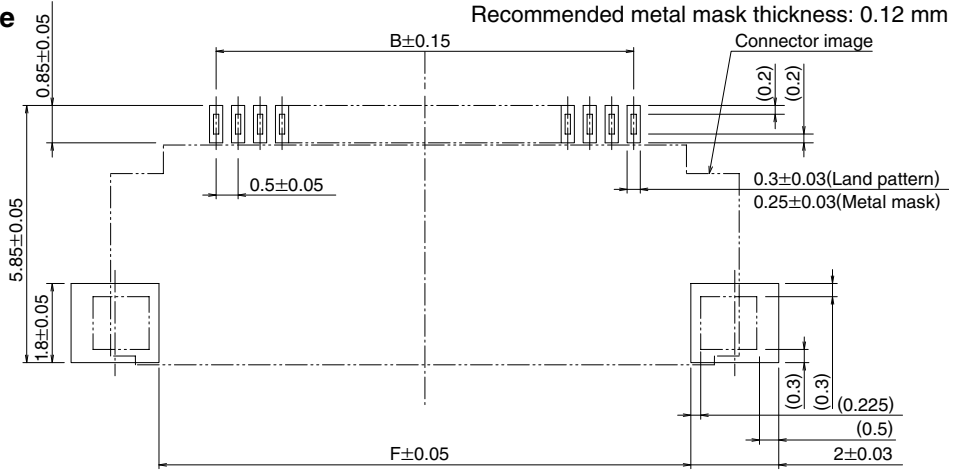

## Recommended FPC/FFC Dimensions

### Long Metal Fittings Type

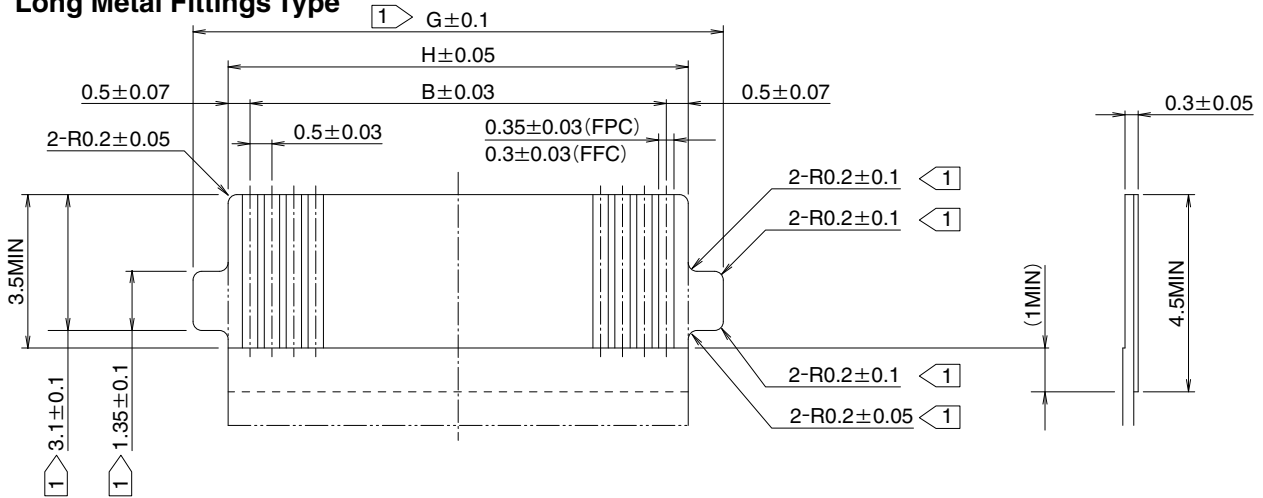

Notes ① FFC/FPC without tabs can also be used.  
In that case, the specified portions are not necessary.

Unit: mm

Part number	HRS No.	Number of contacts	B	F	G	H
FH52E-4S-0.5SH(**)	—	4	1.5	4.1	4.1	2.5
FH52E-5S-0.5SH(**)	—	5	2.0	4.6	4.6	3.0
FH52E-6S-0.5SH(**)	—	6	2.5	5.1	5.1	3.5
FH52E-8S-0.5SH(**)	—	8	3.5	6.1	6.1	4.5
FH52E-10S-0.5SH(**)	—	10	4.5	7.1	7.1	5.5
FH52E-11S-0.5SH(**)	—	11	5.0	7.6	7.6	6.0
FH52E-12S-0.5SH(**)	—	12	5.5	8.1	8.1	6.5
FH52E-15S-0.5SH(**)	CL580-3337-0-***	15	7.0	9.6	9.6	8.0
FH52E-16S-0.5SH(**)	—	16	7.5	10.1	10.1	8.5
FH52E-18S-0.5SH(**)	CL580-3331-3-***	18	8.5	11.1	11.1	9.5
FH52E-20S-0.5SH(**)	—	20	9.5	12.1	12.1	10.5
FH52E-22S-0.5SH(**)	—	22	10.5	13.1	13.1	11.5
FH52E-24S-0.5SH(**)	—	24	11.5	14.1	14.1	12.5
FH52E-25S-0.5SH(**)	—	25	12.0	14.6	14.6	13.0
FH52E-26S-0.5SH(**)	—	26	12.5	15.1	15.1	13.5
FH52E-28S-0.5SH(**)	—	28	13.5	16.1	16.1	14.5
FH52E-30S-0.5SH(**)	—	30	14.5	17.1	17.1	15.5
FH52E-32S-0.5SH(**)	—	32	15.5	18.1	18.1	16.5
FH52E-40S-0.5SH(**)	CL580-3334-1-***	40	19.5	22.1	22.1	20.5
FH52E-42S-0.5SH(**)	—	42	20.5	23.1	23.1	21.5
FH52E-45S-0.5SH(**)	—	45	22.0	24.6	24.6	23.0
FH52E-50S-0.5SH(**)	CL580-3335-4-***	50	24.5	27.1	27.1	25.5
FH52E-60S-0.5SH(**)	CL580-3339-5-***	60	29.5	32.1	32.1	30.5
FH52E-64S-0.5SH(**)	CL580-3333-9-***	64	31.5	34.1	34.1	32.5
FH52E-68S-0.5SH(**)	CL580-3332-6-***	68	33.5	36.1	36.1	34.5

## FH52 Series FPC/FFC Construction (Recommended Specifications)

### 1. Using Single-Sided FPC

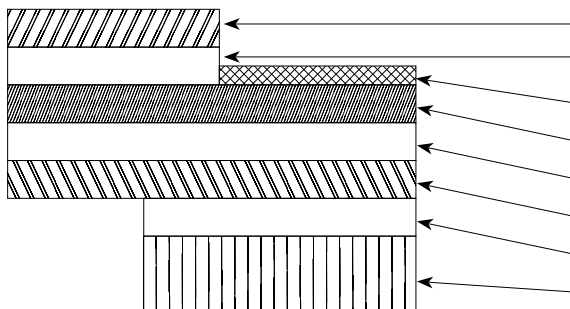

### FPC : Flexible Printed Circuit

Material name	Material	Thickness (μm)
Covering film layer	Polyimide 1mil	(25)
Cover adhesive		(25)
Surface treatment	0.2 μm thick gold plated over 1 to 5 μm thick nickel underplating	3
Copper foil	Cu 1oz	35
Base adhesive	Thermosetting adhesive	25
Base film	Polyimide 1mil thick	25
Reinforcement material adhesive	Thermosetting adhesive	30
Stiffener	Polyimide 7mil thick	175
Total		293

### 2. Using Double-Sided FPC

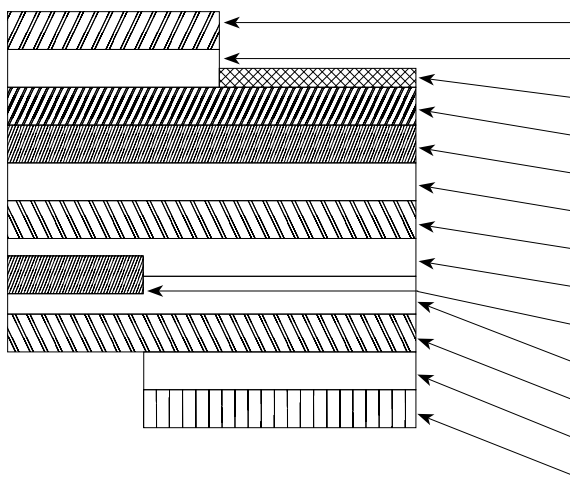

### FPC : Flexible Printed Circuit

Material name	Material	Thickness (μm)
Covering film layer	Polyimide 1mil	(25)
Cover adhesive		(25)
Surface treatment	0.2 μm thick gold plated over 1 to 5 μm thick nickel underplating	3
Through-hole copper	Cu	15
Copper foil	Cu 1/2oz	18
Base adhesive	Thermosetting adhesive	18
Base film	Polyimide 1mil thick	25
Base adhesive	Thermosetting adhesive	18
Copper foil	Cu 1/2oz	(18)
Cover adhesive	Thermosetting adhesive	25
Covering layer film	Polyimide 1mil thick	25
Reinforcement material adhesive	Thermosetting adhesive	50
Stiffener	Polyimide 4mil thick	100
Total		297

\* To prevent release of the FPC due to its bending, use of the double sided FPC with copper foil on the back side is not recommended.

### 3. Using FFC

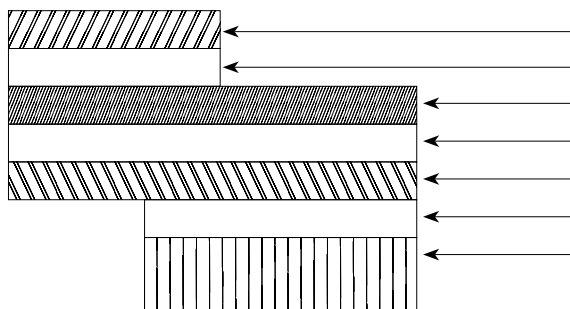

### FFC : Flexible Flat Cable

Material name	Material	Thickness (μm)
Polyester film		(12)
Adhesive	Thermoplastic polyester	(30)
Gold plated annealed copper foil		35
Adhesive	Polyester	30
Polyester		12
Adhesive	Polyester	30
Stiffener	Polyester	188
Total		295

\* Typical thickness tolerance is about ±20 μm

1. This specification is a recommendation for the construction of the FH52 Series FPC and FFC (t = 0.3 ± 0.05 mm).
2. For details about the construction, please contact the FPC/FFC manufacturers.

## ■ Packaging Specification

### ● Embossed carrier tape dimensions (tape width 24 mm or less)

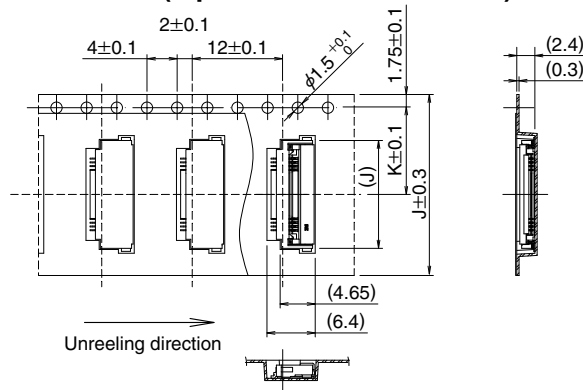

### ● Embossed carrier tape dimensions (tape width 32 mm or more)

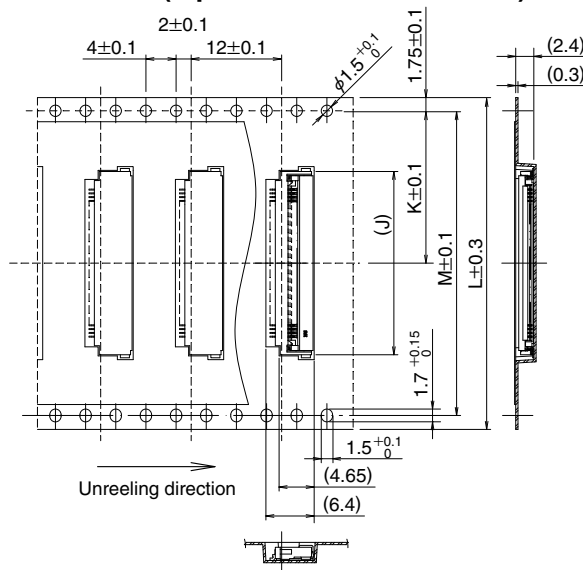

### ● Reel Dimensions

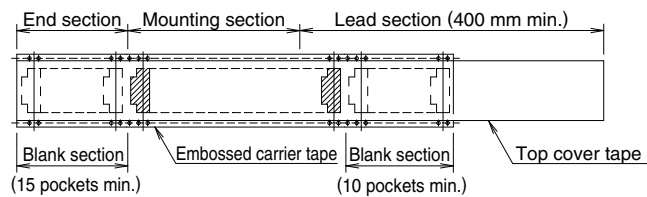
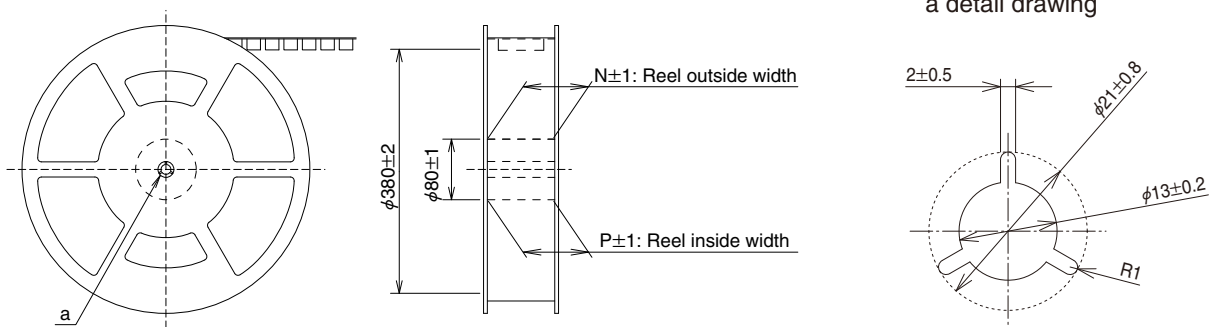



## Standard Type

Unit: mm



Part number	HRS No.	Number of contacts	J	K	L	M	N	P
FH52-4S-0.5SH(**)	—————	4	6.6	7.5	16.0	—————	21.4	17.4
FH52-5S-0.5SH(**)	—————	5	7.1	11.5	24.0	—————	29.4	25.4
FH52-6S-0.5SH(**)	CL580-3304-0-***	6	7.6	11.5	24.0	—————	29.4	25.4
FH52-8S-0.5SH(**)	CL580-3305-3-***	8	8.6	11.5	24.0	—————	29.4	25.4
FH52-10S-0.5SH(**)	CL580-3306-6-***	10	9.6	11.5	24.0	—————	29.4	25.4
FH52-11S-0.5SH(**)	CL580-3320-7-***	11	10.1	11.5	24.0	—————	29.4	25.4
FH52-12S-0.5SH(**)	CL580-3307-9-***	12	10.6	11.5	24.0	—————	29.4	25.4
FH52-15S-0.5SH(**)	CL580-3302-5-***	15	12.1	11.5	24.0	—————	29.4	25.4
FH52-16S-0.5SH(**)	—————	16	12.6	11.5	24.0	—————	29.4	25.4
FH52-18S-0.5SH(**)	CL580-3321-0-***	18	13.6	11.5	24.0	—————	29.4	25.4
FH52-20S-0.5SH(**)	CL580-3309-4-***	20	14.6	11.5	24.0	—————	29.4	25.4
FH52-22S-0.5SH(**)	—————	22	15.6	14.2	32.0	28.4	37.4	33.4
FH52-24S-0.5SH(**)	CL580-3318-5-***	24	16.6	14.2	32.0	28.4	37.4	33.4
FH52-25S-0.5SH(**)	CL580-3316-0-***	25	17.1	14.2	32.0	28.4	37.4	33.4
FH52-26S-0.5SH(**)	—————	26	17.6	14.2	32.0	28.4	37.4	33.4
FH52-28S-0.5SH(**)	CL580-3324-8-***	28	18.6	14.2	32.0	28.4	37.4	33.4
FH52-30S-0.5SH(**)	CL580-3310-3-***	30	19.6	14.2	32.0	28.4	37.4	33.4
FH52-32S-0.5SH(**)	CL580-3325-0-***	32	20.6	20.2	44.0	40.4	49.4	45.4
FH52-40S-0.5SH(**)	CL580-3300-0-***	40	24.6	20.2	44.0	40.4	49.4	45.4
FH52-42S-0.5SH(**)	CL580-3329-1-***	42	25.6	20.2	44.0	40.4	49.4	45.4
FH52-45S-0.5SH(**)	CL580-3311-6-***	45	27.1	20.2	44.0	40.4	49.4	45.4
FH52-50S-0.5SH(**)	CL580-3303-8-***	50	29.6	20.2	44.0	40.4	49.4	45.4
FH52-60S-0.5SH(**)	CL580-3301-2-***	60	34.6	26.2	56.0	52.4	61.4	57.4

## Long Metal Fittings Type

Unit: mm

Part number	HRS No.	Number of contacts	J	K	L	M	N	P
FH52E-4S-0.5SH(**)	—————	4	6.6	7.5	16.0	—————	21.4	17.4
FH52E-5S-0.5SH(**)	—————	5	7.1	11.5	24.0	—————	29.4	25.4
FH52E-6S-0.5SH(**)	—————	6	7.6	11.5	24.0	—————	29.4	25.4
FH52E-8S-0.5SH(**)	—————	8	8.6	11.5	24.0	—————	29.4	25.4
FH52E-10S-0.5SH(**)	—————	10	9.6	11.5	24.0	—————	29.4	25.4
FH52E-11S-0.5SH(**)	—————	11	10.1	11.5	24.0	—————	29.4	25.4
FH52E-12S-0.5SH(**)	—————	12	10.6	11.5	24.0	—————	29.4	25.4
FH52E-15S-0.5SH(**)	CL580-3337-0-***	15	12.1	11.5	24.0	—————	29.4	25.4
FH52E-16S-0.5SH(**)	—————	16	12.6	11.5	24.0	—————	29.4	25.4
FH52E-18S-0.5SH(**)	CL580-3331-3-***	18	13.6	11.5	24.0	—————	29.4	25.4
FH52E-20S-0.5SH(**)	—————	20	14.6	11.5	24.0	—————	29.4	25.4
FH52E-22S-0.5SH(**)	—————	22	15.6	14.2	32.0	28.4	37.4	33.4
FH52E-24S-0.5SH(**)	—————	24	16.6	14.2	32.0	28.4	37.4	33.4
FH52E-25S-0.5SH(**)	—————	25	17.1	14.2	32.0	28.4	37.4	33.4
FH52E-26S-0.5SH(**)	—————	26	17.6	14.2	32.0	28.4	37.4	33.4
FH52E-28S-0.5SH(**)	—————	28	18.6	14.2	32.0	28.4	37.4	33.4
FH52E-30S-0.5SH(**)	—————	30	19.6	20.2	44.0	40.4	49.4	45.4
FH52E-32S-0.5SH(**)	—————	32	20.6	20.2	44.0	40.4	49.4	45.4
FH52E-40S-0.5SH(**)	CL580-3334-1-***	40	24.6	20.2	44.0	40.4	49.4	45.4
FH52E-42S-0.5SH(**)	—————	42	25.6	20.2	44.0	40.4	49.4	45.4
FH52E-45S-0.5SH(**)	—————	45	27.1	20.2	44.0	40.4	49.4	45.4
FH52E-50S-0.5SH(**)	CL580-3335-4-***	50	29.6	20.2	44.0	40.4	49.4	45.4
FH52E-60S-0.5SH(**)	CL580-3339-5-***	60	34.6	26.2	56.0	52.4	61.4	57.4
FH52E-64S-0.5SH(**)	CL580-3333-9-***	64	36.6	26.2	56.0	52.4	61.4	57.4
FH52E-68S-0.5SH(**)	CL580-3332-6-***	68	38.6	26.2	56.0	52.4	61.4	57.4

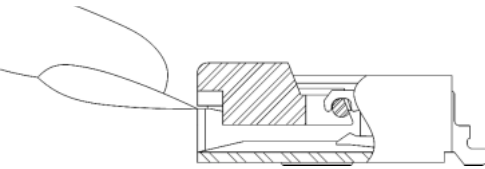
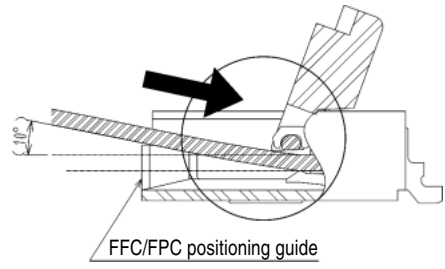
## Operation and Precautions

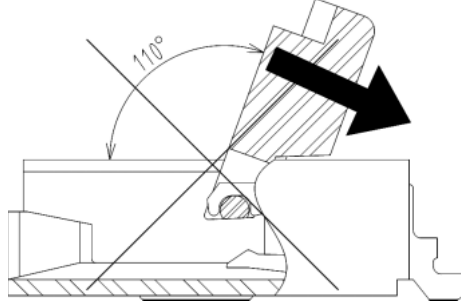
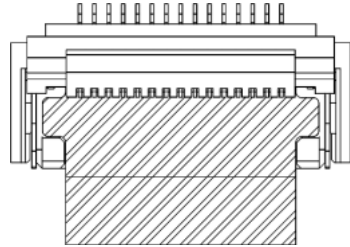
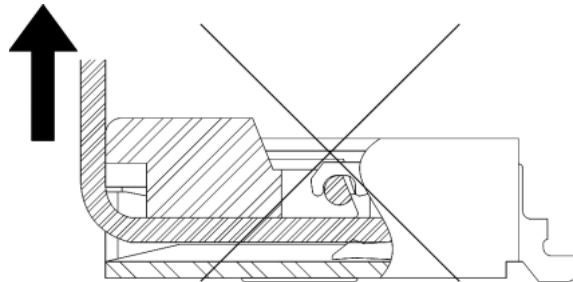
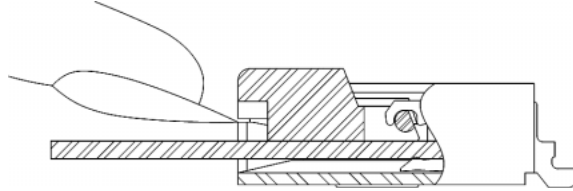
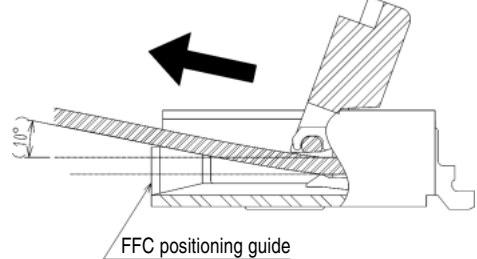
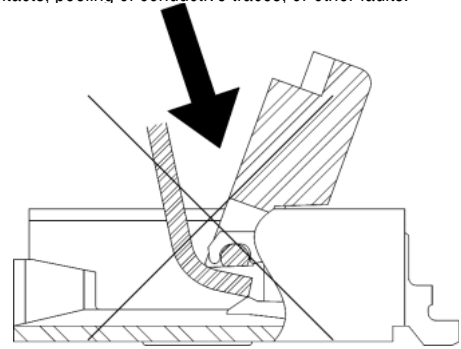
Operation	Precautions
<p><b>1. FPC/FFC insertion procedure</b></p> <p>① Lift up the actuator to release the lock. You can easily pop it up with the thumbnail or index-finger nail.</p>  <p>② Insert the FPC or FFC with the exposed conductive traces facing down. When connecting a tabbed FPC or FFC, securely insert it to the bottom, perpendicular to the connector with an angle of 10° with respect to the PCB surface, using the FFC/FPC positioning guide.</p>  <p>③ Rotate down the actuator until firmly closed.</p> 	<p>① The FH52 Series is equipped with an actuator that rotates approximately 110°. Do not apply a force to open it beyond its fully open position. The actuator may come off or be permanently damaged.</p>  <p>② Insert the FPC or FFC properly to the opening of the connector. Improper insertion may lead to a break or poor continuity of the FPC or FFC.</p>  <p>③ The connector does not have a strong upward tensile strength owing to its structure. Secure the FPC or FFC when it is subjected to a tensile force.</p> 
<p><b>2. FPC/FFC removal</b></p> <p>① Lift up the actuator to release the lock. Pull up the FPC or FFC a little and then withdraw it from the connector.</p>   <p>FFC positioning guide</p>	<p>④ When inserting an FPC or FFC, do not rub it vigorously against the bottom side of the connector opening. Excessive contact between the contacts and the FPC or FFC may result in the deformation of contacts, peeling of conductive traces, or other faults.</p> 

## ■Precautions (Mating/Un-Mating FPC/FFC with the Retention Tabs)

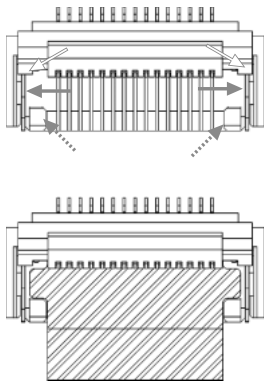
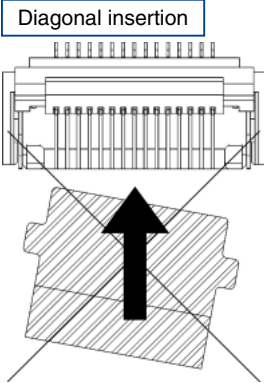
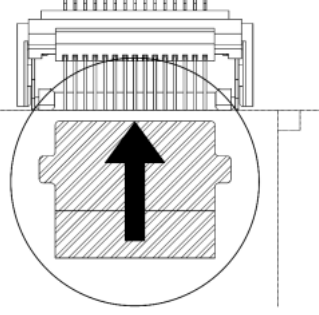
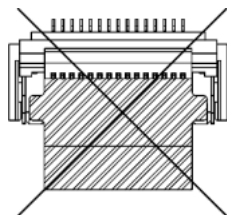
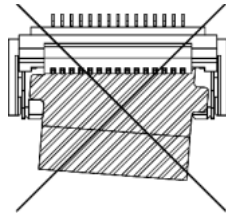
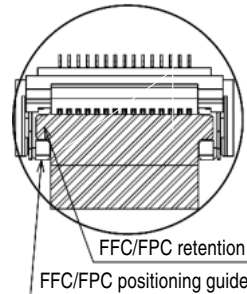
Operation	Precautions
<p><b>1. How to insert</b></p> <p>Insert the cable into the interspace (.....) between the mold walls (→) at both ends of entrance where the connector is inserted and the guide walls (→) at both ends of interior connector so the cable tabs are properly located.</p>  <p><b>2. Precautions when mating/un-mating</b></p> <p><b>① Avoid insertion in diagonal direction.</b></p> <p>Do not insert the cable in diagonal direction. A part of the connector may touches the contacts resulting in deformation of the contacts.</p> <p><b>Diagonal insertion</b></p>  <p>Be sure to insert the FPC or FFC straight into the connector opening until the bottom of the connector.</p> <p><b>Perpendicular to the connector</b></p> 	<p><b>② Avoid "ride on"</b></p> <p>Avoid insertion so the cables ride on any guide. Be sure NOT to close the actuator as the cables ride on any guide. It may cause conduction failure.</p> <p><b>Ride on the both guides</b></p>  <p><b>Ride on the right guide</b></p>  <p><b>Correct insertion</b></p> 

## ■Recommended Temperature Profile

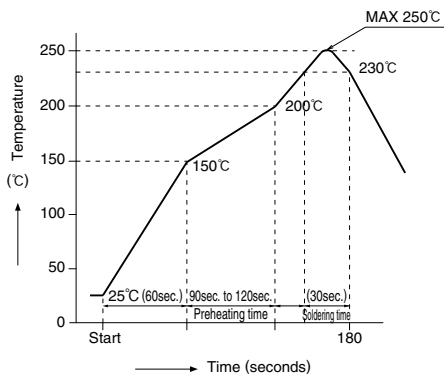

### HRS test condition

Solder method	: Reflow, IR
Reflow furnace atmosphere	: Atmosphere
Solder composition	: Paste, 96.5%Sn/3.0%Ag/0.5%Cu (Senju Metal Industry's Part Number: M705-221CM5-32-10.5)
Test board	: Material and size
Glass epoxy	: 80 mm x 100 mm x 1.6 mm thick
Land dimensions	: 0.3 x 0.85 mm
Metal mask dimensions	: 0.12 mm thick
Opening dimensions	: 0.25 x 0.85 mm

The temperature profiles are based on the above conditions.

In individual applications the actual temperature may vary, depending on solder paste type, volume/thickness and board size/thickness. Consult your solder paste and equipment manufacturer for specific recommendations.

**USA:**

**HIROSE ELECTRIC (U.S.A.), INC. Headquarters**  
 2688 Westhills Court, Simi Valley, CA 93065-6235  
 Phone : 1-805-522-7958  
 Fax : 1-805-522-3217  
<http://www.hiroseusa.com>

**USA:**

**HIROSE ELECTRIC (U.S.A.), INC. North California Office**  
 20400 Stevens Creek Blvd., Ste 250, Cupertino, CA 95014  
 Phone : 1-408-253-9640  
 Fax : 1-408-253-9641  
<http://www.hiroseusa.com>

**USA:**

**HIROSE ELECTRIC (U.S.A.), INC. Detroit Office (Automotive)**  
 37677 Professional Center Drive, Suite #100C  
 Livonia, MI 48154  
 Phone : 1-734-542-9963  
 Fax : 1-734-542-9964  
<http://www.hiroseusa.com>

**GERMANY:**

**HIROSE ELECTRIC EUROPE B.V. GERMAN BRANCH**  
 Herzog-Carl-Strasse 4 D-73760 Ostfildern  
 (Scharnhäuser Park)  
 Phone : 49-711-4560-02-1  
 Fax : 49-711-4560-02-299  
<http://www.hirose.de>

**THE NETHERLANDS:**

**HIROSE ELECTRIC EUROPE B.V.**  
 Hogehillweg #8 1101 CC Amsterdam Z-0  
 Phone : 31-20-6557460  
 Fax : 31-20-6557469  
<http://www.hiroseeurope.com>

**UK:**

**HIROSE ELECTRIC EUROPE B.V. UK BRANCH**  
 First Floor, St Andrews House, Caldecotte Lake  
 Business Park, Milton Keynes MK7 8LE  
 Phone : 44-1908-369060  
 Fax : 44-1908-369078  
<http://www.hirose.co.uk>

**CHINA:**

**HIROSE ELECTRIC CO., LTD. BEIJING REPRESENTATIVE OFFICE**  
 A1001, Ocean International Center, Building 56# East 4th  
 Ring Middle Road, Chao Yang District, Beijing, 100025  
 Phone : 86-10-5165-9332  
 Fax : 86-10-5908-1381  
<http://www.hirose-china.com.cn>

**CHINA:**

**HIROSE ELECTRIC (SHANGHAI) CO., LTD.**  
 1501-02, Cross Tower Building, 318 Fuzhou Road,  
 Huang Pu District, Shanghai 200001  
 Phone : 86-21-6391-3355  
 Fax : 86-21-6335-0767  
<http://www.hirose-china.com.cn>

**CHINA:**

**HIROSE ELECTRIC CO., LTD. SHENZHEN OFFICE**  
 Room 09-13, 19/F, Office Tower Shun Hing Square, Di Wang Commercial Centre  
 5002, ShenNanDong Road, ShenZhen City, Guangdong Province, 518008  
 Phone : 86-755-8207-0851  
 Fax : 86-755-8207-0873  
<http://www.hirose-china.com.cn>

**HONG KONG:**

**HIROSE ELECTRIC HONGKONG TRADING CO., LTD.**  
 Unit 1102 A&B, Energy Plaza, 92 Granville Road,  
 Tsim Sha Tsui East, Kowloon  
 Phone : 852-2803-5338  
 Fax : 852-2591-6560  
<http://www.hirose-hongkong.com.hk>

**TAIWAN:**

**HIROSE ELECTRIC TAIWAN CO., LTD.**  
 103 8F, No.87, Zhengzhou Rd., Taipei  
 Phone : 886-2-2555-7377  
 Fax : 886-2-2555-7350  
<http://www.hirose-taiwan.com.tw>

**SINGAPORE:**

**HIROSE ELECTRIC CO., LTD.**  
 10 Anson Road #26-16 International Plaza 079903  
 Phone : 65-6324-6113  
 Fax : 65-6324-6123  
<http://www.hirose-singapore.com.sg>

**KOREA:**

**HIROSE KOREA CO., LTD.**  
 1261-10, Jeoungwhang-Dong, Shihung-City,  
 Kyunggi-Do 429-450  
 Phone : 82-31-496-7000,7124  
 Fax : 82-31-496-7100  
<http://www.hirose.co.kr>



**HIROSE ELECTRIC CO.,LTD.**

6-3,Nakagawa Chuoh-2-Chome,Tsuzuki-Ku,Yokohama-Shi 224-8540,JAPAN  
 TEL: +81-45-620-3526 Fax: +81-45-591-3726  
<http://www.hirose.com>  
<http://www.hirose-connectors.com>