

NEW

4 Amp Micro Hybrid Board to FPC Connectors

BM22 Series

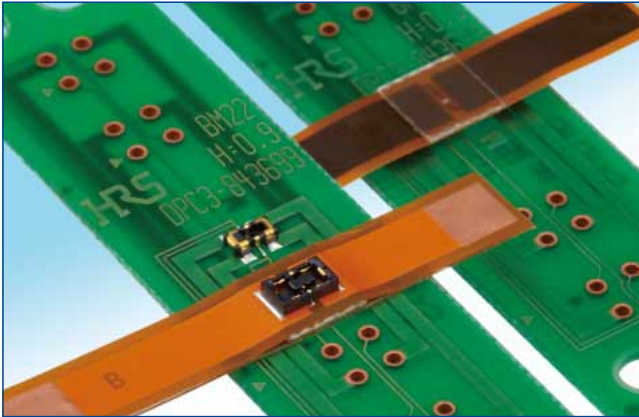

63% Reduction in footprint (Compared to the dimensions of Hirose's B-to-W DF57)

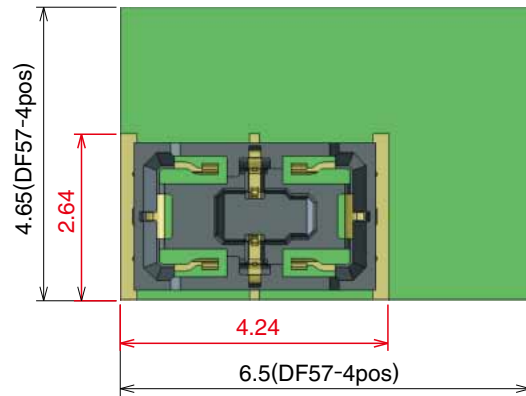

Features

1. 4 Amp current rating

The space-saving design utilizes two power contacts that can carry up to 4 Amps of current, and two signal contacts that can also carry 0.3 Amps of current. This is all delivered in a small connector that features a small mounting depth of 2.64 mm.

2. Two point contact structure

The structure utilizes two points on each contact to ensure a secure connection for both types of contacts (power and signal).

3. Good Mating Operability

The connector contributes to the enhanced mating operability by giving a clicking feeling which is effective in preventing incomplete mating, and mating self-alignment of 0.3 mm which is secured by the guide ribs.

Application

Devices that need to be slim and compact such as cell phones and tablet PCs.

Vacuum area

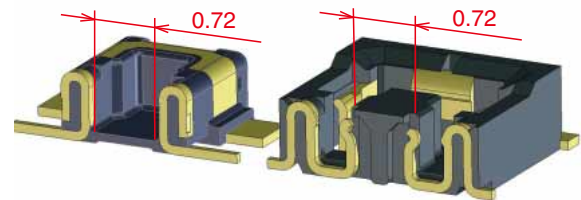

Mating Cross-Section Diagram

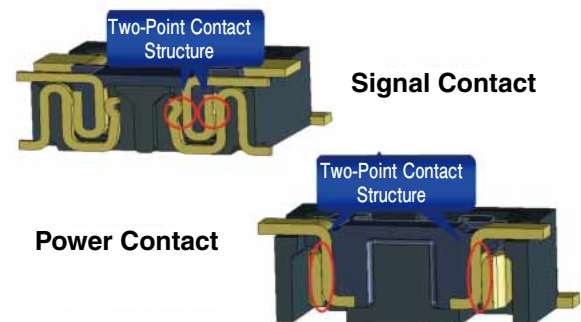

Specifications

Ratings	Current rating	Power contact: 4 Amps/pin Signal contact: 0.3 Amps/pin	Operating temperature range	-35 to 85°C (Note 1)	Storage temperature range	-10 to 60°C (Note 2)
	Voltage rating	30 V AC/DC	Operating humidity range	20 to 80%	Storage humidity range	40 to 70% (Note 2)

Item	Specification	Conditions
1. Insulation resistance	Minimum of 50 MΩ	Measured at 100 V DC
2. Withstanding voltage	No flashover or insulation breakdown	Conduct 100 V AC for 1 minute
3. Contact resistance	Signal contact: Maximum of 50 mΩ Power contact: Maximum of 30 mΩ	Measured at 20 mV AC, 1 kHz, 1 mA
4. Vibration	No electrical discontinuity of 1 μs or longer	Frequency: 10 to 55 Hz, single amplitude of 0.75 mm, 3 directions, 2 hours
5. Humidity	Contact resistance: Maximum of 100 mΩ Insulation resistance: Minimum of 25 MΩ	96 hours at a temperature of 40 ±2°C and a humidity range from 90 to 95%
6. Temperature cycle	Contact resistance: Maximum of 100 mΩ Insulation resistance: Minimum of 50 MΩ	(-55°C: 30 minutes → 5 to 35°C: 10 minutes → 85°C: 30 minutes → 5 to 35°C: 10 minutes), 5 cycles
7. Durability	Contact resistance: Maximum of 100 mΩ	10 mating cycles
8. Solder Heat Resistance	No signs of melting or deformity on the molded resin parts and no negative effects on performance.	Reflow: according to the Recommended Solder Profile Hand soldering: Soldering iron temperature 350°C, no more than 3 seconds of contact

Note 1: Includes temperature rise caused by current flow.

Note 2: The term "storage" here refers to products stored for a long period prior to board mounting and use. The operating temperature and humidity range covers the non-energized condition of connectors after board mounting and the temporary storage conditions during transportation, etc.

Note 3: The specifications shown above represent general requirements for this series. Contact us for the drawings and specifications for a specific part number shown

Material

Product	Part	Material	Finish	UL standard
Receptacle / Header	Insulator	LCP	Black	UL94V-0
	Contacts	Copper alloy	Gold plated	—

Composition of Product Number

Refer to this page when determining product specifications by model types. Please place orders with part numbers listed in this catalog. The characteristics and specifications of the product described in this catalog are reference values. Please make sure to check the latest delivery specifications at the time of product use.

● Receptacles / Headers

BM 22 - * S - V (51)

① ② ③ ④ ⑤ ⑥

① Series name: BM	⑤ Termination type V: Straight SMT
② Series No.: 22	⑥ Gold plated specification and packaging status (51): Gold plate thickness 0.05 μm Embossed tape packaging (10,000 pieces per reel) (78): Gold plate thickness 0.30 μm Embossed tape packaging (10,000 pieces per reel)
③ Number of contacts: 4 (2 for signal and 2 for power) 6 (4 for signal and 2 for power)	
④ Connector type: S: Receptacle P: Header	

Receptacles

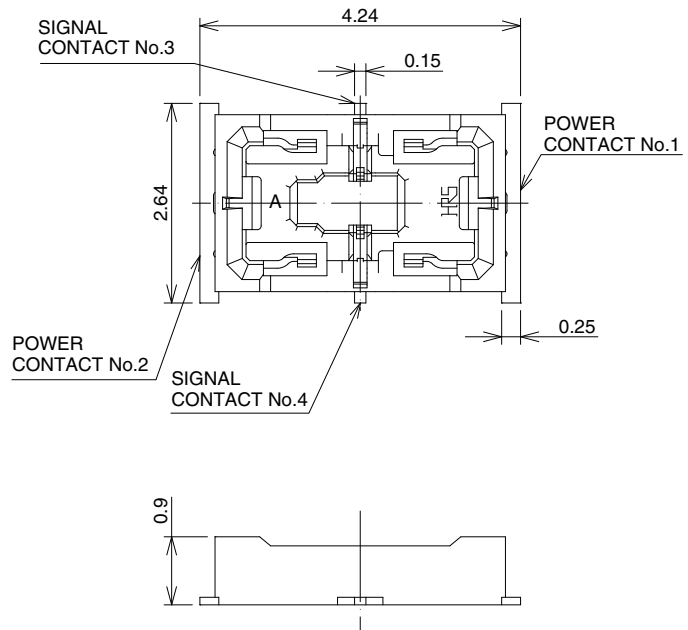

Recommended PCB layout (4 contacts)

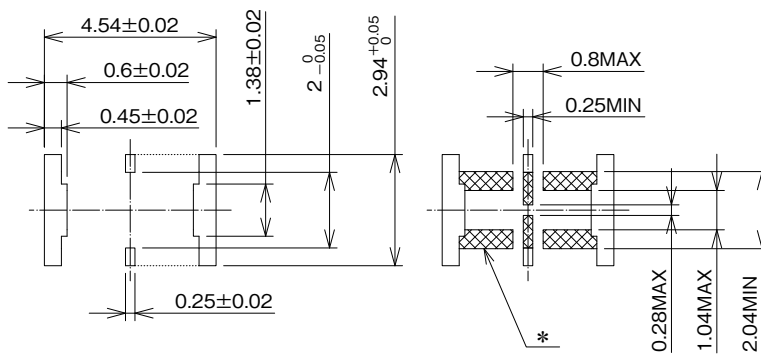

*: PCB layout prohibited area

(Do not use different circuit patterns; however the same circuit that is connected to the footprint can be routed over the prohibited area, but soldering resist must be applied over the trace.)

Recommended metal mask dimensions (mask thickness: 100 μm) (4 contacts)

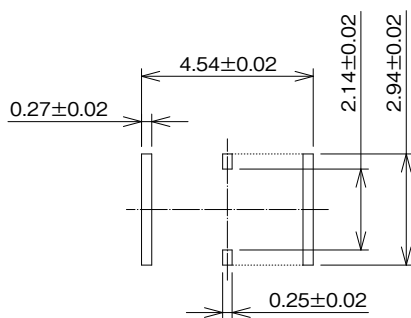

Part No.	HRS No.	Number of Contacts
BM22-4S-V (51)	CL0677-1002-6-51	4
BM22-6S-V (51)	CL0677-1004-1-51	6

(Note) This product is packaged on reels; please place your orders for full reel quantities.

■Headers

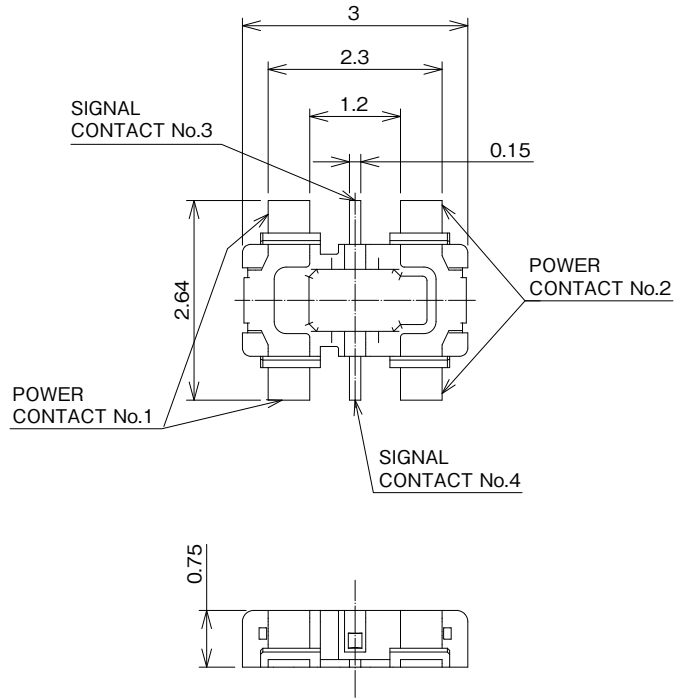

■Recommended PCB layout (4 contacts)

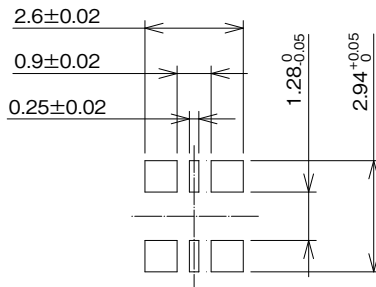

■Recommended metal mask dimensions (mask thickness: 100 μm) (4 contacts)

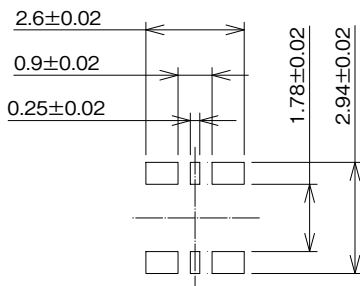

Product Number	HRS No.	Number of Contacts
BM22-4P-V (51)	CL0677-1001-3-51	4
BM22-6P-V (51)	CL0677-1003-9-51	6

(Note) This product is packaged on reels; please place your orders for full reel quantities.

■ Embossed Tape Dimensions (complies with JIS C 0806)

● Receptacle

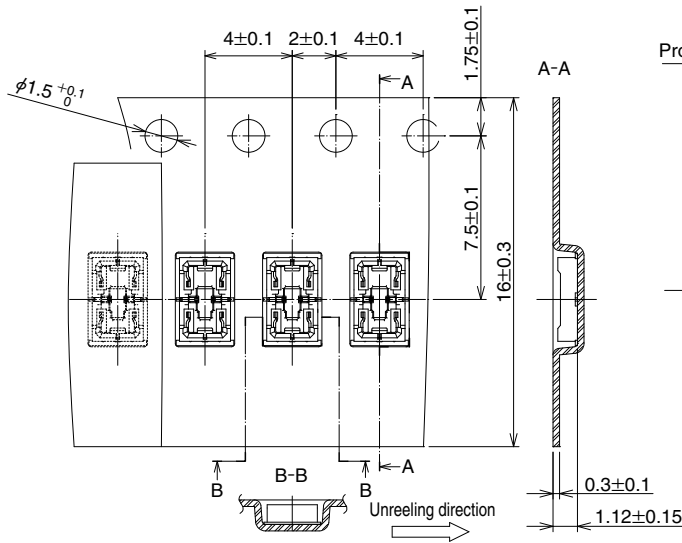

● Reel dimensions

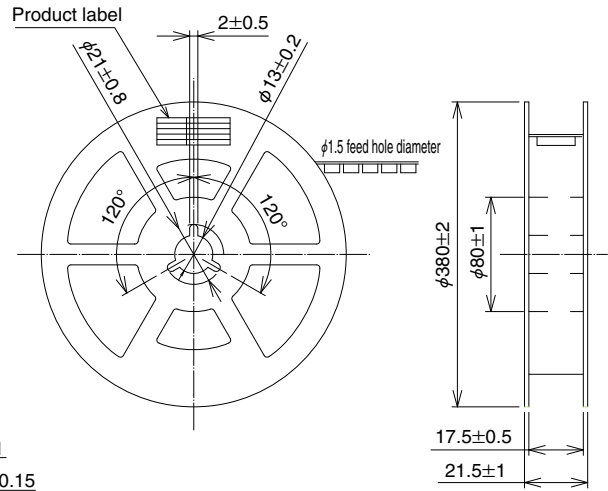

● Header

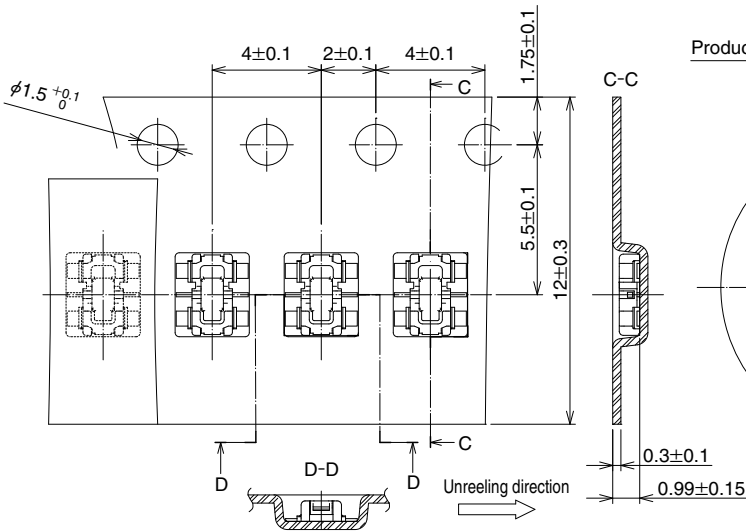

● Reel dimensions

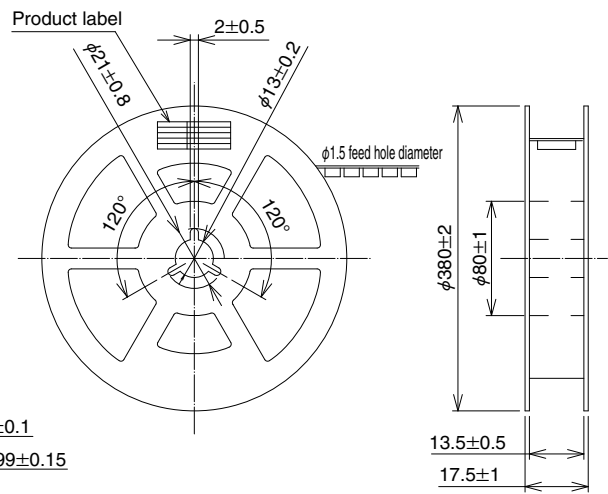

Usage Recommendations

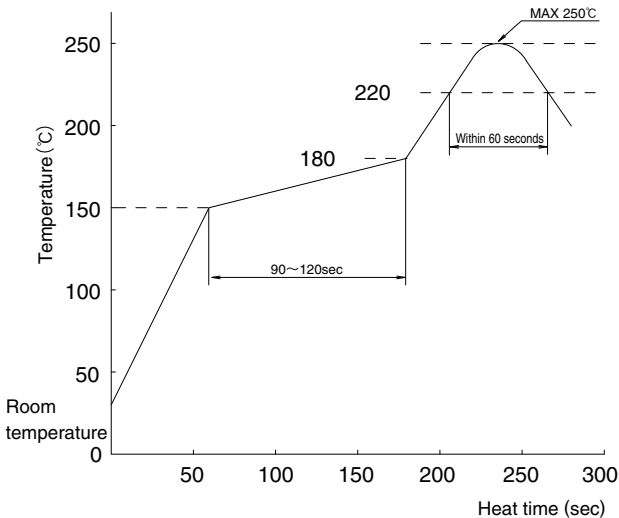

<p>1. Recommended Soldering Profile</p>	 <p>[Condition]</p> <ol style="list-style-type: none"> 1. Peak temperature : Maximum of 250°C 2. Heat section : 220°C min., within 60 seconds 3. Preheat section : 150 to 180°C, 90 to 120 seconds 4. Number of reflow cycles : Maximum of 2 cycles <p>Note 1: The temperature represents the PCB surface temperature in the vicinity of the connector lead section. Note 2: For the use of Nitrogen reflow, mount the connectors with an oxygen density of 1,000 ppm or higher. Consult Hirose for the condition less than 1,000 ppm.</p>
<p>2. Recommended manual soldering condition</p>	<p>Soldering iron temperature: 340 ±10°C, soldering time: within 3 seconds</p>
<p>3. Recommended stencil thickness and open area ratio to PCB pattern area</p>	<p>Thickness: 0.1 mm Open area ratio: 85% for signal contact, and 60% for power contact on the Receptacle side. 70% for both contacts on the Plug side</p>
<p>4. Board warpage</p>	<p>Maximum of 0.02 mm in the center of the connector, while using both ends of the connector as reference point</p>
<p>5. Cleaning conditions</p>	<p>We do not recommend cleaning these connectors. Cleaning them may alter the mating/un-mating operations. If you do clean them, make sure you test that these operations have not been compromised prior to use.</p>
<p>6. Precautions</p>	<ul style="list-style-type: none"> ● Do not mate or un-mate these connectors until they are mounted, failure to follow this precaution can lead to deformation or damage to these connectors. ● Provide another form of support to the PCB, this connector was not designed to be the main form of support. ● When mating/un-mating this connector, do not apply excessive twisting forces onto the connector. These forces can damage the contacts and alter its performance. ● Do not apply excessive amounts of flux as it may cause the flux to wick. ● There may be a slight variance in the color of the molding between production lots; this variance will not affect the performance of the connector. ● Refer to the next page for the handling precautions when mating and un-mating these connectors. ● If the connector becomes disconnected due to impact, a fall or a counterforce to the FPC, it may be necessary to hold the connector in place with an addition to the device's case or other cushioning material to hold the connector in place.

Feb.1.2016 Copyright 2016 HIROSE ELECTRIC CO., LTD. All Rights Reserved.

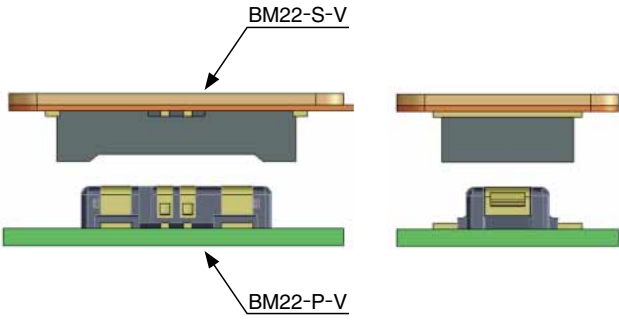
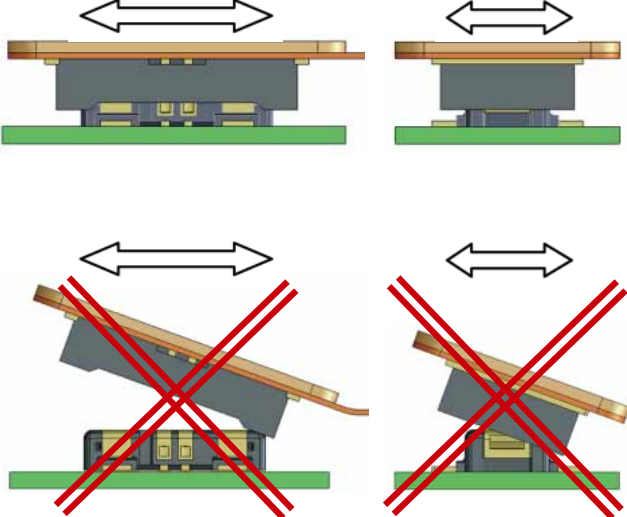
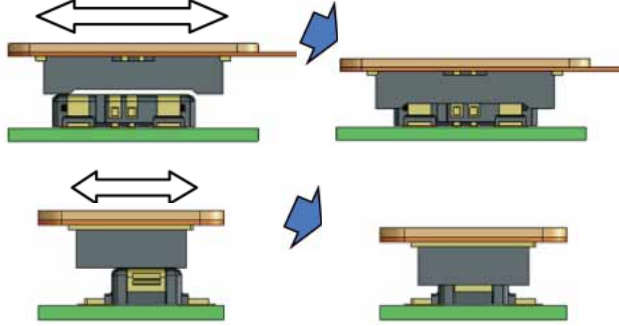
■ Handling Precautions when Mating Connectors

	
	<p>Prior to mating, locate the guidance ribs and align the header. Do not apply excessive force during the mating process as it may damage the contacts.</p>
	<p>When the connector has been correctly aligned, the header will be parallel to the receptacle. An even force can now be applied to the header to mate it with the receptacle until it is fully mated.</p>

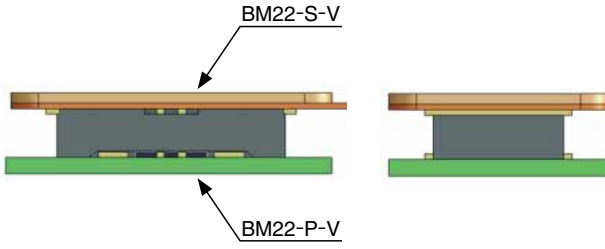
■ Handling Precautions when Un-mating Connectors

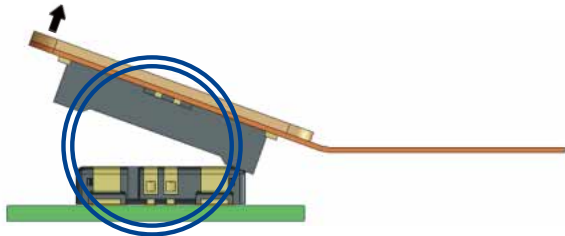
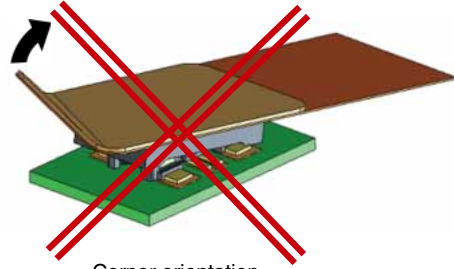
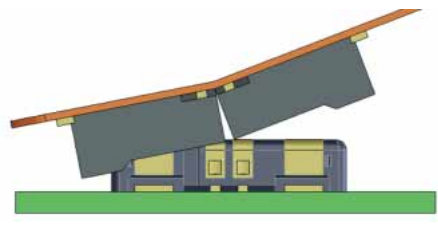
 <p>BM22-S-V</p> <p>BM22-P-V</p>	
	<p>To un-mate this connector, lift evenly across the header. Make sure that each side of the connector stays parallel to the other.</p>
 <p>Pitch orientation</p>	<p>If circumstances prevent the connectors from staying parallel to each other, then one side may be lifted as shown in the diagram. This method is only approved if the connector is mounted onto an extremely rigid circuit board. If the board were to warp during this process it may result in damage to the connector or its solder joints.</p>
 <p>Corner orientation</p>	<p>Do not try to disconnect these connectors by pulling on one side or a single corner, or to un-mate it when it is hasn't been securely mounted onto a rigid FPC. These actions may lead to deformities and ultimately a damaged connector. Prior to the mounting of these connectors we recommend that you check the rigidity of your FPC to ensure that it meets the standards needed to support these connectors.</p>
	<p>If the FPC is not strong enough by itself, a stiffener may be applied. If the FPC has a low rigidity the connector may break (as shown in the illustration to the left). We recommend a backing of no less than 0.3 mm of glass epoxy and 0.2 mm of stainless material.</p>



HIROSE ELECTRIC CO.,LTD.

6-3,Nakagawa Chuoh-2-Chome,Tsuzuki-Ku,Yokohama-Shi 224-8540,JAPAN
 TEL: +81-45-620-3526 Fax: +81-45-591-3726
<http://www.hirose.com>
<http://www.hirose-connectors.com>