

**4-Pin μ P Voltage Monitors with Manual Reset Input****Features**

- Precision Monitoring of +3V, +3.3V, and +5V Power-Supply Voltages
- Fully Specified Over Temperature
- Available in Three Output Configurations
 - Push-Pull $\overline{\text{RESET}}$ Output (G692L)
 - Push-Pull RESET Output (G692H)
 - Open-Drain $\overline{\text{RESET}}$ Output (G693L)
- 140ms Min Power-On Reset Pulse Width
- 14 μ A Supply Current
- Guaranteed Reset Valid to $V_{CC} = +1V$
- Power Supply Transient Immunity
- No External Components
- Manual Reset Input
- 4-Pin SOT-143 and 5-Pin SC-70 Package
- 2% Threshold Accuracy

Applications

- Computers
- Controllers
- Intelligent Instruments
- Critical μ P and μ C Power Monitoring
- Portable / Battery-Powered Equipment
- Automotive

General Description

The G692/G693 are microprocessor (μ P) supervisory circuits used to monitor the power supplies in μ P and digital systems. They provide excellent circuit reliability and low cost by eliminating external components and adjustments when used with +5V, +3.3V, +3.0V- powered circuits. The G692/G693 also provide a de-bounced manual reset input.

These circuits perform a single function: they assert a reset signal whenever the V_{CC} supply voltage declines below a preset threshold, keeping it asserted for at least 140ms after V_{CC} has risen above the reset threshold. Reset thresholds suitable for operation with a variety of supply voltages are available.

The G693L has an open-drain output stage, while the G692 have push-pull outputs. The G693L's open-drain $\overline{\text{RESET}}$ output requires a pull-up resistor that can be connected to a voltage higher than V_{CC} .

The G692L have an active-low $\overline{\text{RESET}}$ output, while the G692H has an active-high RESET output. The reset comparator is designed to ignore fast transients on V_{CC} , and the outputs are guaranteed to be in the correct logic state for V_{CC} down to 1V.

Low supply current makes the G692/G693 ideal for use in portable equipment. The G692/G693 are available in a 4-pin SOT-143 and 5-Pin SC-70 packages.

Ordering Information

ORDER NUMBER	ORDER NUMBER (Pb free)	TEMP. RANGE	PACKAGE
G692HxxxTCU	G692HxxxTCUf	-40°C~+105°C	SOT-143
G692LxxxTCU	G692LxxxTCUf	-40°C~+105°C	SOT-143
G693LxxxTCU	G693LxxxTCUf	-40°C~+105°C	SOT-143
G692HxxxTAU	G692HxxxTAUf	-40°C~+105°C	SC-70-5
G692LxxxTAU	G692LxxxTAUf	-40°C~+105°C	SC-70-5
G693LxxxTAU	G693LxxxTAUf	-40°C~+105°C	SC-70-5

xxx specifies the threshold

e.g. 263 denotes voltage the 2.64V threshold voltage.

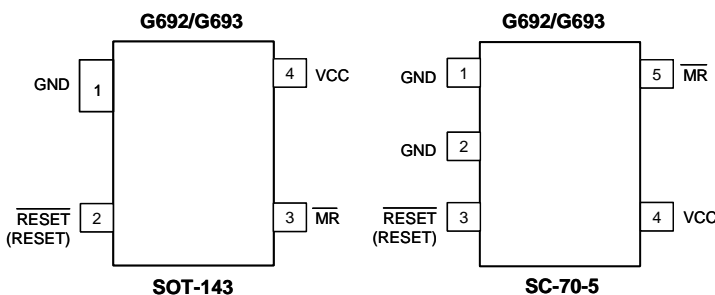
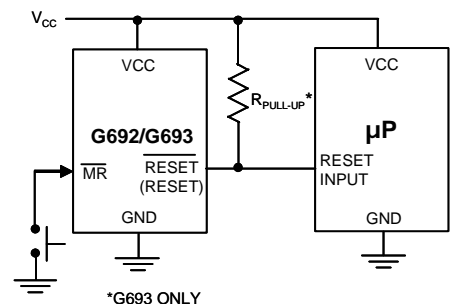
Pin Configuration**Typical Application Circuit**

Selector Guide

ORDER NUMBER	ORDER NUMBER (Pb free)	RESET THRESHOLD (V)	OUTPUT TYPE	TOP MARK
G693L463TCU	G693L463TCUf	4.60	Open-Drain $\overline{\text{RESET}}$	693Fx
G693L438TCU	G693L438TCUf	4.32	Open-Drain $\overline{\text{RESET}}$	693Ex
G693L400TCU	G693L400TCUf	3.96	Open-Drain $\overline{\text{RESET}}$	693Dx
G693L308TCU	G693L308TCUf	3.10	Open-Drain $\overline{\text{RESET}}$	693Cx
G693L293TCU	G693L293TCUf	2.91	Open-Drain $\overline{\text{RESET}}$	693Bx
G693L263TCU	G693L263TCUf	2.64	Open-Drain $\overline{\text{RESET}}$	693Ax
G692H463TCU	G692H463TCUf	4.60	Push-Pull RESET	692Lx
G692H438TCU	G692H438TCUf	4.32	Push-Pull RESET	692Kx
G692H400TCU	G692H400TCUf	3.96	Push-Pull RESET	692Jx
G692H308TCU	G692H308TCUf	3.10	Push-Pull RESET	692Ix
G692H293TCU	G692H293TCUf	2.91	Push-Pull RESET	692Hx
G692H263TCU	G692H263TCUf	2.64	Push-Pull RESET	692Gx
G692L463TCU	G692L463TCUf	4.60	Push-Pull $\overline{\text{RESET}}$	692Fx
G692L438TCU	G692L438TCUf	4.32	Push-Pull $\overline{\text{RESET}}$	692Ex
G692L400TCU	G692L400TCUf	3.96	Push-Pull $\overline{\text{RESET}}$	692Dx
G692L308TCU	G692L308TCUf	3.10	Push-Pull $\overline{\text{RESET}}$	692Cx
G692L293TCU	G692L293TCUf	2.91	Push-Pull $\overline{\text{RESET}}$	692Bx
G692L263TCU	G692L263TCUf	2.64	Push-Pull $\overline{\text{RESET}}$	692Ax

Note: TC: SOT-143

Selector Guide

ORDER NUMBER	ORDER NUMBER (Pb free)	RESET THRESHOLD (V)	OUTPUT TYPE	TOP MARK
G693L463TAU	G693L463TAUf	4.60	Open-Drain $\overline{\text{RESET}}$	63Fx
G693L438TAU	G693L438TAUf	4.32	Open-Drain $\overline{\text{RESET}}$	63Ex
G693L400TAU	G693L400TAUf	3.96	Open-Drain $\overline{\text{RESET}}$	63Dx
G693L308TAU	G693L308TAUf	3.10	Open-Drain $\overline{\text{RESET}}$	63Cx
G693L293TAU	G693L293TAUf	2.91	Open-Drain $\overline{\text{RESET}}$	63Bx
G693L263TAU	G693L263TAUf	2.64	Open-Drain $\overline{\text{RESET}}$	63Ax
G692H463TAU	G692H463TAUf	4.60	Push-Pull RESET	62Lx
G692H438TAU	G692H438TAUf	4.32	Push-Pull RESET	62Kx
G692H400TAU	G692H400TAUf	3.96	Push-Pull RESET	62Jx
G692H308TAU	G692H308TAUf	3.10	Push-Pull RESET	62Ix
G692H293TAU	G692H293TAUf	2.91	Push-Pull RESET	62Hx
G692H263TAU	G692H263TAUf	2.64	Push-Pull RESET	62Gx
G692L463TAU	G692L463TAUf	4.60	Push-Pull $\overline{\text{RESET}}$	62Fx
G692L438TAU	G692L438TAUf	4.32	Push-Pull $\overline{\text{RESET}}$	62Ex (692Fx)
G692L400TAU	G692L400TAUf	3.96	Push-Pull $\overline{\text{RESET}}$	62Dx (692Ex)
G692L308TAU	G692L308TAUf	3.10	Push-Pull $\overline{\text{RESET}}$	62Cx (692Cx)
G692L293TAU	G692L293TAUf	2.91	Push-Pull $\overline{\text{RESET}}$	62Bx (692Bx)
G692L263TAU	G692L263TAUf	2.64	Push-Pull $\overline{\text{RESET}}$	62Ax (692Ax)

Note: TA: SC-70-5

TOP MARK in () is for engineering samples.

**Absolute Maximum Ratings**

Terminal Voltage (with respect to GND)	
V_{CC}	-0.3V to 6.0V
RESET, $\overline{\text{RESET}}$ (push-pull)	-0.3V to ($V_{CC} + 0.3V$)
$\overline{\text{RESET}}$ (open drain)	-0.3V to 6.0V
Input Current, V_{CC}	20mA
Output Current, RESET, $\overline{\text{RESET}}$	20mA

Continuous Power Dissipation ($T_A = 70^\circ\text{C}$)	
SOT-143 (derate 4mW/ $^\circ\text{C}$ above 70°C)	320mW
SC-70-5 (derate 4mW/ $^\circ\text{C}$ above 70°C)	200mW
Operating Temperature Range	-40 $^\circ\text{C}$ to 105 $^\circ\text{C}$
Storage Temperature Range	-65 $^\circ\text{C}$ to +150 $^\circ\text{C}$
Reflow Temperature (soldering, 10s)	260 $^\circ\text{C}$

Stresses beyond those listed under "Absolute Maximum Ratings" may cause permanent damage to the device. These are stress ratings only, and functional operation of the device at these or any other conditions beyond those indicated in the operational sections of the specifications is not implied. Exposure to absolute maximum rating conditions for extended periods may affect device reliability.

Electrical Characteristics

(V_{CC} = full range, $T_A = -40^\circ\text{C}$ to $+105^\circ\text{C}$, unless otherwise noted. Typical values are at $T_A = +25^\circ\text{C}$, $V_{CC} = 5V$ for 463/438/400/330 versions, $V_{CC} = 3.3V$ for 308/293 versions, and $V_{CC} = 3V$ for 263 version.) (Note 1)

PARAMETER	SYMBOL	CONDITION	MIN	TYP	MAX	UNIT
V _{CC} Range		T _A = 0 $^\circ\text{C}$ +70 $^\circ\text{C}$	1.00	---	5.5	V
		T _A = -40 $^\circ\text{C}$ +105 $^\circ\text{C}$	1.20	---	5.5	
Supply Current	I _{CC}	V _{CC} <5.5V, G69_ _463/438/400/330_	---	16.5	25	μA
		V _{CC} <3.6V, G69_ _308/293/263_	---	13.9	22	
Reset Threshold	V _{TH}	G69_ _463_	4.50	4.60	4.69	V
		G69_ _438_	4.23	4.32	4.40	
		G69_ _400_	3.88	3.96	4.04	
		G69_ _308_	3.04	3.10	3.16	
		G69_ _293_	2.86	2.91	2.96	
		G69_ _263_	2.59	2.64	2.69	
Reset Threshold Tempco			---	70	---	ppm/ $^\circ\text{C}$
V _{CC} to Reset Delay (Note 2)		V _{CC} = V _{TH} to (V _{TH} - 100mV)	---	15	---	
Reset Active Timeout Period		V _{CC} = V _{TH} max, G69_ _463/438/400	230	390	510	ms
		V _{CC} = V _{TH} max, G69_ _308/293/263	230	370	510	
$\overline{\text{MR}}$ Minima Pulse Width	t _{MR}		---	10	---	μs
$\overline{\text{MR}}$ Glitch Immunity (Note 3)			---	100	---	ns
$\overline{\text{MR}}$ to Reset Propagation Delay (Note 2)	t _{MD}		---	0.5	---	μs
$\overline{\text{MR}}$ Input Threshold	V _{IH}	V _{CC} > V _{TH(max)}	0.6V _{CC}	0.7V _{CC}	---	V
	V _{IL}		---	0.2V _{CC}	0.3V _{CC}	
$\overline{\text{MR}}$ Pull-up Resistance			10	21	30	K Ω
RESET Output Current Low (push-pull active low, and open-drain active-low, G692L and G693L)	I _{OL}	V _{CC} = 2.5V, V $\overline{\text{RESET}}$ = 0.5V	8	---	---	mA
RESET Output Current High (push-pull active low, G692L)	I _{OH}	V _{CC} = 5V, V $\overline{\text{RESET}}$ = 4.5V, G692L463/438/400	4.5	---	---	mA
		V _{CC} = 3.3V, V $\overline{\text{RESET}}$ = 2.8V, G692L308/293	3	---	---	
		V _{CC} = 3V, V $\overline{\text{RESET}}$ = 2.5V, G692L263	2	---	---	
RESET Output Current Low (push-pull active high, G692H)	I _{OL}	V _{CC} = 5V, V $\overline{\text{RESET}}$ = 0.5V, G692H463/438/400	16	---	---	mA
		V _{CC} = 3.3V, V $\overline{\text{RESET}}$ = 0.5V, G692H308/293	12	---	---	
		V _{CC} = 3V, V $\overline{\text{RESET}}$ = 0.5V, G692H263	10	---	---	
RESET Output Current High (push-pull active high, G692H)	I _{OH}	V _{CC} = 2.5V, V $\overline{\text{RESET}}$ = 2V	2	---	---	mA
RESET Open-Drain Output Leakage Current (G693L)		V _{CC} > V _{TH} , $\overline{\text{RESET}}$ deasserted	---	---	1	μA

Note 1: Production testing done at T_A = +25 $^\circ\text{C}$; limits over temperature guaranteed by design.

Note 2: $\overline{\text{RESET}}$ output is for G692L/G693L; While RESET output is for G692H.

Note 3: "Glitches" of 100ns or less typically will not generate a reset pulse.

Typical Operating Characteristics

(V_{CC} = full range, T_A = -40°C to $+105^{\circ}\text{C}$, unless otherwise noted. Typical values are at T_A = $+25^{\circ}\text{C}$, V_{CC} = 5V for 463/438/400 versions, V_{CC} = 3.3V for 308/293/263 versions, and V_{CC} = 3V for 263 version.)

Supply Current vs. Temperature
(No Load)

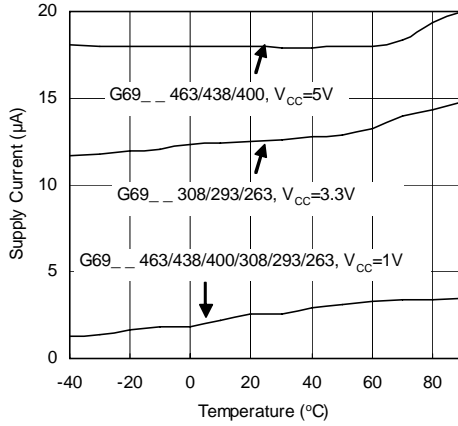

Power-down Reset Delay vs. Temperature
(G69_ 308/293/263)

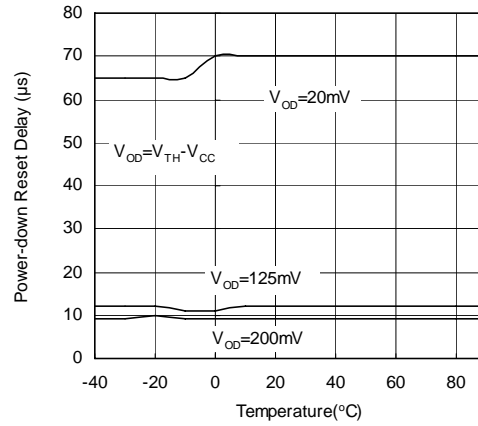

Power-up Reset Timeout
vs. Temperature

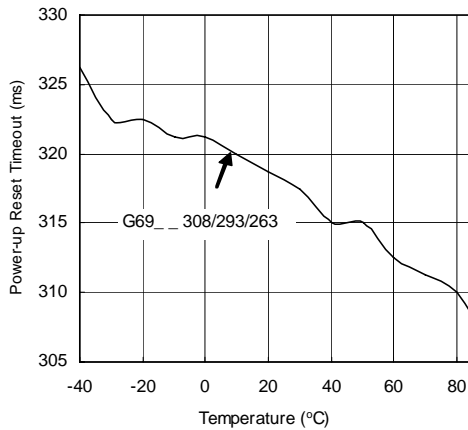

Normalized Reset Threshold
vs. Temperature

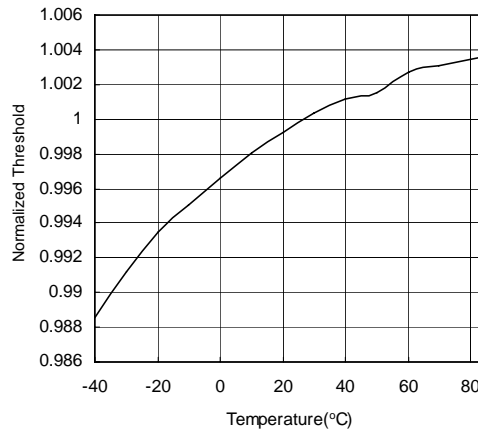

Recommended Minimum Footprint

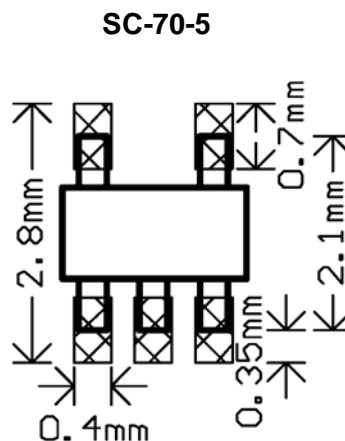
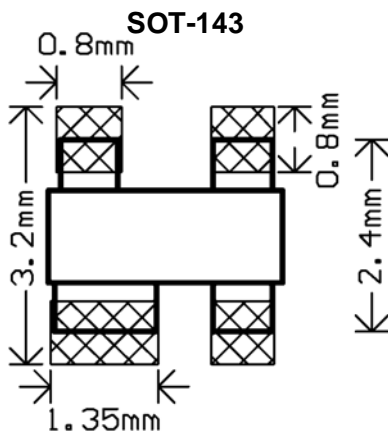

Pin Description

PIN		NAME	FUNCTION
SOT-143	SC-70-5		
1	1,2	GND	Ground
2	3	$\overline{\text{RESET}}$ (G693L/G692L)	$\overline{\text{RESET}}$ Output remains low while V_{CC} is below the reset threshold, and for at least 140ms after V_{CC} rises above the reset threshold.
		$\overline{\text{RESET}}$ (G692H)	$\overline{\text{RESET}}$ Output remains high while V_{CC} is below the reset threshold, and for at least 140ms after V_{CC} rises above the reset threshold.
3	5	$\overline{\text{MR}}$	Manual Reset Input. A logic low on $\overline{\text{MR}}$ asserts reset. Reset remains asserted as long as $\overline{\text{MR}}$ is low and for at least 140ms after $\overline{\text{MR}}$ returns high. This active-low input has an internal 20k Ω pull-up resistor. It can be driven from a TTL or CMOS-logic line, or shorted to ground with a switch. Leave open if unused.
4	4	VCC	Supply Voltage (+5V, +3.3V, +3.0V)

Detailed Description

A microprocessor's (μP 's) reset input starts the μP in a known state. The G693L/G692L/G692H assert reset to prevent code-execution errors during power-up, power-down, or brownout conditions. They assert a reset signal whenever the V_{CC} supply voltage declines below a preset threshold, keeping it asserted for at least 140ms after V_{CC} has risen above the reset threshold. The G693L uses an open-drain output, and the G692L/G692H have a push-pull output stage. Connect a pull-up resistor on the G693L's $\overline{\text{RESET}}$ output to any supply between 0 and 5.5V.

The manual reset input ($\overline{\text{MR}}$) can also initiate a reset. See the Manual Reset Input Section.

Manual Reset Input

Many μP -based products require manual reset capability, allowing the operator, a test technician, or external logic circuitry to initiate a reset. A logic low on $\overline{\text{MR}}$ asserts reset. Reset remains asserted while $\overline{\text{MR}}$ is low, and for the Reset Active Timeout Period (t_{RP}) after $\overline{\text{MR}}$ returns high. This input has an internal 20k Ω pull-up resistor, so it can be left open if it is not used. $\overline{\text{MR}}$ can be driven with TTL or CMOS-logic levels, or with open-drain / collector outputs. Connect a normally open momentary switch from $\overline{\text{MR}}$ to GND to create a manual-reset function; external debounce circuitry is not required. If $\overline{\text{MR}}$ is driven from long cables or if the device is used in a noisy environment, connecting a 0.1 μF capacitor from $\overline{\text{MR}}$ to ground provides additional noise immunity.

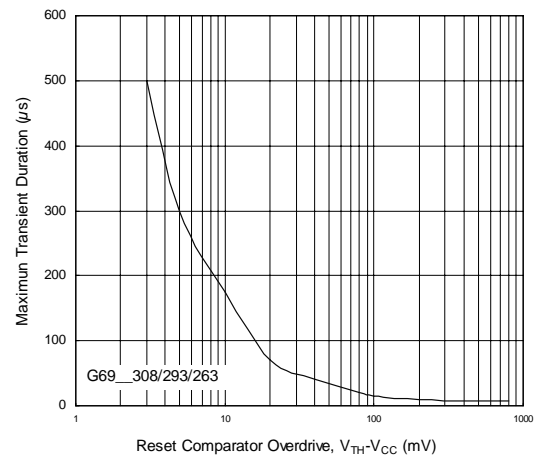

Figure1. Maximum Transient Duration without Causing a Reset Pulse vs. Reset Comparator Overdrive

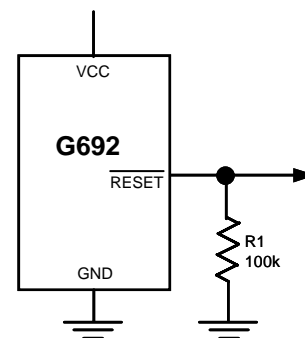

Figure2. $\overline{\text{RESET}}$ Valid to $V_{CC} = \text{Ground}$ Circuit

Applications Information

Negative-Going V_{CC} Transients

In addition to issuing a reset to the μP during power-up, power-down, and brownout conditions, the G693L/G692H/G692L are relatively immune to short-duration negative-going V_{CC} transients (glitches).

Figure1 shows typical transient duration vs. reset comparator overdrive, for which the G693L/G692H/G692L do not generate a reset pulse. The graph was generated using a negative-going pulse applied to V_{CC}, starting 0.5V above the actual reset threshold and ending below it by the magnitude indicated (reset comparator overdrive). The graph indicates the maximum pulse width a negative-going V_{CC} transient can have without causing a reset pulse. As the magnitude of the transient increases (goes farther below the reset threshold), the maximum allowable pulse width decreases. Typically, for the G69_463 and G69_438, a V_{CC} transient that goes 100mV below the reset threshold and lasts 15 μs or less will not cause a reset pulse. A 0.1 μF bypass capacitor mounted as close as possible to the V_{CC} pin provides additional transient immunity.

Ensuring a Valid Reset Output Down to V_{CC} = 0

When V_{CC} falls below 1V, the G692 RESET output no longer sinks current—it becomes an open circuit. Therefore, high-impedance CMOS logic inputs connected to RESET can drift to undetermined voltages. This presents no problem in most applications since most μP and other circuitry is inoperative with V_{CC} below 1V. However, in applications where RESET must be valid down to 0V, adding a pull-down resistor to RESET causes any stray leakage currents to flow to ground, holding RESET low (Figure 2). R1's value is not critical; 100k Ω is large enough not to load RESET and small enough to pull RESET to ground.

A 100k Ω pull-up resistor to V_{CC} is also recommended for the G693L if RESET is required to remain valid for V_{CC} < 1V.

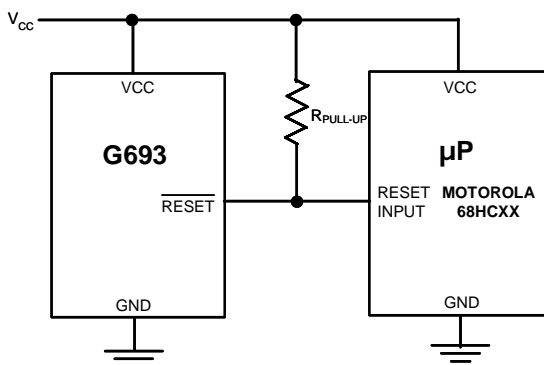

Figure3. Interfacing to μP s with Bidirectional Reset I/O

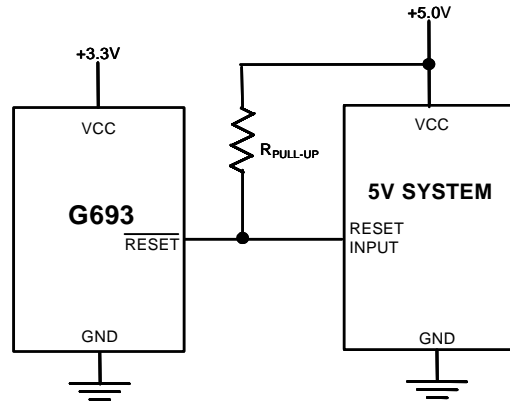

Figure4. G693L Open-Drain RESET Output Allows Use with Multiple Supplies

Interfacing to μP s with Bidirectional Reset Pins

Since the RESET output on the G693L is open drain, this device interfaces easily with μP s that have bidirectional reset pins, such as the Motorola 68HC11. Connecting the μP supervisor's RESET output directly to the microcontroller's (μC 's) RESET pin with a single pull-up resistor allows either device to assert reset (Figure 3).

G693L Open-Drain RESET Output Allows Use with Multiple Supplies

Generally, the pull-up connected to the G693L will connect to the supply voltage that is being monitored at the IC's V_{CC} pin. However, some systems may use the open-drain output to level-shift from the monitored supply to reset circuitry powered by some other supply (Figure 4). Note that as the G693L's V_{CC} decreases below 1V, so does the IC's ability to sink current at RESET. Also, with any pull-up, RESET will be pulled high as V_{CC} decays toward 0. The voltage where this occurs depends on the pull-up resistor value and the voltage to which it is connected.

Benefits of Highly Accurate Reset Threshold

Most μP supervisor ICs have reset threshold voltages between 5% and 10% below the value of nominal supply voltages. This ensures a reset will not occur within 5% of the nominal supply, but will occur when the supply is 10% below nominal.

When using ICs rated at only the nominal supply $\pm 5\%$, this leaves a zone of uncertainty where the supply is between 5% and 10% low, and where the reset may or may not be asserted.

The G69_463/G69_308 use highly accurate circuitry to ensure that reset is asserted close to the 5% limit, and long before the supply has declined to 10% below nominal.



Package Information

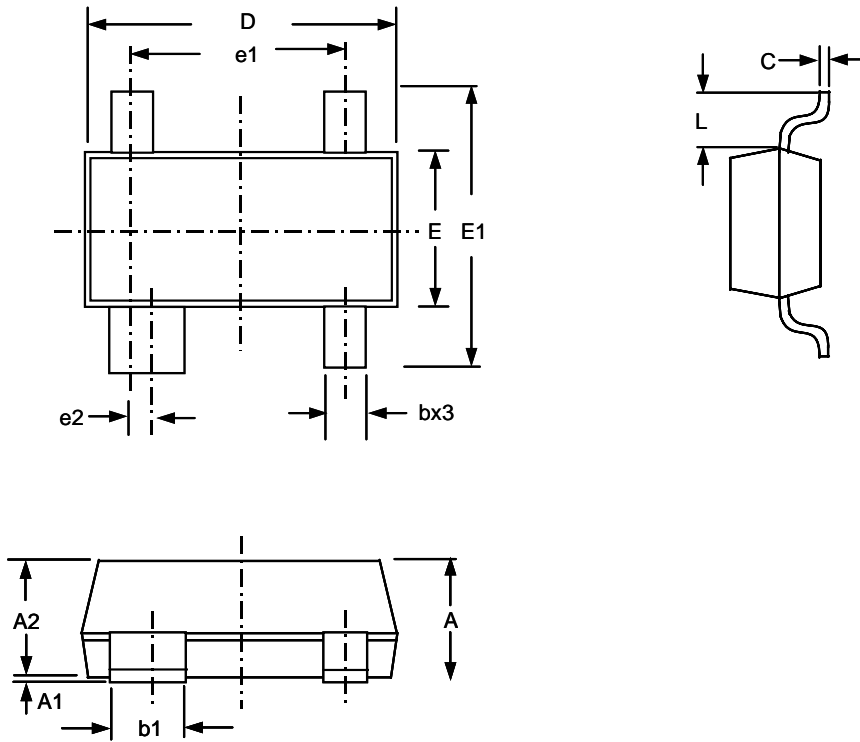

SOT-143 (TC) Package

SYMBOL	DIMENSION IN MILLIMETERS		DIMENSION IN INCHS	
	MIN.	MAX.	MIN.	MAX.
A	0.95	1.20	0.037	0.047
A1	0.05	0.10	0.002	0.004
A2	0.90	1.10	0.035	0.043
b	0.37	0.46	0.145	0.018
b1	0.76	0.89	0.030	0.035
C	0.10	0.18	0.004	0.007
D	2.80	3.04	0.110	0.120
E	1.20	1.40	0.047	0.055
E1	2.30	2.50	0.091	0.098
e1	1.92 BSC.		0.75 BSC.	
e2	0.20 BSC.		0.078 BSC.	
L	0.69 REF.		0.27 REF.	

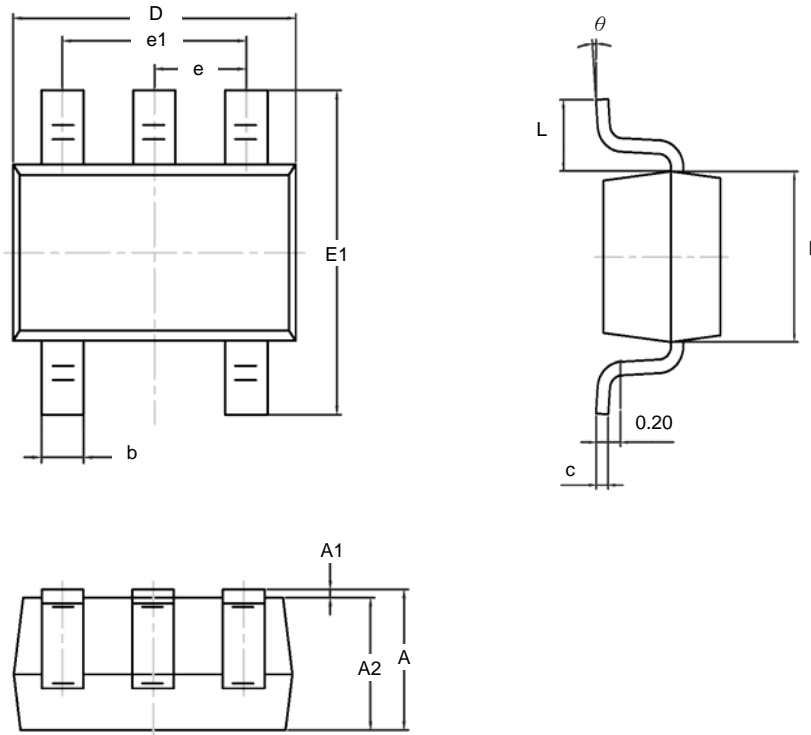

SC-70-5 (TA) Package

SYMBOL	DIMENSION IN MM			DIMENSION IN INCH		
	MIN.	NOM.	MAX.	MIN.	NOM.	MAX.
A	0.80	-----	1.10	0.031	-----	0.043
A1	0.00	-----	0.10	0.000	-----	0.004
A2	0.80	0.90	1.00	0.031	0.035	0.040
b	0.15	-----	0.30	0.006	-----	0.012
c	0.08	-----	0.25	0.003	-----	0.010
D	1.90	2.10	2.15	0.075	0.083	0.085
E1	2.00	2.10	2.20	0.078	0.083	0.087
E	1.15	1.25	1.35	0.045	0.049	0.053
e	0.65 BSC			0.0256 BSC		
e1	1.30 BSC			0.0512 BSC		
L	0.26	0.36	0.46	0.010	0.014	0.018
θ	0°	-----	8°	0°	-----	8°

Taping Specification

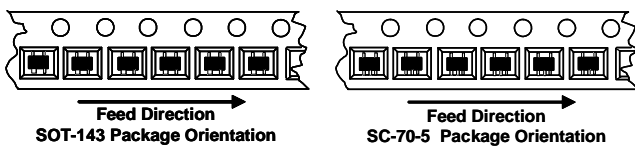

PACKAGE	Q'TY/REEL
SOT-143	3,000 ea
SC-70-5	3,000 ea

GMT Inc. does not assume any responsibility for use of any circuitry described, no circuit patent licenses are implied and GMT Inc. reserves the right at any time without notice to change said circuitry and specifications.