

# QPL QUALIFIED MIL-DTL-38999 Series IV, Breech Coupling 38999/43 jam-nut mount receptacle



SERIES IV HERMETIC

QPL Part Number Development						
<b>Sample Part Number</b>	D38999/43 Y B 35 P N					
<b>D38999</b>	38999/43 = Jam-Nut receptacle					
<b>Class</b>	N = Hermetic, CRES, nickel finish, conductive, -65°C to 200°C Y = Hermetic, CRES, passivate finish, conductive, -65°C to 200°C					
<b>Shell Size</b>	B, C, D, E, F, G, H, J					
<b>Insert Arrangement</b>	Per MIL-STD-1560; See reference information section for details					
<b>Contact Style</b>	P = Pin, solder cup S = Socket, solder cup		X = Pin, eyelet Z = Socket, eyelet		C = Pin, PCB flex feedthrough D = Socket, PCB flex feedthrough	
<b>Polarization</b>	N (Normal), A, B, C, D, K, L, M, R; see polarization positions table					



Polarization Position									
	N	A	B	C	D	K	L	M	R
XX	110°	100°	90°	80°	70°	120°	120°	120°	120°
YY	250°	260°	270°	280°	290°	255°	265°	275°	285°

Wire Accommodation	
Contact Size	Wire Gauge
22D	#22 - #28
20	#20 - #24
16	#16 - #20
12	#12 - #14

Contact Size	
FEEDTHROUGH CONTACT STYLE C AND D	
SIZE 12 AND SIZE 16	
SIZE 22D AND SIZE 20	
Contact Size	ø P
22D	.011 (0.28) .015 (0.38)
20	.024 (0.61) .028 (0.71)
16	.0635 (1.61) .0615 (1.56)
12	.095 (2.41) .093 (2.36)

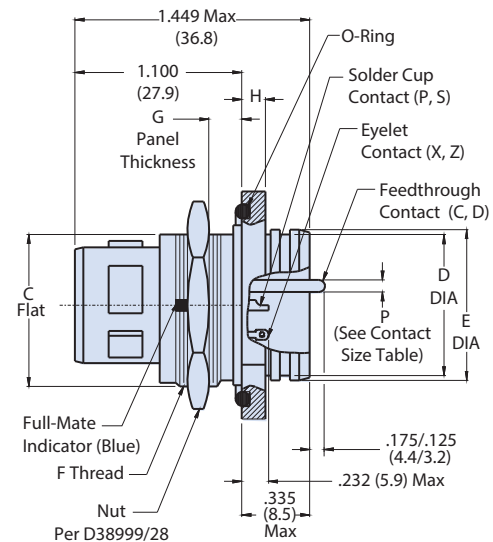
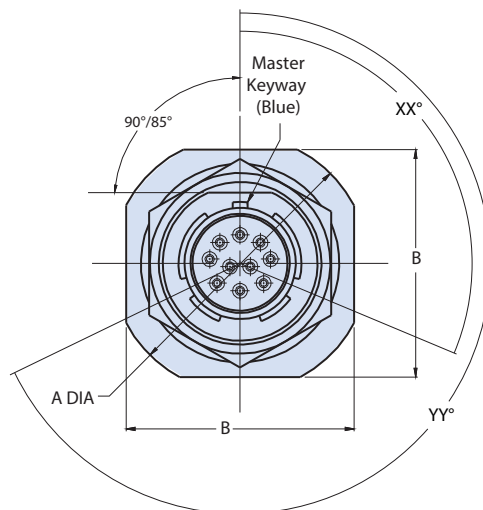

# COTS EQUIVALENT MIL-DTL-38999 Series IV, Breech Coupling 234-100-H7 jam-nut mount receptacle



SERIES IV HERMETIC

COTS Part Number Development						
Sample Part Number	234-100-H7	Z1	11	-35	P	N
Series / Basic Part No.	234-100-H7 = Hermetic, jam-nut mount hermetic receptacle					
Material/Finish	ZL = CRES, nickel finish, conductive, -65°C to 200°C Z1 = CRES, passivate finish, conductive, -65°C to 200°C					
Shell Size	11, 13, 15, 17, 19, 21, 23, 25					
Insert Arrangement	Per MIL-STD-1560; See reference information section for details					
Contact Style	P = Pin, solder cup      X = Pin, eyelet      C = Pin, PCB flex feedthrough S = Socket, solder cup      Z = Socket, eyelet      D = Socket, PCB flex feedthrough					
Polarization	N (Normal), A, B, C, D, K, L, M, R see polarization position position table					

Additional material/finish options are available, consult factory for ordering information.

Dimensions									
SHELL SIZE CODE	SHELL SIZE	A DIA	B	C FLAT	D DIA	E DIA ±.010(0.3)	F THREAD ISO METRIC 1.0-6g	G ±.033(0.8)	H ±.012(0.3)
B	11	1.385(35.2) 1.362(34.6)	1.267 (32.18) 1.232 (31.29)	.754(19.2) .745(18.9)	.732(18.6) .716(18.2)	.769(19.5)	M20	.092(2.3)	.106(2.7)
C	13	1.511(38.4) 1.488(37.8)	1.393 (35.38) 1.358 (34.49)	.941(23.9) .932(23.7)	.858(21.8) .839(21.3)	.899(22.8)	M25	.092(2.3)	.106(2.7)
D	15	1.637(41.6) 1.614(41.0)	1.519 (38.58) 1.484 (37.69)	1.065(27.1) 1.056(26.8)	.984(25.0) .968(24.6)	1.025(26.0)	M28	.092(2.3)	.106(2.7)
E	17	1.763(44.8) 1.740(44.2)	1.641 (41.68) 1.606 (40.79)	1.190(30.2) 1.181(30.0)	1.110(28.2) 1.091(27.7)	1.147(29.1)	M32	.092(2.3)	.106(2.7)
F	19	1.948(49.5) 1.925(48.9)	1.830 (46.48) 1.795 (45.59)	1.316(33.4) 1.306(33.2)	1.236(31.4) 1.220(31.0)	1.273(32.3)	M35	.092(2.3)	.137(3.5)
G	21	2.074(52.7) 2.051(52.1)	1.956 (49.68) 1.921 (48.79)	1.441(36.6) 1.431(36.3)	1.358(34.5) 1.342(34.1)	1.399(35.5)	M38	.092(2.3)	.137(3.5)
H	23	2.200(55.9) 2.177(55.3)	2.078 (52.78) 2.043 (51.89)	1.565(39.8) 1.556(39.5)	1.484(37.7) 1.468(37.3)	1.525(38.7)	M41	.092(2.3)	.137(3.5)
J	25	2.326(59.1) 2.299(58.4)	2.204 (55.98) 2.169 (55.09)	1.692(43.0) 1.681(42.7)	1.610(40.9) 1.594(40.5)	1.647(41.8)	M44	.092(2.3)	.137(3.5)

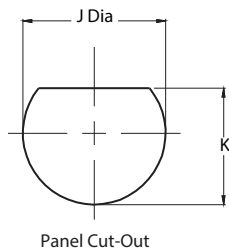

Panel Cut-Out Dimensions					
Shell Size Code	J Dia	K	Shell Size Code	J Dia	K
B	.835 (21.21)	.771 (19.58)	F	1.395 (35.43)	1.335 (33.91)
	.825 (20.96)	.761 (19.33)		1.385 (35.18)	1.325 (33.66)
C	1.020 (25.91)	.955 (24.26)	G	1.520 (38.61)	1.460 (37.08)
	1.010 (25.65)	.945 (24.00)		1.510 (38.35)	1.450 (36.83)
D	1.145 (29.08)	1.085 (27.56)	H	1.645 (41.78)	1.585 (40.26)
	1.135 (28.83)	1.075 (27.31)		1.635 (41.53)	1.575 (40.01)
E	1.270 (32.26)	1.210 (30.73)	J	1.770 (44.96)	1.710 (43.43)
	1.260 (32.00)	1.200 (30.48)		1.760 (44.70)	1.700 (43.18)

Additional Material/Finish Options	
Finish Code	Description
Z1S†	CRES, passivate finish, conductive, -65°C to 200°C, space-grade

† Connectors ordered with "Z1S" include outgas processing to conform to outgassing requirements of Class H.