

VGA Connector

SPECIFICATIONS

Mechanical

Connector Mating Force: 5.10kg (11.24Lb) max.
Connector Un mating Force: 0.32kg (0.71Lb) min.
Durability: 500 Cycles

Electrical

Current Rating: 2 A
Contact Resistance: 30 mΩ max.
Dielectric Withstanding Voltage: 500V AC/1min min.
Insulation Resistance: 5000MΩ min.

Physical

Housing: Thermoplastic, UL 94V-0 rated in Black Color
Contact: Copper alloy
Plating: See "ORDERING INFORMATION"
Operating Temperature: -20°C to +85°C
Recommended Thickness of PCB: 2.36[.093]

DZ Series
Right Angle Type, T/H
2.29mm [.090"] Pitch
15 Pos.

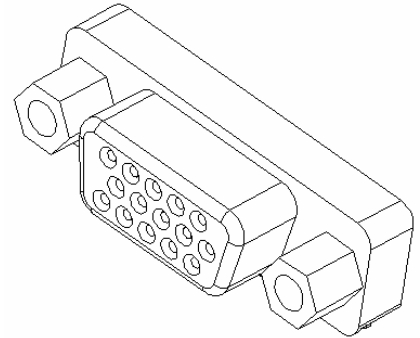

DRAWING

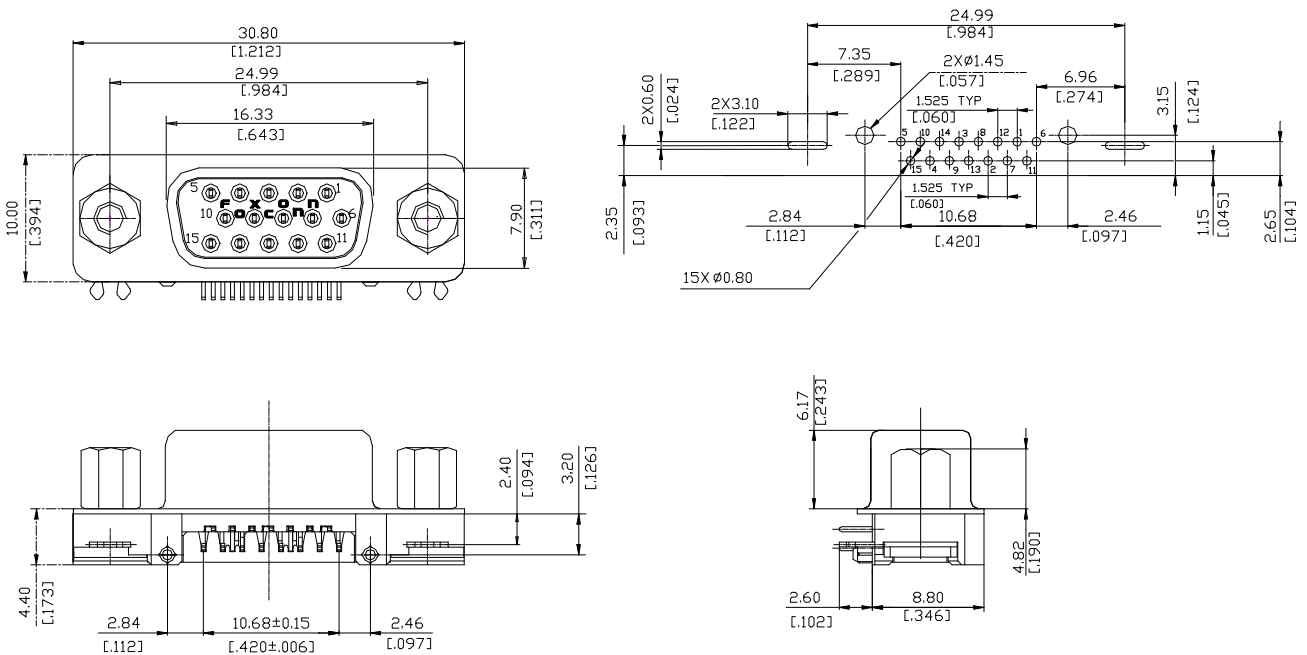

ORDERING INFORMATION

PRODUCT NO.: DZ11A5*- H8R1-4F

