

**SPECIFICATIONS**

**Mechanical**

**Mating force:** 40.0Kgf max.  
**Unmating force:** 4.4Kgf min.  
**Durability:** 30 Cycles

**Electrical**

**Current Rating:** 0.5A max. per contact.  
**Contact Resistance:** 55mΩ max.(Initial), 75mΩ max.(After).  
**Dielectric Withstanding Voltage:** 200 VAC.  
**Insulation Resistance:** 100 mega ohms min. at 500 VDC.

**Physical**

**Housing:** Thermoplastic, UL 94V-0 rated, in White Color  
**Contact:** Copper alloy  
**Plating:** See "ORDERING INFORMATION"  
**Operating Temperature:** -40°C to +85°C

**Board To Board Connector**

**Low Profile Series**  
**Vertical Type**  
**0.5mm Pitch**  
**220 Pos.**

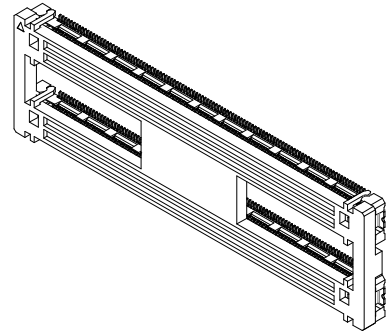

**DRAWING**

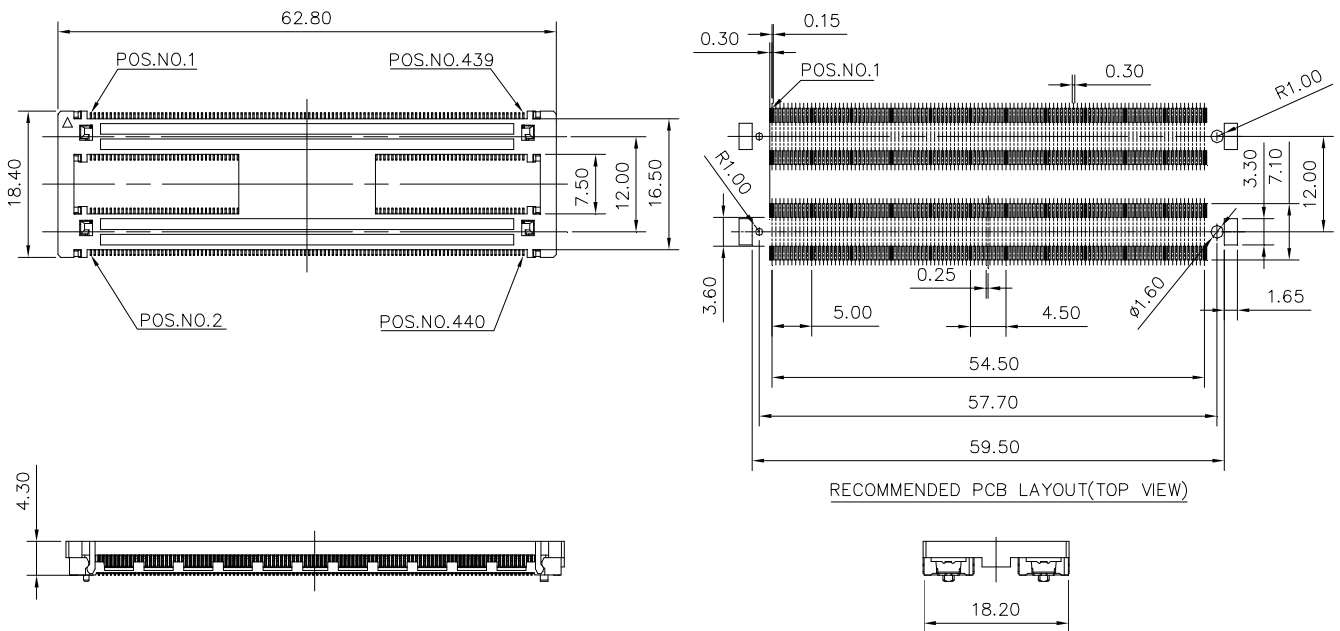

**ORDERING INFORMATION**

**PRODUCT NO.:** Q T 0 1 2 2 0 6 - 1 0 4 1 - 3 H

|            |   |                          |   |               |   |                      |   |                         |   |   |   |   |   |   |   |   |   |   |   |  |
|------------|---|--------------------------|---|---------------|---|----------------------|---|-------------------------|---|---|---|---|---|---|---|---|---|---|---|--|
| Fine Pitch | Q | Board To Board Connector | T | Pitch 0=0.5mm | 0 | Receptacle Connector | 1 | No. of Pos. 220=220Pos. | 2 | 2 | 0 | 6 | - | 1 | 0 | 4 | 1 | - | 3 | H  |
|            |   |                          |   |               |   |                      |   |                         |   |   |   |   |   |   |   |   |   |   |   | H=Halogen Free & Lead Free               |
|            |   |                          |   |               |   |                      |   |                         |   |   |   |   |   |   |   |   |   |   |   | Package Code 3=Hard Tray With Cap        |
|            |   |                          |   |               |   |                      |   |                         |   |   |   |   |   |   |   |   |   |   |   | Com express, 2 IN 1                      |
|            |   |                          |   |               |   |                      |   |                         |   |   |   |   |   |   |   |   |   |   |   | Contact Area Plating 6=10μ" Gold Plating |