

Product Change Notification

PCN Tracking Number:	RLPCN080901
Product Category:	Signal relays
Date:	29 February 2008
Affected Product:	SMT versions of FTR-B3; FTR-B4; FTR-C1 series.

Change description:

Change to Vacuum packed reels and change of inner and outer cartons.
See attachments on page 2 to 7 for packaging details.

Affected part numbers:

FTR-B3 Series	: FTR-B3****-B10
FTR-B4 Series	: FTR-B4****-B05
FTR-C1 Series	: FTR-C1****-B05

Reason for change:

Improved storage characteristics and humidity protection.

Implementation schedule:

March 2008

Anticipated impact:

None: There are no changes to the specification or characteristic to the relay itself.

Customer response:

Please send us your comments, and requirement for detailed information or samples if required, to your Fujitsu account manager.

Disclosure information:

None of this information shall be disclosed or forwarded to other suppliers or distributed outside your company, without approval from Fujitsu Components Europe B.V.

This Product Change Notification will also be available on <https://extranet.fceu.fujitsu.com>

Package Details No-1 : FTR-B3 Series

1. Package Configuration Change

- (1) Vacuum Pack for all reels.
- (2) Cushion Change (Thickness change of cardboard. Abolition of foam polystyrene & Air cap.
- (3) Dimensions of Outer & Inner Carton.

< Present >

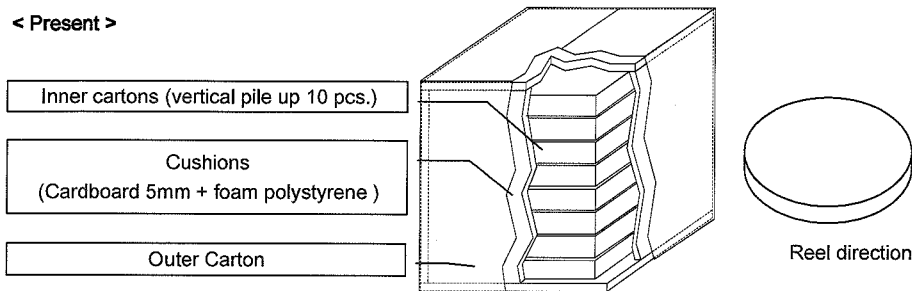

< After Change >

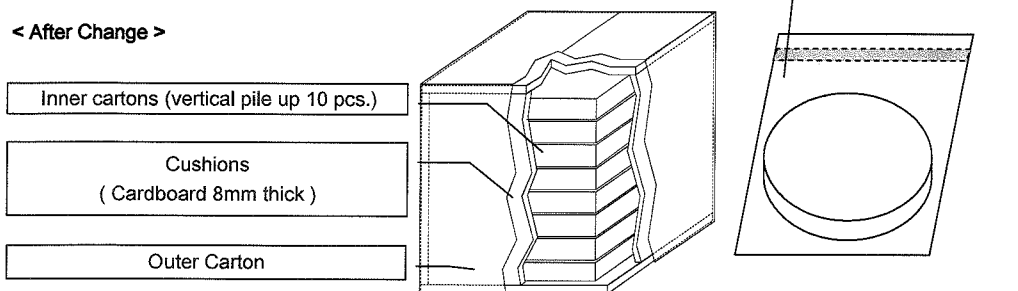

< Picture of Vacuum Pack >

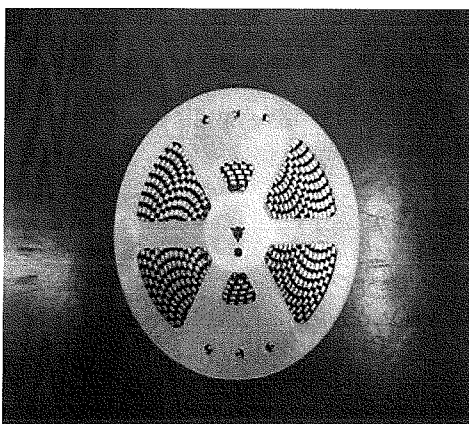

Present

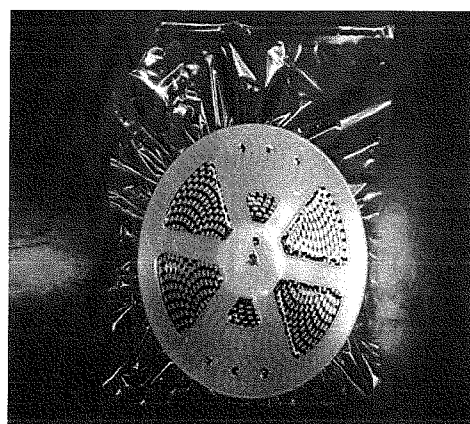

After Change

2. Inner Carton Change

(1) Dimension Change

* RoHS Marking (print) : No change of contents & position.

< Present >

< After Change >

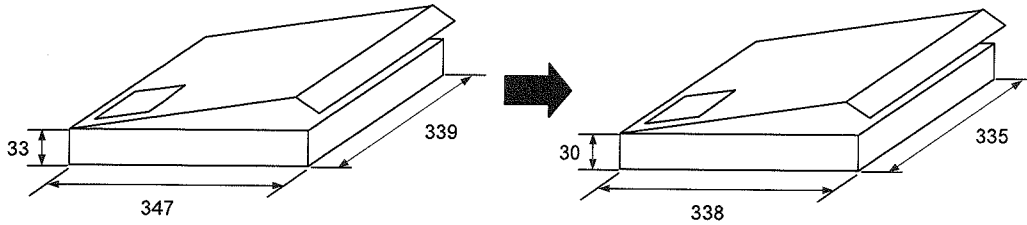

3. Outer Carton Change

(1) Dimension Change

(2) Care mark will be attached for 4 side.

* China RoHS recycle mark, RoHS compliance mark : No change of contents & position.

< Present >

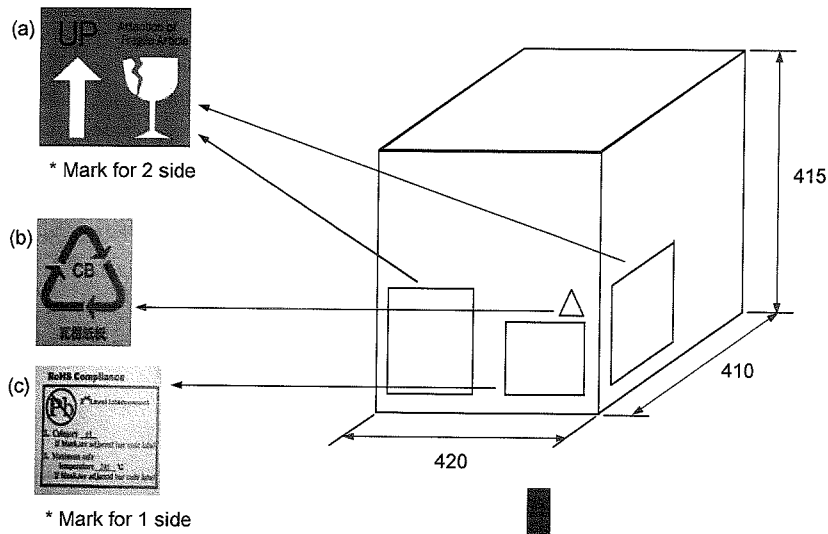

< After Change >

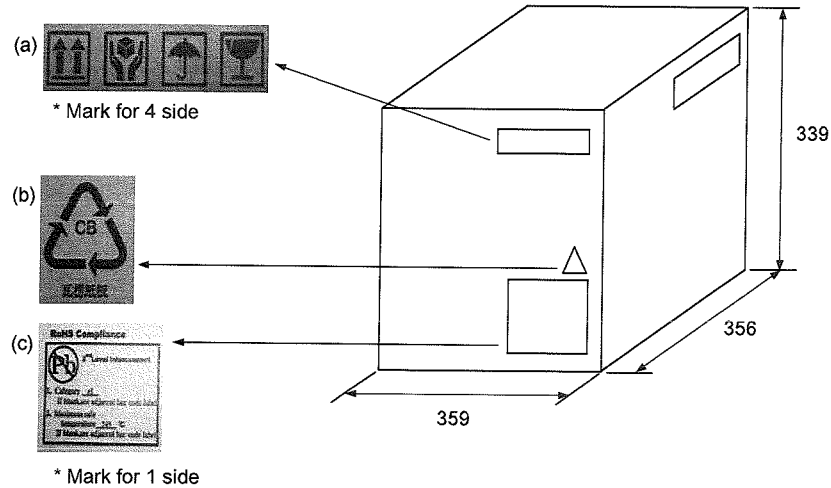

Package Details No-2 : FTR-B4 Series

1. Package Configuration Change

- (1) Vacuum Pack for all reels.
- (2) Cushion Change (Thickness change of cardboard. Abolition of foam polystyrene & Air cap.
- (3) Dimensions of Outer & Inner Carton.

< Present >

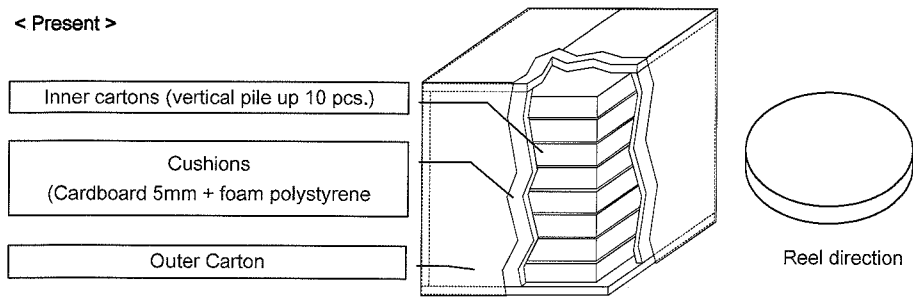

< After Change >

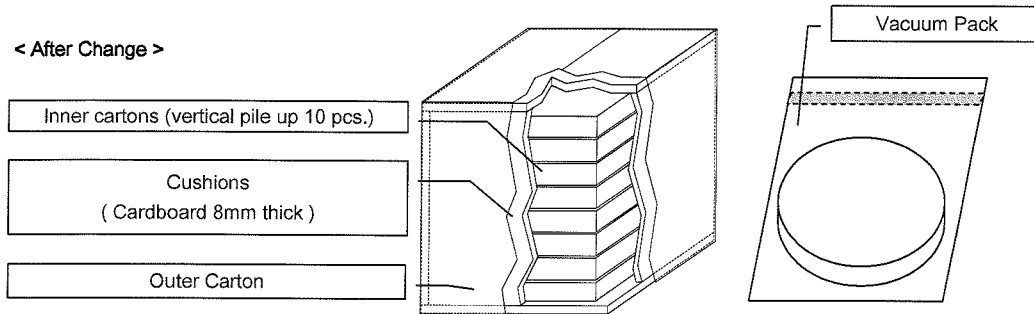

< Picture of Vacuum Pack >

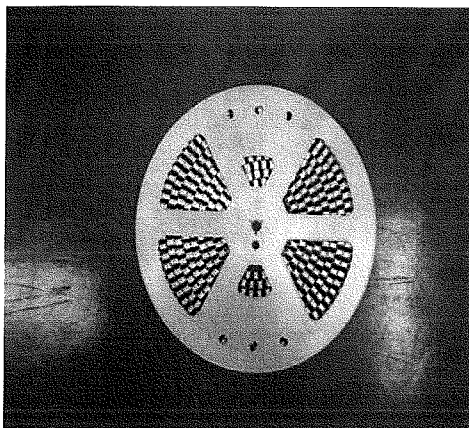

Present

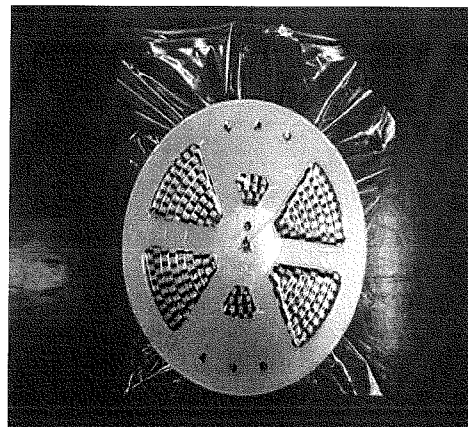

After Change

2. Inner Carton Change

(1) Dimension Change

* RoHS Marking (print) : No change of contents & position.

< Present >

< After Change >

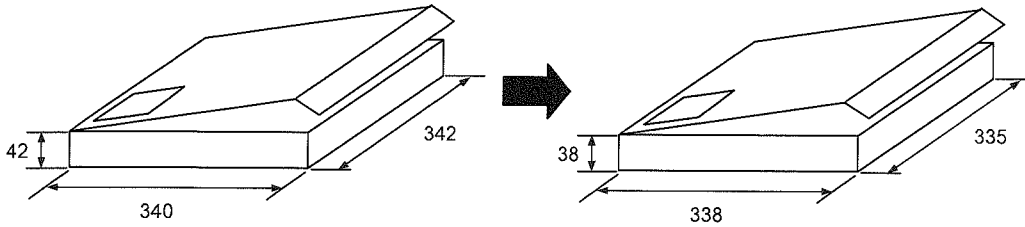

3. Outer Carton Change

(1) Dimension Change

(2) Care mark will be attached for 4 side.

* China RoHS recycle mark, RoHS compliance mark : No change of contents & position.

< Present >

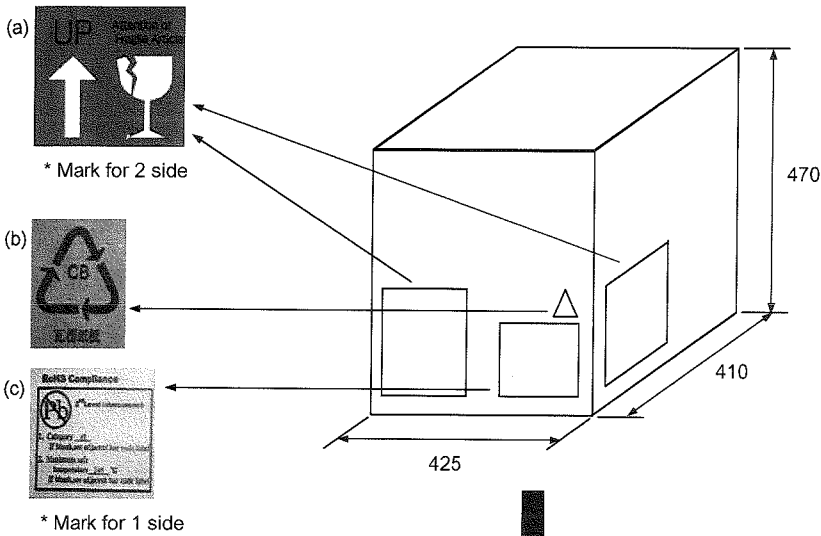

< After Change >

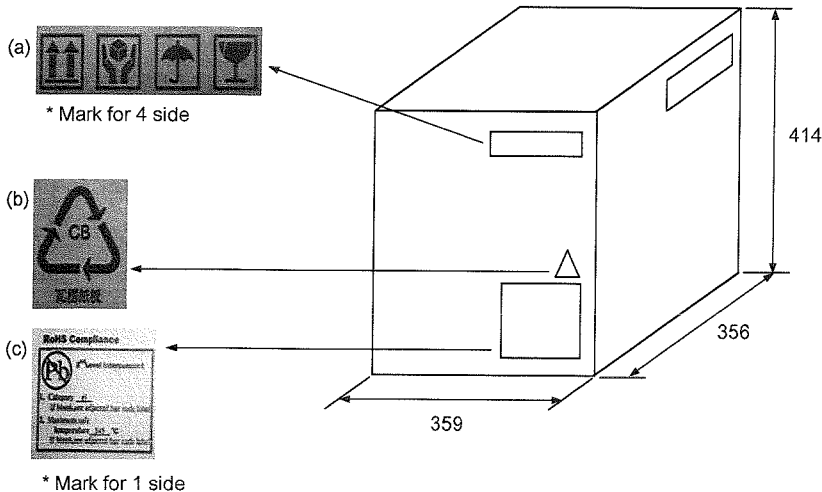

Package Details No-3 : FTR-C1 Series

1. Package Configuration Change

- (1) Vacuum Pack for all reels.
- (2) Cushion Change (Thickness change of cardboard. Abolition of foam polystyrene & Air cap.
- (3) Dimensions of Outer & Inner Carton.

< Present >

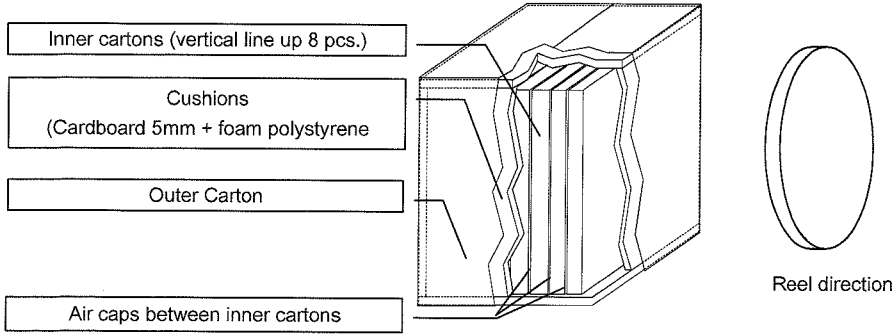

< After Change >

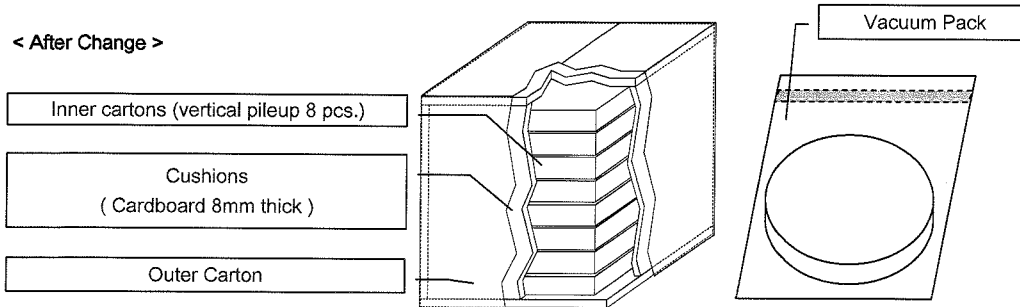

< Picture of Vacuum Pack >

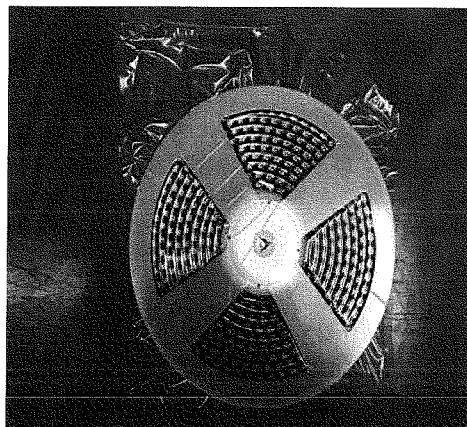
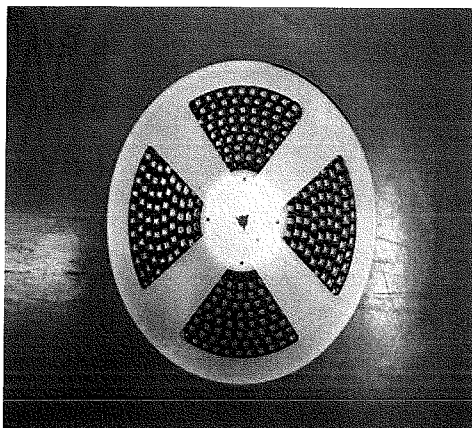

2. Inner Carton Change

(1) Dimension Change

* RoHS Marking (print) : No change of contents & position.

< Present >

< After Change >

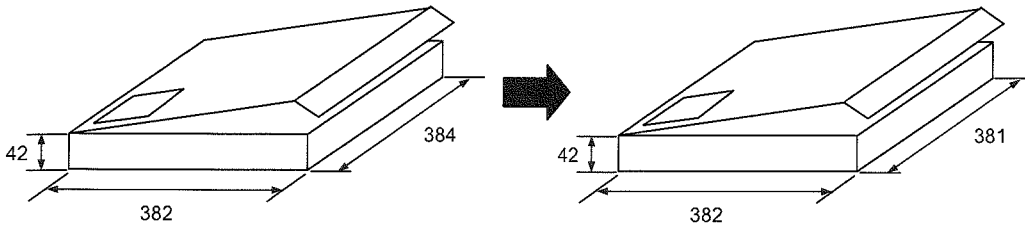

3. Outer Carton Change

(1) Dimension Change

(2) Care mark will be attached for 4 side.

* China RoHS recycle mark, RoHS compliance mark : No change of contents & position.

< Present >

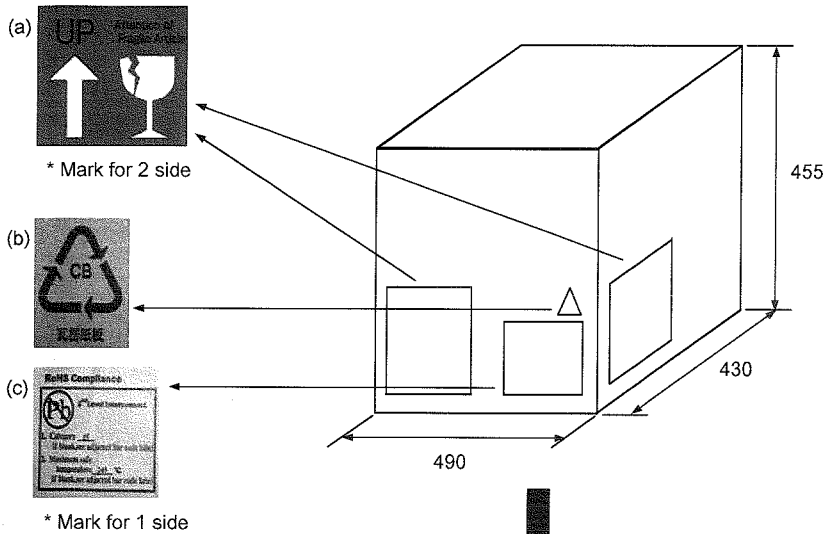

< After Change >

