

PRODUCT NUMBER RPI96B3TF12P1

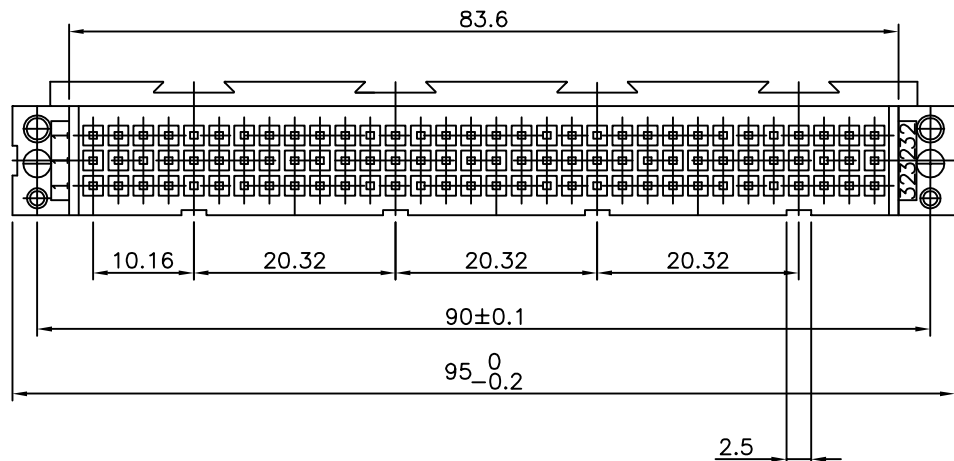

NOTES:-

1. THIS PRODUCT MEETS EUROPEAN UNION DIRECTIVES AND OTHER COUNTRY REGULATIONS AS DESCRIBED IN GS-22-008.
2. LEADFREE OR RoHS DIRECTIVE LABELLING TO BE PROVIDED AS PER GS-14-920.
3. " LF " SUFFIX TO PRODUCT NUMBER FOR RoHS COMPATIBLE/ LEADFREE VERSION.
4. PARTS WITH AND WITHOUT "LF" SUFFIX ARE FORM-FIT AND FUNCTIONALLY IDENTICAL. " LF " SUFFIX PROVIDED FOR PART NUMBER STANDARDISATION OF PART THAT MEETS RoHS REQUIREMENTS.

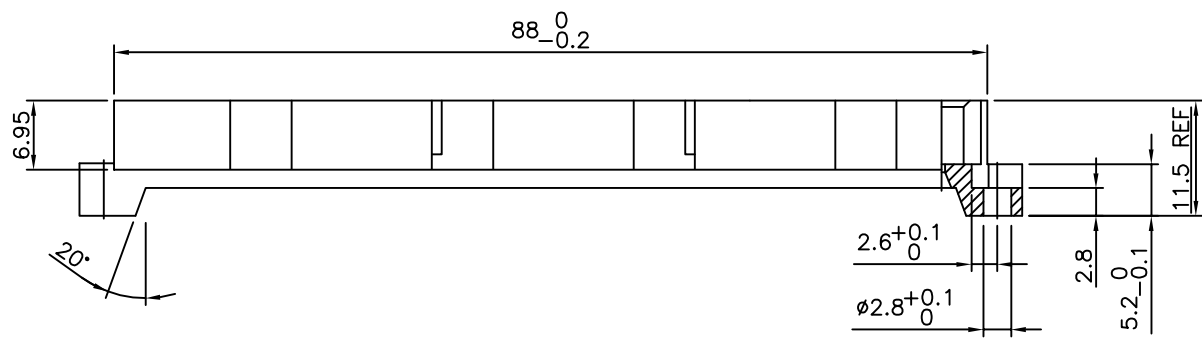
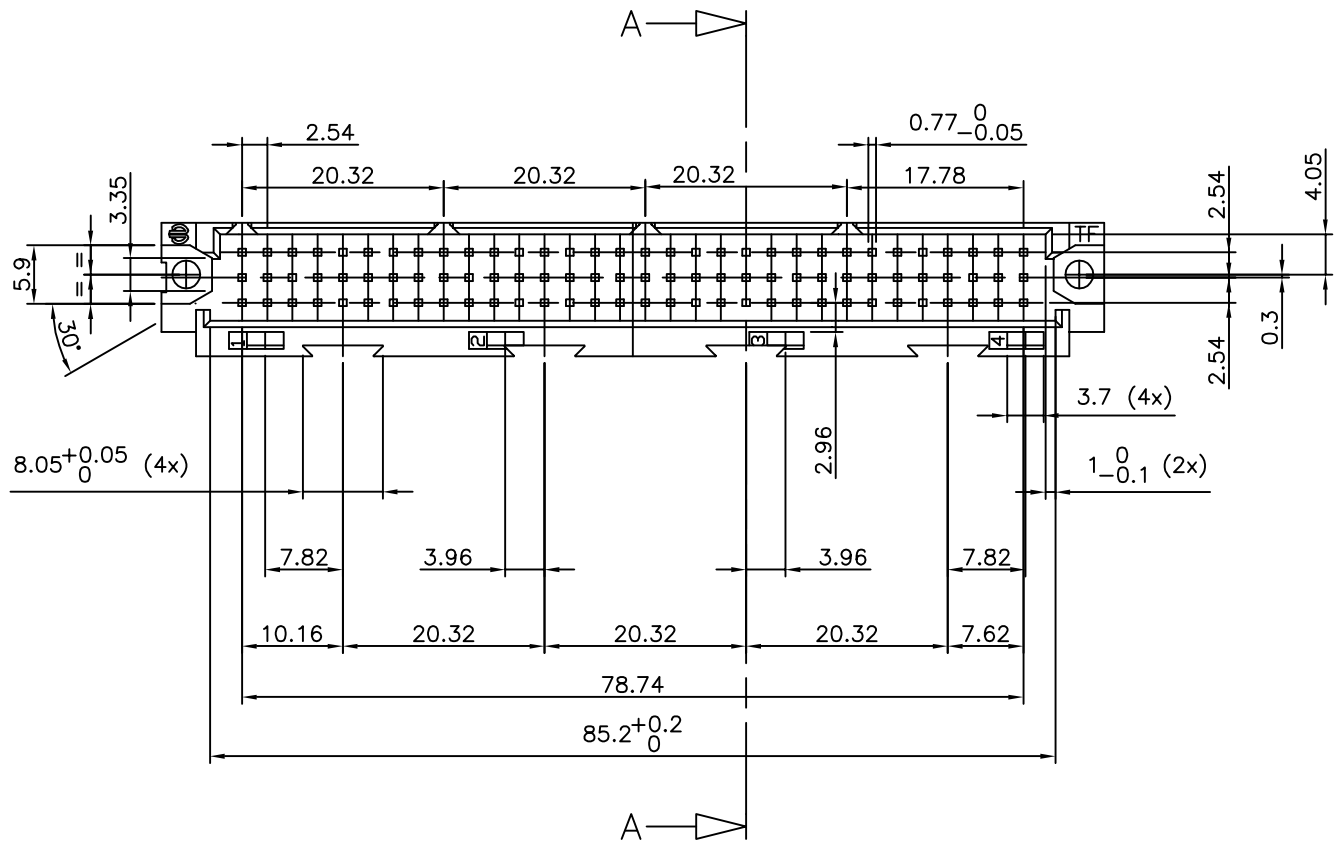
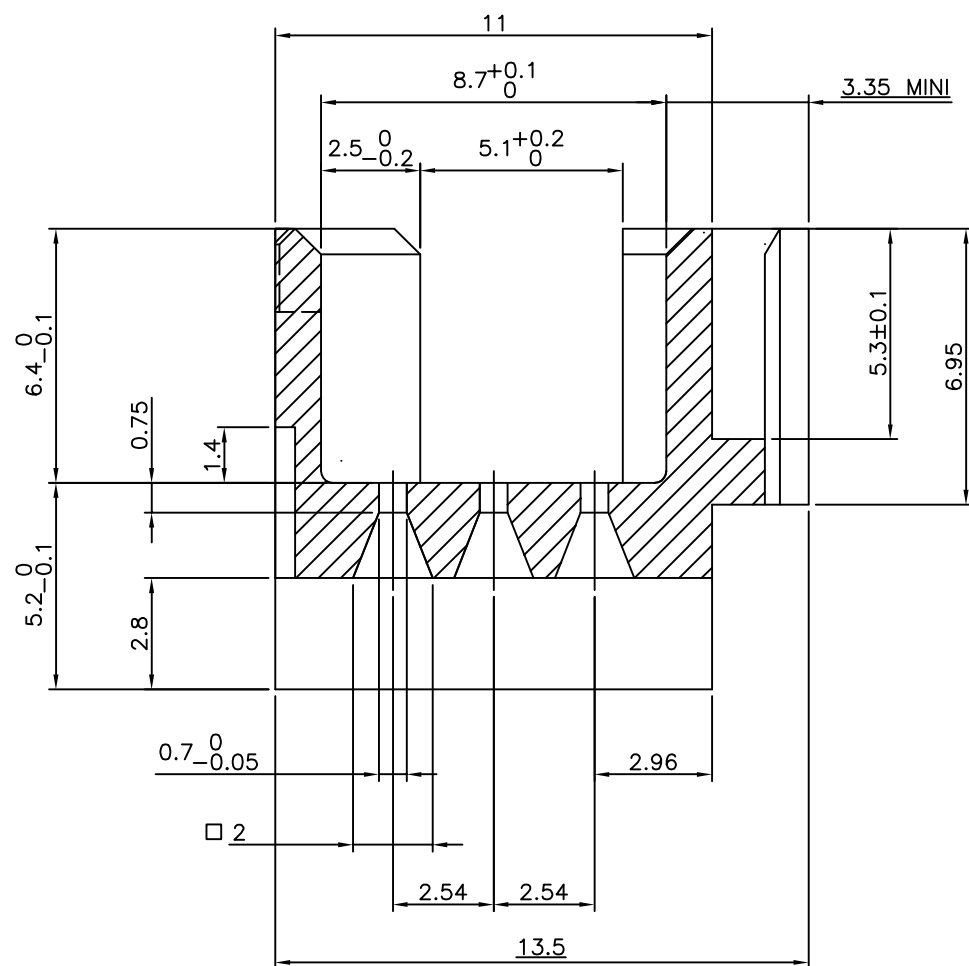

SECTION A-A
SCALE 8:1

NOTE: MATERIAL: UL94-VO, POLYESTER 30 % GLASS REINFORCED.

mat'l. code		surface		tolerance		projection		product family	
-		ISO 1302		ISO 406 ISO 1101				RPI	
ltr		ecn no		dr		date		title	
A		F10187		GCO		2001-04-10		RPI BODY	
B		I05-0123		MINI		2005-07-27		TE WITH LOCKING DEVICE	
C		I05-0248		MINI		2005-11-22			
D		I06-0115		MINI		2006-07-11			
sheet index		revision sheet		D		1			
								dwg no 54755 sheet 1 of 1 size A3 type Product Customer Drawing	



Copyright FCI