

A

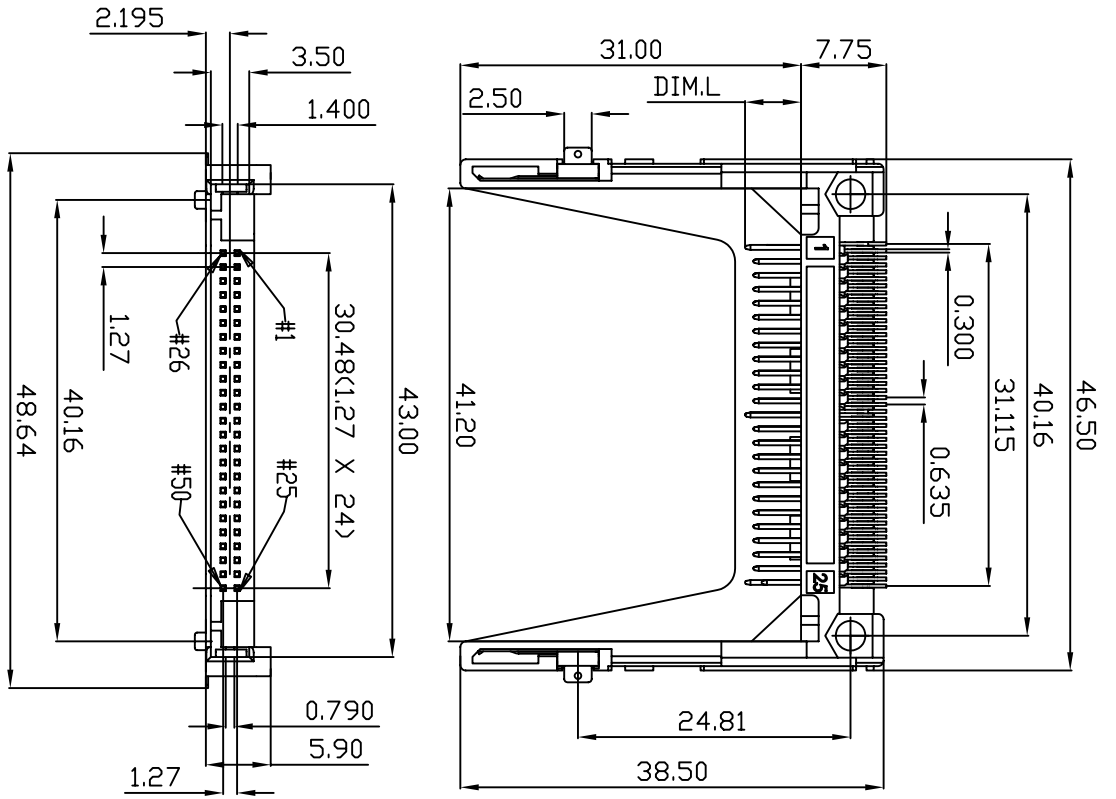

PIN NUMBER	DIM. L±0.10
25,26	3.50
ALL OTHER PINS	4.25
1, 13, 38, 50	5.00

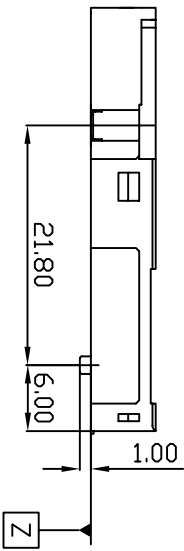

- NOTES :
1. MATERIAL : HIGH TEMPERATURE THERMOPLASTIC
INSULATOR : FLAMMABILITY RATING: UL94V-0
COLOR: IVORY
 2. PLATING : CONTACT : COPPER ALLOY
GROUND MOUNTING EAR: COPPER ALLOY
 3. SOLDER TAILS TO BE WITHIN 0.05 UPWARD AND 0.2 DOWNWARD FROM Z-DATUM PLACE, AND COPLANARITY OF SOLDER TAILS TO BE WITHIN 0.10mm.
 4. PRODUCT SPEC: GS-12-240.
 5. PACKAGING SPEC: GS-14-980.

mat'l. code		tolerances unless otherwise specified		CUSTOMER COPY		title	
ltr	ecn no	dr	ddte	lineor	projction	CF HDR TYPE II NORMAL	www.fciconnect.com
A	T04-0429	A.C.	12/16/04	.XX ±.20	MM	CF	
B	T05-0256	A.C.	11/09/05	.XXX ±.10		S/O=0.00mm	
C	T06-0172	A.C.	10/09/06	0° ±2°			
sheet	revision			engr	ALLEN CHANG	12/16/04	product family
index	sheet	1	2	chr	STERLING LIN	12/16/04	size/ dwg no
				appr	H.C LIU	12/16/04	CF
							code
							sheet
							1 of 2

ACAN

3

code code
22526

4

