



<b>Product Name:</b>	Pwrblade			
	Pwrblade			
<b>Product Manager:</b>	Henry Xie			
<b>Subject:</b>	Notification of Planned Change			
<b>Distribution:</b>	Active and Contract Customers of Pwrblade related business			
<b>Type of Change:</b>	Design Change			
<b>Change Description:</b>	<p>Subject: PwrBlade® Signal Contacts will move to Performance Based Plating and new Opposing Beams design (with new EON for press fit tail version) of Receptacle Signal Contact introduction.</p> <p>Nature of Change: With the continual escalation of gold and other precious metals, FCI will move to Performance Based Plating while continuing to meet the existing PwrBlade® product specification. This important move gives FCI the option to supply PwrBlade® products with either gold based plating or FCI's GXT™ palladium nickel alloy with gold flash plating on the Signal contacts of PwrBlade® connectors, for both the Header AND Receptacle signal contacts for all configurations (R/A header, vertical header, R/A receptacle and vertical receptacle). The end result allows FCI to maintain competitive pricing on PwrBlade® connectors with no change in performance to serve customers.</p> <p>In addition to the PwrBlade® product family signal contacts moving to performance based plating, FCI is also changing the signal contacts design in the receptacle connectors from the Hertz design into new Opposing Beams design with the purpose to better insure that the connectors mate optimally based on better positioning of the contacts. With this change a new EON design is applied together for press fit tail Receptacle signal contact accordingly. The Receptacle change will further insure that the same high performance that the PwrBlade® connector family has historically provided will continue into the future, this feature will be applied for all performance based plating versions of PwrBlade® receptacle connectors since this PCN effective date onwards. See attached file in the PCN package that illustrates the change of the receptacle signal contact.</p> <p>PwrBlade® header signal contact design remains not changing, only the plating is changing into performance based plating.</p> <p>FCI related customer prints are being updated to reflect Performance Based Plating rather than one plating type. FCI developed GXT in the 1980's and has used the plating on numerous connector families for over 25 years. Both gold and GXT plating variations have been fully tested to meet identical requirements. The product specification file and test report are attached for reference.</p> <p>The part numbers affective keeps no change for this PCN.</p> <p>Implementation Date: FCI may begin shipping PwrBlade® product with the GXT plated Signal contacts July 8th, 2013 or onwards. Please note that either gold based or GXT based signal contact products may ship depending upon price fluctuations in the precious metal markets from this date or onwards. FCI will begin shipping the Receptacle connectors with the new Opposing beams design signal contacts (and New EON for Press Fit tail version Receptacle) from this same date or onwards.</p> <p>Affected Part Numbers: See list attached, the affected P/Ns including, but not limited to these P/Ns in attached list with current marking, may including any more P/Ns that are to be created /active after release of this PCN. GXT plating options covers signal contacts of all PNs, new Opposing beams design feature change covers the signal contacts of all receptacle connectors only, new EON design covers press fit tail version of all receptacle connectors only.</p>			
	<b>Reason for Change:</b>	FCI to keep competitive for the Pwrblade connector business, avoid price up to customers during the recent fact of plating material cost remains high that with the trend to keep at high level in future.		
	<b>Affected Parts:</b>	see attached list		
	<b>Effective Date of Change:</b>	July	26	2013
	<b>Last Time Buy Date:</b>	N/A	N/A	N/A
<b>Last Disty Return Date:</b>	N/A	N/A	N/A	
<b>Last Time Shipment Date</b>	N/A	N/A	N/A	
<b>Datasheet Attached?</b>	Yes			
<b>Qual/Test Data Attached?</b>	Yes			
<b>Samples Availability Date:</b>	April	26	2013	
<b>Available Alternatives?</b>	No			
<b>Questions?</b>	Contact your local FCI Representative, , or Product Marketing Manager			
	Henry Xie / FCI DG Product Manager			
	Tel:86-769-88669255			
	Email: henry.xie@fci.com			

PCN	Item Number	Change	Effective Date	Last Time Buy Date	Last Disty return date	Replacement Part	Alternate Part	Comments
PCN13021	51219-XX001	DESIGN CHANGE	26-Jul-13					
PCN13021	51219-XX002	DESIGN CHANGE	26-Jul-13					
PCN13021	51219-XX002LF	DESIGN CHANGE	26-Jul-13					
PCN13021	51261-XX001	DESIGN CHANGE	26-Jul-13					
PCN13021	51261-XX001LF	DESIGN CHANGE	26-Jul-13					
PCN13021	51401-XX001	DESIGN CHANGE	26-Jul-13					
PCN13021	51401-XX002	DESIGN CHANGE	26-Jul-13					
PCN13021	51402-XX001	DESIGN CHANGE	26-Jul-13					
PCN13021	51402-XX001LF	DESIGN CHANGE	26-Jul-13					
PCN13021	51402-XX002	DESIGN CHANGE	26-Jul-13					
PCN13021	51402-XX002LF	DESIGN CHANGE	26-Jul-13					
PCN13021	51413-XX001	DESIGN CHANGE	26-Jul-13					
PCN13021	51413-XX001LF	DESIGN CHANGE	26-Jul-13					
PCN13021	51415-001	DESIGN CHANGE	26-Jul-13					
PCN13021	51415-001LF	DESIGN CHANGE	26-Jul-13					
PCN13021	51415-002	DESIGN CHANGE	26-Jul-13					
PCN13021	51415-002LF	DESIGN CHANGE	26-Jul-13					
PCN13021	51415-003	DESIGN CHANGE	26-Jul-13					
PCN13021	51415-004	DESIGN CHANGE	26-Jul-13					
PCN13021	51415-005	DESIGN CHANGE	26-Jul-13					
PCN13021	51415-005LF	DESIGN CHANGE	26-Jul-13					
PCN13021	51415-006LF	DESIGN CHANGE	26-Jul-13					
PCN13021	51416-001	DESIGN CHANGE	26-Jul-13					
PCN13021	51416-001GLF	DESIGN CHANGE	26-Jul-13					
PCN13021	51416-001LF	DESIGN CHANGE	26-Jul-13					
PCN13021	51416-002	DESIGN CHANGE	26-Jul-13					
PCN13021	51416-002LF	DESIGN CHANGE	26-Jul-13					
PCN13021	51416-003	DESIGN CHANGE	26-Jul-13					
PCN13021	51416-003LF	DESIGN CHANGE	26-Jul-13					
PCN13021	51416-004LF	DESIGN CHANGE	26-Jul-13					
PCN13021	51419-XX001	DESIGN CHANGE	26-Jul-13					
PCN13021	51419-XX001LF	DESIGN CHANGE	26-Jul-13					
PCN13021	51425-001	DESIGN CHANGE	26-Jul-13					
PCN13021	51425-001LF	DESIGN CHANGE	26-Jul-13					
PCN13021	51425-002	DESIGN CHANGE	26-Jul-13					
PCN13021	51425-002LF	DESIGN CHANGE	26-Jul-13					
PCN13021	51425-003	DESIGN CHANGE	26-Jul-13					
PCN13021	51426-001	DESIGN CHANGE	26-Jul-13					
PCN13021	51426-001LF	DESIGN CHANGE	26-Jul-13					
PCN13021	51427-001	DESIGN CHANGE	26-Jul-13					

PCN13021	51427-001LF	DESIGN CHANGE	26-Jul-13
PCN13021	51484-XX001	DESIGN CHANGE	26-Jul-13
PCN13021	51484-XX002	DESIGN CHANGE	26-Jul-13
PCN13021	51516-001	DESIGN CHANGE	26-Jul-13
PCN13021	51517-001	DESIGN CHANGE	26-Jul-13
PCN13021	51520-001	DESIGN CHANGE	26-Jul-13
PCN13021	51521-001	DESIGN CHANGE	26-Jul-13
PCN13021	51526-XX001	DESIGN CHANGE	26-Jul-13
PCN13021	51530-XX001	DESIGN CHANGE	26-Jul-13
PCN13021	51534-XX001	DESIGN CHANGE	26-Jul-13
PCN13021	51534-XX001LF	DESIGN CHANGE	26-Jul-13
PCN13021	51534-XX002	DESIGN CHANGE	26-Jul-13
PCN13021	51535-XX001	DESIGN CHANGE	26-Jul-13
PCN13021	51535-XX001LF	DESIGN CHANGE	26-Jul-13
PCN13021	51601-XX001	DESIGN CHANGE	26-Jul-13
PCN13021	51602-XX001	DESIGN CHANGE	26-Jul-13
PCN13021	51617-XX002LF	DESIGN CHANGE	26-Jul-13
PCN13021	51624-XX001	DESIGN CHANGE	26-Jul-13
PCN13021	51624-XX001LF	DESIGN CHANGE	26-Jul-13
PCN13021	51624-XX002	DESIGN CHANGE	26-Jul-13
PCN13021	51624-XX002LF	DESIGN CHANGE	26-Jul-13
PCN13021	51624-XX003	DESIGN CHANGE	26-Jul-13
PCN13021	51624-XX003LF	DESIGN CHANGE	26-Jul-13
PCN13021	51624-XX004	DESIGN CHANGE	26-Jul-13
PCN13021	51624-XX005LF	DESIGN CHANGE	26-Jul-13
PCN13021	51624-XX006LF	DESIGN CHANGE	26-Jul-13
PCN13021	51625-XX001	DESIGN CHANGE	26-Jul-13
PCN13021	51625-XX001LF	DESIGN CHANGE	26-Jul-13
PCN13021	51625-XX002	DESIGN CHANGE	26-Jul-13
PCN13021	51625-XX002LF	DESIGN CHANGE	26-Jul-13
PCN13021	51625-XX003	DESIGN CHANGE	26-Jul-13
PCN13021	51625-XX003LF	DESIGN CHANGE	26-Jul-13
PCN13021	51625-XX004LF	DESIGN CHANGE	26-Jul-13
PCN13021	51626-001	DESIGN CHANGE	26-Jul-13
PCN13021	51627-001	DESIGN CHANGE	26-Jul-13
PCN13021	51627-001LF	DESIGN CHANGE	26-Jul-13
PCN13021	51627-002	DESIGN CHANGE	26-Jul-13
PCN13021	51627-002LF	DESIGN CHANGE	26-Jul-13
PCN13021	51632-001	DESIGN CHANGE	26-Jul-13
PCN13021	51632-002	DESIGN CHANGE	26-Jul-13
PCN13021	51633-001	DESIGN CHANGE	26-Jul-13

PCN13021	51649-001	DESIGN CHANGE	26-Jul-13
PCN13021	51651-001	DESIGN CHANGE	26-Jul-13
PCN13021	51652-001	DESIGN CHANGE	26-Jul-13
PCN13021	51655-001	DESIGN CHANGE	26-Jul-13
PCN13021	51657-001	DESIGN CHANGE	26-Jul-13
PCN13021	51657-001LF	DESIGN CHANGE	26-Jul-13
PCN13021	51658-001	DESIGN CHANGE	26-Jul-13
PCN13021	51658-001LF	DESIGN CHANGE	26-Jul-13
PCN13021	51659-001	DESIGN CHANGE	26-Jul-13
PCN13021	51659-001LF	DESIGN CHANGE	26-Jul-13
PCN13021	51666-001	DESIGN CHANGE	26-Jul-13
PCN13021	51666-001LF	DESIGN CHANGE	26-Jul-13
PCN13021	51667-XX001	DESIGN CHANGE	26-Jul-13
PCN13021	51667-XX001LF	DESIGN CHANGE	26-Jul-13
PCN13021	51668-001	DESIGN CHANGE	26-Jul-13
PCN13021	51668-001LF	DESIGN CHANGE	26-Jul-13
PCN13021	51669-001	DESIGN CHANGE	26-Jul-13
PCN13021	51670-001	DESIGN CHANGE	26-Jul-13
PCN13021	51671-001	DESIGN CHANGE	26-Jul-13
PCN13021	51672-001	DESIGN CHANGE	26-Jul-13
PCN13021	51672-001LF	DESIGN CHANGE	26-Jul-13
PCN13021	51672-002	DESIGN CHANGE	26-Jul-13
PCN13021	51673-001	DESIGN CHANGE	26-Jul-13
PCN13021	51673-001LF	DESIGN CHANGE	26-Jul-13
PCN13021	51679-001	DESIGN CHANGE	26-Jul-13
PCN13021	51680-001	DESIGN CHANGE	26-Jul-13
PCN13021	51683-001	DESIGN CHANGE	26-Jul-13
PCN13021	51683-001LF	DESIGN CHANGE	26-Jul-13
PCN13021	51684-001	DESIGN CHANGE	26-Jul-13
PCN13021	51684-001LF	DESIGN CHANGE	26-Jul-13
PCN13021	51685-001	DESIGN CHANGE	26-Jul-13
PCN13021	51691-001	DESIGN CHANGE	26-Jul-13
PCN13021	51691-001LF	DESIGN CHANGE	26-Jul-13
PCN13021	51693-001	DESIGN CHANGE	26-Jul-13
PCN13021	51694-001	DESIGN CHANGE	26-Jul-13
PCN13021	51694-002	DESIGN CHANGE	26-Jul-13
PCN13021	51694-002LF	DESIGN CHANGE	26-Jul-13
PCN13021	51694-003	DESIGN CHANGE	26-Jul-13
PCN13021	51694-003LF	DESIGN CHANGE	26-Jul-13
PCN13021	51694-004	DESIGN CHANGE	26-Jul-13
PCN13021	51694-004LF	DESIGN CHANGE	26-Jul-13

PCN13021	51694-005	DESIGN CHANGE	26-Jul-13
PCN13021	51694-006	DESIGN CHANGE	26-Jul-13
PCN13021	51700-10002406AA	DESIGN CHANGE	26-Jul-13
PCN13021	51700-10100401AALF	DESIGN CHANGE	26-Jul-13
PCN13021	51700-10100801AA	DESIGN CHANGE	26-Jul-13
PCN13021	51700-10100801AALF	DESIGN CHANGE	26-Jul-13
PCN13021	51700-10100801CALF	DESIGN CHANGE	26-Jul-13
PCN13021	51700-10100801CCLF	DESIGN CHANGE	26-Jul-13
PCN13021	51700-10101201AALF	DESIGN CHANGE	26-Jul-13
PCN13021	51700-10101201AC	DESIGN CHANGE	26-Jul-13
PCN13021	51700-10101201ACLF	DESIGN CHANGE	26-Jul-13
PCN13021	51700-10101201CALF	DESIGN CHANGE	26-Jul-13
PCN13021	51700-10101201CC	DESIGN CHANGE	26-Jul-13
PCN13021	51700-10101201CCLF	DESIGN CHANGE	26-Jul-13
PCN13021	51700-10101601AALF	DESIGN CHANGE	26-Jul-13
PCN13021	51700-10102001AALF	DESIGN CHANGE	26-Jul-13
PCN13021	51700-10102001CA	DESIGN CHANGE	26-Jul-13
PCN13021	51700-10102001CCLF	DESIGN CHANGE	26-Jul-13
PCN13021	51700-10102401AA	DESIGN CHANGE	26-Jul-13
PCN13021	51700-10102401AALF	DESIGN CHANGE	26-Jul-13
PCN13021	51700-10102401ACLF	DESIGN CHANGE	26-Jul-13
PCN13021	51700-10102401CALF	DESIGN CHANGE	26-Jul-13
PCN13021	51700-10102401CC	DESIGN CHANGE	26-Jul-13
PCN13021	51700-10102801CC	DESIGN CHANGE	26-Jul-13
PCN13021	51700-10103201AALF	DESIGN CHANGE	26-Jul-13
PCN13021	51700-10103201CCLF	DESIGN CHANGE	26-Jul-13
PCN13021	51700-10104801AA	DESIGN CHANGE	26-Jul-13
PCN13021	51700-10104801AALF	DESIGN CHANGE	26-Jul-13
PCN13021	51700-10106001AA	DESIGN CHANGE	26-Jul-13
PCN13021	51700-10106001AALF	DESIGN CHANGE	26-Jul-13
PCN13021	51700-10106001CC	DESIGN CHANGE	26-Jul-13
PCN13021	51700-10110001AALF	DESIGN CHANGE	26-Jul-13
PCN13021	51700-10112801AALF	DESIGN CHANGE	26-Jul-13
PCN13021	51700-10114801AA	DESIGN CHANGE	26-Jul-13
PCN13021	51700-10114801AALF	DESIGN CHANGE	26-Jul-13
PCN13021	51700-10200402AALF	DESIGN CHANGE	26-Jul-13
PCN13021	51700-10200402BA	DESIGN CHANGE	26-Jul-13
PCN13021	51700-10200402BALF	DESIGN CHANGE	26-Jul-13
PCN13021	51700-10200402CA	DESIGN CHANGE	26-Jul-13
PCN13021	51700-10200802CALF	DESIGN CHANGE	26-Jul-13
PCN13021	51700-10201202AA	DESIGN CHANGE	26-Jul-13

PCN13021	51700-10201202AALF	DESIGN CHANGE	26-Jul-13
PCN13021	51700-10201202BALF	DESIGN CHANGE	26-Jul-13
PCN13021	51700-10201202CALF	DESIGN CHANGE	26-Jul-13
PCN13021	51700-10201202CC	DESIGN CHANGE	26-Jul-13
PCN13021	51700-10201202CCLF	DESIGN CHANGE	26-Jul-13
PCN13021	51700-10201602AA	DESIGN CHANGE	26-Jul-13
PCN13021	51700-10201602AALF	DESIGN CHANGE	26-Jul-13
PCN13021	51700-10201602CALF	DESIGN CHANGE	26-Jul-13
PCN13021	51700-10201602CC	DESIGN CHANGE	26-Jul-13
PCN13021	51700-10201602CCLF	DESIGN CHANGE	26-Jul-13
PCN13021	51700-10202002AALF	DESIGN CHANGE	26-Jul-13
PCN13021	51700-10202401CC	DESIGN CHANGE	26-Jul-13
PCN13021	51700-10202402AA	DESIGN CHANGE	26-Jul-13
PCN13021	51700-10202402AALF	DESIGN CHANGE	26-Jul-13
PCN13021	51700-10202402BALF	DESIGN CHANGE	26-Jul-13
PCN13021	51700-10202402CA	DESIGN CHANGE	26-Jul-13
PCN13021	51700-10202402CALF	DESIGN CHANGE	26-Jul-13
PCN13021	51700-10202402CC	DESIGN CHANGE	26-Jul-13
PCN13021	51700-10202402CCLF	DESIGN CHANGE	26-Jul-13
PCN13021	51700-10203202CC	DESIGN CHANGE	26-Jul-13
PCN13021	51700-10203202CCLF	DESIGN CHANGE	26-Jul-13
PCN13021	51700-10204002AALF	DESIGN CHANGE	26-Jul-13
PCN13021	51700-10204802AALF	DESIGN CHANGE	26-Jul-13
PCN13021	51700-10204802AC	DESIGN CHANGE	26-Jul-13
PCN13021	51700-10206002AALF	DESIGN CHANGE	26-Jul-13
PCN13021	51700-10208002AA	DESIGN CHANGE	26-Jul-13
PCN13021	51700-10208002AALF	DESIGN CHANGE	26-Jul-13
PCN13021	51700-10209602AALF	DESIGN CHANGE	26-Jul-13
PCN13021	51700-10300403AALF	DESIGN CHANGE	26-Jul-13
PCN13021	51700-10301202AALF	DESIGN CHANGE	26-Jul-13
PCN13021	51700-10301203AA	DESIGN CHANGE	26-Jul-13
PCN13021	51700-10301203AALF	DESIGN CHANGE	26-Jul-13
PCN13021	51700-10301203CC	DESIGN CHANGE	26-Jul-13
PCN13021	51700-10301603AALF	DESIGN CHANGE	26-Jul-13
PCN13021	51700-10302403AA	DESIGN CHANGE	26-Jul-13
PCN13021	51700-10302403AALF	DESIGN CHANGE	26-Jul-13
PCN13021	51700-10302403CALF	DESIGN CHANGE	26-Jul-13
PCN13021	51700-10302403CC	DESIGN CHANGE	26-Jul-13
PCN13021	51700-10302403CCLF	DESIGN CHANGE	26-Jul-13
PCN13021	51700-10302404AA	DESIGN CHANGE	26-Jul-13
PCN13021	51700-10302801CC	DESIGN CHANGE	26-Jul-13

PCN13021	51700-10303203ACLF	DESIGN CHANGE	26-Jul-13
PCN13021	51700-10304003AALF	DESIGN CHANGE	26-Jul-13
PCN13021	51700-10304803AALF	DESIGN CHANGE	26-Jul-13
PCN13021	51700-10400404AALF	DESIGN CHANGE	26-Jul-13
PCN13021	51700-10400804AALF	DESIGN CHANGE	26-Jul-13
PCN13021	51700-10400804CALF	DESIGN CHANGE	26-Jul-13
PCN13021	51700-10401202AALF	DESIGN CHANGE	26-Jul-13
PCN13021	51700-10401204CA	DESIGN CHANGE	26-Jul-13
PCN13021	51700-10401204CALF	DESIGN CHANGE	26-Jul-13
PCN13021	51700-10401603CALF	DESIGN CHANGE	26-Jul-13
PCN13021	51700-10401604CCLF	DESIGN CHANGE	26-Jul-13
PCN13021	51700-10402402AA	DESIGN CHANGE	26-Jul-13
PCN13021	51700-10402402CCLF	DESIGN CHANGE	26-Jul-13
PCN13021	51700-10402404AA	DESIGN CHANGE	26-Jul-13
PCN13021	51700-10402404AALF	DESIGN CHANGE	26-Jul-13
PCN13021	51700-10402404ACLF	DESIGN CHANGE	26-Jul-13
PCN13021	51700-10402404CALF	DESIGN CHANGE	26-Jul-13
PCN13021	51700-10402404CC	DESIGN CHANGE	26-Jul-13
PCN13021	51700-10402404CCLF	DESIGN CHANGE	26-Jul-13
PCN13021	51700-10402405AALF	DESIGN CHANGE	26-Jul-13
PCN13021	51700-10402804AALF	DESIGN CHANGE	26-Jul-13
PCN13021	51700-10402804CA	DESIGN CHANGE	26-Jul-13
PCN13021	51700-10403204AALF	DESIGN CHANGE	26-Jul-13
PCN13021	51700-10403204CA	DESIGN CHANGE	26-Jul-13
PCN13021	51700-10403204CALF	DESIGN CHANGE	26-Jul-13
PCN13021	51700-10403607AALF	DESIGN CHANGE	26-Jul-13
PCN13021	51700-10404004AA	DESIGN CHANGE	26-Jul-13
PCN13021	51700-10404004CC	DESIGN CHANGE	26-Jul-13
PCN13021	51700-10404804AA	DESIGN CHANGE	26-Jul-13
PCN13021	51700-10405604CCLF	DESIGN CHANGE	26-Jul-13
PCN13021	51700-10412004AALF	DESIGN CHANGE	26-Jul-13
PCN13021	51700-10500805CALF	DESIGN CHANGE	26-Jul-13
PCN13021	51700-10502405AA	DESIGN CHANGE	26-Jul-13
PCN13021	51700-10502405AALF	DESIGN CHANGE	26-Jul-13
PCN13021	51700-10502805CA	DESIGN CHANGE	26-Jul-13
PCN13021	51700-10503605CC	DESIGN CHANGE	26-Jul-13
PCN13021	51700-10600806CALF	DESIGN CHANGE	26-Jul-13
PCN13021	51700-10602004AA	DESIGN CHANGE	26-Jul-13
PCN13021	51700-10602004CC	DESIGN CHANGE	26-Jul-13
PCN13021	51700-10602406AALF	DESIGN CHANGE	26-Jul-13
PCN13021	51700-10602406CA	DESIGN CHANGE	26-Jul-13

PCN13021	51700-10602406CALF	DESIGN CHANGE	26-Jul-13
PCN13021	51700-10602806AC	DESIGN CHANGE	26-Jul-13
PCN13021	51700-10602806CA	DESIGN CHANGE	26-Jul-13
PCN13021	51700-10606006AA	DESIGN CHANGE	26-Jul-13
PCN13021	51700-10606006AALF	DESIGN CHANGE	26-Jul-13
PCN13021	51700-10701607AA	DESIGN CHANGE	26-Jul-13
PCN13021	51700-10703207ACLF	DESIGN CHANGE	26-Jul-13
PCN13021	51700-10703207CCLF	DESIGN CHANGE	26-Jul-13
PCN13021	51700-10801208CC	DESIGN CHANGE	26-Jul-13
PCN13021	51700-10801208CCLF	DESIGN CHANGE	26-Jul-13
PCN13021	51700-10801608AALF	DESIGN CHANGE	26-Jul-13
PCN13021	51700-10802408CALF	DESIGN CHANGE	26-Jul-13
PCN13021	51700-10810008CA	DESIGN CHANGE	26-Jul-13
PCN13021	51700-10810008CALF	DESIGN CHANGE	26-Jul-13
PCN13021	51700-11004410CCLF	DESIGN CHANGE	26-Jul-13
PCN13021	51700-11008410AA	DESIGN CHANGE	26-Jul-13
PCN13021	51700-11008410AALF	DESIGN CHANGE	26-Jul-13
PCN13021	51700-11102003AA	DESIGN CHANGE	26-Jul-13
PCN13021	51700-11102003AALF	DESIGN CHANGE	26-Jul-13
PCN13021	51700-11102003CALF	DESIGN CHANGE	26-Jul-13
PCN13021	51700-11102003CC	DESIGN CHANGE	26-Jul-13
PCN13021	51700-11102003CCLF	DESIGN CHANGE	26-Jul-13
PCN13021	51701-10000404AA	DESIGN CHANGE	26-Jul-13
PCN13021	51701-10000404AALF	DESIGN CHANGE	26-Jul-13
PCN13021	51701-10000803AALF	DESIGN CHANGE	26-Jul-13
PCN13021	51701-10000804AA	DESIGN CHANGE	26-Jul-13
PCN13021	51701-10000804AALF	DESIGN CHANGE	26-Jul-13
PCN13021	51701-10000804CALF	DESIGN CHANGE	26-Jul-13
PCN13021	51701-10000810CC	DESIGN CHANGE	26-Jul-13
PCN13021	51701-10001202CCLF	DESIGN CHANGE	26-Jul-13
PCN13021	51701-10001204AALF	DESIGN CHANGE	26-Jul-13
PCN13021	51701-10001204CALF	DESIGN CHANGE	26-Jul-13
PCN13021	51701-10001204CCLF	DESIGN CHANGE	26-Jul-13
PCN13021	51701-10001602AALF	DESIGN CHANGE	26-Jul-13
PCN13021	51701-10001604AALF	DESIGN CHANGE	26-Jul-13
PCN13021	51701-10001605AALF	DESIGN CHANGE	26-Jul-13
PCN13021	51701-10002002CCLF	DESIGN CHANGE	26-Jul-13
PCN13021	51701-10002004BCLF	DESIGN CHANGE	26-Jul-13
PCN13021	51701-10002004CCLF	DESIGN CHANGE	26-Jul-13
PCN13021	51701-10002014BALF	DESIGN CHANGE	26-Jul-13
PCN13021	51701-10002402CALF	DESIGN CHANGE	26-Jul-13



PCN13021	51701-10002404AALF	DESIGN CHANGE	26-Jul-13
PCN13021	51701-10002406AA	DESIGN CHANGE	26-Jul-13
PCN13021	51701-10002406AALF	DESIGN CHANGE	26-Jul-13
PCN13021	51701-10002406ACLF	DESIGN CHANGE	26-Jul-13
PCN13021	51701-10002406CALF	DESIGN CHANGE	26-Jul-13
PCN13021	51701-10002406CCLF	DESIGN CHANGE	26-Jul-13
PCN13021	51701-10002408AA	DESIGN CHANGE	26-Jul-13
PCN13021	51701-10002408AALF	DESIGN CHANGE	26-Jul-13
PCN13021	51701-10002408BCLF	DESIGN CHANGE	26-Jul-13
PCN13021	51701-10002408CC	DESIGN CHANGE	26-Jul-13
PCN13021	51701-10002408CCLF	DESIGN CHANGE	26-Jul-13
PCN13021	51701-10002410CC	DESIGN CHANGE	26-Jul-13
PCN13021	51701-10002414AA	DESIGN CHANGE	26-Jul-13
PCN13021	51701-10002414AALF	DESIGN CHANGE	26-Jul-13
PCN13021	51701-10002416AALF	DESIGN CHANGE	26-Jul-13
PCN13021	51701-10002804AALF	DESIGN CHANGE	26-Jul-13
PCN13021	51701-10002806ACLF	DESIGN CHANGE	26-Jul-13
PCN13021	51701-10002806CCLF	DESIGN CHANGE	26-Jul-13
PCN13021	51701-10002812AA	DESIGN CHANGE	26-Jul-13
PCN13021	51701-10002812CC	DESIGN CHANGE	26-Jul-13
PCN13021	51701-10003204AALF	DESIGN CHANGE	26-Jul-13
PCN13021	51701-10003204CCLF	DESIGN CHANGE	26-Jul-13
PCN13021	51701-10003208BA	DESIGN CHANGE	26-Jul-13
PCN13021	51701-10003208BC	DESIGN CHANGE	26-Jul-13
PCN13021	51701-10003208CC	DESIGN CHANGE	26-Jul-13
PCN13021	51701-10003208CCLF	DESIGN CHANGE	26-Jul-13
PCN13021	51701-10003212AALF	DESIGN CHANGE	26-Jul-13
PCN13021	51701-10003214AALF	DESIGN CHANGE	26-Jul-13
PCN13021	51701-10004007ACLF	DESIGN CHANGE	26-Jul-13
PCN13021	51701-10004010CCLF	DESIGN CHANGE	26-Jul-13
PCN13021	51701-10004818AALF	DESIGN CHANGE	26-Jul-13
PCN13021	51701-10004818CCLF	DESIGN CHANGE	26-Jul-13
PCN13021	51701-10005611CCLF	DESIGN CHANGE	26-Jul-13
PCN13021	51701-10006003AA	DESIGN CHANGE	26-Jul-13
PCN13021	51701-10006408CC	DESIGN CHANGE	26-Jul-13
PCN13021	51701-10006408CCLF	DESIGN CHANGE	26-Jul-13
PCN13021	51701-10006411CCLF	DESIGN CHANGE	26-Jul-13
PCN13021	51701-10009202CC	DESIGN CHANGE	26-Jul-13
PCN13021	51701-10012002CALF	DESIGN CHANGE	26-Jul-13
PCN13021	51701-10013602CCLF	DESIGN CHANGE	26-Jul-13
PCN13021	51702-10101600CA	DESIGN CHANGE	26-Jul-13

PCN13021	51702-10103600AALF	DESIGN CHANGE	26-Jul-13
PCN13021	51702-10200400AALF	DESIGN CHANGE	26-Jul-13
PCN13021	51702-10200800AALF	DESIGN CHANGE	26-Jul-13
PCN13021	51702-10200800CCLF	DESIGN CHANGE	26-Jul-13
PCN13021	51702-10201200AA	DESIGN CHANGE	26-Jul-13
PCN13021	51702-10201200AALF	DESIGN CHANGE	26-Jul-13
PCN13021	51702-10201200CCLF	DESIGN CHANGE	26-Jul-13
PCN13021	51702-10201600AALF	DESIGN CHANGE	26-Jul-13
PCN13021	51702-10201600CCLF	DESIGN CHANGE	26-Jul-13
PCN13021	51702-10202400AA	DESIGN CHANGE	26-Jul-13
PCN13021	51702-10202400CC	DESIGN CHANGE	26-Jul-13
PCN13021	51702-10202800CCLF	DESIGN CHANGE	26-Jul-13
PCN13021	51702-10203600CC	DESIGN CHANGE	26-Jul-13
PCN13021	51702-10204000AA	DESIGN CHANGE	26-Jul-13
PCN13021	51702-10204800CC	DESIGN CHANGE	26-Jul-13
PCN13021	51702-10301600AALF	DESIGN CHANGE	26-Jul-13
PCN13021	51702-10400400CC	DESIGN CHANGE	26-Jul-13
PCN13021	51702-10401200CCLF	DESIGN CHANGE	26-Jul-13
PCN13021	51702-10401600AALF	DESIGN CHANGE	26-Jul-13
PCN13021	51702-10401600CCLF	DESIGN CHANGE	26-Jul-13
PCN13021	51702-10402000AALF	DESIGN CHANGE	26-Jul-13
PCN13021	51702-10402000CCLF	DESIGN CHANGE	26-Jul-13
PCN13021	51702-10402400AALF	DESIGN CHANGE	26-Jul-13
PCN13021	51702-10402400CCLF	DESIGN CHANGE	26-Jul-13
PCN13021	51702-10403200AA	DESIGN CHANGE	26-Jul-13
PCN13021	51702-10403200AALF	DESIGN CHANGE	26-Jul-13
PCN13021	51702-10407200CCLF	DESIGN CHANGE	26-Jul-13
PCN13021	51702-10502400CCLF	DESIGN CHANGE	26-Jul-13
PCN13021	51702-10600800AALF	DESIGN CHANGE	26-Jul-13
PCN13021	51702-10600800CCLF	DESIGN CHANGE	26-Jul-13
PCN13021	51702-10601600CALF	DESIGN CHANGE	26-Jul-13
PCN13021	51702-10602000AALF	DESIGN CHANGE	26-Jul-13
PCN13021	51702-10602400BALF	DESIGN CHANGE	26-Jul-13
PCN13021	51702-10602400CCLF	DESIGN CHANGE	26-Jul-13
PCN13021	51702-10603600AALF	DESIGN CHANGE	26-Jul-13
PCN13021	51702-10704000ACLF	DESIGN CHANGE	26-Jul-13
PCN13021	51702-10800800AALF	DESIGN CHANGE	26-Jul-13
PCN13021	51702-10801600CC	DESIGN CHANGE	26-Jul-13
PCN13021	51702-10801600CCLF	DESIGN CHANGE	26-Jul-13
PCN13021	51702-10802400BA	DESIGN CHANGE	26-Jul-13
PCN13021	51702-10802400CC	DESIGN CHANGE	26-Jul-13

PCN13021	51702-10802400CCLF	DESIGN CHANGE	26-Jul-13
PCN13021	51702-10802800CALF	DESIGN CHANGE	26-Jul-13
PCN13021	51702-10803200CC	DESIGN CHANGE	26-Jul-13
PCN13021	51702-10804400AALF	DESIGN CHANGE	26-Jul-13
PCN13021	51702-11003200CCLF	DESIGN CHANGE	26-Jul-13
PCN13021	51702-11102400AALF	DESIGN CHANGE	26-Jul-13
PCN13021	51702-11102400CCLF	DESIGN CHANGE	26-Jul-13
PCN13021	51702-11106400CCLF	DESIGN CHANGE	26-Jul-13
PCN13021	51702-11200800AA	DESIGN CHANGE	26-Jul-13
PCN13021	51702-11201200AA	DESIGN CHANGE	26-Jul-13
PCN13021	51702-11201200AALF	DESIGN CHANGE	26-Jul-13
PCN13021	51702-11202000AALF	DESIGN CHANGE	26-Jul-13
PCN13021	51702-11202000CCLF	DESIGN CHANGE	26-Jul-13
PCN13021	51702-11402400AALF	DESIGN CHANGE	26-Jul-13
PCN13021	51702-11402400CCLF	DESIGN CHANGE	26-Jul-13
PCN13021	51702-11804400AALF	DESIGN CHANGE	26-Jul-13
PCN13021	51704-10014804A0	DESIGN CHANGE	26-Jul-13
PCN13021	51704-10202402A0	DESIGN CHANGE	26-Jul-13
PCN13021	51704-10202402AOLF	DESIGN CHANGE	26-Jul-13
PCN13021	51704-10206002A0	DESIGN CHANGE	26-Jul-13
PCN13021	51704-10206002AOLF	DESIGN CHANGE	26-Jul-13
PCN13021	51704-10301203COLF	DESIGN CHANGE	26-Jul-13
PCN13021	51704-10301603C0	DESIGN CHANGE	26-Jul-13
PCN13021	51704-10302403C0	DESIGN CHANGE	26-Jul-13
PCN13021	51704-10302403COLF	DESIGN CHANGE	26-Jul-13
PCN13021	51704-10302803C0	DESIGN CHANGE	26-Jul-13
PCN13021	51704-10401204BOLF	DESIGN CHANGE	26-Jul-13
PCN13021	51704-10402404C0	DESIGN CHANGE	26-Jul-13
PCN13021	51704-11001210BOLF	DESIGN CHANGE	26-Jul-13
PCN13021	51705-10001620B0	DESIGN CHANGE	26-Jul-13
PCN13021	51705-10002006AOLF	DESIGN CHANGE	26-Jul-13
PCN13021	51705-10002403C0	DESIGN CHANGE	26-Jul-13
PCN13021	51705-10002406AOLF	DESIGN CHANGE	26-Jul-13
PCN13021	51705-10014804A0	DESIGN CHANGE	26-Jul-13
PCN13021	51705-10014804B0	DESIGN CHANGE	26-Jul-13
PCN13021	51706-10200800AOLF	DESIGN CHANGE	26-Jul-13
PCN13021	51706-10207200AOLF	DESIGN CHANGE	26-Jul-13
PCN13021	51706-10402400B0	DESIGN CHANGE	26-Jul-13
PCN13021	51706-10402400BOLF	DESIGN CHANGE	26-Jul-13
PCN13021	51706-10402400C0	DESIGN CHANGE	26-Jul-13
PCN13021	51706-10402400COLF	DESIGN CHANGE	26-Jul-13

PCN13021	51706-10502400A0	DESIGN CHANGE	26-Jul-13
PCN13021	51706-10602000A0LF	DESIGN CHANGE	26-Jul-13
PCN13021	51710-001	DESIGN CHANGE	26-Jul-13
PCN13021	51710-002	DESIGN CHANGE	26-Jul-13
PCN13021	51710-003	DESIGN CHANGE	26-Jul-13
PCN13021	51710-004	DESIGN CHANGE	26-Jul-13
PCN13021	51710-005	DESIGN CHANGE	26-Jul-13
PCN13021	51710-006	DESIGN CHANGE	26-Jul-13
PCN13021	51710-007	DESIGN CHANGE	26-Jul-13
PCN13021	51710-008	DESIGN CHANGE	26-Jul-13
PCN13021	51710-008LF	DESIGN CHANGE	26-Jul-13
PCN13021	51710-009	DESIGN CHANGE	26-Jul-13
PCN13021	51710-010	DESIGN CHANGE	26-Jul-13
PCN13021	51710-010LF	DESIGN CHANGE	26-Jul-13
PCN13021	51710-011	DESIGN CHANGE	26-Jul-13
PCN13021	51710-012	DESIGN CHANGE	26-Jul-13
PCN13021	51710-012LF	DESIGN CHANGE	26-Jul-13
PCN13021	51710-013	DESIGN CHANGE	26-Jul-13
PCN13021	51710-014	DESIGN CHANGE	26-Jul-13
PCN13021	51710-014LF	DESIGN CHANGE	26-Jul-13
PCN13021	51710-015	DESIGN CHANGE	26-Jul-13
PCN13021	51710-015LF	DESIGN CHANGE	26-Jul-13
PCN13021	51710-016	DESIGN CHANGE	26-Jul-13
PCN13021	51710-016LF	DESIGN CHANGE	26-Jul-13
PCN13021	51710-017	DESIGN CHANGE	26-Jul-13
PCN13021	51710-017LF	DESIGN CHANGE	26-Jul-13
PCN13021	51710-018LF	DESIGN CHANGE	26-Jul-13
PCN13021	51710-019	DESIGN CHANGE	26-Jul-13
PCN13021	51710-019LF	DESIGN CHANGE	26-Jul-13
PCN13021	51710-020LF	DESIGN CHANGE	26-Jul-13
PCN13021	51710-021LF	DESIGN CHANGE	26-Jul-13
PCN13021	51710-022	DESIGN CHANGE	26-Jul-13
PCN13021	51710-022LF	DESIGN CHANGE	26-Jul-13
PCN13021	51710-023	DESIGN CHANGE	26-Jul-13
PCN13021	51710-023LF	DESIGN CHANGE	26-Jul-13
PCN13021	51710-024	DESIGN CHANGE	26-Jul-13
PCN13021	51710-024LF	DESIGN CHANGE	26-Jul-13
PCN13021	51710-025	DESIGN CHANGE	26-Jul-13
PCN13021	51710-026	DESIGN CHANGE	26-Jul-13
PCN13021	51710-026LF	DESIGN CHANGE	26-Jul-13
PCN13021	51710-027LF	DESIGN CHANGE	26-Jul-13

PCN13021	51710-028LF	DESIGN CHANGE	26-Jul-13
PCN13021	51710-031LF	DESIGN CHANGE	26-Jul-13
PCN13021	51710-033LF	DESIGN CHANGE	26-Jul-13
PCN13021	51710-034LF	DESIGN CHANGE	26-Jul-13
PCN13021	51710-036LF	DESIGN CHANGE	26-Jul-13
PCN13021	51710-037LF	DESIGN CHANGE	26-Jul-13
PCN13021	51710-039LF	DESIGN CHANGE	26-Jul-13
PCN13021	51710-040LF	DESIGN CHANGE	26-Jul-13
PCN13021	51710-042LF	DESIGN CHANGE	26-Jul-13
PCN13021	51710-043LF	DESIGN CHANGE	26-Jul-13
PCN13021	51710-046LF	DESIGN CHANGE	26-Jul-13
PCN13021	51710-048LF	DESIGN CHANGE	26-Jul-13
PCN13021	51710-049LF	DESIGN CHANGE	26-Jul-13
PCN13021	51710-050LF	DESIGN CHANGE	26-Jul-13
PCN13021	51710-051LF	DESIGN CHANGE	26-Jul-13
PCN13021	51710-052LF	DESIGN CHANGE	26-Jul-13
PCN13021	51710-053LF	DESIGN CHANGE	26-Jul-13
PCN13021	51710-054LF	DESIGN CHANGE	26-Jul-13
PCN13021	51710-056LF	DESIGN CHANGE	26-Jul-13
PCN13021	51711-001	DESIGN CHANGE	26-Jul-13
PCN13021	51711-001LF	DESIGN CHANGE	26-Jul-13
PCN13021	51711-004LF	DESIGN CHANGE	26-Jul-13
PCN13021	51711-005LF	DESIGN CHANGE	26-Jul-13
PCN13021	51711-007LF	DESIGN CHANGE	26-Jul-13
PCN13021	51711-009LF	DESIGN CHANGE	26-Jul-13
PCN13021	51711-010LF	DESIGN CHANGE	26-Jul-13
PCN13021	51712-002	DESIGN CHANGE	26-Jul-13
PCN13021	51712-002LF	DESIGN CHANGE	26-Jul-13
PCN13021	51712-003	DESIGN CHANGE	26-Jul-13
PCN13021	51712-003LF	DESIGN CHANGE	26-Jul-13
PCN13021	51712-004	DESIGN CHANGE	26-Jul-13
PCN13021	51712-004LF	DESIGN CHANGE	26-Jul-13
PCN13021	51712-005	DESIGN CHANGE	26-Jul-13
PCN13021	51712-006	DESIGN CHANGE	26-Jul-13
PCN13021	51712-006LF	DESIGN CHANGE	26-Jul-13
PCN13021	51712-007LF	DESIGN CHANGE	26-Jul-13
PCN13021	51712-009	DESIGN CHANGE	26-Jul-13
PCN13021	51712-009LF	DESIGN CHANGE	26-Jul-13
PCN13021	51712-010LF	DESIGN CHANGE	26-Jul-13
PCN13021	51712-011LF	DESIGN CHANGE	26-Jul-13
PCN13021	51712-012	DESIGN CHANGE	26-Jul-13

PCN13021	51712-012GXTLF	DESIGN CHANGE	26-Jul-13
PCN13021	51712-012LF	DESIGN CHANGE	26-Jul-13
PCN13021	51712-013LF	DESIGN CHANGE	26-Jul-13
PCN13021	51712-015LF	DESIGN CHANGE	26-Jul-13
PCN13021	51712-019LF	DESIGN CHANGE	26-Jul-13
PCN13021	51716-001	DESIGN CHANGE	26-Jul-13
PCN13021	51716-001LF	DESIGN CHANGE	26-Jul-13
PCN13021	51716-002LF	DESIGN CHANGE	26-Jul-13
PCN13021	51720-10001204AALF	DESIGN CHANGE	26-Jul-13
PCN13021	51720-10001604AA	DESIGN CHANGE	26-Jul-13
PCN13021	51720-10002004AA	DESIGN CHANGE	26-Jul-13
PCN13021	51720-10002004AALF	DESIGN CHANGE	26-Jul-13
PCN13021	51720-10002403AALF	DESIGN CHANGE	26-Jul-13
PCN13021	51720-10002412AA	DESIGN CHANGE	26-Jul-13
PCN13021	51720-10002412AALF	DESIGN CHANGE	26-Jul-13
PCN13021	51720-10002806AA	DESIGN CHANGE	26-Jul-13
PCN13021	51720-10003200AA	DESIGN CHANGE	26-Jul-13
PCN13021	51720-10003606AA	DESIGN CHANGE	26-Jul-13
PCN13021	51720-10003606AALF	DESIGN CHANGE	26-Jul-13
PCN13021	51720-10004000AA	DESIGN CHANGE	26-Jul-13
PCN13021	51720-10004400AA	DESIGN CHANGE	26-Jul-13
PCN13021	51720-10007200AA	DESIGN CHANGE	26-Jul-13
PCN13021	51720-10014800AA	DESIGN CHANGE	26-Jul-13
PCN13021	51720-10014800AB	DESIGN CHANGE	26-Jul-13
PCN13021	51720-10100401AA	DESIGN CHANGE	26-Jul-13
PCN13021	51720-10100401AALF	DESIGN CHANGE	26-Jul-13
PCN13021	51720-10100801AALF	DESIGN CHANGE	26-Jul-13
PCN13021	51720-10101201AA	DESIGN CHANGE	26-Jul-13
PCN13021	51720-10101201AALF	DESIGN CHANGE	26-Jul-13
PCN13021	51720-10101201ABLF	DESIGN CHANGE	26-Jul-13
PCN13021	51720-10101601AA	DESIGN CHANGE	26-Jul-13
PCN13021	51720-10101601AALF	DESIGN CHANGE	26-Jul-13
PCN13021	51720-10101601AB	DESIGN CHANGE	26-Jul-13
PCN13021	51720-10101601ABLF	DESIGN CHANGE	26-Jul-13
PCN13021	51720-10102001AA	DESIGN CHANGE	26-Jul-13
PCN13021	51720-10102401AA	DESIGN CHANGE	26-Jul-13
PCN13021	51720-10102401AALF	DESIGN CHANGE	26-Jul-13
PCN13021	51720-10102401AB	DESIGN CHANGE	26-Jul-13
PCN13021	51720-10103201AA	DESIGN CHANGE	26-Jul-13
PCN13021	51720-10103201AALF	DESIGN CHANGE	26-Jul-13
PCN13021	51720-10103201AB	DESIGN CHANGE	26-Jul-13

PCN13021	51720-10103201ABLF	DESIGN CHANGE	26-Jul-13
PCN13021	51720-10103601AALF	DESIGN CHANGE	26-Jul-13
PCN13021	51720-10104001AALF	DESIGN CHANGE	26-Jul-13
PCN13021	51720-10104002AALF	DESIGN CHANGE	26-Jul-13
PCN13021	51720-10104401AALF	DESIGN CHANGE	26-Jul-13
PCN13021	51720-10104801AA	DESIGN CHANGE	26-Jul-13
PCN13021	51720-10104801AALF	DESIGN CHANGE	26-Jul-13
PCN13021	51720-10106001AA	DESIGN CHANGE	26-Jul-13
PCN13021	51720-10106001AALF	DESIGN CHANGE	26-Jul-13
PCN13021	51720-10106001AB	DESIGN CHANGE	26-Jul-13
PCN13021	51720-10106001ABLF	DESIGN CHANGE	26-Jul-13
PCN13021	51720-10106402AALF	DESIGN CHANGE	26-Jul-13
PCN13021	51720-10107201AALF	DESIGN CHANGE	26-Jul-13
PCN13021	51720-10107201ABLF	DESIGN CHANGE	26-Jul-13
PCN13021	51720-10108001AALF	DESIGN CHANGE	26-Jul-13
PCN13021	51720-10108001ABLF	DESIGN CHANGE	26-Jul-13
PCN13021	51720-10114801AA	DESIGN CHANGE	26-Jul-13
PCN13021	51720-10200402AALF	DESIGN CHANGE	26-Jul-13
PCN13021	51720-10200402AB	DESIGN CHANGE	26-Jul-13
PCN13021	51720-10200402ABLF	DESIGN CHANGE	26-Jul-13
PCN13021	51720-10200801AALF	DESIGN CHANGE	26-Jul-13
PCN13021	51720-10200802AALF	DESIGN CHANGE	26-Jul-13
PCN13021	51720-10200802AB	DESIGN CHANGE	26-Jul-13
PCN13021	51720-10200802ABLF	DESIGN CHANGE	26-Jul-13
PCN13021	51720-10201201AALF	DESIGN CHANGE	26-Jul-13
PCN13021	51720-10201202AA	DESIGN CHANGE	26-Jul-13
PCN13021	51720-10201202AALF	DESIGN CHANGE	26-Jul-13
PCN13021	51720-10201202AB	DESIGN CHANGE	26-Jul-13
PCN13021	51720-10201202ABLF	DESIGN CHANGE	26-Jul-13
PCN13021	51720-10201204AA	DESIGN CHANGE	26-Jul-13
PCN13021	51720-10201602AA	DESIGN CHANGE	26-Jul-13
PCN13021	51720-10201602AALF	DESIGN CHANGE	26-Jul-13
PCN13021	51720-10201602AB	DESIGN CHANGE	26-Jul-13
PCN13021	51720-10201602ABLF	DESIGN CHANGE	26-Jul-13
PCN13021	51720-10201604AALF	DESIGN CHANGE	26-Jul-13
PCN13021	51720-10201606AALF	DESIGN CHANGE	26-Jul-13
PCN13021	51720-10202002AA	DESIGN CHANGE	26-Jul-13
PCN13021	51720-10202002AALF	DESIGN CHANGE	26-Jul-13
PCN13021	51720-10202402AA	DESIGN CHANGE	26-Jul-13
PCN13021	51720-10202402AALF	DESIGN CHANGE	26-Jul-13
PCN13021	51720-10202402AB	DESIGN CHANGE	26-Jul-13

PCN13021	51720-10202402ABLF	DESIGN CHANGE	26-Jul-13
PCN13021	51720-10202403AA	DESIGN CHANGE	26-Jul-13
PCN13021	51720-10202403AALF	DESIGN CHANGE	26-Jul-13
PCN13021	51720-10202404AA	DESIGN CHANGE	26-Jul-13
PCN13021	51720-10202404AALF	DESIGN CHANGE	26-Jul-13
PCN13021	51720-10202404AB	DESIGN CHANGE	26-Jul-13
PCN13021	51720-10202404ABLF	DESIGN CHANGE	26-Jul-13
PCN13021	51720-10202406AA	DESIGN CHANGE	26-Jul-13
PCN13021	51720-10202408AA	DESIGN CHANGE	26-Jul-13
PCN13021	51720-10202408AALF	DESIGN CHANGE	26-Jul-13
PCN13021	51720-10202408AB	DESIGN CHANGE	26-Jul-13
PCN13021	51720-10202408ABLF	DESIGN CHANGE	26-Jul-13
PCN13021	51720-10202814ABLF	DESIGN CHANGE	26-Jul-13
PCN13021	51720-10203202AA	DESIGN CHANGE	26-Jul-13
PCN13021	51720-10203206AA	DESIGN CHANGE	26-Jul-13
PCN13021	51720-10203206AALF	DESIGN CHANGE	26-Jul-13
PCN13021	51720-10203603AA	DESIGN CHANGE	26-Jul-13
PCN13021	51720-10203604AA	DESIGN CHANGE	26-Jul-13
PCN13021	51720-10203606AA	DESIGN CHANGE	26-Jul-13
PCN13021	51720-10204002AALF	DESIGN CHANGE	26-Jul-13
PCN13021	51720-10204800AALF	DESIGN CHANGE	26-Jul-13
PCN13021	51720-10204802AA	DESIGN CHANGE	26-Jul-13
PCN13021	51720-10204802AALF	DESIGN CHANGE	26-Jul-13
PCN13021	51720-10206002AA	DESIGN CHANGE	26-Jul-13
PCN13021	51720-10206002AALF	DESIGN CHANGE	26-Jul-13
PCN13021	51720-10206802AALF	DESIGN CHANGE	26-Jul-13
PCN13021	51720-10207202AALF	DESIGN CHANGE	26-Jul-13
PCN13021	51720-10208002AA	DESIGN CHANGE	26-Jul-13
PCN13021	51720-10208002AALF	DESIGN CHANGE	26-Jul-13
PCN13021	51720-10209602AALF	DESIGN CHANGE	26-Jul-13
PCN13021	51720-10210001AB	DESIGN CHANGE	26-Jul-13
PCN13021	51720-10210002AA	DESIGN CHANGE	26-Jul-13
PCN13021	51720-10212402AA	DESIGN CHANGE	26-Jul-13
PCN13021	51720-10300403AB	DESIGN CHANGE	26-Jul-13
PCN13021	51720-10300403ABLF	DESIGN CHANGE	26-Jul-13
PCN13021	51720-10300801AALF	DESIGN CHANGE	26-Jul-13
PCN13021	51720-10300802AB	DESIGN CHANGE	26-Jul-13
PCN13021	51720-10300803AA	DESIGN CHANGE	26-Jul-13
PCN13021	51720-10300803AALF	DESIGN CHANGE	26-Jul-13
PCN13021	51720-10300803AB	DESIGN CHANGE	26-Jul-13
PCN13021	51720-10301203AA	DESIGN CHANGE	26-Jul-13



PCN13021	51720-10301203AALF	DESIGN CHANGE	26-Jul-13
PCN13021	51720-10301602AA	DESIGN CHANGE	26-Jul-13
PCN13021	51720-10301602AALF	DESIGN CHANGE	26-Jul-13
PCN13021	51720-10301603AALF	DESIGN CHANGE	26-Jul-13
PCN13021	51720-10301603AB	DESIGN CHANGE	26-Jul-13
PCN13021	51720-10301603ABLF	DESIGN CHANGE	26-Jul-13
PCN13021	51720-10301604AALF	DESIGN CHANGE	26-Jul-13
PCN13021	51720-10301608AA	DESIGN CHANGE	26-Jul-13
PCN13021	51720-10301611AA	DESIGN CHANGE	26-Jul-13
PCN13021	51720-10302003AA	DESIGN CHANGE	26-Jul-13
PCN13021	51720-10302003AALF	DESIGN CHANGE	26-Jul-13
PCN13021	51720-10302003AB	DESIGN CHANGE	26-Jul-13
PCN13021	51720-10302004AA	DESIGN CHANGE	26-Jul-13
PCN13021	51720-10302005AA	DESIGN CHANGE	26-Jul-13
PCN13021	51720-10302005AALF	DESIGN CHANGE	26-Jul-13
PCN13021	51720-10302008AA	DESIGN CHANGE	26-Jul-13
PCN13021	51720-10302008AB	DESIGN CHANGE	26-Jul-13
PCN13021	51720-10302402AALF	DESIGN CHANGE	26-Jul-13
PCN13021	51720-10302403AA	DESIGN CHANGE	26-Jul-13
PCN13021	51720-10302403AALF	DESIGN CHANGE	26-Jul-13
PCN13021	51720-10302403AB	DESIGN CHANGE	26-Jul-13
PCN13021	51720-10302403ABLF	DESIGN CHANGE	26-Jul-13
PCN13021	51720-10302405AA	DESIGN CHANGE	26-Jul-13
PCN13021	51720-10302406AA	DESIGN CHANGE	26-Jul-13
PCN13021	51720-10302406AALF	DESIGN CHANGE	26-Jul-13
PCN13021	51720-10302408AALF	DESIGN CHANGE	26-Jul-13
PCN13021	51720-10302803AALF	DESIGN CHANGE	26-Jul-13
PCN13021	51720-10302808AA	DESIGN CHANGE	26-Jul-13
PCN13021	51720-10303203AALF	DESIGN CHANGE	26-Jul-13
PCN13021	51720-10303203ABLF	DESIGN CHANGE	26-Jul-13
PCN13021	51720-10303603AA	DESIGN CHANGE	26-Jul-13
PCN13021	51720-10303603AALF	DESIGN CHANGE	26-Jul-13
PCN13021	51720-10306402AALF	DESIGN CHANGE	26-Jul-13
PCN13021	51720-10306802AALF	DESIGN CHANGE	26-Jul-13
PCN13021	51720-10312003AB	DESIGN CHANGE	26-Jul-13
PCN13021	51720-10312003ABLF	DESIGN CHANGE	26-Jul-13
PCN13021	51720-10312803AB	DESIGN CHANGE	26-Jul-13
PCN13021	51720-10312803ABLF	DESIGN CHANGE	26-Jul-13
PCN13021	51720-10400804AA	DESIGN CHANGE	26-Jul-13
PCN13021	51720-10400804AALF	DESIGN CHANGE	26-Jul-13
PCN13021	51720-10400804AB	DESIGN CHANGE	26-Jul-13

PCN13021	51720-10401202AALF	DESIGN CHANGE	26-Jul-13
PCN13021	51720-10401204AA	DESIGN CHANGE	26-Jul-13
PCN13021	51720-10401204AALF	DESIGN CHANGE	26-Jul-13
PCN13021	51720-10401204AB	DESIGN CHANGE	26-Jul-13
PCN13021	51720-10401204ABLF	DESIGN CHANGE	26-Jul-13
PCN13021	51720-10401602AA	DESIGN CHANGE	26-Jul-13
PCN13021	51720-10401602AALF	DESIGN CHANGE	26-Jul-13
PCN13021	51720-10401602AB	DESIGN CHANGE	26-Jul-13
PCN13021	51720-10401602ABLF	DESIGN CHANGE	26-Jul-13
PCN13021	51720-10401603AA	DESIGN CHANGE	26-Jul-13
PCN13021	51720-10401603AALF	DESIGN CHANGE	26-Jul-13
PCN13021	51720-10401604AALF	DESIGN CHANGE	26-Jul-13
PCN13021	51720-10401604ABLF	DESIGN CHANGE	26-Jul-13
PCN13021	51720-10402002AA	DESIGN CHANGE	26-Jul-13
PCN13021	51720-10402002AALF	DESIGN CHANGE	26-Jul-13
PCN13021	51720-10402003AALF	DESIGN CHANGE	26-Jul-13
PCN13021	51720-10402004AALF	DESIGN CHANGE	26-Jul-13
PCN13021	51720-10402004AB	DESIGN CHANGE	26-Jul-13
PCN13021	51720-10402004ABLF	DESIGN CHANGE	26-Jul-13
PCN13021	51720-10402006AB	DESIGN CHANGE	26-Jul-13
PCN13021	51720-10402402AA	DESIGN CHANGE	26-Jul-13
PCN13021	51720-10402402AALF	DESIGN CHANGE	26-Jul-13
PCN13021	51720-10402402ABLF	DESIGN CHANGE	26-Jul-13
PCN13021	51720-10402403AA	DESIGN CHANGE	26-Jul-13
PCN13021	51720-10402403AALF	DESIGN CHANGE	26-Jul-13
PCN13021	51720-10402404AA	DESIGN CHANGE	26-Jul-13
PCN13021	51720-10402404AALF	DESIGN CHANGE	26-Jul-13
PCN13021	51720-10402404AB	DESIGN CHANGE	26-Jul-13
PCN13021	51720-10402404ABLF	DESIGN CHANGE	26-Jul-13
PCN13021	51720-10402405AALF	DESIGN CHANGE	26-Jul-13
PCN13021	51720-10402405AB	DESIGN CHANGE	26-Jul-13
PCN13021	51720-10402405ABLF	DESIGN CHANGE	26-Jul-13
PCN13021	51720-10402406AA	DESIGN CHANGE	26-Jul-13
PCN13021	51720-10402406AALF	DESIGN CHANGE	26-Jul-13
PCN13021	51720-10402406AB	DESIGN CHANGE	26-Jul-13
PCN13021	51720-10402406ABLF	DESIGN CHANGE	26-Jul-13
PCN13021	51720-10402408AA	DESIGN CHANGE	26-Jul-13
PCN13021	51720-10402408AB	DESIGN CHANGE	26-Jul-13
PCN13021	51720-10402804AA	DESIGN CHANGE	26-Jul-13
PCN13021	51720-10402804AALF	DESIGN CHANGE	26-Jul-13
PCN13021	51720-10403204AALF	DESIGN CHANGE	26-Jul-13

PCN13021	51720-10403602AA	DESIGN CHANGE	26-Jul-13
PCN13021	51720-10404004AA	DESIGN CHANGE	26-Jul-13
PCN13021	51720-10404004AALF	DESIGN CHANGE	26-Jul-13
PCN13021	51720-10404804AA	DESIGN CHANGE	26-Jul-13
PCN13021	51720-10404804AALF	DESIGN CHANGE	26-Jul-13
PCN13021	51720-10404804AB	DESIGN CHANGE	26-Jul-13
PCN13021	51720-10404804ABLF	DESIGN CHANGE	26-Jul-13
PCN13021	51720-10405604ABLF	DESIGN CHANGE	26-Jul-13
PCN13021	51720-10408004AALF	DESIGN CHANGE	26-Jul-13
PCN13021	51720-10410004AA	DESIGN CHANGE	26-Jul-13
PCN13021	51720-10410004AALF	DESIGN CHANGE	26-Jul-13
PCN13021	51720-10500805AA	DESIGN CHANGE	26-Jul-13
PCN13021	51720-10500805AALF	DESIGN CHANGE	26-Jul-13
PCN13021	51720-10500806AA	DESIGN CHANGE	26-Jul-13
PCN13021	51720-10501205AA	DESIGN CHANGE	26-Jul-13
PCN13021	51720-10501605ABLF	DESIGN CHANGE	26-Jul-13
PCN13021	51720-10502002AALF	DESIGN CHANGE	26-Jul-13
PCN13021	51720-10502005AA	DESIGN CHANGE	26-Jul-13
PCN13021	51720-10502400AALF	DESIGN CHANGE	26-Jul-13
PCN13021	51720-10502402AA	DESIGN CHANGE	26-Jul-13
PCN13021	51720-10502402ABLF	DESIGN CHANGE	26-Jul-13
PCN13021	51720-10502403AB	DESIGN CHANGE	26-Jul-13
PCN13021	51720-10502403ABLF	DESIGN CHANGE	26-Jul-13
PCN13021	51720-10502404AALF	DESIGN CHANGE	26-Jul-13
PCN13021	51720-10502405AA	DESIGN CHANGE	26-Jul-13
PCN13021	51720-10502405AALF	DESIGN CHANGE	26-Jul-13
PCN13021	51720-10502406AA	DESIGN CHANGE	26-Jul-13
PCN13021	51720-10502410AALF	DESIGN CHANGE	26-Jul-13
PCN13021	51720-10503205AA	DESIGN CHANGE	26-Jul-13
PCN13021	51720-10503205AALF	DESIGN CHANGE	26-Jul-13
PCN13021	51720-10503606AA	DESIGN CHANGE	26-Jul-13
PCN13021	51720-10504004AA	DESIGN CHANGE	26-Jul-13
PCN13021	51720-10600802AA	DESIGN CHANGE	26-Jul-13
PCN13021	51720-10601602AALF	DESIGN CHANGE	26-Jul-13
PCN13021	51720-10601603AB	DESIGN CHANGE	26-Jul-13
PCN13021	51720-10601603ABLF	DESIGN CHANGE	26-Jul-13
PCN13021	51720-10601604ABLF	DESIGN CHANGE	26-Jul-13
PCN13021	51720-10602005AB	DESIGN CHANGE	26-Jul-13
PCN13021	51720-10602005ABLF	DESIGN CHANGE	26-Jul-13
PCN13021	51720-10602006AA	DESIGN CHANGE	26-Jul-13
PCN13021	51720-10602402AA	DESIGN CHANGE	26-Jul-13

PCN13021	51720-10602402AALF	DESIGN CHANGE	26-Jul-13
PCN13021	51720-10602404ABLF	DESIGN CHANGE	26-Jul-13
PCN13021	51720-10602405AA	DESIGN CHANGE	26-Jul-13
PCN13021	51720-10602405AALF	DESIGN CHANGE	26-Jul-13
PCN13021	51720-10602405ABLF	DESIGN CHANGE	26-Jul-13
PCN13021	51720-10602406AA	DESIGN CHANGE	26-Jul-13
PCN13021	51720-10602406AALF	DESIGN CHANGE	26-Jul-13
PCN13021	51720-10602408AA	DESIGN CHANGE	26-Jul-13
PCN13021	51720-10602804AA	DESIGN CHANGE	26-Jul-13
PCN13021	51720-10602804AB	DESIGN CHANGE	26-Jul-13
PCN13021	51720-10602804ABLF	DESIGN CHANGE	26-Jul-13
PCN13021	51720-10602805AA	DESIGN CHANGE	26-Jul-13
PCN13021	51720-10602806AA	DESIGN CHANGE	26-Jul-13
PCN13021	51720-10602806AALF	DESIGN CHANGE	26-Jul-13
PCN13021	51720-10602807AB	DESIGN CHANGE	26-Jul-13
PCN13021	51720-10602807ABLF	DESIGN CHANGE	26-Jul-13
PCN13021	51720-10602808AA	DESIGN CHANGE	26-Jul-13
PCN13021	51720-10602808AB	DESIGN CHANGE	26-Jul-13
PCN13021	51720-10602808ABLF	DESIGN CHANGE	26-Jul-13
PCN13021	51720-10603204AALF	DESIGN CHANGE	26-Jul-13
PCN13021	51720-10603206AB	DESIGN CHANGE	26-Jul-13
PCN13021	51720-10603207AB	DESIGN CHANGE	26-Jul-13
PCN13021	51720-10605206AA	DESIGN CHANGE	26-Jul-13
PCN13021	51720-10606006AA	DESIGN CHANGE	26-Jul-13
PCN13021	51720-10606006AALF	DESIGN CHANGE	26-Jul-13
PCN13021	51720-10700807AA	DESIGN CHANGE	26-Jul-13
PCN13021	51720-10700807AB	DESIGN CHANGE	26-Jul-13
PCN13021	51720-10701607AB	DESIGN CHANGE	26-Jul-13
PCN13021	51720-10701607ABLF	DESIGN CHANGE	26-Jul-13
PCN13021	51720-10702406AA	DESIGN CHANGE	26-Jul-13
PCN13021	51720-10702407AA	DESIGN CHANGE	26-Jul-13
PCN13021	51720-10702407AALF	DESIGN CHANGE	26-Jul-13
PCN13021	51720-10702807AB	DESIGN CHANGE	26-Jul-13
PCN13021	51720-10702807ABLF	DESIGN CHANGE	26-Jul-13
PCN13021	51720-10702809AA	DESIGN CHANGE	26-Jul-13
PCN13021	51720-10703206AA	DESIGN CHANGE	26-Jul-13
PCN13021	51720-10703206AALF	DESIGN CHANGE	26-Jul-13
PCN13021	51720-10704000AA	DESIGN CHANGE	26-Jul-13
PCN13021	51720-10802407AB	DESIGN CHANGE	26-Jul-13
PCN13021	51720-10802408AA	DESIGN CHANGE	26-Jul-13
PCN13021	51720-10802408AALF	DESIGN CHANGE	26-Jul-13

PCN13021	51720-10802808AA	DESIGN CHANGE	26-Jul-13
PCN13021	51720-10803208AA	DESIGN CHANGE	26-Jul-13
PCN13021	51720-10803208AALF	DESIGN CHANGE	26-Jul-13
PCN13021	51720-10803208ABLF	DESIGN CHANGE	26-Jul-13
PCN13021	51720-10808408AB	DESIGN CHANGE	26-Jul-13
PCN13021	51720-10901609AA	DESIGN CHANGE	26-Jul-13
PCN13021	51720-10902409AALF	DESIGN CHANGE	26-Jul-13
PCN13021	51720-10903204AALF	DESIGN CHANGE	26-Jul-13
PCN13021	51720-10909209AB	DESIGN CHANGE	26-Jul-13
PCN13021	51720-11002006AALF	DESIGN CHANGE	26-Jul-13
PCN13021	51720-11002410AA	DESIGN CHANGE	26-Jul-13
PCN13021	51720-11003210AALF	DESIGN CHANGE	26-Jul-13
PCN13021	51720-11004810AA	DESIGN CHANGE	26-Jul-13
PCN13021	51720-11008410AA	DESIGN CHANGE	26-Jul-13
PCN13021	51720-11008410AALF	DESIGN CHANGE	26-Jul-13
PCN13021	51720-11102003AA	DESIGN CHANGE	26-Jul-13
PCN13021	51720-11102003AALF	DESIGN CHANGE	26-Jul-13
PCN13021	51720-11202002AA	DESIGN CHANGE	26-Jul-13
PCN13021	51721-10000404AA	DESIGN CHANGE	26-Jul-13
PCN13021	51721-10000404AALF	DESIGN CHANGE	26-Jul-13
PCN13021	51721-10000404ABLF	DESIGN CHANGE	26-Jul-13
PCN13021	51721-10000405AALF	DESIGN CHANGE	26-Jul-13
PCN13021	51721-10000406AA	DESIGN CHANGE	26-Jul-13
PCN13021	51721-10000406AALF	DESIGN CHANGE	26-Jul-13
PCN13021	51721-10000802AALF	DESIGN CHANGE	26-Jul-13
PCN13021	51721-10000804AA	DESIGN CHANGE	26-Jul-13
PCN13021	51721-10000804AALF	DESIGN CHANGE	26-Jul-13
PCN13021	51721-10000805AALF	DESIGN CHANGE	26-Jul-13
PCN13021	51721-10000806AA	DESIGN CHANGE	26-Jul-13
PCN13021	51721-10000806ABLF	DESIGN CHANGE	26-Jul-13
PCN13021	51721-10000807AA	DESIGN CHANGE	26-Jul-13
PCN13021	51721-10000807AALF	DESIGN CHANGE	26-Jul-13
PCN13021	51721-10000808AA	DESIGN CHANGE	26-Jul-13
PCN13021	51721-10000810AA	DESIGN CHANGE	26-Jul-13
PCN13021	51721-10000810AALF	DESIGN CHANGE	26-Jul-13
PCN13021	51721-10000812AALF	DESIGN CHANGE	26-Jul-13
PCN13021	51721-10001204AA	DESIGN CHANGE	26-Jul-13
PCN13021	51721-10001204AALF	DESIGN CHANGE	26-Jul-13
PCN13021	51721-10001204ABLF	DESIGN CHANGE	26-Jul-13
PCN13021	51721-10001206AA	DESIGN CHANGE	26-Jul-13
PCN13021	51721-10001206AALF	DESIGN CHANGE	26-Jul-13

PCN13021	51721-10001206ABLF	DESIGN CHANGE	26-Jul-13
PCN13021	51721-10001208AALF	DESIGN CHANGE	26-Jul-13
PCN13021	51721-10001218AALF	DESIGN CHANGE	26-Jul-13
PCN13021	51721-10001218ABLF	DESIGN CHANGE	26-Jul-13
PCN13021	51721-10001602AALF	DESIGN CHANGE	26-Jul-13
PCN13021	51721-10001604AA	DESIGN CHANGE	26-Jul-13
PCN13021	51721-10001604AALF	DESIGN CHANGE	26-Jul-13
PCN13021	51721-10001605ABLF	DESIGN CHANGE	26-Jul-13
PCN13021	51721-10001606AA	DESIGN CHANGE	26-Jul-13
PCN13021	51721-10001606AALF	DESIGN CHANGE	26-Jul-13
PCN13021	51721-10001608AA	DESIGN CHANGE	26-Jul-13
PCN13021	51721-10001608AALF	DESIGN CHANGE	26-Jul-13
PCN13021	51721-10001608ABLF	DESIGN CHANGE	26-Jul-13
PCN13021	51721-10001609AA	DESIGN CHANGE	26-Jul-13
PCN13021	51721-10001614AB	DESIGN CHANGE	26-Jul-13
PCN13021	51721-10002004AA	DESIGN CHANGE	26-Jul-13
PCN13021	51721-10002004AALF	DESIGN CHANGE	26-Jul-13
PCN13021	51721-10002006AALF	DESIGN CHANGE	26-Jul-13
PCN13021	51721-10002006AB	DESIGN CHANGE	26-Jul-13
PCN13021	51721-10002006ABLF	DESIGN CHANGE	26-Jul-13
PCN13021	51721-10002007AA	DESIGN CHANGE	26-Jul-13
PCN13021	51721-10002402AA	DESIGN CHANGE	26-Jul-13
PCN13021	51721-10002403AB	DESIGN CHANGE	26-Jul-13
PCN13021	51721-10002403ABLF	DESIGN CHANGE	26-Jul-13
PCN13021	51721-10002404AA	DESIGN CHANGE	26-Jul-13
PCN13021	51721-10002404AALF	DESIGN CHANGE	26-Jul-13
PCN13021	51721-10002404ABLF	DESIGN CHANGE	26-Jul-13
PCN13021	51721-10002405AA	DESIGN CHANGE	26-Jul-13
PCN13021	51721-10002406AA	DESIGN CHANGE	26-Jul-13
PCN13021	51721-10002406AALF	DESIGN CHANGE	26-Jul-13
PCN13021	51721-10002406AB	DESIGN CHANGE	26-Jul-13
PCN13021	51721-10002406ABLF	DESIGN CHANGE	26-Jul-13
PCN13021	51721-10002407AB	DESIGN CHANGE	26-Jul-13
PCN13021	51721-10002407ABLF	DESIGN CHANGE	26-Jul-13
PCN13021	51721-10002408AALF	DESIGN CHANGE	26-Jul-13
PCN13021	51721-10002408AB	DESIGN CHANGE	26-Jul-13
PCN13021	51721-10002408ABLF	DESIGN CHANGE	26-Jul-13
PCN13021	51721-10002409AALF	DESIGN CHANGE	26-Jul-13
PCN13021	51721-10002409ABLF	DESIGN CHANGE	26-Jul-13
PCN13021	51721-10002410AA	DESIGN CHANGE	26-Jul-13
PCN13021	51721-10002410AALF	DESIGN CHANGE	26-Jul-13

PCN13021	51721-10002410AB	DESIGN CHANGE	26-Jul-13
PCN13021	51721-10002410ABLF	DESIGN CHANGE	26-Jul-13
PCN13021	51721-10002412AALF	DESIGN CHANGE	26-Jul-13
PCN13021	51721-10002412AB	DESIGN CHANGE	26-Jul-13
PCN13021	51721-10002412ABLF	DESIGN CHANGE	26-Jul-13
PCN13021	51721-10002414AA	DESIGN CHANGE	26-Jul-13
PCN13021	51721-10002414AALF	DESIGN CHANGE	26-Jul-13
PCN13021	51721-10002414AB	DESIGN CHANGE	26-Jul-13
PCN13021	51721-10002415AA	DESIGN CHANGE	26-Jul-13
PCN13021	51721-10002416AALF	DESIGN CHANGE	26-Jul-13
PCN13021	51721-10002420ABLF	DESIGN CHANGE	26-Jul-13
PCN13021	51721-10002806AALF	DESIGN CHANGE	26-Jul-13
PCN13021	51721-10002806ABLF	DESIGN CHANGE	26-Jul-13
PCN13021	51721-10002808AALF	DESIGN CHANGE	26-Jul-13
PCN13021	51721-10003202AALF	DESIGN CHANGE	26-Jul-13
PCN13021	51721-10003204AALF	DESIGN CHANGE	26-Jul-13
PCN13021	51721-10003206ABLF	DESIGN CHANGE	26-Jul-13
PCN13021	51721-10003208AALF	DESIGN CHANGE	26-Jul-13
PCN13021	51721-10003603AA	DESIGN CHANGE	26-Jul-13
PCN13021	51721-10003605AALF	DESIGN CHANGE	26-Jul-13
PCN13021	51721-10003615AA	DESIGN CHANGE	26-Jul-13
PCN13021	51721-10004006AALF	DESIGN CHANGE	26-Jul-13
PCN13021	51721-10004007ABLF	DESIGN CHANGE	26-Jul-13
PCN13021	51721-10004802AALF	DESIGN CHANGE	26-Jul-13
PCN13021	51721-10004803AALF	DESIGN CHANGE	26-Jul-13
PCN13021	51721-10004808AB	DESIGN CHANGE	26-Jul-13
PCN13021	51721-10004808ABLF	DESIGN CHANGE	26-Jul-13
PCN13021	51721-10005611ABLF	DESIGN CHANGE	26-Jul-13
PCN13021	51721-10006017AA	DESIGN CHANGE	26-Jul-13
PCN13021	51721-10006017AB	DESIGN CHANGE	26-Jul-13
PCN13021	51721-10006020AB	DESIGN CHANGE	26-Jul-13
PCN13021	51721-10006402ABLF	DESIGN CHANGE	26-Jul-13
PCN13021	51721-10006403AALF	DESIGN CHANGE	26-Jul-13
PCN13021	51721-10007205ABLF	DESIGN CHANGE	26-Jul-13
PCN13021	51721-10009220AA	DESIGN CHANGE	26-Jul-13
PCN13021	51722-10102400AA	DESIGN CHANGE	26-Jul-13
PCN13021	51722-10103600AA	DESIGN CHANGE	26-Jul-13
PCN13021	51722-10103600AALF	DESIGN CHANGE	26-Jul-13
PCN13021	51722-10200400AA	DESIGN CHANGE	26-Jul-13
PCN13021	51722-10200400AALF	DESIGN CHANGE	26-Jul-13
PCN13021	51722-10200800AALF	DESIGN CHANGE	26-Jul-13

PCN13021	51722-10201200AA	DESIGN CHANGE	26-Jul-13
PCN13021	51722-10201200AB	DESIGN CHANGE	26-Jul-13
PCN13021	51722-10201200ABLF	DESIGN CHANGE	26-Jul-13
PCN13021	51722-10201600AA	DESIGN CHANGE	26-Jul-13
PCN13021	51722-10201600AALF	DESIGN CHANGE	26-Jul-13
PCN13021	51722-10202000AALF	DESIGN CHANGE	26-Jul-13
PCN13021	51722-10202000ABLF	DESIGN CHANGE	26-Jul-13
PCN13021	51722-10202400AA	DESIGN CHANGE	26-Jul-13
PCN13021	51722-10202400AALF	DESIGN CHANGE	26-Jul-13
PCN13021	51722-10203200AALF	DESIGN CHANGE	26-Jul-13
PCN13021	51722-10203600AALF	DESIGN CHANGE	26-Jul-13
PCN13021	51722-10203600AB	DESIGN CHANGE	26-Jul-13
PCN13021	51722-10204000AALF	DESIGN CHANGE	26-Jul-13
PCN13021	51722-10204800AALF	DESIGN CHANGE	26-Jul-13
PCN13021	51722-10207600AALF	DESIGN CHANGE	26-Jul-13
PCN13021	51722-10214400ABLF	DESIGN CHANGE	26-Jul-13
PCN13021	51722-10301200AA	DESIGN CHANGE	26-Jul-13
PCN13021	51722-10301600AALF	DESIGN CHANGE	26-Jul-13
PCN13021	51722-10302400AA	DESIGN CHANGE	26-Jul-13
PCN13021	51722-10302400AALF	DESIGN CHANGE	26-Jul-13
PCN13021	51722-10302400AB	DESIGN CHANGE	26-Jul-13
PCN13021	51722-10303200AALF	DESIGN CHANGE	26-Jul-13
PCN13021	51722-10400800AA	DESIGN CHANGE	26-Jul-13
PCN13021	51722-10400800AALF	DESIGN CHANGE	26-Jul-13
PCN13021	51722-10400800ABLF	DESIGN CHANGE	26-Jul-13
PCN13021	51722-10401200AA	DESIGN CHANGE	26-Jul-13
PCN13021	51722-10401200AALF	DESIGN CHANGE	26-Jul-13
PCN13021	51722-10401200ABLF	DESIGN CHANGE	26-Jul-13
PCN13021	51722-10401600AA	DESIGN CHANGE	26-Jul-13
PCN13021	51722-10401600AALF	DESIGN CHANGE	26-Jul-13
PCN13021	51722-10401600AB	DESIGN CHANGE	26-Jul-13
PCN13021	51722-10401600ABLF	DESIGN CHANGE	26-Jul-13
PCN13021	51722-10402000AALF	DESIGN CHANGE	26-Jul-13
PCN13021	51722-10402400AA	DESIGN CHANGE	26-Jul-13
PCN13021	51722-10402400AALF	DESIGN CHANGE	26-Jul-13
PCN13021	51722-10402400ABLF	DESIGN CHANGE	26-Jul-13
PCN13021	51722-10403200AALF	DESIGN CHANGE	26-Jul-13
PCN13021	51722-10403600AA	DESIGN CHANGE	26-Jul-13
PCN13021	51722-10406000AA	DESIGN CHANGE	26-Jul-13
PCN13021	51722-10406000AALF	DESIGN CHANGE	26-Jul-13
PCN13021	51722-10407200AALF	DESIGN CHANGE	26-Jul-13



PCN13021	51722-10412000AALF	DESIGN CHANGE	26-Jul-13
PCN13021	51722-10412000AB	DESIGN CHANGE	26-Jul-13
PCN13021	51722-10501600AA	DESIGN CHANGE	26-Jul-13
PCN13021	51722-10502400AA	DESIGN CHANGE	26-Jul-13
PCN13021	51722-10502400AALF	DESIGN CHANGE	26-Jul-13
PCN13021	51722-10502400AB	DESIGN CHANGE	26-Jul-13
PCN13021	51722-10600400AA	DESIGN CHANGE	26-Jul-13
PCN13021	51722-10600400AB	DESIGN CHANGE	26-Jul-13
PCN13021	51722-10600800AA	DESIGN CHANGE	26-Jul-13
PCN13021	51722-10600800AALF	DESIGN CHANGE	26-Jul-13
PCN13021	51722-10601200AALF	DESIGN CHANGE	26-Jul-13
PCN13021	51722-10601600AA	DESIGN CHANGE	26-Jul-13
PCN13021	51722-10601600AALF	DESIGN CHANGE	26-Jul-13
PCN13021	51722-10601600ABLF	DESIGN CHANGE	26-Jul-13
PCN13021	51722-10602000AA	DESIGN CHANGE	26-Jul-13
PCN13021	51722-10602000AALF	DESIGN CHANGE	26-Jul-13
PCN13021	51722-10602000ABLF	DESIGN CHANGE	26-Jul-13
PCN13021	51722-10602400AA	DESIGN CHANGE	26-Jul-13
PCN13021	51722-10602400AALF	DESIGN CHANGE	26-Jul-13
PCN13021	51722-10602400ABLF	DESIGN CHANGE	26-Jul-13
PCN13021	51722-10603200AA	DESIGN CHANGE	26-Jul-13
PCN13021	51722-10603200AALF	DESIGN CHANGE	26-Jul-13
PCN13021	51722-10603600AA	DESIGN CHANGE	26-Jul-13
PCN13021	51722-10603600AALF	DESIGN CHANGE	26-Jul-13
PCN13021	51722-10604000AALF	DESIGN CHANGE	26-Jul-13
PCN13021	51722-10606000AALF	DESIGN CHANGE	26-Jul-13
PCN13021	51722-10610400AALF	DESIGN CHANGE	26-Jul-13
PCN13021	51722-10701600ABLF	DESIGN CHANGE	26-Jul-13
PCN13021	51722-10702400AA	DESIGN CHANGE	26-Jul-13
PCN13021	51722-10702400AALF	DESIGN CHANGE	26-Jul-13
PCN13021	51722-10704000AALF	DESIGN CHANGE	26-Jul-13
PCN13021	51722-10704000ABLF	DESIGN CHANGE	26-Jul-13
PCN13021	51722-10800800AALF	DESIGN CHANGE	26-Jul-13
PCN13021	51722-10801200AB	DESIGN CHANGE	26-Jul-13
PCN13021	51722-10801200ABLF	DESIGN CHANGE	26-Jul-13
PCN13021	51722-10801600AALF	DESIGN CHANGE	26-Jul-13
PCN13021	51722-10801600ABLF	DESIGN CHANGE	26-Jul-13
PCN13021	51722-10802400AA	DESIGN CHANGE	26-Jul-13
PCN13021	51722-10802400AALF	DESIGN CHANGE	26-Jul-13
PCN13021	51722-10802400AB	DESIGN CHANGE	26-Jul-13
PCN13021	51722-10802400ABLF	DESIGN CHANGE	26-Jul-13

PCN13021	51722-10802800ABLF	DESIGN CHANGE	26-Jul-13
PCN13021	51722-10900800AA	DESIGN CHANGE	26-Jul-13
PCN13021	51722-10901200ABLF	DESIGN CHANGE	26-Jul-13
PCN13021	51722-10901600AA	DESIGN CHANGE	26-Jul-13
PCN13021	51722-10901600AALF	DESIGN CHANGE	26-Jul-13
PCN13021	51722-10902000ABLF	DESIGN CHANGE	26-Jul-13
PCN13021	51722-10902400AALF	DESIGN CHANGE	26-Jul-13
PCN13021	51722-11000800AA	DESIGN CHANGE	26-Jul-13
PCN13021	51722-11000800ABLF	DESIGN CHANGE	26-Jul-13
PCN13021	51722-11001200AA	DESIGN CHANGE	26-Jul-13
PCN13021	51722-11001200AALF	DESIGN CHANGE	26-Jul-13
PCN13021	51722-11001600AALF	DESIGN CHANGE	26-Jul-13
PCN13021	51722-11001600ABLF	DESIGN CHANGE	26-Jul-13
PCN13021	51722-11002000ABLF	DESIGN CHANGE	26-Jul-13
PCN13021	51722-11002400AALF	DESIGN CHANGE	26-Jul-13
PCN13021	51722-11002400AB	DESIGN CHANGE	26-Jul-13
PCN13021	51722-11002400ABLF	DESIGN CHANGE	26-Jul-13
PCN13021	51722-11002800AALF	DESIGN CHANGE	26-Jul-13
PCN13021	51722-11002800ABLF	DESIGN CHANGE	26-Jul-13
PCN13021	51722-11102400AALF	DESIGN CHANGE	26-Jul-13
PCN13021	51722-11103200AA	DESIGN CHANGE	26-Jul-13
PCN13021	51722-11103200AALF	DESIGN CHANGE	26-Jul-13
PCN13021	51722-11201200AA	DESIGN CHANGE	26-Jul-13
PCN13021	51722-11201200AALF	DESIGN CHANGE	26-Jul-13
PCN13021	51722-11201600AA	DESIGN CHANGE	26-Jul-13
PCN13021	51722-11202000AA	DESIGN CHANGE	26-Jul-13
PCN13021	51722-11202000AALF	DESIGN CHANGE	26-Jul-13
PCN13021	51722-11202400ABLF	DESIGN CHANGE	26-Jul-13
PCN13021	51722-11402400AA	DESIGN CHANGE	26-Jul-13
PCN13021	51722-11402400AALF	DESIGN CHANGE	26-Jul-13
PCN13021	51722-11702800AA	DESIGN CHANGE	26-Jul-13
PCN13021	51722-12001200AALF	DESIGN CHANGE	26-Jul-13
PCN13021	51722-12002000AB	DESIGN CHANGE	26-Jul-13
PCN13021	51722-12002000ABLF	DESIGN CHANGE	26-Jul-13
PCN13021	51722-12002400AA	DESIGN CHANGE	26-Jul-13
PCN13021	51722-12002400AB	DESIGN CHANGE	26-Jul-13
PCN13021	51724-10014800A0	DESIGN CHANGE	26-Jul-13
PCN13021	51724-10100801AOLF	DESIGN CHANGE	26-Jul-13
PCN13021	51724-10101201AOLF	DESIGN CHANGE	26-Jul-13
PCN13021	51724-10102401A0	DESIGN CHANGE	26-Jul-13
PCN13021	51724-10102401AOLF	DESIGN CHANGE	26-Jul-13

PCN13021	51724-10114801A0	DESIGN CHANGE	26-Jul-13
PCN13021	51724-10200403A0	DESIGN CHANGE	26-Jul-13
PCN13021	51724-10202003A0	DESIGN CHANGE	26-Jul-13
PCN13021	51724-10202400A0	DESIGN CHANGE	26-Jul-13
PCN13021	51724-10202402A0	DESIGN CHANGE	26-Jul-13
PCN13021	51724-10203202A0	DESIGN CHANGE	26-Jul-13
PCN13021	51724-10301203A0	DESIGN CHANGE	26-Jul-13
PCN13021	51724-10301203A0LF	DESIGN CHANGE	26-Jul-13
PCN13021	51724-10301608A0LF	DESIGN CHANGE	26-Jul-13
PCN13021	51724-10301611A0LF	DESIGN CHANGE	26-Jul-13
PCN13021	51724-10302004A0	DESIGN CHANGE	26-Jul-13
PCN13021	51724-10501204A0LF	DESIGN CHANGE	26-Jul-13
PCN13021	51724-10601204A0	DESIGN CHANGE	26-Jul-13
PCN13021	51724-10601204A0LF	DESIGN CHANGE	26-Jul-13
PCN13021	51724-10601603A0LF	DESIGN CHANGE	26-Jul-13
PCN13021	51724-10700807A0	DESIGN CHANGE	26-Jul-13
PCN13021	51725-10000808A0LF	DESIGN CHANGE	26-Jul-13
PCN13021	51725-10001604A0	DESIGN CHANGE	26-Jul-13
PCN13021	51725-10002005A0	DESIGN CHANGE	26-Jul-13
PCN13021	51726-10102000A0	DESIGN CHANGE	26-Jul-13
PCN13021	51726-10200800A0	DESIGN CHANGE	26-Jul-13
PCN13021	51726-10200800A0LF	DESIGN CHANGE	26-Jul-13
PCN13021	51726-10201600A0	DESIGN CHANGE	26-Jul-13
PCN13021	51726-10201600A0LF	DESIGN CHANGE	26-Jul-13
PCN13021	51726-10300800A0LF	DESIGN CHANGE	26-Jul-13
PCN13021	51726-10402400A0	DESIGN CHANGE	26-Jul-13
PCN13021	51726-10402400A0LF	DESIGN CHANGE	26-Jul-13
PCN13021	51726-10502400A0	DESIGN CHANGE	26-Jul-13
PCN13021	51726-10505200A0LF	DESIGN CHANGE	26-Jul-13
PCN13021	51726-10802400A0	DESIGN CHANGE	26-Jul-13
PCN13021	51726-11001200A0	DESIGN CHANGE	26-Jul-13
PCN13021	51726-11001200A0LF	DESIGN CHANGE	26-Jul-13
PCN13021	51726-11301200A0	DESIGN CHANGE	26-Jul-13
PCN13021	51730-001	DESIGN CHANGE	26-Jul-13
PCN13021	51730-001LF	DESIGN CHANGE	26-Jul-13
PCN13021	51730-002	DESIGN CHANGE	26-Jul-13
PCN13021	51730-003	DESIGN CHANGE	26-Jul-13
PCN13021	51730-004	DESIGN CHANGE	26-Jul-13
PCN13021	51730-005	DESIGN CHANGE	26-Jul-13
PCN13021	51730-006	DESIGN CHANGE	26-Jul-13
PCN13021	51730-006LF	DESIGN CHANGE	26-Jul-13

PCN13021	51730-007	DESIGN CHANGE	26-Jul-13
PCN13021	51730-007LF	DESIGN CHANGE	26-Jul-13
PCN13021	51730-008	DESIGN CHANGE	26-Jul-13
PCN13021	51730-009	DESIGN CHANGE	26-Jul-13
PCN13021	51730-010	DESIGN CHANGE	26-Jul-13
PCN13021	51730-010LF	DESIGN CHANGE	26-Jul-13
PCN13021	51730-011	DESIGN CHANGE	26-Jul-13
PCN13021	51730-012	DESIGN CHANGE	26-Jul-13
PCN13021	51730-013	DESIGN CHANGE	26-Jul-13
PCN13021	51730-014	DESIGN CHANGE	26-Jul-13
PCN13021	51730-014LF	DESIGN CHANGE	26-Jul-13
PCN13021	51730-015	DESIGN CHANGE	26-Jul-13
PCN13021	51730-016	DESIGN CHANGE	26-Jul-13
PCN13021	51730-016LF	DESIGN CHANGE	26-Jul-13
PCN13021	51730-017	DESIGN CHANGE	26-Jul-13
PCN13021	51730-018	DESIGN CHANGE	26-Jul-13
PCN13021	51730-019	DESIGN CHANGE	26-Jul-13
PCN13021	51730-019LF	DESIGN CHANGE	26-Jul-13
PCN13021	51730-020	DESIGN CHANGE	26-Jul-13
PCN13021	51730-021	DESIGN CHANGE	26-Jul-13
PCN13021	51730-022	DESIGN CHANGE	26-Jul-13
PCN13021	51730-023	DESIGN CHANGE	26-Jul-13
PCN13021	51730-023LF	DESIGN CHANGE	26-Jul-13
PCN13021	51730-024	DESIGN CHANGE	26-Jul-13
PCN13021	51730-024LF	DESIGN CHANGE	26-Jul-13
PCN13021	51730-025	DESIGN CHANGE	26-Jul-13
PCN13021	51730-026	DESIGN CHANGE	26-Jul-13
PCN13021	51730-027	DESIGN CHANGE	26-Jul-13
PCN13021	51730-028	DESIGN CHANGE	26-Jul-13
PCN13021	51730-029	DESIGN CHANGE	26-Jul-13
PCN13021	51730-030	DESIGN CHANGE	26-Jul-13
PCN13021	51730-031	DESIGN CHANGE	26-Jul-13
PCN13021	51730-031LF	DESIGN CHANGE	26-Jul-13
PCN13021	51730-032	DESIGN CHANGE	26-Jul-13
PCN13021	51730-032LF	DESIGN CHANGE	26-Jul-13
PCN13021	51730-033	DESIGN CHANGE	26-Jul-13
PCN13021	51730-033LF	DESIGN CHANGE	26-Jul-13
PCN13021	51730-034	DESIGN CHANGE	26-Jul-13
PCN13021	51730-034LF	DESIGN CHANGE	26-Jul-13
PCN13021	51730-035	DESIGN CHANGE	26-Jul-13
PCN13021	51730-036	DESIGN CHANGE	26-Jul-13

PCN13021	51730-037	DESIGN CHANGE	26-Jul-13
PCN13021	51730-038	DESIGN CHANGE	26-Jul-13
PCN13021	51730-039	DESIGN CHANGE	26-Jul-13
PCN13021	51730-040	DESIGN CHANGE	26-Jul-13
PCN13021	51730-041	DESIGN CHANGE	26-Jul-13
PCN13021	51730-042	DESIGN CHANGE	26-Jul-13
PCN13021	51730-042LF	DESIGN CHANGE	26-Jul-13
PCN13021	51730-043	DESIGN CHANGE	26-Jul-13
PCN13021	51730-043LF	DESIGN CHANGE	26-Jul-13
PCN13021	51730-044	DESIGN CHANGE	26-Jul-13
PCN13021	51730-045	DESIGN CHANGE	26-Jul-13
PCN13021	51730-046	DESIGN CHANGE	26-Jul-13
PCN13021	51730-047	DESIGN CHANGE	26-Jul-13
PCN13021	51730-048	DESIGN CHANGE	26-Jul-13
PCN13021	51730-048LF	DESIGN CHANGE	26-Jul-13
PCN13021	51730-049	DESIGN CHANGE	26-Jul-13
PCN13021	51730-050	DESIGN CHANGE	26-Jul-13
PCN13021	51730-051	DESIGN CHANGE	26-Jul-13
PCN13021	51730-052	DESIGN CHANGE	26-Jul-13
PCN13021	51730-053	DESIGN CHANGE	26-Jul-13
PCN13021	51730-054	DESIGN CHANGE	26-Jul-13
PCN13021	51730-054LF	DESIGN CHANGE	26-Jul-13
PCN13021	51730-055	DESIGN CHANGE	26-Jul-13
PCN13021	51730-056	DESIGN CHANGE	26-Jul-13
PCN13021	51730-057	DESIGN CHANGE	26-Jul-13
PCN13021	51730-058	DESIGN CHANGE	26-Jul-13
PCN13021	51730-059	DESIGN CHANGE	26-Jul-13
PCN13021	51730-060	DESIGN CHANGE	26-Jul-13
PCN13021	51730-061	DESIGN CHANGE	26-Jul-13
PCN13021	51730-062	DESIGN CHANGE	26-Jul-13
PCN13021	51730-062LF	DESIGN CHANGE	26-Jul-13
PCN13021	51730-063	DESIGN CHANGE	26-Jul-13
PCN13021	51730-064	DESIGN CHANGE	26-Jul-13
PCN13021	51730-065	DESIGN CHANGE	26-Jul-13
PCN13021	51730-066	DESIGN CHANGE	26-Jul-13
PCN13021	51730-067	DESIGN CHANGE	26-Jul-13
PCN13021	51730-067LF	DESIGN CHANGE	26-Jul-13
PCN13021	51730-068	DESIGN CHANGE	26-Jul-13
PCN13021	51730-069	DESIGN CHANGE	26-Jul-13
PCN13021	51730-070	DESIGN CHANGE	26-Jul-13
PCN13021	51730-070LF	DESIGN CHANGE	26-Jul-13

PCN13021	51730-071	DESIGN CHANGE	26-Jul-13
PCN13021	51730-071LF	DESIGN CHANGE	26-Jul-13
PCN13021	51730-072	DESIGN CHANGE	26-Jul-13
PCN13021	51730-072LF	DESIGN CHANGE	26-Jul-13
PCN13021	51730-073	DESIGN CHANGE	26-Jul-13
PCN13021	51730-073LF	DESIGN CHANGE	26-Jul-13
PCN13021	51730-074	DESIGN CHANGE	26-Jul-13
PCN13021	51730-075	DESIGN CHANGE	26-Jul-13
PCN13021	51730-075LF	DESIGN CHANGE	26-Jul-13
PCN13021	51730-076	DESIGN CHANGE	26-Jul-13
PCN13021	51730-076LF	DESIGN CHANGE	26-Jul-13
PCN13021	51730-077	DESIGN CHANGE	26-Jul-13
PCN13021	51730-078	DESIGN CHANGE	26-Jul-13
PCN13021	51730-079	DESIGN CHANGE	26-Jul-13
PCN13021	51730-079LF	DESIGN CHANGE	26-Jul-13
PCN13021	51730-080	DESIGN CHANGE	26-Jul-13
PCN13021	51730-080LF	DESIGN CHANGE	26-Jul-13
PCN13021	51730-081	DESIGN CHANGE	26-Jul-13
PCN13021	51730-082	DESIGN CHANGE	26-Jul-13
PCN13021	51730-083	DESIGN CHANGE	26-Jul-13
PCN13021	51730-083LF	DESIGN CHANGE	26-Jul-13
PCN13021	51730-084	DESIGN CHANGE	26-Jul-13
PCN13021	51730-085	DESIGN CHANGE	26-Jul-13
PCN13021	51730-085LF	DESIGN CHANGE	26-Jul-13
PCN13021	51730-086	DESIGN CHANGE	26-Jul-13
PCN13021	51730-087	DESIGN CHANGE	26-Jul-13
PCN13021	51730-087LF	DESIGN CHANGE	26-Jul-13
PCN13021	51730-088	DESIGN CHANGE	26-Jul-13
PCN13021	51730-089	DESIGN CHANGE	26-Jul-13
PCN13021	51730-089LF	DESIGN CHANGE	26-Jul-13
PCN13021	51730-090	DESIGN CHANGE	26-Jul-13
PCN13021	51730-090LF	DESIGN CHANGE	26-Jul-13
PCN13021	51730-091	DESIGN CHANGE	26-Jul-13
PCN13021	51730-092	DESIGN CHANGE	26-Jul-13
PCN13021	51730-093	DESIGN CHANGE	26-Jul-13
PCN13021	51730-094	DESIGN CHANGE	26-Jul-13
PCN13021	51730-094LF	DESIGN CHANGE	26-Jul-13
PCN13021	51730-095	DESIGN CHANGE	26-Jul-13
PCN13021	51730-095LF	DESIGN CHANGE	26-Jul-13
PCN13021	51730-096	DESIGN CHANGE	26-Jul-13
PCN13021	51730-096LF	DESIGN CHANGE	26-Jul-13

PCN13021	51730-097	DESIGN CHANGE	26-Jul-13
PCN13021	51730-097LF	DESIGN CHANGE	26-Jul-13
PCN13021	51730-098	DESIGN CHANGE	26-Jul-13
PCN13021	51730-099	DESIGN CHANGE	26-Jul-13
PCN13021	51730-099LF	DESIGN CHANGE	26-Jul-13
PCN13021	51730-100	DESIGN CHANGE	26-Jul-13
PCN13021	51730-100LF	DESIGN CHANGE	26-Jul-13
PCN13021	51730-101	DESIGN CHANGE	26-Jul-13
PCN13021	51730-102	DESIGN CHANGE	26-Jul-13
PCN13021	51730-102LF	DESIGN CHANGE	26-Jul-13
PCN13021	51730-103	DESIGN CHANGE	26-Jul-13
PCN13021	51730-103LF	DESIGN CHANGE	26-Jul-13
PCN13021	51730-104	DESIGN CHANGE	26-Jul-13
PCN13021	51730-105	DESIGN CHANGE	26-Jul-13
PCN13021	51730-106	DESIGN CHANGE	26-Jul-13
PCN13021	51730-107	DESIGN CHANGE	26-Jul-13
PCN13021	51730-107LF	DESIGN CHANGE	26-Jul-13
PCN13021	51730-108	DESIGN CHANGE	26-Jul-13
PCN13021	51730-108LF	DESIGN CHANGE	26-Jul-13
PCN13021	51730-109LF	DESIGN CHANGE	26-Jul-13
PCN13021	51730-110	DESIGN CHANGE	26-Jul-13
PCN13021	51730-110LF	DESIGN CHANGE	26-Jul-13
PCN13021	51730-111	DESIGN CHANGE	26-Jul-13
PCN13021	51730-111LF	DESIGN CHANGE	26-Jul-13
PCN13021	51730-112LF	DESIGN CHANGE	26-Jul-13
PCN13021	51730-114	DESIGN CHANGE	26-Jul-13
PCN13021	51730-114LF	DESIGN CHANGE	26-Jul-13
PCN13021	51730-115	DESIGN CHANGE	26-Jul-13
PCN13021	51730-116LF	DESIGN CHANGE	26-Jul-13
PCN13021	51730-117	DESIGN CHANGE	26-Jul-13
PCN13021	51730-117LF	DESIGN CHANGE	26-Jul-13
PCN13021	51730-118	DESIGN CHANGE	26-Jul-13
PCN13021	51730-119	DESIGN CHANGE	26-Jul-13
PCN13021	51730-119LF	DESIGN CHANGE	26-Jul-13
PCN13021	51730-120LF	DESIGN CHANGE	26-Jul-13
PCN13021	51730-121	DESIGN CHANGE	26-Jul-13
PCN13021	51730-121LF	DESIGN CHANGE	26-Jul-13
PCN13021	51730-122	DESIGN CHANGE	26-Jul-13
PCN13021	51730-122LF	DESIGN CHANGE	26-Jul-13
PCN13021	51730-123LF	DESIGN CHANGE	26-Jul-13
PCN13021	51730-124LF	DESIGN CHANGE	26-Jul-13

PCN13021	51730-126LF	DESIGN CHANGE	26-Jul-13
PCN13021	51730-129LF	DESIGN CHANGE	26-Jul-13
PCN13021	51730-130	DESIGN CHANGE	26-Jul-13
PCN13021	51730-130LF	DESIGN CHANGE	26-Jul-13
PCN13021	51730-132LF	DESIGN CHANGE	26-Jul-13
PCN13021	51730-133LF	DESIGN CHANGE	26-Jul-13
PCN13021	51730-134	DESIGN CHANGE	26-Jul-13
PCN13021	51730-134LF	DESIGN CHANGE	26-Jul-13
PCN13021	51730-135LF	DESIGN CHANGE	26-Jul-13
PCN13021	51730-137LF	DESIGN CHANGE	26-Jul-13
PCN13021	51730-138LF	DESIGN CHANGE	26-Jul-13
PCN13021	51730-139LF	DESIGN CHANGE	26-Jul-13
PCN13021	51730-141LF	DESIGN CHANGE	26-Jul-13
PCN13021	51730-142LF	DESIGN CHANGE	26-Jul-13
PCN13021	51730-143LF	DESIGN CHANGE	26-Jul-13
PCN13021	51730-145LF	DESIGN CHANGE	26-Jul-13
PCN13021	51730-146LF	DESIGN CHANGE	26-Jul-13
PCN13021	51730-147LF	DESIGN CHANGE	26-Jul-13
PCN13021	51730-148LF	DESIGN CHANGE	26-Jul-13
PCN13021	51730-149LF	DESIGN CHANGE	26-Jul-13
PCN13021	51730-150LF	DESIGN CHANGE	26-Jul-13
PCN13021	51730-151LF	DESIGN CHANGE	26-Jul-13
PCN13021	51730-153LF	DESIGN CHANGE	26-Jul-13
PCN13021	51730-154LF	DESIGN CHANGE	26-Jul-13
PCN13021	51730-155LF	DESIGN CHANGE	26-Jul-13
PCN13021	51730-156LF	DESIGN CHANGE	26-Jul-13
PCN13021	51730-157LF	DESIGN CHANGE	26-Jul-13
PCN13021	51730-158LF	DESIGN CHANGE	26-Jul-13
PCN13021	51730-159LF	DESIGN CHANGE	26-Jul-13
PCN13021	51730-161LF	DESIGN CHANGE	26-Jul-13
PCN13021	51730-162LF	DESIGN CHANGE	26-Jul-13
PCN13021	51730-165LF	DESIGN CHANGE	26-Jul-13
PCN13021	51730-166LF	DESIGN CHANGE	26-Jul-13
PCN13021	51730-167LF	DESIGN CHANGE	26-Jul-13
PCN13021	51730-168LF	DESIGN CHANGE	26-Jul-13
PCN13021	51730-169LF	DESIGN CHANGE	26-Jul-13
PCN13021	51730-172LF	DESIGN CHANGE	26-Jul-13
PCN13021	51730-174LF	DESIGN CHANGE	26-Jul-13
PCN13021	51730-175LF	DESIGN CHANGE	26-Jul-13
PCN13021	51730-176	DESIGN CHANGE	26-Jul-13
PCN13021	51730-176LF	DESIGN CHANGE	26-Jul-13



PCN13021	51730-178LF	DESIGN CHANGE	26-Jul-13
PCN13021	51730-179LF	DESIGN CHANGE	26-Jul-13
PCN13021	51730-180LF	DESIGN CHANGE	26-Jul-13
PCN13021	51730-181LF	DESIGN CHANGE	26-Jul-13
PCN13021	51730-183LF	DESIGN CHANGE	26-Jul-13
PCN13021	51730-184LF	DESIGN CHANGE	26-Jul-13
PCN13021	51730-185LF	DESIGN CHANGE	26-Jul-13
PCN13021	51730-186LF	DESIGN CHANGE	26-Jul-13
PCN13021	51730-187LF	DESIGN CHANGE	26-Jul-13
PCN13021	51730-188LF	DESIGN CHANGE	26-Jul-13
PCN13021	51730-189LF	DESIGN CHANGE	26-Jul-13
PCN13021	51730-194LF	DESIGN CHANGE	26-Jul-13
PCN13021	51730-195LF	DESIGN CHANGE	26-Jul-13
PCN13021	51730-196LF	DESIGN CHANGE	26-Jul-13
PCN13021	51730-197LF	DESIGN CHANGE	26-Jul-13
PCN13021	51730-198LF	DESIGN CHANGE	26-Jul-13
PCN13021	51730-199LF	DESIGN CHANGE	26-Jul-13
PCN13021	51730-202LF	DESIGN CHANGE	26-Jul-13
PCN13021	51730-203LF	DESIGN CHANGE	26-Jul-13
PCN13021	51730-216LF	DESIGN CHANGE	26-Jul-13
PCN13021	51731-001	DESIGN CHANGE	26-Jul-13
PCN13021	51731-001LF	DESIGN CHANGE	26-Jul-13
PCN13021	51731-002	DESIGN CHANGE	26-Jul-13
PCN13021	51731-002LF	DESIGN CHANGE	26-Jul-13
PCN13021	51731-003	DESIGN CHANGE	26-Jul-13
PCN13021	51731-004	DESIGN CHANGE	26-Jul-13
PCN13021	51731-005	DESIGN CHANGE	26-Jul-13
PCN13021	51731-006	DESIGN CHANGE	26-Jul-13
PCN13021	51731-006LF	DESIGN CHANGE	26-Jul-13
PCN13021	51731-007	DESIGN CHANGE	26-Jul-13
PCN13021	51731-008	DESIGN CHANGE	26-Jul-13
PCN13021	51731-008LF	DESIGN CHANGE	26-Jul-13
PCN13021	51731-009	DESIGN CHANGE	26-Jul-13
PCN13021	51731-010	DESIGN CHANGE	26-Jul-13
PCN13021	51731-010LF	DESIGN CHANGE	26-Jul-13
PCN13021	51731-011	DESIGN CHANGE	26-Jul-13
PCN13021	51731-011LF	DESIGN CHANGE	26-Jul-13
PCN13021	51731-013	DESIGN CHANGE	26-Jul-13
PCN13021	51731-013LF	DESIGN CHANGE	26-Jul-13
PCN13021	51731-014	DESIGN CHANGE	26-Jul-13
PCN13021	51731-015	DESIGN CHANGE	26-Jul-13

PCN13021	51731-015LF	DESIGN CHANGE	26-Jul-13
PCN13021	51731-016	DESIGN CHANGE	26-Jul-13
PCN13021	51731-017	DESIGN CHANGE	26-Jul-13
PCN13021	51731-018	DESIGN CHANGE	26-Jul-13
PCN13021	51731-018LF	DESIGN CHANGE	26-Jul-13
PCN13021	51731-019	DESIGN CHANGE	26-Jul-13
PCN13021	51731-020	DESIGN CHANGE	26-Jul-13
PCN13021	51731-021	DESIGN CHANGE	26-Jul-13
PCN13021	51731-022	DESIGN CHANGE	26-Jul-13
PCN13021	51731-022LF	DESIGN CHANGE	26-Jul-13
PCN13021	51731-024	DESIGN CHANGE	26-Jul-13
PCN13021	51731-025	DESIGN CHANGE	26-Jul-13
PCN13021	51731-025GLF	DESIGN CHANGE	26-Jul-13
PCN13021	51731-025LF	DESIGN CHANGE	26-Jul-13
PCN13021	51731-026	DESIGN CHANGE	26-Jul-13
PCN13021	51731-027	DESIGN CHANGE	26-Jul-13
PCN13021	51731-027LF	DESIGN CHANGE	26-Jul-13
PCN13021	51731-029	DESIGN CHANGE	26-Jul-13
PCN13021	51731-029LF	DESIGN CHANGE	26-Jul-13
PCN13021	51731-030LF	DESIGN CHANGE	26-Jul-13
PCN13021	51731-031	DESIGN CHANGE	26-Jul-13
PCN13021	51731-032	DESIGN CHANGE	26-Jul-13
PCN13021	51731-032LF	DESIGN CHANGE	26-Jul-13
PCN13021	51731-034	DESIGN CHANGE	26-Jul-13
PCN13021	51731-034LF	DESIGN CHANGE	26-Jul-13
PCN13021	51731-035	DESIGN CHANGE	26-Jul-13
PCN13021	51731-035LF	DESIGN CHANGE	26-Jul-13
PCN13021	51731-036LF	DESIGN CHANGE	26-Jul-13
PCN13021	51731-039LF	DESIGN CHANGE	26-Jul-13
PCN13021	51731-040	DESIGN CHANGE	26-Jul-13
PCN13021	51731-040LF	DESIGN CHANGE	26-Jul-13
PCN13021	51731-042LF	DESIGN CHANGE	26-Jul-13
PCN13021	51731-043LF	DESIGN CHANGE	26-Jul-13
PCN13021	51731-045LF	DESIGN CHANGE	26-Jul-13
PCN13021	51731-046LF	DESIGN CHANGE	26-Jul-13
PCN13021	51731-047LF	DESIGN CHANGE	26-Jul-13
PCN13021	51731-048LF	DESIGN CHANGE	26-Jul-13
PCN13021	51731-049LF	DESIGN CHANGE	26-Jul-13
PCN13021	51731-050LF	DESIGN CHANGE	26-Jul-13
PCN13021	51731-052LF	DESIGN CHANGE	26-Jul-13
PCN13021	51731-055LF	DESIGN CHANGE	26-Jul-13

PCN13021	51731-057LF	DESIGN CHANGE	26-Jul-13
PCN13021	51731-059LF	DESIGN CHANGE	26-Jul-13
PCN13021	51731-060LF	DESIGN CHANGE	26-Jul-13
PCN13021	51731-061LF	DESIGN CHANGE	26-Jul-13
PCN13021	51731-062LF	DESIGN CHANGE	26-Jul-13
PCN13021	51731-063LF	DESIGN CHANGE	26-Jul-13
PCN13021	51731-064LF	DESIGN CHANGE	26-Jul-13
PCN13021	51731-066LF	DESIGN CHANGE	26-Jul-13
PCN13021	51731-068LF	DESIGN CHANGE	26-Jul-13
PCN13021	51731-069LF	DESIGN CHANGE	26-Jul-13
PCN13021	51731-071LF	DESIGN CHANGE	26-Jul-13
PCN13021	51731-072LF	DESIGN CHANGE	26-Jul-13
PCN13021	51731-073LF	DESIGN CHANGE	26-Jul-13
PCN13021	51731-074LF	DESIGN CHANGE	26-Jul-13
PCN13021	51731-076LF	DESIGN CHANGE	26-Jul-13
PCN13021	51731-077LF	DESIGN CHANGE	26-Jul-13
PCN13021	51731-078LF	DESIGN CHANGE	26-Jul-13
PCN13021	51731-079LF	DESIGN CHANGE	26-Jul-13
PCN13021	51731-080LF	DESIGN CHANGE	26-Jul-13
PCN13021	51731-081LF	DESIGN CHANGE	26-Jul-13
PCN13021	51731-082LF	DESIGN CHANGE	26-Jul-13
PCN13021	51731-083LF	DESIGN CHANGE	26-Jul-13
PCN13021	51731-084LF	DESIGN CHANGE	26-Jul-13
PCN13021	51732-002	DESIGN CHANGE	26-Jul-13
PCN13021	51732-003	DESIGN CHANGE	26-Jul-13
PCN13021	51732-003LF	DESIGN CHANGE	26-Jul-13
PCN13021	51732-004	DESIGN CHANGE	26-Jul-13
PCN13021	51732-005	DESIGN CHANGE	26-Jul-13
PCN13021	51732-006	DESIGN CHANGE	26-Jul-13
PCN13021	51732-007	DESIGN CHANGE	26-Jul-13
PCN13021	51732-007LF	DESIGN CHANGE	26-Jul-13
PCN13021	51732-008	DESIGN CHANGE	26-Jul-13
PCN13021	51732-008LF	DESIGN CHANGE	26-Jul-13
PCN13021	51732-009	DESIGN CHANGE	26-Jul-13
PCN13021	51732-010	DESIGN CHANGE	26-Jul-13
PCN13021	51732-011	DESIGN CHANGE	26-Jul-13
PCN13021	51732-011LF	DESIGN CHANGE	26-Jul-13
PCN13021	51732-012	DESIGN CHANGE	26-Jul-13
PCN13021	51732-013	DESIGN CHANGE	26-Jul-13
PCN13021	51732-013LF	DESIGN CHANGE	26-Jul-13
PCN13021	51732-016	DESIGN CHANGE	26-Jul-13

PCN13021	51732-016LF	DESIGN CHANGE	26-Jul-13
PCN13021	51732-017	DESIGN CHANGE	26-Jul-13
PCN13021	51732-018	DESIGN CHANGE	26-Jul-13
PCN13021	51732-019	DESIGN CHANGE	26-Jul-13
PCN13021	51732-019LF	DESIGN CHANGE	26-Jul-13
PCN13021	51732-020	DESIGN CHANGE	26-Jul-13
PCN13021	51732-020LF	DESIGN CHANGE	26-Jul-13
PCN13021	51732-021	DESIGN CHANGE	26-Jul-13
PCN13021	51732-021LF	DESIGN CHANGE	26-Jul-13
PCN13021	51732-022	DESIGN CHANGE	26-Jul-13
PCN13021	51732-022LF	DESIGN CHANGE	26-Jul-13
PCN13021	51732-023	DESIGN CHANGE	26-Jul-13
PCN13021	51732-023LF	DESIGN CHANGE	26-Jul-13
PCN13021	51732-024	DESIGN CHANGE	26-Jul-13
PCN13021	51732-025	DESIGN CHANGE	26-Jul-13
PCN13021	51732-025LF	DESIGN CHANGE	26-Jul-13
PCN13021	51732-026LF	DESIGN CHANGE	26-Jul-13
PCN13021	51732-027	DESIGN CHANGE	26-Jul-13
PCN13021	51732-027LF	DESIGN CHANGE	26-Jul-13
PCN13021	51732-028LF	DESIGN CHANGE	26-Jul-13
PCN13021	51732-029LF	DESIGN CHANGE	26-Jul-13
PCN13021	51732-030	DESIGN CHANGE	26-Jul-13
PCN13021	51732-030LF	DESIGN CHANGE	26-Jul-13
PCN13021	51732-032	DESIGN CHANGE	26-Jul-13
PCN13021	51732-032LF	DESIGN CHANGE	26-Jul-13
PCN13021	51732-033	DESIGN CHANGE	26-Jul-13
PCN13021	51732-033LF	DESIGN CHANGE	26-Jul-13
PCN13021	51732-035LF	DESIGN CHANGE	26-Jul-13
PCN13021	51732-036	DESIGN CHANGE	26-Jul-13
PCN13021	51732-036LF	DESIGN CHANGE	26-Jul-13
PCN13021	51732-037LF	DESIGN CHANGE	26-Jul-13
PCN13021	51732-038LF	DESIGN CHANGE	26-Jul-13
PCN13021	51732-039	DESIGN CHANGE	26-Jul-13
PCN13021	51732-039LF	DESIGN CHANGE	26-Jul-13
PCN13021	51732-043LF	DESIGN CHANGE	26-Jul-13
PCN13021	51732-044LF	DESIGN CHANGE	26-Jul-13
PCN13021	51732-045LF	DESIGN CHANGE	26-Jul-13
PCN13021	51732-048LF	DESIGN CHANGE	26-Jul-13
PCN13021	51732-049LF	DESIGN CHANGE	26-Jul-13
PCN13021	51732-050LF	DESIGN CHANGE	26-Jul-13
PCN13021	51732-052LF	DESIGN CHANGE	26-Jul-13

PCN13021	51732-053LF	DESIGN CHANGE	26-Jul-13
PCN13021	51732-054LF	DESIGN CHANGE	26-Jul-13
PCN13021	51732-056LF	DESIGN CHANGE	26-Jul-13
PCN13021	51732-057LF	DESIGN CHANGE	26-Jul-13
PCN13021	51732-058LF	DESIGN CHANGE	26-Jul-13
PCN13021	51732-061LF	DESIGN CHANGE	26-Jul-13
PCN13021	51732-062LF	DESIGN CHANGE	26-Jul-13
PCN13021	51732-063LF	DESIGN CHANGE	26-Jul-13
PCN13021	51732-064LF	DESIGN CHANGE	26-Jul-13
PCN13021	51732-065LF	DESIGN CHANGE	26-Jul-13
PCN13021	51732-068LF	DESIGN CHANGE	26-Jul-13
PCN13021	51732-070LF	DESIGN CHANGE	26-Jul-13
PCN13021	51732-071LF	DESIGN CHANGE	26-Jul-13
PCN13021	51732-074LF	DESIGN CHANGE	26-Jul-13
PCN13021	51732-075LF	DESIGN CHANGE	26-Jul-13
PCN13021	51732-076LF	DESIGN CHANGE	26-Jul-13
PCN13021	51732-077LF	DESIGN CHANGE	26-Jul-13
PCN13021	51732-078LF	DESIGN CHANGE	26-Jul-13
PCN13021	51732-079LF	DESIGN CHANGE	26-Jul-13
PCN13021	51734-001	DESIGN CHANGE	26-Jul-13
PCN13021	51734-001LF	DESIGN CHANGE	26-Jul-13
PCN13021	51734-002	DESIGN CHANGE	26-Jul-13
PCN13021	51734-003	DESIGN CHANGE	26-Jul-13
PCN13021	51734-005	DESIGN CHANGE	26-Jul-13
PCN13021	51734-006LF	DESIGN CHANGE	26-Jul-13
PCN13021	51734-007LF	DESIGN CHANGE	26-Jul-13
PCN13021	51736-001	DESIGN CHANGE	26-Jul-13
PCN13021	51736-001LF	DESIGN CHANGE	26-Jul-13
PCN13021	51736-002	DESIGN CHANGE	26-Jul-13
PCN13021	51736-003	DESIGN CHANGE	26-Jul-13
PCN13021	51736-004	DESIGN CHANGE	26-Jul-13
PCN13021	51736-004LF	DESIGN CHANGE	26-Jul-13
PCN13021	51736-005LF	DESIGN CHANGE	26-Jul-13
PCN13021	51736-006LF	DESIGN CHANGE	26-Jul-13
PCN13021	51736-007LF	DESIGN CHANGE	26-Jul-13
PCN13021	51740-10002412AA	DESIGN CHANGE	26-Jul-13
PCN13021	51740-10003200CA	DESIGN CHANGE	26-Jul-13
PCN13021	51740-10003200CALF	DESIGN CHANGE	26-Jul-13
PCN13021	51740-10003606AA	DESIGN CHANGE	26-Jul-13
PCN13021	51740-10003606AALF	DESIGN CHANGE	26-Jul-13
PCN13021	51740-10004000AA	DESIGN CHANGE	26-Jul-13

PCN13021	51740-10004400CA	DESIGN CHANGE	26-Jul-13
PCN13021	51740-10008410CC	DESIGN CHANGE	26-Jul-13
PCN13021	51740-10014800AA	DESIGN CHANGE	26-Jul-13
PCN13021	51740-10014800AALF	DESIGN CHANGE	26-Jul-13
PCN13021	51740-10014800CC	DESIGN CHANGE	26-Jul-13
PCN13021	51740-10100401AA	DESIGN CHANGE	26-Jul-13
PCN13021	51740-10100401AALF	DESIGN CHANGE	26-Jul-13
PCN13021	51740-10100401CCLF	DESIGN CHANGE	26-Jul-13
PCN13021	51740-10100404CCLF	DESIGN CHANGE	26-Jul-13
PCN13021	51740-10100801AA	DESIGN CHANGE	26-Jul-13
PCN13021	51740-10100801AALF	DESIGN CHANGE	26-Jul-13
PCN13021	51740-10100801CCLF	DESIGN CHANGE	26-Jul-13
PCN13021	51740-10101201AALF	DESIGN CHANGE	26-Jul-13
PCN13021	51740-10101201CA	DESIGN CHANGE	26-Jul-13
PCN13021	51740-10101201CALF	DESIGN CHANGE	26-Jul-13
PCN13021	51740-10101201CC	DESIGN CHANGE	26-Jul-13
PCN13021	51740-10101201CCLF	DESIGN CHANGE	26-Jul-13
PCN13021	51740-10101601AA	DESIGN CHANGE	26-Jul-13
PCN13021	51740-10101601AALF	DESIGN CHANGE	26-Jul-13
PCN13021	51740-10101601CA	DESIGN CHANGE	26-Jul-13
PCN13021	51740-10101601CC	DESIGN CHANGE	26-Jul-13
PCN13021	51740-10101601CCLF	DESIGN CHANGE	26-Jul-13
PCN13021	51740-10101608AALF	DESIGN CHANGE	26-Jul-13
PCN13021	51740-10102001AA	DESIGN CHANGE	26-Jul-13
PCN13021	51740-10102001CCLF	DESIGN CHANGE	26-Jul-13
PCN13021	51740-10102401AA	DESIGN CHANGE	26-Jul-13
PCN13021	51740-10102401AALF	DESIGN CHANGE	26-Jul-13
PCN13021	51740-10102401CA	DESIGN CHANGE	26-Jul-13
PCN13021	51740-10102401CALF	DESIGN CHANGE	26-Jul-13
PCN13021	51740-10102401CC	DESIGN CHANGE	26-Jul-13
PCN13021	51740-10102401CCLF	DESIGN CHANGE	26-Jul-13
PCN13021	51740-10103601AALF	DESIGN CHANGE	26-Jul-13
PCN13021	51740-10104002AALF	DESIGN CHANGE	26-Jul-13
PCN13021	51740-10104801AA	DESIGN CHANGE	26-Jul-13
PCN13021	51740-10104801AALF	DESIGN CHANGE	26-Jul-13
PCN13021	51740-10107201AALF	DESIGN CHANGE	26-Jul-13
PCN13021	51740-10107201ACLF	DESIGN CHANGE	26-Jul-13
PCN13021	51740-10108001AALF	DESIGN CHANGE	26-Jul-13
PCN13021	51740-10112801AALF	DESIGN CHANGE	26-Jul-13
PCN13021	51740-10200402AALF	DESIGN CHANGE	26-Jul-13
PCN13021	51740-10200801AALF	DESIGN CHANGE	26-Jul-13

PCN13021	51740-10200802AALF	DESIGN CHANGE	26-Jul-13
PCN13021	51740-10200802CALF	DESIGN CHANGE	26-Jul-13
PCN13021	51740-10200802CC	DESIGN CHANGE	26-Jul-13
PCN13021	51740-10200802CCLF	DESIGN CHANGE	26-Jul-13
PCN13021	51740-10201200AALF	DESIGN CHANGE	26-Jul-13
PCN13021	51740-10201201CA	DESIGN CHANGE	26-Jul-13
PCN13021	51740-10201202AA	DESIGN CHANGE	26-Jul-13
PCN13021	51740-10201202AALF	DESIGN CHANGE	26-Jul-13
PCN13021	51740-10201202CA	DESIGN CHANGE	26-Jul-13
PCN13021	51740-10201202CALF	DESIGN CHANGE	26-Jul-13
PCN13021	51740-10201202CC	DESIGN CHANGE	26-Jul-13
PCN13021	51740-10201202CCLF	DESIGN CHANGE	26-Jul-13
PCN13021	51740-10201204AA	DESIGN CHANGE	26-Jul-13
PCN13021	51740-10201602AA	DESIGN CHANGE	26-Jul-13
PCN13021	51740-10201602AALF	DESIGN CHANGE	26-Jul-13
PCN13021	51740-10201602CA	DESIGN CHANGE	26-Jul-13
PCN13021	51740-10201602CALF	DESIGN CHANGE	26-Jul-13
PCN13021	51740-10201602CC	DESIGN CHANGE	26-Jul-13
PCN13021	51740-10201602CCLF	DESIGN CHANGE	26-Jul-13
PCN13021	51740-10201604AALF	DESIGN CHANGE	26-Jul-13
PCN13021	51740-10201604CCLF	DESIGN CHANGE	26-Jul-13
PCN13021	51740-10202002AA	DESIGN CHANGE	26-Jul-13
PCN13021	51740-10202002CALF	DESIGN CHANGE	26-Jul-13
PCN13021	51740-10202401CC	DESIGN CHANGE	26-Jul-13
PCN13021	51740-10202402AA	DESIGN CHANGE	26-Jul-13
PCN13021	51740-10202402AALF	DESIGN CHANGE	26-Jul-13
PCN13021	51740-10202402ABLF	DESIGN CHANGE	26-Jul-13
PCN13021	51740-10202402ACLF	DESIGN CHANGE	26-Jul-13
PCN13021	51740-10202402CA	DESIGN CHANGE	26-Jul-13
PCN13021	51740-10202402CALF	DESIGN CHANGE	26-Jul-13
PCN13021	51740-10202402CC	DESIGN CHANGE	26-Jul-13
PCN13021	51740-10202402CCLF	DESIGN CHANGE	26-Jul-13
PCN13021	51740-10202403AA	DESIGN CHANGE	26-Jul-13
PCN13021	51740-10202403AALF	DESIGN CHANGE	26-Jul-13
PCN13021	51740-10202404AA	DESIGN CHANGE	26-Jul-13
PCN13021	51740-10202404AALF	DESIGN CHANGE	26-Jul-13
PCN13021	51740-10202404CALF	DESIGN CHANGE	26-Jul-13
PCN13021	51740-10202404CC	DESIGN CHANGE	26-Jul-13
PCN13021	51740-10202404CCLF	DESIGN CHANGE	26-Jul-13
PCN13021	51740-10202406AA	DESIGN CHANGE	26-Jul-13
PCN13021	51740-10202406CC	DESIGN CHANGE	26-Jul-13

PCN13021	51740-10202406CCLF	DESIGN CHANGE	26-Jul-13
PCN13021	51740-10202408AA	DESIGN CHANGE	26-Jul-13
PCN13021	51740-10202408AALF	DESIGN CHANGE	26-Jul-13
PCN13021	51740-10202408CC	DESIGN CHANGE	26-Jul-13
PCN13021	51740-10202408CCLF	DESIGN CHANGE	26-Jul-13
PCN13021	51740-10203202AA	DESIGN CHANGE	26-Jul-13
PCN13021	51740-10203603AA	DESIGN CHANGE	26-Jul-13
PCN13021	51740-10203604AA	DESIGN CHANGE	26-Jul-13
PCN13021	51740-10204002AALF	DESIGN CHANGE	26-Jul-13
PCN13021	51740-10204802AALF	DESIGN CHANGE	26-Jul-13
PCN13021	51740-10204802CALF	DESIGN CHANGE	26-Jul-13
PCN13021	51740-10204802CC	DESIGN CHANGE	26-Jul-13
PCN13021	51740-10204802CCLF	DESIGN CHANGE	26-Jul-13
PCN13021	51740-10206002CCLF	DESIGN CHANGE	26-Jul-13
PCN13021	51740-10206802AALF	DESIGN CHANGE	26-Jul-13
PCN13021	51740-10207202AALF	DESIGN CHANGE	26-Jul-13
PCN13021	51740-10208002AALF	DESIGN CHANGE	26-Jul-13
PCN13021	51740-10209602AALF	DESIGN CHANGE	26-Jul-13
PCN13021	51740-10210001CC	DESIGN CHANGE	26-Jul-13
PCN13021	51740-10210002AA	DESIGN CHANGE	26-Jul-13
PCN13021	51740-10212402AA	DESIGN CHANGE	26-Jul-13
PCN13021	51740-10300403AA	DESIGN CHANGE	26-Jul-13
PCN13021	51740-10300403AALF	DESIGN CHANGE	26-Jul-13
PCN13021	51740-10300803AA	DESIGN CHANGE	26-Jul-13
PCN13021	51740-10300803AALF	DESIGN CHANGE	26-Jul-13
PCN13021	51740-10300803AB	DESIGN CHANGE	26-Jul-13
PCN13021	51740-10300803CALF	DESIGN CHANGE	26-Jul-13
PCN13021	51740-10300803CC	DESIGN CHANGE	26-Jul-13
PCN13021	51740-10301203AA	DESIGN CHANGE	26-Jul-13
PCN13021	51740-10301203AALF	DESIGN CHANGE	26-Jul-13
PCN13021	51740-10301203CC	DESIGN CHANGE	26-Jul-13
PCN13021	51740-10301602AA	DESIGN CHANGE	26-Jul-13
PCN13021	51740-10301602AALF	DESIGN CHANGE	26-Jul-13
PCN13021	51740-10301603AA	DESIGN CHANGE	26-Jul-13
PCN13021	51740-10301603AALF	DESIGN CHANGE	26-Jul-13
PCN13021	51740-10301603CALF	DESIGN CHANGE	26-Jul-13
PCN13021	51740-10301603CC	DESIGN CHANGE	26-Jul-13
PCN13021	51740-10301604AALF	DESIGN CHANGE	26-Jul-13
PCN13021	51740-10301608AA	DESIGN CHANGE	26-Jul-13
PCN13021	51740-10301611CA	DESIGN CHANGE	26-Jul-13
PCN13021	51740-10302003AALF	DESIGN CHANGE	26-Jul-13



PCN13021	51740-10302003CA	DESIGN CHANGE	26-Jul-13
PCN13021	51740-10302003CALF	DESIGN CHANGE	26-Jul-13
PCN13021	51740-10302003CC	DESIGN CHANGE	26-Jul-13
PCN13021	51740-10302005AA	DESIGN CHANGE	26-Jul-13
PCN13021	51740-10302005AALF	DESIGN CHANGE	26-Jul-13
PCN13021	51740-10302402CCLF	DESIGN CHANGE	26-Jul-13
PCN13021	51740-10302403AA	DESIGN CHANGE	26-Jul-13
PCN13021	51740-10302403AALF	DESIGN CHANGE	26-Jul-13
PCN13021	51740-10302403ABLF	DESIGN CHANGE	26-Jul-13
PCN13021	51740-10302403CA	DESIGN CHANGE	26-Jul-13
PCN13021	51740-10302403CALF	DESIGN CHANGE	26-Jul-13
PCN13021	51740-10302403CC	DESIGN CHANGE	26-Jul-13
PCN13021	51740-10302403CCLF	DESIGN CHANGE	26-Jul-13
PCN13021	51740-10302404AA	DESIGN CHANGE	26-Jul-13
PCN13021	51740-10302404AALF	DESIGN CHANGE	26-Jul-13
PCN13021	51740-10302404CCLF	DESIGN CHANGE	26-Jul-13
PCN13021	51740-10302405CALF	DESIGN CHANGE	26-Jul-13
PCN13021	51740-10302406AA	DESIGN CHANGE	26-Jul-13
PCN13021	51740-10302406AALF	DESIGN CHANGE	26-Jul-13
PCN13021	51740-10302408ACLF	DESIGN CHANGE	26-Jul-13
PCN13021	51740-10303203AALF	DESIGN CHANGE	26-Jul-13
PCN13021	51740-10303603AA	DESIGN CHANGE	26-Jul-13
PCN13021	51740-10303603AALF	DESIGN CHANGE	26-Jul-13
PCN13021	51740-10303603CCLF	DESIGN CHANGE	26-Jul-13
PCN13021	51740-10304003CALF	DESIGN CHANGE	26-Jul-13
PCN13021	51740-10304803AALF	DESIGN CHANGE	26-Jul-13
PCN13021	51740-10306402AALF	DESIGN CHANGE	26-Jul-13
PCN13021	51740-10312803AA	DESIGN CHANGE	26-Jul-13
PCN13021	51740-10312803AALF	DESIGN CHANGE	26-Jul-13
PCN13021	51740-10312806AA	DESIGN CHANGE	26-Jul-13
PCN13021	51740-10400404CC	DESIGN CHANGE	26-Jul-13
PCN13021	51740-10400404CCLF	DESIGN CHANGE	26-Jul-13
PCN13021	51740-10400804AA	DESIGN CHANGE	26-Jul-13
PCN13021	51740-10400804AALF	DESIGN CHANGE	26-Jul-13
PCN13021	51740-10400804CA	DESIGN CHANGE	26-Jul-13
PCN13021	51740-10400804CALF	DESIGN CHANGE	26-Jul-13
PCN13021	51740-10401202AALF	DESIGN CHANGE	26-Jul-13
PCN13021	51740-10401204AA	DESIGN CHANGE	26-Jul-13
PCN13021	51740-10401204AALF	DESIGN CHANGE	26-Jul-13
PCN13021	51740-10401204CA	DESIGN CHANGE	26-Jul-13
PCN13021	51740-10401204CCLF	DESIGN CHANGE	26-Jul-13

PCN13021	51740-10401602AA	DESIGN CHANGE	26-Jul-13
PCN13021	51740-10401602AALF	DESIGN CHANGE	26-Jul-13
PCN13021	51740-10401602ACLF	DESIGN CHANGE	26-Jul-13
PCN13021	51740-10401602CA	DESIGN CHANGE	26-Jul-13
PCN13021	51740-10401602CALF	DESIGN CHANGE	26-Jul-13
PCN13021	51740-10401602CCLF	DESIGN CHANGE	26-Jul-13
PCN13021	51740-10401603AA	DESIGN CHANGE	26-Jul-13
PCN13021	51740-10401603AALF	DESIGN CHANGE	26-Jul-13
PCN13021	51740-10401603CCLF	DESIGN CHANGE	26-Jul-13
PCN13021	51740-10401604AALF	DESIGN CHANGE	26-Jul-13
PCN13021	51740-10401604ABLF	DESIGN CHANGE	26-Jul-13
PCN13021	51740-10401604ACLF	DESIGN CHANGE	26-Jul-13
PCN13021	51740-10401604CCLF	DESIGN CHANGE	26-Jul-13
PCN13021	51740-10402002AA	DESIGN CHANGE	26-Jul-13
PCN13021	51740-10402002AALF	DESIGN CHANGE	26-Jul-13
PCN13021	51740-10402002CC	DESIGN CHANGE	26-Jul-13
PCN13021	51740-10402003AALF	DESIGN CHANGE	26-Jul-13
PCN13021	51740-10402004AA	DESIGN CHANGE	26-Jul-13
PCN13021	51740-10402004CC	DESIGN CHANGE	26-Jul-13
PCN13021	51740-10402004CCLF	DESIGN CHANGE	26-Jul-13
PCN13021	51740-10402402AA	DESIGN CHANGE	26-Jul-13
PCN13021	51740-10402402AALF	DESIGN CHANGE	26-Jul-13
PCN13021	51740-10402402CALF	DESIGN CHANGE	26-Jul-13
PCN13021	51740-10402402CC	DESIGN CHANGE	26-Jul-13
PCN13021	51740-10402402CCLF	DESIGN CHANGE	26-Jul-13
PCN13021	51740-10402403AALF	DESIGN CHANGE	26-Jul-13
PCN13021	51740-10402403CALF	DESIGN CHANGE	26-Jul-13
PCN13021	51740-10402404AA	DESIGN CHANGE	26-Jul-13
PCN13021	51740-10402404AALF	DESIGN CHANGE	26-Jul-13
PCN13021	51740-10402404ACLF	DESIGN CHANGE	26-Jul-13
PCN13021	51740-10402404CA	DESIGN CHANGE	26-Jul-13
PCN13021	51740-10402404CALF	DESIGN CHANGE	26-Jul-13
PCN13021	51740-10402404CC	DESIGN CHANGE	26-Jul-13
PCN13021	51740-10402404CCLF	DESIGN CHANGE	26-Jul-13
PCN13021	51740-10402406CC	DESIGN CHANGE	26-Jul-13
PCN13021	51740-10402406CCLF	DESIGN CHANGE	26-Jul-13
PCN13021	51740-10402408AA	DESIGN CHANGE	26-Jul-13
PCN13021	51740-10402408CC	DESIGN CHANGE	26-Jul-13
PCN13021	51740-10403204AA	DESIGN CHANGE	26-Jul-13
PCN13021	51740-10403204CA	DESIGN CHANGE	26-Jul-13
PCN13021	51740-10403204CALF	DESIGN CHANGE	26-Jul-13

PCN13021	51740-10403602CC	DESIGN CHANGE	26-Jul-13
PCN13021	51740-10403607AALF	DESIGN CHANGE	26-Jul-13
PCN13021	51740-10404004AA	DESIGN CHANGE	26-Jul-13
PCN13021	51740-10404004CA	DESIGN CHANGE	26-Jul-13
PCN13021	51740-10404004CC	DESIGN CHANGE	26-Jul-13
PCN13021	51740-10404004CCLF	DESIGN CHANGE	26-Jul-13
PCN13021	51740-10404804AA	DESIGN CHANGE	26-Jul-13
PCN13021	51740-10404804AALF	DESIGN CHANGE	26-Jul-13
PCN13021	51740-10404804CA	DESIGN CHANGE	26-Jul-13
PCN13021	51740-10404804CALF	DESIGN CHANGE	26-Jul-13
PCN13021	51740-10405604CCLF	DESIGN CHANGE	26-Jul-13
PCN13021	51740-10410004AA	DESIGN CHANGE	26-Jul-13
PCN13021	51740-10410004AALF	DESIGN CHANGE	26-Jul-13
PCN13021	51740-10500805AA	DESIGN CHANGE	26-Jul-13
PCN13021	51740-10500805AALF	DESIGN CHANGE	26-Jul-13
PCN13021	51740-10500806CC	DESIGN CHANGE	26-Jul-13
PCN13021	51740-10501605ABLF	DESIGN CHANGE	26-Jul-13
PCN13021	51740-10501607AA	DESIGN CHANGE	26-Jul-13
PCN13021	51740-10502002AALF	DESIGN CHANGE	26-Jul-13
PCN13021	51740-10502402AA	DESIGN CHANGE	26-Jul-13
PCN13021	51740-10502405AA	DESIGN CHANGE	26-Jul-13
PCN13021	51740-10502405AALF	DESIGN CHANGE	26-Jul-13
PCN13021	51740-10502405CA	DESIGN CHANGE	26-Jul-13
PCN13021	51740-10502405CALF	DESIGN CHANGE	26-Jul-13
PCN13021	51740-10502405CC	DESIGN CHANGE	26-Jul-13
PCN13021	51740-10502405CCLF	DESIGN CHANGE	26-Jul-13
PCN13021	51740-10502406AA	DESIGN CHANGE	26-Jul-13
PCN13021	51740-10503206AA	DESIGN CHANGE	26-Jul-13
PCN13021	51740-10503606AA	DESIGN CHANGE	26-Jul-13
PCN13021	51740-10503606AALF	DESIGN CHANGE	26-Jul-13
PCN13021	51740-10504004AA	DESIGN CHANGE	26-Jul-13
PCN13021	51740-10504004AALF	DESIGN CHANGE	26-Jul-13
PCN13021	51740-10600806AALF	DESIGN CHANGE	26-Jul-13
PCN13021	51740-10601209AALF	DESIGN CHANGE	26-Jul-13
PCN13021	51740-10601209CA	DESIGN CHANGE	26-Jul-13
PCN13021	51740-10601209CALF	DESIGN CHANGE	26-Jul-13
PCN13021	51740-10601602AALF	DESIGN CHANGE	26-Jul-13
PCN13021	51740-10601603AC	DESIGN CHANGE	26-Jul-13
PCN13021	51740-10602004AA	DESIGN CHANGE	26-Jul-13
PCN13021	51740-10602004AALF	DESIGN CHANGE	26-Jul-13
PCN13021	51740-10602004CC	DESIGN CHANGE	26-Jul-13

PCN13021	51740-10602005ABLF	DESIGN CHANGE	26-Jul-13
PCN13021	51740-10602006AA	DESIGN CHANGE	26-Jul-13
PCN13021	51740-10602006CC	DESIGN CHANGE	26-Jul-13
PCN13021	51740-10602403AA	DESIGN CHANGE	26-Jul-13
PCN13021	51740-10602405AA	DESIGN CHANGE	26-Jul-13
PCN13021	51740-10602405CC	DESIGN CHANGE	26-Jul-13
PCN13021	51740-10602405CCLF	DESIGN CHANGE	26-Jul-13
PCN13021	51740-10602406AA	DESIGN CHANGE	26-Jul-13
PCN13021	51740-10602406AALF	DESIGN CHANGE	26-Jul-13
PCN13021	51740-10602406CA	DESIGN CHANGE	26-Jul-13
PCN13021	51740-10602406CALF	DESIGN CHANGE	26-Jul-13
PCN13021	51740-10602406CC	DESIGN CHANGE	26-Jul-13
PCN13021	51740-10602806AC	DESIGN CHANGE	26-Jul-13
PCN13021	51740-10602806CC	DESIGN CHANGE	26-Jul-13
PCN13021	51740-10602806CCLF	DESIGN CHANGE	26-Jul-13
PCN13021	51740-10602807AA	DESIGN CHANGE	26-Jul-13
PCN13021	51740-10602807AALF	DESIGN CHANGE	26-Jul-13
PCN13021	51740-10602808CALF	DESIGN CHANGE	26-Jul-13
PCN13021	51740-10603207CC	DESIGN CHANGE	26-Jul-13
PCN13021	51740-10603207CCLF	DESIGN CHANGE	26-Jul-13
PCN13021	51740-10605206CA	DESIGN CHANGE	26-Jul-13
PCN13021	51740-10700807AA	DESIGN CHANGE	26-Jul-13
PCN13021	51740-10701607AA	DESIGN CHANGE	26-Jul-13
PCN13021	51740-10701607AALF	DESIGN CHANGE	26-Jul-13
PCN13021	51740-10702406AA	DESIGN CHANGE	26-Jul-13
PCN13021	51740-10702406AALF	DESIGN CHANGE	26-Jul-13
PCN13021	51740-10702407AC	DESIGN CHANGE	26-Jul-13
PCN13021	51740-10702407CCLF	DESIGN CHANGE	26-Jul-13
PCN13021	51740-10702807AA	DESIGN CHANGE	26-Jul-13
PCN13021	51740-10702807AALF	DESIGN CHANGE	26-Jul-13
PCN13021	51740-10702809AA	DESIGN CHANGE	26-Jul-13
PCN13021	51740-10703206AA	DESIGN CHANGE	26-Jul-13
PCN13021	51740-10703206AALF	DESIGN CHANGE	26-Jul-13
PCN13021	51740-10703206ACLF	DESIGN CHANGE	26-Jul-13
PCN13021	51740-10703206CALF	DESIGN CHANGE	26-Jul-13
PCN13021	51740-10703206CC	DESIGN CHANGE	26-Jul-13
PCN13021	51740-10703206CCLF	DESIGN CHANGE	26-Jul-13
PCN13021	51740-10703207CCLF	DESIGN CHANGE	26-Jul-13
PCN13021	51740-10801208CC	DESIGN CHANGE	26-Jul-13
PCN13021	51740-10801208CCLF	DESIGN CHANGE	26-Jul-13
PCN13021	51740-10801604CCLF	DESIGN CHANGE	26-Jul-13

PCN13021	51740-10802400CCLF	DESIGN CHANGE	26-Jul-13
PCN13021	51740-10802407AA	DESIGN CHANGE	26-Jul-13
PCN13021	51740-10802407CC	DESIGN CHANGE	26-Jul-13
PCN13021	51740-10802408AA	DESIGN CHANGE	26-Jul-13
PCN13021	51740-10802408AALF	DESIGN CHANGE	26-Jul-13
PCN13021	51740-10802408CALF	DESIGN CHANGE	26-Jul-13
PCN13021	51740-10802808AA	DESIGN CHANGE	26-Jul-13
PCN13021	51740-10803208AA	DESIGN CHANGE	26-Jul-13
PCN13021	51740-10803208CCLF	DESIGN CHANGE	26-Jul-13
PCN13021	51740-10901206AA	DESIGN CHANGE	26-Jul-13
PCN13021	51740-10901206CA	DESIGN CHANGE	26-Jul-13
PCN13021	51740-10901209CCLF	DESIGN CHANGE	26-Jul-13
PCN13021	51740-10903204AA	DESIGN CHANGE	26-Jul-13
PCN13021	51740-10903204AALF	DESIGN CHANGE	26-Jul-13
PCN13021	51740-10909209AC	DESIGN CHANGE	26-Jul-13
PCN13021	51740-11002006AALF	DESIGN CHANGE	26-Jul-13
PCN13021	51740-11004410CCLF	DESIGN CHANGE	26-Jul-13
PCN13021	51740-11008410AA	DESIGN CHANGE	26-Jul-13
PCN13021	51740-11008410AALF	DESIGN CHANGE	26-Jul-13
PCN13021	51740-11008410CC	DESIGN CHANGE	26-Jul-13
PCN13021	51740-11102003AA	DESIGN CHANGE	26-Jul-13
PCN13021	51740-11102003AALF	DESIGN CHANGE	26-Jul-13
PCN13021	51740-11102003CA	DESIGN CHANGE	26-Jul-13
PCN13021	51740-11102003CALF	DESIGN CHANGE	26-Jul-13
PCN13021	51740-11102003CC	DESIGN CHANGE	26-Jul-13
PCN13021	51740-11102003CCLF	DESIGN CHANGE	26-Jul-13
PCN13021	51740-11102005AA	DESIGN CHANGE	26-Jul-13
PCN13021	51740-11202002AA	DESIGN CHANGE	26-Jul-13
PCN13021	51741-10000404AA	DESIGN CHANGE	26-Jul-13
PCN13021	51741-10000404AALF	DESIGN CHANGE	26-Jul-13
PCN13021	51741-10000404CCLF	DESIGN CHANGE	26-Jul-13
PCN13021	51741-10000406AA	DESIGN CHANGE	26-Jul-13
PCN13021	51741-10000406AALF	DESIGN CHANGE	26-Jul-13
PCN13021	51741-10000802CCLF	DESIGN CHANGE	26-Jul-13
PCN13021	51741-10000803AALF	DESIGN CHANGE	26-Jul-13
PCN13021	51741-10000804AA	DESIGN CHANGE	26-Jul-13
PCN13021	51741-10000804AALF	DESIGN CHANGE	26-Jul-13
PCN13021	51741-10000804CCLF	DESIGN CHANGE	26-Jul-13
PCN13021	51741-10000806CC	DESIGN CHANGE	26-Jul-13
PCN13021	51741-10000807CC	DESIGN CHANGE	26-Jul-13
PCN13021	51741-10000807CCLF	DESIGN CHANGE	26-Jul-13

PCN13021	51741-10000808AA	DESIGN CHANGE	26-Jul-13
PCN13021	51741-10000808CC	DESIGN CHANGE	26-Jul-13
PCN13021	51741-10000810AA	DESIGN CHANGE	26-Jul-13
PCN13021	51741-10000810AALF	DESIGN CHANGE	26-Jul-13
PCN13021	51741-10000810CC	DESIGN CHANGE	26-Jul-13
PCN13021	51741-10000810CCLF	DESIGN CHANGE	26-Jul-13
PCN13021	51741-10000812CALF	DESIGN CHANGE	26-Jul-13
PCN13021	51741-10001202AALF	DESIGN CHANGE	26-Jul-13
PCN13021	51741-10001202CCLF	DESIGN CHANGE	26-Jul-13
PCN13021	51741-10001204AALF	DESIGN CHANGE	26-Jul-13
PCN13021	51741-10001204CALF	DESIGN CHANGE	26-Jul-13
PCN13021	51741-10001204CC	DESIGN CHANGE	26-Jul-13
PCN13021	51741-10001204CCLF	DESIGN CHANGE	26-Jul-13
PCN13021	51741-10001206AALF	DESIGN CHANGE	26-Jul-13
PCN13021	51741-10001206ABLF	DESIGN CHANGE	26-Jul-13
PCN13021	51741-10001206ACLF	DESIGN CHANGE	26-Jul-13
PCN13021	51741-10001206CCLF	DESIGN CHANGE	26-Jul-13
PCN13021	51741-10001208AALF	DESIGN CHANGE	26-Jul-13
PCN13021	51741-10001218AALF	DESIGN CHANGE	26-Jul-13
PCN13021	51741-10001602AALF	DESIGN CHANGE	26-Jul-13
PCN13021	51741-10001602CCLF	DESIGN CHANGE	26-Jul-13
PCN13021	51741-10001604AA	DESIGN CHANGE	26-Jul-13
PCN13021	51741-10001604AALF	DESIGN CHANGE	26-Jul-13
PCN13021	51741-10001604AC	DESIGN CHANGE	26-Jul-13
PCN13021	51741-10001604CALF	DESIGN CHANGE	26-Jul-13
PCN13021	51741-10001604CC	DESIGN CHANGE	26-Jul-13
PCN13021	51741-10001604CCLF	DESIGN CHANGE	26-Jul-13
PCN13021	51741-10001605CCLF	DESIGN CHANGE	26-Jul-13
PCN13021	51741-10001607CCLF	DESIGN CHANGE	26-Jul-13
PCN13021	51741-10001608AALF	DESIGN CHANGE	26-Jul-13
PCN13021	51741-10001608AC	DESIGN CHANGE	26-Jul-13
PCN13021	51741-10001608CC	DESIGN CHANGE	26-Jul-13
PCN13021	51741-10001608CCLF	DESIGN CHANGE	26-Jul-13
PCN13021	51741-10001609CC	DESIGN CHANGE	26-Jul-13
PCN13021	51741-10001616AALF	DESIGN CHANGE	26-Jul-13
PCN13021	51741-10002001AALF	DESIGN CHANGE	26-Jul-13
PCN13021	51741-10002004AALF	DESIGN CHANGE	26-Jul-13
PCN13021	51741-10002004CCLF	DESIGN CHANGE	26-Jul-13
PCN13021	51741-10002006AALF	DESIGN CHANGE	26-Jul-13
PCN13021	51741-10002006CALF	DESIGN CHANGE	26-Jul-13
PCN13021	51741-10002007AA	DESIGN CHANGE	26-Jul-13

PCN13021	51741-10002402CC	DESIGN CHANGE	26-Jul-13
PCN13021	51741-10002403AA	DESIGN CHANGE	26-Jul-13
PCN13021	51741-10002403CCLF	DESIGN CHANGE	26-Jul-13
PCN13021	51741-10002404AA	DESIGN CHANGE	26-Jul-13
PCN13021	51741-10002404AALF	DESIGN CHANGE	26-Jul-13
PCN13021	51741-10002404CC	DESIGN CHANGE	26-Jul-13
PCN13021	51741-10002404CCLF	DESIGN CHANGE	26-Jul-13
PCN13021	51741-10002405AA	DESIGN CHANGE	26-Jul-13
PCN13021	51741-10002405AC	DESIGN CHANGE	26-Jul-13
PCN13021	51741-10002405CC	DESIGN CHANGE	26-Jul-13
PCN13021	51741-10002406AA	DESIGN CHANGE	26-Jul-13
PCN13021	51741-10002406AALF	DESIGN CHANGE	26-Jul-13
PCN13021	51741-10002406AB	DESIGN CHANGE	26-Jul-13
PCN13021	51741-10002406AC	DESIGN CHANGE	26-Jul-13
PCN13021	51741-10002406ACLF	DESIGN CHANGE	26-Jul-13
PCN13021	51741-10002406CA	DESIGN CHANGE	26-Jul-13
PCN13021	51741-10002406CALF	DESIGN CHANGE	26-Jul-13
PCN13021	51741-10002406CC	DESIGN CHANGE	26-Jul-13
PCN13021	51741-10002406CCLF	DESIGN CHANGE	26-Jul-13
PCN13021	51741-10002407AA	DESIGN CHANGE	26-Jul-13
PCN13021	51741-10002407AALF	DESIGN CHANGE	26-Jul-13
PCN13021	51741-10002407CC	DESIGN CHANGE	26-Jul-13
PCN13021	51741-10002408AA	DESIGN CHANGE	26-Jul-13
PCN13021	51741-10002408AALF	DESIGN CHANGE	26-Jul-13
PCN13021	51741-10002408CC	DESIGN CHANGE	26-Jul-13
PCN13021	51741-10002408CCLF	DESIGN CHANGE	26-Jul-13
PCN13021	51741-10002409AALF	DESIGN CHANGE	26-Jul-13
PCN13021	51741-10002410CA	DESIGN CHANGE	26-Jul-13
PCN13021	51741-10002410CALF	DESIGN CHANGE	26-Jul-13
PCN13021	51741-10002410CC	DESIGN CHANGE	26-Jul-13
PCN13021	51741-10002410CCLF	DESIGN CHANGE	26-Jul-13
PCN13021	51741-10002411CCLF	DESIGN CHANGE	26-Jul-13
PCN13021	51741-10002412CCLF	DESIGN CHANGE	26-Jul-13
PCN13021	51741-10002414AA	DESIGN CHANGE	26-Jul-13
PCN13021	51741-10002414AALF	DESIGN CHANGE	26-Jul-13
PCN13021	51741-10002414CC	DESIGN CHANGE	26-Jul-13
PCN13021	51741-10002414CCLF	DESIGN CHANGE	26-Jul-13
PCN13021	51741-10002415AA	DESIGN CHANGE	26-Jul-13
PCN13021	51741-10002806CCLF	DESIGN CHANGE	26-Jul-13
PCN13021	51741-10002808CCLF	DESIGN CHANGE	26-Jul-13
PCN13021	51741-10003202AA	DESIGN CHANGE	26-Jul-13

PCN13021	51741-10003202CC	DESIGN CHANGE	26-Jul-13
PCN13021	51741-10003202CCLF	DESIGN CHANGE	26-Jul-13
PCN13021	51741-10003204CCLF	DESIGN CHANGE	26-Jul-13
PCN13021	51741-10003206CCLF	DESIGN CHANGE	26-Jul-13
PCN13021	51741-10003208CC	DESIGN CHANGE	26-Jul-13
PCN13021	51741-10003208CCLF	DESIGN CHANGE	26-Jul-13
PCN13021	51741-10003211AALF	DESIGN CHANGE	26-Jul-13
PCN13021	51741-10003214AA	DESIGN CHANGE	26-Jul-13
PCN13021	51741-10003214AALF	DESIGN CHANGE	26-Jul-13
PCN13021	51741-10003220AALF	DESIGN CHANGE	26-Jul-13
PCN13021	51741-10003603AA	DESIGN CHANGE	26-Jul-13
PCN13021	51741-10003605CALF	DESIGN CHANGE	26-Jul-13
PCN13021	51741-10003615AA	DESIGN CHANGE	26-Jul-13
PCN13021	51741-10004007ACLF	DESIGN CHANGE	26-Jul-13
PCN13021	51741-10004802AALF	DESIGN CHANGE	26-Jul-13
PCN13021	51741-10004803AALF	DESIGN CHANGE	26-Jul-13
PCN13021	51741-10004808CCLF	DESIGN CHANGE	26-Jul-13
PCN13021	51741-10006017AA	DESIGN CHANGE	26-Jul-13
PCN13021	51741-10006020AC	DESIGN CHANGE	26-Jul-13
PCN13021	51741-10006403AALF	DESIGN CHANGE	26-Jul-13
PCN13021	51741-10009220AA	DESIGN CHANGE	26-Jul-13
PCN13021	51741-10009220CC	DESIGN CHANGE	26-Jul-13
PCN13021	51741-10012002CALF	DESIGN CHANGE	26-Jul-13
PCN13021	51742-10002404AALF	DESIGN CHANGE	26-Jul-13
PCN13021	51742-10002406AALF	DESIGN CHANGE	26-Jul-13
PCN13021	51742-10103600AA	DESIGN CHANGE	26-Jul-13
PCN13021	51742-10103600CC	DESIGN CHANGE	26-Jul-13
PCN13021	51742-10103600CCLF	DESIGN CHANGE	26-Jul-13
PCN13021	51742-10200400AALF	DESIGN CHANGE	26-Jul-13
PCN13021	51742-10200400CC	DESIGN CHANGE	26-Jul-13
PCN13021	51742-10200800AALF	DESIGN CHANGE	26-Jul-13
PCN13021	51742-10200800CCLF	DESIGN CHANGE	26-Jul-13
PCN13021	51742-10201200AA	DESIGN CHANGE	26-Jul-13
PCN13021	51742-10201200AALF	DESIGN CHANGE	26-Jul-13
PCN13021	51742-10201200ABLF	DESIGN CHANGE	26-Jul-13
PCN13021	51742-10201200CC	DESIGN CHANGE	26-Jul-13
PCN13021	51742-10201200CCLF	DESIGN CHANGE	26-Jul-13
PCN13021	51742-10201600AA	DESIGN CHANGE	26-Jul-13
PCN13021	51742-10201600AALF	DESIGN CHANGE	26-Jul-13
PCN13021	51742-10201600CALF	DESIGN CHANGE	26-Jul-13
PCN13021	51742-10202400AA	DESIGN CHANGE	26-Jul-13



PCN13021	51742-10202400AALF	DESIGN CHANGE	26-Jul-13
PCN13021	51742-10202400CALF	DESIGN CHANGE	26-Jul-13
PCN13021	51742-10202400CC	DESIGN CHANGE	26-Jul-13
PCN13021	51742-10202400CCLF	DESIGN CHANGE	26-Jul-13
PCN13021	51742-10203600AALF	DESIGN CHANGE	26-Jul-13
PCN13021	51742-10203600AC	DESIGN CHANGE	26-Jul-13
PCN13021	51742-10204000AALF	DESIGN CHANGE	26-Jul-13
PCN13021	51742-10204800CC	DESIGN CHANGE	26-Jul-13
PCN13021	51742-10204800CCLF	DESIGN CHANGE	26-Jul-13
PCN13021	51742-10207600AALF	DESIGN CHANGE	26-Jul-13
PCN13021	51742-10214400CCLF	DESIGN CHANGE	26-Jul-13
PCN13021	51742-10301600AALF	DESIGN CHANGE	26-Jul-13
PCN13021	51742-10302400AA	DESIGN CHANGE	26-Jul-13
PCN13021	51742-10302400CC	DESIGN CHANGE	26-Jul-13
PCN13021	51742-10303200CCLF	DESIGN CHANGE	26-Jul-13
PCN13021	51742-10400800AALF	DESIGN CHANGE	26-Jul-13
PCN13021	51742-10401200AA	DESIGN CHANGE	26-Jul-13
PCN13021	51742-10401200AALF	DESIGN CHANGE	26-Jul-13
PCN13021	51742-10401200CALF	DESIGN CHANGE	26-Jul-13
PCN13021	51742-10401200CC	DESIGN CHANGE	26-Jul-13
PCN13021	51742-10401200CCLF	DESIGN CHANGE	26-Jul-13
PCN13021	51742-10401600AA	DESIGN CHANGE	26-Jul-13
PCN13021	51742-10401600AALF	DESIGN CHANGE	26-Jul-13
PCN13021	51742-10401600CA	DESIGN CHANGE	26-Jul-13
PCN13021	51742-10401600CALF	DESIGN CHANGE	26-Jul-13
PCN13021	51742-10402000AALF	DESIGN CHANGE	26-Jul-13
PCN13021	51742-10402000CCLF	DESIGN CHANGE	26-Jul-13
PCN13021	51742-10402400AA	DESIGN CHANGE	26-Jul-13
PCN13021	51742-10402400AALF	DESIGN CHANGE	26-Jul-13
PCN13021	51742-10402400CA	DESIGN CHANGE	26-Jul-13
PCN13021	51742-10402400CC	DESIGN CHANGE	26-Jul-13
PCN13021	51742-10402400CCLF	DESIGN CHANGE	26-Jul-13
PCN13021	51742-10403200AA	DESIGN CHANGE	26-Jul-13
PCN13021	51742-10403200AALF	DESIGN CHANGE	26-Jul-13
PCN13021	51742-10403200CALF	DESIGN CHANGE	26-Jul-13
PCN13021	51742-10403200CCLF	DESIGN CHANGE	26-Jul-13
PCN13021	51742-10403600CC	DESIGN CHANGE	26-Jul-13
PCN13021	51742-10406000AA	DESIGN CHANGE	26-Jul-13
PCN13021	51742-10406000AALF	DESIGN CHANGE	26-Jul-13
PCN13021	51742-10407200CCLF	DESIGN CHANGE	26-Jul-13
PCN13021	51742-10411200CC	DESIGN CHANGE	26-Jul-13

PCN13021	51742-10501600AA	DESIGN CHANGE	26-Jul-13
PCN13021	51742-10501600AALF	DESIGN CHANGE	26-Jul-13
PCN13021	51742-10502400AA	DESIGN CHANGE	26-Jul-13
PCN13021	51742-10502400AALF	DESIGN CHANGE	26-Jul-13
PCN13021	51742-10502400CC	DESIGN CHANGE	26-Jul-13
PCN13021	51742-10600400CC	DESIGN CHANGE	26-Jul-13
PCN13021	51742-10600800AA	DESIGN CHANGE	26-Jul-13
PCN13021	51742-10600800AALF	DESIGN CHANGE	26-Jul-13
PCN13021	51742-10600800CC	DESIGN CHANGE	26-Jul-13
PCN13021	51742-10600800CCLF	DESIGN CHANGE	26-Jul-13
PCN13021	51742-10601200AALF	DESIGN CHANGE	26-Jul-13
PCN13021	51742-10601200CCLF	DESIGN CHANGE	26-Jul-13
PCN13021	51742-10601600AALF	DESIGN CHANGE	26-Jul-13
PCN13021	51742-10601600CCLF	DESIGN CHANGE	26-Jul-13
PCN13021	51742-10602000AA	DESIGN CHANGE	26-Jul-13
PCN13021	51742-10602000AALF	DESIGN CHANGE	26-Jul-13
PCN13021	51742-10602000AC	DESIGN CHANGE	26-Jul-13
PCN13021	51742-10602000CA	DESIGN CHANGE	26-Jul-13
PCN13021	51742-10602000CALF	DESIGN CHANGE	26-Jul-13
PCN13021	51742-10602000CC	DESIGN CHANGE	26-Jul-13
PCN13021	51742-10602000CCLF	DESIGN CHANGE	26-Jul-13
PCN13021	51742-10602400AALF	DESIGN CHANGE	26-Jul-13
PCN13021	51742-10602400ABLF	DESIGN CHANGE	26-Jul-13
PCN13021	51742-10602400ACLF	DESIGN CHANGE	26-Jul-13
PCN13021	51742-10602400CALF	DESIGN CHANGE	26-Jul-13
PCN13021	51742-10602400CC	DESIGN CHANGE	26-Jul-13
PCN13021	51742-10602400CCLF	DESIGN CHANGE	26-Jul-13
PCN13021	51742-10603200AA	DESIGN CHANGE	26-Jul-13
PCN13021	51742-10603200AALF	DESIGN CHANGE	26-Jul-13
PCN13021	51742-10603600AA	DESIGN CHANGE	26-Jul-13
PCN13021	51742-10603600AALF	DESIGN CHANGE	26-Jul-13
PCN13021	51742-10604000AALF	DESIGN CHANGE	26-Jul-13
PCN13021	51742-10610400AALF	DESIGN CHANGE	26-Jul-13
PCN13021	51742-10702400AA	DESIGN CHANGE	26-Jul-13
PCN13021	51742-10702400AALF	DESIGN CHANGE	26-Jul-13
PCN13021	51742-10704000ACLF	DESIGN CHANGE	26-Jul-13
PCN13021	51742-10704000CC	DESIGN CHANGE	26-Jul-13
PCN13021	51742-10800800AALF	DESIGN CHANGE	26-Jul-13
PCN13021	51742-10801200AA	DESIGN CHANGE	26-Jul-13
PCN13021	51742-10801200AALF	DESIGN CHANGE	26-Jul-13
PCN13021	51742-10801600CALF	DESIGN CHANGE	26-Jul-13

PCN13021	51742-10801600CC	DESIGN CHANGE	26-Jul-13
PCN13021	51742-10801600CCLF	DESIGN CHANGE	26-Jul-13
PCN13021	51742-10802400AA	DESIGN CHANGE	26-Jul-13
PCN13021	51742-10802400AALF	DESIGN CHANGE	26-Jul-13
PCN13021	51742-10802400AC	DESIGN CHANGE	26-Jul-13
PCN13021	51742-10802400ACLF	DESIGN CHANGE	26-Jul-13
PCN13021	51742-10802400CALF	DESIGN CHANGE	26-Jul-13
PCN13021	51742-10802400CC	DESIGN CHANGE	26-Jul-13
PCN13021	51742-10802400CCLF	DESIGN CHANGE	26-Jul-13
PCN13021	51742-10802800CALF	DESIGN CHANGE	26-Jul-13
PCN13021	51742-10804400AALF	DESIGN CHANGE	26-Jul-13
PCN13021	51742-10901600CC	DESIGN CHANGE	26-Jul-13
PCN13021	51742-10901600CCLF	DESIGN CHANGE	26-Jul-13
PCN13021	51742-10902000AALF	DESIGN CHANGE	26-Jul-13
PCN13021	51742-11000400CC	DESIGN CHANGE	26-Jul-13
PCN13021	51742-11001200AA	DESIGN CHANGE	26-Jul-13
PCN13021	51742-11001600CALF	DESIGN CHANGE	26-Jul-13
PCN13021	51742-11002400AALF	DESIGN CHANGE	26-Jul-13
PCN13021	51742-11002400CA	DESIGN CHANGE	26-Jul-13
PCN13021	51742-11002400CCLF	DESIGN CHANGE	26-Jul-13
PCN13021	51742-11003200CCLF	DESIGN CHANGE	26-Jul-13
PCN13021	51742-11201200AA	DESIGN CHANGE	26-Jul-13
PCN13021	51742-11201200AALF	DESIGN CHANGE	26-Jul-13
PCN13021	51742-11201200CCLF	DESIGN CHANGE	26-Jul-13
PCN13021	51742-11201600AA	DESIGN CHANGE	26-Jul-13
PCN13021	51742-11202000AALF	DESIGN CHANGE	26-Jul-13
PCN13021	51742-11202000CC	DESIGN CHANGE	26-Jul-13
PCN13021	51742-11202000CCLF	DESIGN CHANGE	26-Jul-13
PCN13021	51742-11202400CCLF	DESIGN CHANGE	26-Jul-13
PCN13021	51742-11402400CC	DESIGN CHANGE	26-Jul-13
PCN13021	51742-11402400CCLF	DESIGN CHANGE	26-Jul-13
PCN13021	51742-11403200AALF	DESIGN CHANGE	26-Jul-13
PCN13021	51742-12001200AALF	DESIGN CHANGE	26-Jul-13
PCN13021	51742-12002000CC	DESIGN CHANGE	26-Jul-13
PCN13021	51742-12002000CCLF	DESIGN CHANGE	26-Jul-13
PCN13021	51742-12002400CALF	DESIGN CHANGE	26-Jul-13
PCN13021	51742-12002400CC	DESIGN CHANGE	26-Jul-13
PCN13021	51742-G0403200AALF	DESIGN CHANGE	26-Jul-13
PCN13021	51744-10014800A0	DESIGN CHANGE	26-Jul-13
PCN13021	51744-10014800C0	DESIGN CHANGE	26-Jul-13
PCN13021	51744-10102401A0	DESIGN CHANGE	26-Jul-13

PCN13021	51744-10200402AOLF	DESIGN CHANGE	26-Jul-13
PCN13021	51744-10202402A0	DESIGN CHANGE	26-Jul-13
PCN13021	51744-10202402AOLF	DESIGN CHANGE	26-Jul-13
PCN13021	51744-10202402C0	DESIGN CHANGE	26-Jul-13
PCN13021	51744-10203202A0	DESIGN CHANGE	26-Jul-13
PCN13021	51744-10301203AOLF	DESIGN CHANGE	26-Jul-13
PCN13021	51744-10301203COLF	DESIGN CHANGE	26-Jul-13
PCN13021	51744-10301608AOLF	DESIGN CHANGE	26-Jul-13
PCN13021	51744-10301611AOLF	DESIGN CHANGE	26-Jul-13
PCN13021	51744-10302004C0	DESIGN CHANGE	26-Jul-13
PCN13021	51744-10302403C0	DESIGN CHANGE	26-Jul-13
PCN13021	51744-10302403COLF	DESIGN CHANGE	26-Jul-13
PCN13021	51744-10302803C0	DESIGN CHANGE	26-Jul-13
PCN13021	51744-10401204C0	DESIGN CHANGE	26-Jul-13
PCN13021	51744-10402404C0	DESIGN CHANGE	26-Jul-13
PCN13021	51744-10402410C0	DESIGN CHANGE	26-Jul-13
PCN13021	51744-10601204A0	DESIGN CHANGE	26-Jul-13
PCN13021	51744-10601204AOLF	DESIGN CHANGE	26-Jul-13
PCN13021	51744-10700807A0	DESIGN CHANGE	26-Jul-13
PCN13021	51744-11001210AOLF	DESIGN CHANGE	26-Jul-13
PCN13021	51745-10002006AOLF	DESIGN CHANGE	26-Jul-13
PCN13021	51745-10002406AOLF	DESIGN CHANGE	26-Jul-13
PCN13021	51745-10014804AOLF	DESIGN CHANGE	26-Jul-13
PCN13021	51746-10102000A0	DESIGN CHANGE	26-Jul-13
PCN13021	51746-10200800A0	DESIGN CHANGE	26-Jul-13
PCN13021	51746-10200800AOLF	DESIGN CHANGE	26-Jul-13
PCN13021	51746-10201600A0	DESIGN CHANGE	26-Jul-13
PCN13021	51746-10201600AOLF	DESIGN CHANGE	26-Jul-13
PCN13021	51746-10207200AOLF	DESIGN CHANGE	26-Jul-13
PCN13021	51746-10300800AOLF	DESIGN CHANGE	26-Jul-13
PCN13021	51746-10400800AOLF	DESIGN CHANGE	26-Jul-13
PCN13021	51746-10402400A0	DESIGN CHANGE	26-Jul-13
PCN13021	51746-10402400C0	DESIGN CHANGE	26-Jul-13
PCN13021	51746-10402400COLF	DESIGN CHANGE	26-Jul-13
PCN13021	51746-10505200AOLF	DESIGN CHANGE	26-Jul-13
PCN13021	51746-10602000AOLF	DESIGN CHANGE	26-Jul-13
PCN13021	51746-10802400C0	DESIGN CHANGE	26-Jul-13
PCN13021	51746-11001200C0	DESIGN CHANGE	26-Jul-13
PCN13021	51746-11001200COLF	DESIGN CHANGE	26-Jul-13
PCN13021	51746-11002400C0	DESIGN CHANGE	26-Jul-13
PCN13021	51746-11301200C0	DESIGN CHANGE	26-Jul-13

PCN13021	51750-002	DESIGN CHANGE	26-Jul-13
PCN13021	51750-002LF	DESIGN CHANGE	26-Jul-13
PCN13021	51750-004	DESIGN CHANGE	26-Jul-13
PCN13021	51750-005	DESIGN CHANGE	26-Jul-13
PCN13021	51750-006	DESIGN CHANGE	26-Jul-13
PCN13021	51750-007	DESIGN CHANGE	26-Jul-13
PCN13021	51750-008	DESIGN CHANGE	26-Jul-13
PCN13021	51750-008LF	DESIGN CHANGE	26-Jul-13
PCN13021	51750-009	DESIGN CHANGE	26-Jul-13
PCN13021	51750-010	DESIGN CHANGE	26-Jul-13
PCN13021	51750-011	DESIGN CHANGE	26-Jul-13
PCN13021	51750-011LF	DESIGN CHANGE	26-Jul-13
PCN13021	51750-012	DESIGN CHANGE	26-Jul-13
PCN13021	51750-013	DESIGN CHANGE	26-Jul-13
PCN13021	51750-014	DESIGN CHANGE	26-Jul-13
PCN13021	51750-014LF	DESIGN CHANGE	26-Jul-13
PCN13021	51750-018	DESIGN CHANGE	26-Jul-13
PCN13021	51750-019	DESIGN CHANGE	26-Jul-13
PCN13021	51750-020	DESIGN CHANGE	26-Jul-13
PCN13021	51750-021	DESIGN CHANGE	26-Jul-13
PCN13021	51750-022	DESIGN CHANGE	26-Jul-13
PCN13021	51750-022LF	DESIGN CHANGE	26-Jul-13
PCN13021	51750-024	DESIGN CHANGE	26-Jul-13
PCN13021	51750-025	DESIGN CHANGE	26-Jul-13
PCN13021	51750-026	DESIGN CHANGE	26-Jul-13
PCN13021	51750-027	DESIGN CHANGE	26-Jul-13
PCN13021	51750-028	DESIGN CHANGE	26-Jul-13
PCN13021	51750-028GLF	DESIGN CHANGE	26-Jul-13
PCN13021	51750-028LF	DESIGN CHANGE	26-Jul-13
PCN13021	51750-029	DESIGN CHANGE	26-Jul-13
PCN13021	51750-030	DESIGN CHANGE	26-Jul-13
PCN13021	51750-031	DESIGN CHANGE	26-Jul-13
PCN13021	51750-031LF	DESIGN CHANGE	26-Jul-13
PCN13021	51750-032	DESIGN CHANGE	26-Jul-13
PCN13021	51750-033	DESIGN CHANGE	26-Jul-13
PCN13021	51750-033LF	DESIGN CHANGE	26-Jul-13
PCN13021	51750-034	DESIGN CHANGE	26-Jul-13
PCN13021	51750-035	DESIGN CHANGE	26-Jul-13
PCN13021	51750-036	DESIGN CHANGE	26-Jul-13
PCN13021	51750-036LF	DESIGN CHANGE	26-Jul-13
PCN13021	51750-037	DESIGN CHANGE	26-Jul-13

PCN13021	51750-038	DESIGN CHANGE	26-Jul-13
PCN13021	51750-038LF	DESIGN CHANGE	26-Jul-13
PCN13021	51750-039	DESIGN CHANGE	26-Jul-13
PCN13021	51750-040	DESIGN CHANGE	26-Jul-13
PCN13021	51750-041	DESIGN CHANGE	26-Jul-13
PCN13021	51750-042	DESIGN CHANGE	26-Jul-13
PCN13021	51750-043	DESIGN CHANGE	26-Jul-13
PCN13021	51750-043LF	DESIGN CHANGE	26-Jul-13
PCN13021	51750-044	DESIGN CHANGE	26-Jul-13
PCN13021	51750-044LF	DESIGN CHANGE	26-Jul-13
PCN13021	51750-045	DESIGN CHANGE	26-Jul-13
PCN13021	51750-046	DESIGN CHANGE	26-Jul-13
PCN13021	51750-046LF	DESIGN CHANGE	26-Jul-13
PCN13021	51750-047	DESIGN CHANGE	26-Jul-13
PCN13021	51750-048	DESIGN CHANGE	26-Jul-13
PCN13021	51750-048LF	DESIGN CHANGE	26-Jul-13
PCN13021	51750-049	DESIGN CHANGE	26-Jul-13
PCN13021	51750-049LF	DESIGN CHANGE	26-Jul-13
PCN13021	51750-050	DESIGN CHANGE	26-Jul-13
PCN13021	51750-051	DESIGN CHANGE	26-Jul-13
PCN13021	51750-052	DESIGN CHANGE	26-Jul-13
PCN13021	51750-052LF	DESIGN CHANGE	26-Jul-13
PCN13021	51750-053	DESIGN CHANGE	26-Jul-13
PCN13021	51750-054	DESIGN CHANGE	26-Jul-13
PCN13021	51750-055	DESIGN CHANGE	26-Jul-13
PCN13021	51750-056	DESIGN CHANGE	26-Jul-13
PCN13021	51750-056LF	DESIGN CHANGE	26-Jul-13
PCN13021	51750-057	DESIGN CHANGE	26-Jul-13
PCN13021	51750-057LF	DESIGN CHANGE	26-Jul-13
PCN13021	51750-058	DESIGN CHANGE	26-Jul-13
PCN13021	51750-059	DESIGN CHANGE	26-Jul-13
PCN13021	51750-059LF	DESIGN CHANGE	26-Jul-13
PCN13021	51750-060	DESIGN CHANGE	26-Jul-13
PCN13021	51750-061	DESIGN CHANGE	26-Jul-13
PCN13021	51750-062	DESIGN CHANGE	26-Jul-13
PCN13021	51750-062LF	DESIGN CHANGE	26-Jul-13
PCN13021	51750-063	DESIGN CHANGE	26-Jul-13
PCN13021	51750-064	DESIGN CHANGE	26-Jul-13
PCN13021	51750-065	DESIGN CHANGE	26-Jul-13
PCN13021	51750-065LF	DESIGN CHANGE	26-Jul-13
PCN13021	51750-066	DESIGN CHANGE	26-Jul-13

PCN13021	51750-066LF	DESIGN CHANGE	26-Jul-13
PCN13021	51750-067LF	DESIGN CHANGE	26-Jul-13
PCN13021	51750-068	DESIGN CHANGE	26-Jul-13
PCN13021	51750-069	DESIGN CHANGE	26-Jul-13
PCN13021	51750-070	DESIGN CHANGE	26-Jul-13
PCN13021	51750-070LF	DESIGN CHANGE	26-Jul-13
PCN13021	51750-071	DESIGN CHANGE	26-Jul-13
PCN13021	51750-071LF	DESIGN CHANGE	26-Jul-13
PCN13021	51750-072	DESIGN CHANGE	26-Jul-13
PCN13021	51750-072LF	DESIGN CHANGE	26-Jul-13
PCN13021	51750-073	DESIGN CHANGE	26-Jul-13
PCN13021	51750-073LF	DESIGN CHANGE	26-Jul-13
PCN13021	51750-075	DESIGN CHANGE	26-Jul-13
PCN13021	51750-075LF	DESIGN CHANGE	26-Jul-13
PCN13021	51750-076	DESIGN CHANGE	26-Jul-13
PCN13021	51750-077	DESIGN CHANGE	26-Jul-13
PCN13021	51750-077LF	DESIGN CHANGE	26-Jul-13
PCN13021	51750-078LF	DESIGN CHANGE	26-Jul-13
PCN13021	51750-079LF	DESIGN CHANGE	26-Jul-13
PCN13021	51750-080	DESIGN CHANGE	26-Jul-13
PCN13021	51750-080LF	DESIGN CHANGE	26-Jul-13
PCN13021	51750-081LF	DESIGN CHANGE	26-Jul-13
PCN13021	51750-083LF	DESIGN CHANGE	26-Jul-13
PCN13021	51750-084LF	DESIGN CHANGE	26-Jul-13
PCN13021	51750-086LF	DESIGN CHANGE	26-Jul-13
PCN13021	51750-089LF	DESIGN CHANGE	26-Jul-13
PCN13021	51750-092LF	DESIGN CHANGE	26-Jul-13
PCN13021	51750-093LF	DESIGN CHANGE	26-Jul-13
PCN13021	51750-095LF	DESIGN CHANGE	26-Jul-13
PCN13021	51750-096LF	DESIGN CHANGE	26-Jul-13
PCN13021	51750-097LF	DESIGN CHANGE	26-Jul-13
PCN13021	51750-098LF	DESIGN CHANGE	26-Jul-13
PCN13021	51750-099LF	DESIGN CHANGE	26-Jul-13
PCN13021	51750-101LF	DESIGN CHANGE	26-Jul-13
PCN13021	51750-102LF	DESIGN CHANGE	26-Jul-13
PCN13021	51750-104LF	DESIGN CHANGE	26-Jul-13
PCN13021	51750-105	DESIGN CHANGE	26-Jul-13
PCN13021	51750-105LF	DESIGN CHANGE	26-Jul-13
PCN13021	51750-106LF	DESIGN CHANGE	26-Jul-13
PCN13021	51750-108LF	DESIGN CHANGE	26-Jul-13
PCN13021	51750-109LF	DESIGN CHANGE	26-Jul-13

PCN13021	51750-110LF	DESIGN CHANGE	26-Jul-13
PCN13021	51750-111LF	DESIGN CHANGE	26-Jul-13
PCN13021	51750-112LF	DESIGN CHANGE	26-Jul-13
PCN13021	51750-114LF	DESIGN CHANGE	26-Jul-13
PCN13021	51750-115LF	DESIGN CHANGE	26-Jul-13
PCN13021	51750-116LF	DESIGN CHANGE	26-Jul-13
PCN13021	51750-118LF	DESIGN CHANGE	26-Jul-13
PCN13021	51750-119LF	DESIGN CHANGE	26-Jul-13
PCN13021	51750-121LF	DESIGN CHANGE	26-Jul-13
PCN13021	51750-122LF	DESIGN CHANGE	26-Jul-13
PCN13021	51751-002	DESIGN CHANGE	26-Jul-13
PCN13021	51751-003	DESIGN CHANGE	26-Jul-13
PCN13021	51751-004	DESIGN CHANGE	26-Jul-13
PCN13021	51751-005	DESIGN CHANGE	26-Jul-13
PCN13021	51751-005LF	DESIGN CHANGE	26-Jul-13
PCN13021	51751-006	DESIGN CHANGE	26-Jul-13
PCN13021	51751-007	DESIGN CHANGE	26-Jul-13
PCN13021	51751-007LF	DESIGN CHANGE	26-Jul-13
PCN13021	51751-008	DESIGN CHANGE	26-Jul-13
PCN13021	51751-009	DESIGN CHANGE	26-Jul-13
PCN13021	51751-010	DESIGN CHANGE	26-Jul-13
PCN13021	51751-011	DESIGN CHANGE	26-Jul-13
PCN13021	51751-011LF	DESIGN CHANGE	26-Jul-13
PCN13021	51751-013	DESIGN CHANGE	26-Jul-13
PCN13021	51751-015	DESIGN CHANGE	26-Jul-13
PCN13021	51751-016LF	DESIGN CHANGE	26-Jul-13
PCN13021	51751-017LF	DESIGN CHANGE	26-Jul-13
PCN13021	51751-018LF	DESIGN CHANGE	26-Jul-13
PCN13021	51751-019LF	DESIGN CHANGE	26-Jul-13
PCN13021	51751-020LF	DESIGN CHANGE	26-Jul-13
PCN13021	51751-023LF	DESIGN CHANGE	26-Jul-13
PCN13021	51751-024LF	DESIGN CHANGE	26-Jul-13
PCN13021	51751-028LF	DESIGN CHANGE	26-Jul-13
PCN13021	51751-029LF	DESIGN CHANGE	26-Jul-13
PCN13021	51751-031LF	DESIGN CHANGE	26-Jul-13
PCN13021	51751-032LF	DESIGN CHANGE	26-Jul-13
PCN13021	51752-002	DESIGN CHANGE	26-Jul-13
PCN13021	51752-004	DESIGN CHANGE	26-Jul-13
PCN13021	51752-004LF	DESIGN CHANGE	26-Jul-13
PCN13021	51752-005	DESIGN CHANGE	26-Jul-13
PCN13021	51752-006	DESIGN CHANGE	26-Jul-13



PCN13021	51752-006LF	DESIGN CHANGE	26-Jul-13
PCN13021	51752-007	DESIGN CHANGE	26-Jul-13
PCN13021	51752-008	DESIGN CHANGE	26-Jul-13
PCN13021	51752-010	DESIGN CHANGE	26-Jul-13
PCN13021	51752-010LF	DESIGN CHANGE	26-Jul-13
PCN13021	51752-011	DESIGN CHANGE	26-Jul-13
PCN13021	51752-011LF	DESIGN CHANGE	26-Jul-13
PCN13021	51752-012	DESIGN CHANGE	26-Jul-13
PCN13021	51752-012LF	DESIGN CHANGE	26-Jul-13
PCN13021	51752-013	DESIGN CHANGE	26-Jul-13
PCN13021	51752-013LF	DESIGN CHANGE	26-Jul-13
PCN13021	51752-017LF	DESIGN CHANGE	26-Jul-13
PCN13021	51752-018LF	DESIGN CHANGE	26-Jul-13
PCN13021	51752-020	DESIGN CHANGE	26-Jul-13
PCN13021	51752-020LF	DESIGN CHANGE	26-Jul-13
PCN13021	51752-021	DESIGN CHANGE	26-Jul-13
PCN13021	51752-021LF	DESIGN CHANGE	26-Jul-13
PCN13021	51752-022	DESIGN CHANGE	26-Jul-13
PCN13021	51752-022LF	DESIGN CHANGE	26-Jul-13
PCN13021	51752-024LF	DESIGN CHANGE	26-Jul-13
PCN13021	51752-025LF	DESIGN CHANGE	26-Jul-13
PCN13021	51752-026LF	DESIGN CHANGE	26-Jul-13
PCN13021	51752-027LF	DESIGN CHANGE	26-Jul-13
PCN13021	51752-028LF	DESIGN CHANGE	26-Jul-13
PCN13021	51752-029LF	DESIGN CHANGE	26-Jul-13
PCN13021	51752-030LF	DESIGN CHANGE	26-Jul-13
PCN13021	51752-032LF	DESIGN CHANGE	26-Jul-13
PCN13021	51752-033LF	DESIGN CHANGE	26-Jul-13
PCN13021	51752-034LF	DESIGN CHANGE	26-Jul-13
PCN13021	51752-035LF	DESIGN CHANGE	26-Jul-13
PCN13021	51752-036LF	DESIGN CHANGE	26-Jul-13
PCN13021	51754-001	DESIGN CHANGE	26-Jul-13
PCN13021	51754-001LF	DESIGN CHANGE	26-Jul-13
PCN13021	51754-002	DESIGN CHANGE	26-Jul-13
PCN13021	51754-002LF	DESIGN CHANGE	26-Jul-13
PCN13021	51754-003	DESIGN CHANGE	26-Jul-13
PCN13021	51754-004	DESIGN CHANGE	26-Jul-13
PCN13021	51754-006	DESIGN CHANGE	26-Jul-13
PCN13021	51756-001LF	DESIGN CHANGE	26-Jul-13
PCN13021	51760-10001204AALF	DESIGN CHANGE	26-Jul-13
PCN13021	51760-10001602AALF	DESIGN CHANGE	26-Jul-13

PCN13021	51760-10001604AA	DESIGN CHANGE	26-Jul-13
PCN13021	51760-10002004AA	DESIGN CHANGE	26-Jul-13
PCN13021	51760-10002004AALF	DESIGN CHANGE	26-Jul-13
PCN13021	51760-10002406AALF	DESIGN CHANGE	26-Jul-13
PCN13021	51760-10002806AA	DESIGN CHANGE	26-Jul-13
PCN13021	51760-10004000AA	DESIGN CHANGE	26-Jul-13
PCN13021	51760-10004802AALF	DESIGN CHANGE	26-Jul-13
PCN13021	51760-10007200AA	DESIGN CHANGE	26-Jul-13
PCN13021	51760-10014800AA	DESIGN CHANGE	26-Jul-13
PCN13021	51760-10014800AB	DESIGN CHANGE	26-Jul-13
PCN13021	51760-10100401AALF	DESIGN CHANGE	26-Jul-13
PCN13021	51760-10100801AALF	DESIGN CHANGE	26-Jul-13
PCN13021	51760-10101201AA	DESIGN CHANGE	26-Jul-13
PCN13021	51760-10101201AALF	DESIGN CHANGE	26-Jul-13
PCN13021	51760-10101201ABLF	DESIGN CHANGE	26-Jul-13
PCN13021	51760-10101601AA	DESIGN CHANGE	26-Jul-13
PCN13021	51760-10101601AALF	DESIGN CHANGE	26-Jul-13
PCN13021	51760-10101601AB	DESIGN CHANGE	26-Jul-13
PCN13021	51760-10101601ABLF	DESIGN CHANGE	26-Jul-13
PCN13021	51760-10102401AA	DESIGN CHANGE	26-Jul-13
PCN13021	51760-10102401AALF	DESIGN CHANGE	26-Jul-13
PCN13021	51760-10102401AB	DESIGN CHANGE	26-Jul-13
PCN13021	51760-10102401CBLF	DESIGN CHANGE	26-Jul-13
PCN13021	51760-10102801AB	DESIGN CHANGE	26-Jul-13
PCN13021	51760-10102801CA	DESIGN CHANGE	26-Jul-13
PCN13021	51760-10102801CB	DESIGN CHANGE	26-Jul-13
PCN13021	51760-10103201AA	DESIGN CHANGE	26-Jul-13
PCN13021	51760-10103201AALF	DESIGN CHANGE	26-Jul-13
PCN13021	51760-10103201AB	DESIGN CHANGE	26-Jul-13
PCN13021	51760-10103201ABLF	DESIGN CHANGE	26-Jul-13
PCN13021	51760-10104001AALF	DESIGN CHANGE	26-Jul-13
PCN13021	51760-10104001ABLF	DESIGN CHANGE	26-Jul-13
PCN13021	51760-10104002AALF	DESIGN CHANGE	26-Jul-13
PCN13021	51760-10104401AALF	DESIGN CHANGE	26-Jul-13
PCN13021	51760-10104801AALF	DESIGN CHANGE	26-Jul-13
PCN13021	51760-10106001AA	DESIGN CHANGE	26-Jul-13
PCN13021	51760-10106001AALF	DESIGN CHANGE	26-Jul-13
PCN13021	51760-10106001ABLF	DESIGN CHANGE	26-Jul-13
PCN13021	51760-10106001BA	DESIGN CHANGE	26-Jul-13
PCN13021	51760-10106001BB	DESIGN CHANGE	26-Jul-13
PCN13021	51760-10106001BBLF	DESIGN CHANGE	26-Jul-13

PCN13021	51760-10106001CBLF	DESIGN CHANGE	26-Jul-13
PCN13021	51760-10106402AALF	DESIGN CHANGE	26-Jul-13
PCN13021	51760-10107201AALF	DESIGN CHANGE	26-Jul-13
PCN13021	51760-10114801AA	DESIGN CHANGE	26-Jul-13
PCN13021	51760-10114801AALF	DESIGN CHANGE	26-Jul-13
PCN13021	51760-10200402AB	DESIGN CHANGE	26-Jul-13
PCN13021	51760-10200402BA	DESIGN CHANGE	26-Jul-13
PCN13021	51760-10200801AALF	DESIGN CHANGE	26-Jul-13
PCN13021	51760-10200802AALF	DESIGN CHANGE	26-Jul-13
PCN13021	51760-10200802ABLF	DESIGN CHANGE	26-Jul-13
PCN13021	51760-10200802CALF	DESIGN CHANGE	26-Jul-13
PCN13021	51760-10200802CB	DESIGN CHANGE	26-Jul-13
PCN13021	51760-10200806AB	DESIGN CHANGE	26-Jul-13
PCN13021	51760-10201202AA	DESIGN CHANGE	26-Jul-13
PCN13021	51760-10201202AALF	DESIGN CHANGE	26-Jul-13
PCN13021	51760-10201202AB	DESIGN CHANGE	26-Jul-13
PCN13021	51760-10201202ABLF	DESIGN CHANGE	26-Jul-13
PCN13021	51760-10201202BB	DESIGN CHANGE	26-Jul-13
PCN13021	51760-10201202CBLF	DESIGN CHANGE	26-Jul-13
PCN13021	51760-10201204AA	DESIGN CHANGE	26-Jul-13
PCN13021	51760-10201602AA	DESIGN CHANGE	26-Jul-13
PCN13021	51760-10201602AALF	DESIGN CHANGE	26-Jul-13
PCN13021	51760-10201602AB	DESIGN CHANGE	26-Jul-13
PCN13021	51760-10201602ABLF	DESIGN CHANGE	26-Jul-13
PCN13021	51760-10201602CBLF	DESIGN CHANGE	26-Jul-13
PCN13021	51760-10202002AA	DESIGN CHANGE	26-Jul-13
PCN13021	51760-10202002AALF	DESIGN CHANGE	26-Jul-13
PCN13021	51760-10202002AB	DESIGN CHANGE	26-Jul-13
PCN13021	51760-10202402AA	DESIGN CHANGE	26-Jul-13
PCN13021	51760-10202402AALF	DESIGN CHANGE	26-Jul-13
PCN13021	51760-10202402AB	DESIGN CHANGE	26-Jul-13
PCN13021	51760-10202402ABLF	DESIGN CHANGE	26-Jul-13
PCN13021	51760-10202402BALF	DESIGN CHANGE	26-Jul-13
PCN13021	51760-10202402BBLF	DESIGN CHANGE	26-Jul-13
PCN13021	51760-10202402CALF	DESIGN CHANGE	26-Jul-13
PCN13021	51760-10202402CB	DESIGN CHANGE	26-Jul-13
PCN13021	51760-10202402CBLF	DESIGN CHANGE	26-Jul-13
PCN13021	51760-10202404AA	DESIGN CHANGE	26-Jul-13
PCN13021	51760-10202404AALF	DESIGN CHANGE	26-Jul-13
PCN13021	51760-10202404CBLF	DESIGN CHANGE	26-Jul-13
PCN13021	51760-10202406AB	DESIGN CHANGE	26-Jul-13

PCN13021	51760-10202814ABLF	DESIGN CHANGE	26-Jul-13
PCN13021	51760-10203200AA	DESIGN CHANGE	26-Jul-13
PCN13021	51760-10203202AA	DESIGN CHANGE	26-Jul-13
PCN13021	51760-10203206AA	DESIGN CHANGE	26-Jul-13
PCN13021	51760-10203206AALF	DESIGN CHANGE	26-Jul-13
PCN13021	51760-10203606AA	DESIGN CHANGE	26-Jul-13
PCN13021	51760-10203606AALF	DESIGN CHANGE	26-Jul-13
PCN13021	51760-10204002AALF	DESIGN CHANGE	26-Jul-13
PCN13021	51760-10204800AALF	DESIGN CHANGE	26-Jul-13
PCN13021	51760-10204802AB	DESIGN CHANGE	26-Jul-13
PCN13021	51760-10206002AALF	DESIGN CHANGE	26-Jul-13
PCN13021	51760-10207202AALF	DESIGN CHANGE	26-Jul-13
PCN13021	51760-10208002AALF	DESIGN CHANGE	26-Jul-13
PCN13021	51760-10209602BALF	DESIGN CHANGE	26-Jul-13
PCN13021	51760-10210002AA	DESIGN CHANGE	26-Jul-13
PCN13021	51760-10210002AALF	DESIGN CHANGE	26-Jul-13
PCN13021	51760-10210002CBLF	DESIGN CHANGE	26-Jul-13
PCN13021	51760-10300403AALF	DESIGN CHANGE	26-Jul-13
PCN13021	51760-10300802AB	DESIGN CHANGE	26-Jul-13
PCN13021	51760-10300803AA	DESIGN CHANGE	26-Jul-13
PCN13021	51760-10300803AALF	DESIGN CHANGE	26-Jul-13
PCN13021	51760-10300803AB	DESIGN CHANGE	26-Jul-13
PCN13021	51760-10300803BB	DESIGN CHANGE	26-Jul-13
PCN13021	51760-10301202AALF	DESIGN CHANGE	26-Jul-13
PCN13021	51760-10301203AA	DESIGN CHANGE	26-Jul-13
PCN13021	51760-10301203AALF	DESIGN CHANGE	26-Jul-13
PCN13021	51760-10301603CBLF	DESIGN CHANGE	26-Jul-13
PCN13021	51760-10301604AALF	DESIGN CHANGE	26-Jul-13
PCN13021	51760-10302003AA	DESIGN CHANGE	26-Jul-13
PCN13021	51760-10302003AALF	DESIGN CHANGE	26-Jul-13
PCN13021	51760-10302003AB	DESIGN CHANGE	26-Jul-13
PCN13021	51760-10302003CBLF	DESIGN CHANGE	26-Jul-13
PCN13021	51760-10302008AA	DESIGN CHANGE	26-Jul-13
PCN13021	51760-10302008AB	DESIGN CHANGE	26-Jul-13
PCN13021	51760-10302403AA	DESIGN CHANGE	26-Jul-13
PCN13021	51760-10302403AALF	DESIGN CHANGE	26-Jul-13
PCN13021	51760-10302403AB	DESIGN CHANGE	26-Jul-13
PCN13021	51760-10302403ABLF	DESIGN CHANGE	26-Jul-13
PCN13021	51760-10302403CBLF	DESIGN CHANGE	26-Jul-13
PCN13021	51760-10302404BB	DESIGN CHANGE	26-Jul-13
PCN13021	51760-10302405AA	DESIGN CHANGE	26-Jul-13

PCN13021	51760-10302801CB	DESIGN CHANGE	26-Jul-13
PCN13021	51760-10302803AALF	DESIGN CHANGE	26-Jul-13
PCN13021	51760-10303203AALF	DESIGN CHANGE	26-Jul-13
PCN13021	51760-10306802AALF	DESIGN CHANGE	26-Jul-13
PCN13021	51760-10312003AB	DESIGN CHANGE	26-Jul-13
PCN13021	51760-10312003ABLF	DESIGN CHANGE	26-Jul-13
PCN13021	51760-10312803ABLF	DESIGN CHANGE	26-Jul-13
PCN13021	51760-10400404AB	DESIGN CHANGE	26-Jul-13
PCN13021	51760-10400804AA	DESIGN CHANGE	26-Jul-13
PCN13021	51760-10400804AALF	DESIGN CHANGE	26-Jul-13
PCN13021	51760-10401204AALF	DESIGN CHANGE	26-Jul-13
PCN13021	51760-10401204AB	DESIGN CHANGE	26-Jul-13
PCN13021	51760-10401204ABLF	DESIGN CHANGE	26-Jul-13
PCN13021	51760-10401602AA	DESIGN CHANGE	26-Jul-13
PCN13021	51760-10401602AALF	DESIGN CHANGE	26-Jul-13
PCN13021	51760-10401602AB	DESIGN CHANGE	26-Jul-13
PCN13021	51760-10401602ABLF	DESIGN CHANGE	26-Jul-13
PCN13021	51760-10401603ABLF	DESIGN CHANGE	26-Jul-13
PCN13021	51760-10401604AALF	DESIGN CHANGE	26-Jul-13
PCN13021	51760-10401604ABLF	DESIGN CHANGE	26-Jul-13
PCN13021	51760-10402002AA	DESIGN CHANGE	26-Jul-13
PCN13021	51760-10402002AALF	DESIGN CHANGE	26-Jul-13
PCN13021	51760-10402004AA	DESIGN CHANGE	26-Jul-13
PCN13021	51760-10402402AA	DESIGN CHANGE	26-Jul-13
PCN13021	51760-10402402AALF	DESIGN CHANGE	26-Jul-13
PCN13021	51760-10402402ABLF	DESIGN CHANGE	26-Jul-13
PCN13021	51760-10402402CALF	DESIGN CHANGE	26-Jul-13
PCN13021	51760-10402402CBLF	DESIGN CHANGE	26-Jul-13
PCN13021	51760-10402403AA	DESIGN CHANGE	26-Jul-13
PCN13021	51760-10402403AALF	DESIGN CHANGE	26-Jul-13
PCN13021	51760-10402404AA	DESIGN CHANGE	26-Jul-13
PCN13021	51760-10402404AALF	DESIGN CHANGE	26-Jul-13
PCN13021	51760-10402404AB	DESIGN CHANGE	26-Jul-13
PCN13021	51760-10402404ABLF	DESIGN CHANGE	26-Jul-13
PCN13021	51760-10402404CB	DESIGN CHANGE	26-Jul-13
PCN13021	51760-10402404CBLF	DESIGN CHANGE	26-Jul-13
PCN13021	51760-10402406AB	DESIGN CHANGE	26-Jul-13
PCN13021	51760-10402406ABLF	DESIGN CHANGE	26-Jul-13
PCN13021	51760-10402408AA	DESIGN CHANGE	26-Jul-13
PCN13021	51760-10402408AALF	DESIGN CHANGE	26-Jul-13
PCN13021	51760-10402804AA	DESIGN CHANGE	26-Jul-13

PCN13021	51760-10402804AALF	DESIGN CHANGE	26-Jul-13
PCN13021	51760-10403204AA	DESIGN CHANGE	26-Jul-13
PCN13021	51760-10403204AALF	DESIGN CHANGE	26-Jul-13
PCN13021	51760-10403204CBLF	DESIGN CHANGE	26-Jul-13
PCN13021	51760-10404004AA	DESIGN CHANGE	26-Jul-13
PCN13021	51760-10404004AALF	DESIGN CHANGE	26-Jul-13
PCN13021	51760-10404004CB	DESIGN CHANGE	26-Jul-13
PCN13021	51760-10404804AALF	DESIGN CHANGE	26-Jul-13
PCN13021	51760-10404804AB	DESIGN CHANGE	26-Jul-13
PCN13021	51760-10404804ABLF	DESIGN CHANGE	26-Jul-13
PCN13021	51760-10404804BB	DESIGN CHANGE	26-Jul-13
PCN13021	51760-10404804BBLF	DESIGN CHANGE	26-Jul-13
PCN13021	51760-10404804CBLF	DESIGN CHANGE	26-Jul-13
PCN13021	51760-10405604AALF	DESIGN CHANGE	26-Jul-13
PCN13021	51760-10405604CBLF	DESIGN CHANGE	26-Jul-13
PCN13021	51760-10412004AALF	DESIGN CHANGE	26-Jul-13
PCN13021	51760-10500805CBLF	DESIGN CHANGE	26-Jul-13
PCN13021	51760-10501205AA	DESIGN CHANGE	26-Jul-13
PCN13021	51760-10502005AA	DESIGN CHANGE	26-Jul-13
PCN13021	51760-10502005AALF	DESIGN CHANGE	26-Jul-13
PCN13021	51760-10502403ABLF	DESIGN CHANGE	26-Jul-13
PCN13021	51760-10502405AA	DESIGN CHANGE	26-Jul-13
PCN13021	51760-10502405AALF	DESIGN CHANGE	26-Jul-13
PCN13021	51760-10502405AB	DESIGN CHANGE	26-Jul-13
PCN13021	51760-10502406AA	DESIGN CHANGE	26-Jul-13
PCN13021	51760-10503205AALF	DESIGN CHANGE	26-Jul-13
PCN13021	51760-10503205CBLF	DESIGN CHANGE	26-Jul-13
PCN13021	51760-10503206AA	DESIGN CHANGE	26-Jul-13
PCN13021	51760-10601604CBLF	DESIGN CHANGE	26-Jul-13
PCN13021	51760-10602005AB	DESIGN CHANGE	26-Jul-13
PCN13021	51760-10602404ABLF	DESIGN CHANGE	26-Jul-13
PCN13021	51760-10602405AA	DESIGN CHANGE	26-Jul-13
PCN13021	51760-10602406CB	DESIGN CHANGE	26-Jul-13
PCN13021	51760-10602406CBLF	DESIGN CHANGE	26-Jul-13
PCN13021	51760-10602408AA	DESIGN CHANGE	26-Jul-13
PCN13021	51760-10602804AA	DESIGN CHANGE	26-Jul-13
PCN13021	51760-10602804AB	DESIGN CHANGE	26-Jul-13
PCN13021	51760-10602804ABLF	DESIGN CHANGE	26-Jul-13
PCN13021	51760-10602806AA	DESIGN CHANGE	26-Jul-13
PCN13021	51760-10602808AA	DESIGN CHANGE	26-Jul-13
PCN13021	51760-10602808AB	DESIGN CHANGE	26-Jul-13

PCN13021	51760-10602808ABLF	DESIGN CHANGE	26-Jul-13
PCN13021	51760-10603204ABLF	DESIGN CHANGE	26-Jul-13
PCN13021	51760-10603206AB	DESIGN CHANGE	26-Jul-13
PCN13021	51760-10606006AA	DESIGN CHANGE	26-Jul-13
PCN13021	51760-10606006AALF	DESIGN CHANGE	26-Jul-13
PCN13021	51760-10702406AA	DESIGN CHANGE	26-Jul-13
PCN13021	51760-10702406AALF	DESIGN CHANGE	26-Jul-13
PCN13021	51760-10702407AA	DESIGN CHANGE	26-Jul-13
PCN13021	51760-10702407AALF	DESIGN CHANGE	26-Jul-13
PCN13021	51760-10702807AA	DESIGN CHANGE	26-Jul-13
PCN13021	51760-10702807AB	DESIGN CHANGE	26-Jul-13
PCN13021	51760-10703206AA	DESIGN CHANGE	26-Jul-13
PCN13021	51760-10703206AALF	DESIGN CHANGE	26-Jul-13
PCN13021	51760-10703207CALF	DESIGN CHANGE	26-Jul-13
PCN13021	51760-10802408AALF	DESIGN CHANGE	26-Jul-13
PCN13021	51760-10803208AA	DESIGN CHANGE	26-Jul-13
PCN13021	51760-10808408AB	DESIGN CHANGE	26-Jul-13
PCN13021	51760-10810008AB	DESIGN CHANGE	26-Jul-13
PCN13021	51760-10810008ABLF	DESIGN CHANGE	26-Jul-13
PCN13021	51760-11002410AA	DESIGN CHANGE	26-Jul-13
PCN13021	51760-11008410AA	DESIGN CHANGE	26-Jul-13
PCN13021	51760-11008410AALF	DESIGN CHANGE	26-Jul-13
PCN13021	51760-11102003AA	DESIGN CHANGE	26-Jul-13
PCN13021	51760-11102003AALF	DESIGN CHANGE	26-Jul-13
PCN13021	51761-10000404AA	DESIGN CHANGE	26-Jul-13
PCN13021	51761-10000404AALF	DESIGN CHANGE	26-Jul-13
PCN13021	51761-10000404ABLF	DESIGN CHANGE	26-Jul-13
PCN13021	51761-10000802AALF	DESIGN CHANGE	26-Jul-13
PCN13021	51761-10000803AALF	DESIGN CHANGE	26-Jul-13
PCN13021	51761-10000804AA	DESIGN CHANGE	26-Jul-13
PCN13021	51761-10000804AALF	DESIGN CHANGE	26-Jul-13
PCN13021	51761-10000806ABLF	DESIGN CHANGE	26-Jul-13
PCN13021	51761-10000810AA	DESIGN CHANGE	26-Jul-13
PCN13021	51761-10000810AALF	DESIGN CHANGE	26-Jul-13
PCN13021	51761-10001202CBLF	DESIGN CHANGE	26-Jul-13
PCN13021	51761-10001204AA	DESIGN CHANGE	26-Jul-13
PCN13021	51761-10001204AALF	DESIGN CHANGE	26-Jul-13
PCN13021	51761-10001204ABLF	DESIGN CHANGE	26-Jul-13
PCN13021	51761-10001204CALF	DESIGN CHANGE	26-Jul-13
PCN13021	51761-10001204CBLF	DESIGN CHANGE	26-Jul-13
PCN13021	51761-10001206ABLF	DESIGN CHANGE	26-Jul-13

PCN13021	51761-10001206CALF	DESIGN CHANGE	26-Jul-13
PCN13021	51761-10001218AALF	DESIGN CHANGE	26-Jul-13
PCN13021	51761-10001218ABLF	DESIGN CHANGE	26-Jul-13
PCN13021	51761-10001602AALF	DESIGN CHANGE	26-Jul-13
PCN13021	51761-10001604AA	DESIGN CHANGE	26-Jul-13
PCN13021	51761-10001604AALF	DESIGN CHANGE	26-Jul-13
PCN13021	51761-10001605AALF	DESIGN CHANGE	26-Jul-13
PCN13021	51761-10001608AA	DESIGN CHANGE	26-Jul-13
PCN13021	51761-10001614AB	DESIGN CHANGE	26-Jul-13
PCN13021	51761-10001616AALF	DESIGN CHANGE	26-Jul-13
PCN13021	51761-10002002BALF	DESIGN CHANGE	26-Jul-13
PCN13021	51761-10002002BBLF	DESIGN CHANGE	26-Jul-13
PCN13021	51761-10002002CBLF	DESIGN CHANGE	26-Jul-13
PCN13021	51761-10002004AA	DESIGN CHANGE	26-Jul-13
PCN13021	51761-10002004AALF	DESIGN CHANGE	26-Jul-13
PCN13021	51761-10002006AA	DESIGN CHANGE	26-Jul-13
PCN13021	51761-10002014AALF	DESIGN CHANGE	26-Jul-13
PCN13021	51761-10002402AA	DESIGN CHANGE	26-Jul-13
PCN13021	51761-10002402AALF	DESIGN CHANGE	26-Jul-13
PCN13021	51761-10002402ABLF	DESIGN CHANGE	26-Jul-13
PCN13021	51761-10002404AA	DESIGN CHANGE	26-Jul-13
PCN13021	51761-10002404AALF	DESIGN CHANGE	26-Jul-13
PCN13021	51761-10002404ABLF	DESIGN CHANGE	26-Jul-13
PCN13021	51761-10002405BA	DESIGN CHANGE	26-Jul-13
PCN13021	51761-10002405BALF	DESIGN CHANGE	26-Jul-13
PCN13021	51761-10002406AA	DESIGN CHANGE	26-Jul-13
PCN13021	51761-10002406AALF	DESIGN CHANGE	26-Jul-13
PCN13021	51761-10002406AB	DESIGN CHANGE	26-Jul-13
PCN13021	51761-10002406ABLF	DESIGN CHANGE	26-Jul-13
PCN13021	51761-10002406BA	DESIGN CHANGE	26-Jul-13
PCN13021	51761-10002406BALF	DESIGN CHANGE	26-Jul-13
PCN13021	51761-10002406BBLF	DESIGN CHANGE	26-Jul-13
PCN13021	51761-10002406CALF	DESIGN CHANGE	26-Jul-13
PCN13021	51761-10002406CB	DESIGN CHANGE	26-Jul-13
PCN13021	51761-10002406CBLF	DESIGN CHANGE	26-Jul-13
PCN13021	51761-10002407AB	DESIGN CHANGE	26-Jul-13
PCN13021	51761-10002407ABLF	DESIGN CHANGE	26-Jul-13
PCN13021	51761-10002408AA	DESIGN CHANGE	26-Jul-13
PCN13021	51761-10002408AALF	DESIGN CHANGE	26-Jul-13
PCN13021	51761-10002408ABLF	DESIGN CHANGE	26-Jul-13
PCN13021	51761-10002410AA	DESIGN CHANGE	26-Jul-13



PCN13021	51761-10002410AALF	DESIGN CHANGE	26-Jul-13
PCN13021	51761-10002410AB	DESIGN CHANGE	26-Jul-13
PCN13021	51761-10002410ABLF	DESIGN CHANGE	26-Jul-13
PCN13021	51761-10002410CBLF	DESIGN CHANGE	26-Jul-13
PCN13021	51761-10002412ABLF	DESIGN CHANGE	26-Jul-13
PCN13021	51761-10002412CALF	DESIGN CHANGE	26-Jul-13
PCN13021	51761-10002414AA	DESIGN CHANGE	26-Jul-13
PCN13021	51761-10002414AB	DESIGN CHANGE	26-Jul-13
PCN13021	51761-10002416AALF	DESIGN CHANGE	26-Jul-13
PCN13021	51761-10002416CBLF	DESIGN CHANGE	26-Jul-13
PCN13021	51761-10002420ABLF	DESIGN CHANGE	26-Jul-13
PCN13021	51761-10002804AALF	DESIGN CHANGE	26-Jul-13
PCN13021	51761-10002806ABLF	DESIGN CHANGE	26-Jul-13
PCN13021	51761-10002806CBLF	DESIGN CHANGE	26-Jul-13
PCN13021	51761-10002808ABLF	DESIGN CHANGE	26-Jul-13
PCN13021	51761-10002812AA	DESIGN CHANGE	26-Jul-13
PCN13021	51761-10003204AALF	DESIGN CHANGE	26-Jul-13
PCN13021	51761-10003204CBLF	DESIGN CHANGE	26-Jul-13
PCN13021	51761-10003206ABLF	DESIGN CHANGE	26-Jul-13
PCN13021	51761-10003208CB	DESIGN CHANGE	26-Jul-13
PCN13021	51761-10003208CBLF	DESIGN CHANGE	26-Jul-13
PCN13021	51761-10003211AALF	DESIGN CHANGE	26-Jul-13
PCN13021	51761-10003212AALF	DESIGN CHANGE	26-Jul-13
PCN13021	51761-10003214AA	DESIGN CHANGE	26-Jul-13
PCN13021	51761-10003214AB	DESIGN CHANGE	26-Jul-13
PCN13021	51761-10003214ABLF	DESIGN CHANGE	26-Jul-13
PCN13021	51761-10003605AALF	DESIGN CHANGE	26-Jul-13
PCN13021	51761-10003607AA	DESIGN CHANGE	26-Jul-13
PCN13021	51761-10004007ABLF	DESIGN CHANGE	26-Jul-13
PCN13021	51761-10004808AB	DESIGN CHANGE	26-Jul-13
PCN13021	51761-10004818AALF	DESIGN CHANGE	26-Jul-13
PCN13021	51761-10005611CBLF	DESIGN CHANGE	26-Jul-13
PCN13021	51761-10006017AB	DESIGN CHANGE	26-Jul-13
PCN13021	51761-10006020AB	DESIGN CHANGE	26-Jul-13
PCN13021	51761-10006402ABLF	DESIGN CHANGE	26-Jul-13
PCN13021	51761-10006408CB	DESIGN CHANGE	26-Jul-13
PCN13021	51761-10006408CBLF	DESIGN CHANGE	26-Jul-13
PCN13021	51761-10006411CBLF	DESIGN CHANGE	26-Jul-13
PCN13021	51761-10007205ABLF	DESIGN CHANGE	26-Jul-13
PCN13021	51761-10009220AA	DESIGN CHANGE	26-Jul-13
PCN13021	51761-10013602AALF	DESIGN CHANGE	26-Jul-13

PCN13021	51762-10002404AALF	DESIGN CHANGE	26-Jul-13
PCN13021	51762-10002410AALF	DESIGN CHANGE	26-Jul-13
PCN13021	51762-10102400AA	DESIGN CHANGE	26-Jul-13
PCN13021	51762-10102400AALF	DESIGN CHANGE	26-Jul-13
PCN13021	51762-10200400AALF	DESIGN CHANGE	26-Jul-13
PCN13021	51762-10201200AB	DESIGN CHANGE	26-Jul-13
PCN13021	51762-10201200ABLF	DESIGN CHANGE	26-Jul-13
PCN13021	51762-10201200BALF	DESIGN CHANGE	26-Jul-13
PCN13021	51762-10201200CBLF	DESIGN CHANGE	26-Jul-13
PCN13021	51762-10201600AA	DESIGN CHANGE	26-Jul-13
PCN13021	51762-10201600AALF	DESIGN CHANGE	26-Jul-13
PCN13021	51762-10202400AA	DESIGN CHANGE	26-Jul-13
PCN13021	51762-10202400AALF	DESIGN CHANGE	26-Jul-13
PCN13021	51762-10202410AA	DESIGN CHANGE	26-Jul-13
PCN13021	51762-10202800CBLF	DESIGN CHANGE	26-Jul-13
PCN13021	51762-10203200AALF	DESIGN CHANGE	26-Jul-13
PCN13021	51762-10203600CB	DESIGN CHANGE	26-Jul-13
PCN13021	51762-10204000AA	DESIGN CHANGE	26-Jul-13
PCN13021	51762-10204000AALF	DESIGN CHANGE	26-Jul-13
PCN13021	51762-10204800AALF	DESIGN CHANGE	26-Jul-13
PCN13021	51762-10303200AALF	DESIGN CHANGE	26-Jul-13
PCN13021	51762-10400400AA	DESIGN CHANGE	26-Jul-13
PCN13021	51762-10400800AA	DESIGN CHANGE	26-Jul-13
PCN13021	51762-10401200AA	DESIGN CHANGE	26-Jul-13
PCN13021	51762-10401200AALF	DESIGN CHANGE	26-Jul-13
PCN13021	51762-10401200ABLF	DESIGN CHANGE	26-Jul-13
PCN13021	51762-10401200CBLF	DESIGN CHANGE	26-Jul-13
PCN13021	51762-10401600AA	DESIGN CHANGE	26-Jul-13
PCN13021	51762-10401600AALF	DESIGN CHANGE	26-Jul-13
PCN13021	51762-10401600AB	DESIGN CHANGE	26-Jul-13
PCN13021	51762-10401600ABLF	DESIGN CHANGE	26-Jul-13
PCN13021	51762-10401600CB	DESIGN CHANGE	26-Jul-13
PCN13021	51762-10402000AALF	DESIGN CHANGE	26-Jul-13
PCN13021	51762-10402000ABLF	DESIGN CHANGE	26-Jul-13
PCN13021	51762-10402400AA	DESIGN CHANGE	26-Jul-13
PCN13021	51762-10402400AALF	DESIGN CHANGE	26-Jul-13
PCN13021	51762-10402400ABLF	DESIGN CHANGE	26-Jul-13
PCN13021	51762-10402400CBLF	DESIGN CHANGE	26-Jul-13
PCN13021	51762-10406000AALF	DESIGN CHANGE	26-Jul-13
PCN13021	51762-10407200CBLF	DESIGN CHANGE	26-Jul-13
PCN13021	51762-10407200CCLF	DESIGN CHANGE	26-Jul-13

PCN13021	51762-10502400CBLF	DESIGN CHANGE	26-Jul-13
PCN13021	51762-10600400AB	DESIGN CHANGE	26-Jul-13
PCN13021	51762-10600800AALF	DESIGN CHANGE	26-Jul-13
PCN13021	51762-10600800CBLF	DESIGN CHANGE	26-Jul-13
PCN13021	51762-10601600AALF	DESIGN CHANGE	26-Jul-13
PCN13021	51762-10601600AB	DESIGN CHANGE	26-Jul-13
PCN13021	51762-10601600CALF	DESIGN CHANGE	26-Jul-13
PCN13021	51762-10602000AA	DESIGN CHANGE	26-Jul-13
PCN13021	51762-10602000AALF	DESIGN CHANGE	26-Jul-13
PCN13021	51762-10602000ABLF	DESIGN CHANGE	26-Jul-13
PCN13021	51762-10602000CBLF	DESIGN CHANGE	26-Jul-13
PCN13021	51762-10602400AALF	DESIGN CHANGE	26-Jul-13
PCN13021	51762-10603200AALF	DESIGN CHANGE	26-Jul-13
PCN13021	51762-10603600AALF	DESIGN CHANGE	26-Jul-13
PCN13021	51762-10603600CALF	DESIGN CHANGE	26-Jul-13
PCN13021	51762-10606000AALF	DESIGN CHANGE	26-Jul-13
PCN13021	51762-10702400AA	DESIGN CHANGE	26-Jul-13
PCN13021	51762-10704000ABLF	DESIGN CHANGE	26-Jul-13
PCN13021	51762-10802400AA	DESIGN CHANGE	26-Jul-13
PCN13021	51762-10802400AALF	DESIGN CHANGE	26-Jul-13
PCN13021	51762-10802400AB	DESIGN CHANGE	26-Jul-13
PCN13021	51762-10802400ABLF	DESIGN CHANGE	26-Jul-13
PCN13021	51762-10802400BBLF	DESIGN CHANGE	26-Jul-13
PCN13021	51762-10802400CB	DESIGN CHANGE	26-Jul-13
PCN13021	51762-10802400CBLF	DESIGN CHANGE	26-Jul-13
PCN13021	51762-10802800ABLF	DESIGN CHANGE	26-Jul-13
PCN13021	51762-10802800CALF	DESIGN CHANGE	26-Jul-13
PCN13021	51762-10803200CB	DESIGN CHANGE	26-Jul-13
PCN13021	51762-10901200ABLF	DESIGN CHANGE	26-Jul-13
PCN13021	51762-10902400AALF	DESIGN CHANGE	26-Jul-13
PCN13021	51762-11000800ABLF	DESIGN CHANGE	26-Jul-13
PCN13021	51762-11001600ABLF	DESIGN CHANGE	26-Jul-13
PCN13021	51762-11002000ABLF	DESIGN CHANGE	26-Jul-13
PCN13021	51762-11002400AALF	DESIGN CHANGE	26-Jul-13
PCN13021	51762-11002400AB	DESIGN CHANGE	26-Jul-13
PCN13021	51762-11002400ABLF	DESIGN CHANGE	26-Jul-13
PCN13021	51762-11002400CBLF	DESIGN CHANGE	26-Jul-13
PCN13021	51762-11002800CBLF	DESIGN CHANGE	26-Jul-13
PCN13021	51762-11102400AALF	DESIGN CHANGE	26-Jul-13
PCN13021	51762-11103200AA	DESIGN CHANGE	26-Jul-13
PCN13021	51762-11103200AALF	DESIGN CHANGE	26-Jul-13

PCN13021	51762-11106400CBLF	DESIGN CHANGE	26-Jul-13
PCN13021	51762-11200800AA	DESIGN CHANGE	26-Jul-13
PCN13021	51762-11202000AALF	DESIGN CHANGE	26-Jul-13
PCN13021	51762-11402400AA	DESIGN CHANGE	26-Jul-13
PCN13021	51762-11402400AALF	DESIGN CHANGE	26-Jul-13
PCN13021	51762-11402400CBLF	DESIGN CHANGE	26-Jul-13
PCN13021	51762-11702800AA	DESIGN CHANGE	26-Jul-13
PCN13021	51762-11804400AALF	DESIGN CHANGE	26-Jul-13
PCN13021	51764-10014800A0	DESIGN CHANGE	26-Jul-13
PCN13021	51764-10100801AOLF	DESIGN CHANGE	26-Jul-13
PCN13021	51764-10114801A0	DESIGN CHANGE	26-Jul-13
PCN13021	51764-10200402AOLF	DESIGN CHANGE	26-Jul-13
PCN13021	51764-10202003A0	DESIGN CHANGE	26-Jul-13
PCN13021	51764-10202402AOLF	DESIGN CHANGE	26-Jul-13
PCN13021	51764-10301203COLF	DESIGN CHANGE	26-Jul-13
PCN13021	51764-10301603A0	DESIGN CHANGE	26-Jul-13
PCN13021	51764-10301608AOLF	DESIGN CHANGE	26-Jul-13
PCN13021	51764-10301611AOLF	DESIGN CHANGE	26-Jul-13
PCN13021	51765-10000808AOLF	DESIGN CHANGE	26-Jul-13
PCN13021	51765-10001604A0	DESIGN CHANGE	26-Jul-13
PCN13021	51765-10002005A0	DESIGN CHANGE	26-Jul-13
PCN13021	51766-10201200AOLF	DESIGN CHANGE	26-Jul-13
PCN13021	51766-10302400A0	DESIGN CHANGE	26-Jul-13
PCN13021	51766-10401200AOLF	DESIGN CHANGE	26-Jul-13
PCN13021	51766-10402400A0	DESIGN CHANGE	26-Jul-13
PCN13021	51766-10402400AOLF	DESIGN CHANGE	26-Jul-13
PCN13021	51766-10502400AOLF	DESIGN CHANGE	26-Jul-13
PCN13021	51766-10502400B0	DESIGN CHANGE	26-Jul-13
PCN13021	51770-001	DESIGN CHANGE	26-Jul-13
PCN13021	51770-001LF	DESIGN CHANGE	26-Jul-13
PCN13021	51770-002	DESIGN CHANGE	26-Jul-13
PCN13021	51770-002LF	DESIGN CHANGE	26-Jul-13
PCN13021	51770-005	DESIGN CHANGE	26-Jul-13
PCN13021	51770-006	DESIGN CHANGE	26-Jul-13
PCN13021	51770-006LF	DESIGN CHANGE	26-Jul-13
PCN13021	51770-007	DESIGN CHANGE	26-Jul-13
PCN13021	51770-008	DESIGN CHANGE	26-Jul-13
PCN13021	51770-009	DESIGN CHANGE	26-Jul-13
PCN13021	51770-010	DESIGN CHANGE	26-Jul-13
PCN13021	51770-011	DESIGN CHANGE	26-Jul-13
PCN13021	51770-012	DESIGN CHANGE	26-Jul-13

PCN13021	51770-013	DESIGN CHANGE	26-Jul-13
PCN13021	51770-014	DESIGN CHANGE	26-Jul-13
PCN13021	51770-014LF	DESIGN CHANGE	26-Jul-13
PCN13021	51770-015	DESIGN CHANGE	26-Jul-13
PCN13021	51770-016	DESIGN CHANGE	26-Jul-13
PCN13021	51770-016LF	DESIGN CHANGE	26-Jul-13
PCN13021	51770-017	DESIGN CHANGE	26-Jul-13
PCN13021	51770-018	DESIGN CHANGE	26-Jul-13
PCN13021	51770-018LF	DESIGN CHANGE	26-Jul-13
PCN13021	51770-019	DESIGN CHANGE	26-Jul-13
PCN13021	51770-020	DESIGN CHANGE	26-Jul-13
PCN13021	51770-021LF	DESIGN CHANGE	26-Jul-13
PCN13021	51770-022	DESIGN CHANGE	26-Jul-13
PCN13021	51770-022LF	DESIGN CHANGE	26-Jul-13
PCN13021	51770-023	DESIGN CHANGE	26-Jul-13
PCN13021	51770-023LF	DESIGN CHANGE	26-Jul-13
PCN13021	51770-024LF	DESIGN CHANGE	26-Jul-13
PCN13021	51770-025LF	DESIGN CHANGE	26-Jul-13
PCN13021	51770-026	DESIGN CHANGE	26-Jul-13
PCN13021	51770-026LF	DESIGN CHANGE	26-Jul-13
PCN13021	51770-027	DESIGN CHANGE	26-Jul-13
PCN13021	51770-027LF	DESIGN CHANGE	26-Jul-13
PCN13021	51770-029LF	DESIGN CHANGE	26-Jul-13
PCN13021	51770-030	DESIGN CHANGE	26-Jul-13
PCN13021	51770-030LF	DESIGN CHANGE	26-Jul-13
PCN13021	51770-032LF	DESIGN CHANGE	26-Jul-13
PCN13021	51770-034LF	DESIGN CHANGE	26-Jul-13
PCN13021	51770-035LF	DESIGN CHANGE	26-Jul-13
PCN13021	51770-041LF	DESIGN CHANGE	26-Jul-13
PCN13021	51770-042LF	DESIGN CHANGE	26-Jul-13
PCN13021	51770-043LF	DESIGN CHANGE	26-Jul-13
PCN13021	51770-044LF	DESIGN CHANGE	26-Jul-13
PCN13021	51770-045LF	DESIGN CHANGE	26-Jul-13
PCN13021	51770-046LF	DESIGN CHANGE	26-Jul-13
PCN13021	51771-001	DESIGN CHANGE	26-Jul-13
PCN13021	51771-001LF	DESIGN CHANGE	26-Jul-13
PCN13021	51771-002	DESIGN CHANGE	26-Jul-13
PCN13021	51771-003	DESIGN CHANGE	26-Jul-13
PCN13021	51771-003LF	DESIGN CHANGE	26-Jul-13
PCN13021	51771-004	DESIGN CHANGE	26-Jul-13
PCN13021	51771-004LF	DESIGN CHANGE	26-Jul-13

PCN13021	51771-005	DESIGN CHANGE	26-Jul-13
PCN13021	51771-005LF	DESIGN CHANGE	26-Jul-13
PCN13021	51771-007	DESIGN CHANGE	26-Jul-13
PCN13021	51771-007LF	DESIGN CHANGE	26-Jul-13
PCN13021	51771-008	DESIGN CHANGE	26-Jul-13
PCN13021	51771-008LF	DESIGN CHANGE	26-Jul-13
PCN13021	51771-009	DESIGN CHANGE	26-Jul-13
PCN13021	51771-009LF	DESIGN CHANGE	26-Jul-13
PCN13021	51771-011	DESIGN CHANGE	26-Jul-13
PCN13021	51771-011LF	DESIGN CHANGE	26-Jul-13
PCN13021	51771-012	DESIGN CHANGE	26-Jul-13
PCN13021	51771-012LF	DESIGN CHANGE	26-Jul-13
PCN13021	51771-013LF	DESIGN CHANGE	26-Jul-13
PCN13021	51771-015LF	DESIGN CHANGE	26-Jul-13
PCN13021	51771-018LF	DESIGN CHANGE	26-Jul-13
PCN13021	51771-019LF	DESIGN CHANGE	26-Jul-13
PCN13021	51771-020LF	DESIGN CHANGE	26-Jul-13
PCN13021	51771-023LF	DESIGN CHANGE	26-Jul-13
PCN13021	51771-024LF	DESIGN CHANGE	26-Jul-13
PCN13021	51771-025LF	DESIGN CHANGE	26-Jul-13
PCN13021	51771-026LF	DESIGN CHANGE	26-Jul-13
PCN13021	51772-001	DESIGN CHANGE	26-Jul-13
PCN13021	51772-001LF	DESIGN CHANGE	26-Jul-13
PCN13021	51772-003	DESIGN CHANGE	26-Jul-13
PCN13021	51772-003LF	DESIGN CHANGE	26-Jul-13
PCN13021	51772-005LF	DESIGN CHANGE	26-Jul-13
PCN13021	51772-006	DESIGN CHANGE	26-Jul-13
PCN13021	51772-006LF	DESIGN CHANGE	26-Jul-13
PCN13021	51772-007	DESIGN CHANGE	26-Jul-13
PCN13021	51772-007LF	DESIGN CHANGE	26-Jul-13
PCN13021	51772-008LF	DESIGN CHANGE	26-Jul-13
PCN13021	51772-009	DESIGN CHANGE	26-Jul-13
PCN13021	51772-009LF	DESIGN CHANGE	26-Jul-13
PCN13021	51772-012LF	DESIGN CHANGE	26-Jul-13
PCN13021	51772-013LF	DESIGN CHANGE	26-Jul-13
PCN13021	51772-017LF	DESIGN CHANGE	26-Jul-13
PCN13021	51772-018LF	DESIGN CHANGE	26-Jul-13
PCN13021	51772-019LF	DESIGN CHANGE	26-Jul-13
PCN13021	51772-021LF	DESIGN CHANGE	26-Jul-13
PCN13021	51772-022LF	DESIGN CHANGE	26-Jul-13
PCN13021	51772-024LF	DESIGN CHANGE	26-Jul-13

PCN13021	51772-025LF	DESIGN CHANGE	26-Jul-13
PCN13021	51772-030LF	DESIGN CHANGE	26-Jul-13
PCN13021	51772-031LF	DESIGN CHANGE	26-Jul-13
PCN13021	51772-032LF	DESIGN CHANGE	26-Jul-13
PCN13021	51776-001	DESIGN CHANGE	26-Jul-13
PCN13021	51776-001LF	DESIGN CHANGE	26-Jul-13
PCN13021	51776-003	DESIGN CHANGE	26-Jul-13
PCN13021	51776-003LF	DESIGN CHANGE	26-Jul-13
PCN13021	51776-004LF	DESIGN CHANGE	26-Jul-13
PCN13021	51783-001	DESIGN CHANGE	26-Jul-13
PCN13021	51783-001LF	DESIGN CHANGE	26-Jul-13
PCN13021	51783-002	DESIGN CHANGE	26-Jul-13
PCN13021	51783-002LF	DESIGN CHANGE	26-Jul-13
PCN13021	51784-001	DESIGN CHANGE	26-Jul-13
PCN13021	51784-002	DESIGN CHANGE	26-Jul-13
PCN13021	51784-002LF	DESIGN CHANGE	26-Jul-13
PCN13021	51785-001	DESIGN CHANGE	26-Jul-13
PCN13021	51785-001LF	DESIGN CHANGE	26-Jul-13
PCN13021	51785-002	DESIGN CHANGE	26-Jul-13
PCN13021	51785-002LF	DESIGN CHANGE	26-Jul-13
PCN13021	51786-001	DESIGN CHANGE	26-Jul-13
PCN13021	51786-001LF	DESIGN CHANGE	26-Jul-13
PCN13021	51786-002	DESIGN CHANGE	26-Jul-13
PCN13021	51786-003	DESIGN CHANGE	26-Jul-13
PCN13021	51786-003LF	DESIGN CHANGE	26-Jul-13
PCN13021	51787-001	DESIGN CHANGE	26-Jul-13
PCN13021	51787-001LF	DESIGN CHANGE	26-Jul-13
PCN13021	51787-002	DESIGN CHANGE	26-Jul-13
PCN13021	51787-003	DESIGN CHANGE	26-Jul-13
PCN13021	51787-003LF	DESIGN CHANGE	26-Jul-13
PCN13021	51787-004	DESIGN CHANGE	26-Jul-13
PCN13021	51787-004LF	DESIGN CHANGE	26-Jul-13
PCN13021	51792-001	DESIGN CHANGE	26-Jul-13
PCN13021	51792-001LF	DESIGN CHANGE	26-Jul-13
PCN13021	51792-002	DESIGN CHANGE	26-Jul-13
PCN13021	51793-001	DESIGN CHANGE	26-Jul-13
PCN13021	51793-001LF	DESIGN CHANGE	26-Jul-13
PCN13021	51793-002	DESIGN CHANGE	26-Jul-13
PCN13021	51793-002LF	DESIGN CHANGE	26-Jul-13
PCN13021	51793-003	DESIGN CHANGE	26-Jul-13
PCN13021	51793-003LF	DESIGN CHANGE	26-Jul-13

PCN13021	51793-004LF	DESIGN CHANGE	26-Jul-13
PCN13021	51796-001	DESIGN CHANGE	26-Jul-13
PCN13021	51796-001LF	DESIGN CHANGE	26-Jul-13
PCN13021	51797-001	DESIGN CHANGE	26-Jul-13
PCN13021	51797-001LF	DESIGN CHANGE	26-Jul-13
PCN13021	51810-001	DESIGN CHANGE	26-Jul-13
PCN13021	51810-001LF	DESIGN CHANGE	26-Jul-13
PCN13021	51810-002	DESIGN CHANGE	26-Jul-13
PCN13021	51810-004	DESIGN CHANGE	26-Jul-13
PCN13021	51810-004LF	DESIGN CHANGE	26-Jul-13
PCN13021	51823-001	DESIGN CHANGE	26-Jul-13
PCN13021	51824-001	DESIGN CHANGE	26-Jul-13
PCN13021	51824-002	DESIGN CHANGE	26-Jul-13
PCN13021	51824-002LF	DESIGN CHANGE	26-Jul-13
PCN13021	51824-003LF	DESIGN CHANGE	26-Jul-13
PCN13021	51824-004LF	DESIGN CHANGE	26-Jul-13
PCN13021	51824-005LF	DESIGN CHANGE	26-Jul-13
PCN13021	51825-001	DESIGN CHANGE	26-Jul-13
PCN13021	51830-001	DESIGN CHANGE	26-Jul-13
PCN13021	51830-001LF	DESIGN CHANGE	26-Jul-13
PCN13021	51836-001	DESIGN CHANGE	26-Jul-13
PCN13021	51850-001	DESIGN CHANGE	26-Jul-13
PCN13021	51856-001	DESIGN CHANGE	26-Jul-13
PCN13021	51856-001LF	DESIGN CHANGE	26-Jul-13
PCN13021	51857-001	DESIGN CHANGE	26-Jul-13
PCN13021	51857-001LF	DESIGN CHANGE	26-Jul-13
PCN13021	51857-002	DESIGN CHANGE	26-Jul-13
PCN13021	51857-002LF	DESIGN CHANGE	26-Jul-13
PCN13021	51860-001	DESIGN CHANGE	26-Jul-13
PCN13021	51860-001LF	DESIGN CHANGE	26-Jul-13
PCN13021	51860-002	DESIGN CHANGE	26-Jul-13
PCN13021	51860-002LF	DESIGN CHANGE	26-Jul-13
PCN13021	51862-001	DESIGN CHANGE	26-Jul-13
PCN13021	51862-001LF	DESIGN CHANGE	26-Jul-13
PCN13021	51862-002	DESIGN CHANGE	26-Jul-13
PCN13021	51862-002LF	DESIGN CHANGE	26-Jul-13
PCN13021	51863-001	DESIGN CHANGE	26-Jul-13
PCN13021	51863-001LF	DESIGN CHANGE	26-Jul-13
PCN13021	51863-002	DESIGN CHANGE	26-Jul-13
PCN13021	51866-002	DESIGN CHANGE	26-Jul-13
PCN13021	51866-003	DESIGN CHANGE	26-Jul-13



PCN13021	51866-005	DESIGN CHANGE	26-Jul-13
PCN13021	51866-006	DESIGN CHANGE	26-Jul-13
PCN13021	51866-007	DESIGN CHANGE	26-Jul-13
PCN13021	51866-007LF	DESIGN CHANGE	26-Jul-13
PCN13021	51866-008	DESIGN CHANGE	26-Jul-13
PCN13021	51866-008LF	DESIGN CHANGE	26-Jul-13
PCN13021	51866-013	DESIGN CHANGE	26-Jul-13
PCN13021	51866-013LF	DESIGN CHANGE	26-Jul-13
PCN13021	51866-014	DESIGN CHANGE	26-Jul-13
PCN13021	51866-014LF	DESIGN CHANGE	26-Jul-13
PCN13021	51866-015	DESIGN CHANGE	26-Jul-13
PCN13021	51866-015LF	DESIGN CHANGE	26-Jul-13
PCN13021	51866-017	DESIGN CHANGE	26-Jul-13
PCN13021	51866-017LF	DESIGN CHANGE	26-Jul-13
PCN13021	51866-018	DESIGN CHANGE	26-Jul-13
PCN13021	51866-019	DESIGN CHANGE	26-Jul-13
PCN13021	51866-021	DESIGN CHANGE	26-Jul-13
PCN13021	51866-021LF	DESIGN CHANGE	26-Jul-13
PCN13021	51866-023	DESIGN CHANGE	26-Jul-13
PCN13021	51866-023LF	DESIGN CHANGE	26-Jul-13
PCN13021	51866-024	DESIGN CHANGE	26-Jul-13
PCN13021	51866-025	DESIGN CHANGE	26-Jul-13
PCN13021	51866-025LF	DESIGN CHANGE	26-Jul-13
PCN13021	51866-026	DESIGN CHANGE	26-Jul-13
PCN13021	51866-027	DESIGN CHANGE	26-Jul-13
PCN13021	51866-028	DESIGN CHANGE	26-Jul-13
PCN13021	51866-028LF	DESIGN CHANGE	26-Jul-13
PCN13021	51866-029	DESIGN CHANGE	26-Jul-13
PCN13021	51866-030	DESIGN CHANGE	26-Jul-13
PCN13021	51866-032LF	DESIGN CHANGE	26-Jul-13
PCN13021	51866-035	DESIGN CHANGE	26-Jul-13
PCN13021	51866-035LF	DESIGN CHANGE	26-Jul-13
PCN13021	51866-036	DESIGN CHANGE	26-Jul-13
PCN13021	51866-037	DESIGN CHANGE	26-Jul-13
PCN13021	51866-037LF	DESIGN CHANGE	26-Jul-13
PCN13021	51866-039LF	DESIGN CHANGE	26-Jul-13
PCN13021	51866-041LF	DESIGN CHANGE	26-Jul-13
PCN13021	51866-042LF	DESIGN CHANGE	26-Jul-13
PCN13021	51866-044LF	DESIGN CHANGE	26-Jul-13
PCN13021	51866-046LF	DESIGN CHANGE	26-Jul-13
PCN13021	51866-047LF	DESIGN CHANGE	26-Jul-13

PCN13021	51866-048LF	DESIGN CHANGE	26-Jul-13
PCN13021	51866-050LF	DESIGN CHANGE	26-Jul-13
PCN13021	51866-051LF	DESIGN CHANGE	26-Jul-13
PCN13021	51866-053LF	DESIGN CHANGE	26-Jul-13
PCN13021	51868-001	DESIGN CHANGE	26-Jul-13
PCN13021	51868-002	DESIGN CHANGE	26-Jul-13
PCN13021	51868-003	DESIGN CHANGE	26-Jul-13
PCN13021	51874-001	DESIGN CHANGE	26-Jul-13
PCN13021	51874-001LF	DESIGN CHANGE	26-Jul-13
PCN13021	51875-001	DESIGN CHANGE	26-Jul-13
PCN13021	51875-001LF	DESIGN CHANGE	26-Jul-13
PCN13021	51875-002	DESIGN CHANGE	26-Jul-13
PCN13021	51875-002LF	DESIGN CHANGE	26-Jul-13
PCN13021	51878-001	DESIGN CHANGE	26-Jul-13
PCN13021	51882-001	DESIGN CHANGE	26-Jul-13
PCN13021	51882-001LF	DESIGN CHANGE	26-Jul-13
PCN13021	51886-001	DESIGN CHANGE	26-Jul-13
PCN13021	51887-001	DESIGN CHANGE	26-Jul-13
PCN13021	51890-002	DESIGN CHANGE	26-Jul-13
PCN13021	51890-002LF	DESIGN CHANGE	26-Jul-13
PCN13021	51894-001	DESIGN CHANGE	26-Jul-13
PCN13021	51894-001LF	DESIGN CHANGE	26-Jul-13
PCN13021	51894-002	DESIGN CHANGE	26-Jul-13
PCN13021	51894-003	DESIGN CHANGE	26-Jul-13
PCN13021	51894-003LF	DESIGN CHANGE	26-Jul-13
PCN13021	51894-004	DESIGN CHANGE	26-Jul-13
PCN13021	51894-004LF	DESIGN CHANGE	26-Jul-13
PCN13021	51897-001	DESIGN CHANGE	26-Jul-13
PCN13021	51897-002	DESIGN CHANGE	26-Jul-13
PCN13021	51897-003	DESIGN CHANGE	26-Jul-13
PCN13021	51897-003LF	DESIGN CHANGE	26-Jul-13
PCN13021	51897-004	DESIGN CHANGE	26-Jul-13
PCN13021	51897-005	DESIGN CHANGE	26-Jul-13
PCN13021	51897-005LF	DESIGN CHANGE	26-Jul-13
PCN13021	51897-007	DESIGN CHANGE	26-Jul-13
PCN13021	51897-013	DESIGN CHANGE	26-Jul-13
PCN13021	51897-014	DESIGN CHANGE	26-Jul-13
PCN13021	51897-014LF	DESIGN CHANGE	26-Jul-13
PCN13021	51897-015	DESIGN CHANGE	26-Jul-13
PCN13021	51897-016LF	DESIGN CHANGE	26-Jul-13
PCN13021	51897-017LF	DESIGN CHANGE	26-Jul-13

PCN13021	51903-001	DESIGN CHANGE	26-Jul-13
PCN13021	51904-001	DESIGN CHANGE	26-Jul-13
PCN13021	51905-001	DESIGN CHANGE	26-Jul-13
PCN13021	51906-001	DESIGN CHANGE	26-Jul-13
PCN13021	51907-001	DESIGN CHANGE	26-Jul-13
PCN13021	51907-001LF	DESIGN CHANGE	26-Jul-13
PCN13021	51907-002	DESIGN CHANGE	26-Jul-13
PCN13021	51907-002LF	DESIGN CHANGE	26-Jul-13
PCN13021	51907-003	DESIGN CHANGE	26-Jul-13
PCN13021	51907-003LF	DESIGN CHANGE	26-Jul-13
PCN13021	51907-004	DESIGN CHANGE	26-Jul-13
PCN13021	51907-004LF	DESIGN CHANGE	26-Jul-13
PCN13021	51907-005LF	DESIGN CHANGE	26-Jul-13
PCN13021	51909-001	DESIGN CHANGE	26-Jul-13
PCN13021	51909-001LF	DESIGN CHANGE	26-Jul-13
PCN13021	51914-001	DESIGN CHANGE	26-Jul-13
PCN13021	51915-001	DESIGN CHANGE	26-Jul-13
PCN13021	51915-002	DESIGN CHANGE	26-Jul-13
PCN13021	51915-003	DESIGN CHANGE	26-Jul-13
PCN13021	51915-003LF	DESIGN CHANGE	26-Jul-13
PCN13021	51915-004	DESIGN CHANGE	26-Jul-13
PCN13021	51915-004LF	DESIGN CHANGE	26-Jul-13
PCN13021	51915-005	DESIGN CHANGE	26-Jul-13
PCN13021	51915-006	DESIGN CHANGE	26-Jul-13
PCN13021	51915-007	DESIGN CHANGE	26-Jul-13
PCN13021	51915-009	DESIGN CHANGE	26-Jul-13
PCN13021	51915-010	DESIGN CHANGE	26-Jul-13
PCN13021	51915-010LF	DESIGN CHANGE	26-Jul-13
PCN13021	51915-011	DESIGN CHANGE	26-Jul-13
PCN13021	51915-011LF	DESIGN CHANGE	26-Jul-13
PCN13021	51915-012	DESIGN CHANGE	26-Jul-13
PCN13021	51915-012LF	DESIGN CHANGE	26-Jul-13
PCN13021	51915-013	DESIGN CHANGE	26-Jul-13
PCN13021	51915-013LF	DESIGN CHANGE	26-Jul-13
PCN13021	51915-014	DESIGN CHANGE	26-Jul-13
PCN13021	51915-014LF	DESIGN CHANGE	26-Jul-13
PCN13021	51915-015	DESIGN CHANGE	26-Jul-13
PCN13021	51915-016	DESIGN CHANGE	26-Jul-13
PCN13021	51915-016LF	DESIGN CHANGE	26-Jul-13
PCN13021	51915-017	DESIGN CHANGE	26-Jul-13
PCN13021	51915-017LF	DESIGN CHANGE	26-Jul-13

PCN13021	51915-018	DESIGN CHANGE	26-Jul-13
PCN13021	51915-023	DESIGN CHANGE	26-Jul-13
PCN13021	51915-023LF	DESIGN CHANGE	26-Jul-13
PCN13021	51915-024	DESIGN CHANGE	26-Jul-13
PCN13021	51915-025	DESIGN CHANGE	26-Jul-13
PCN13021	51915-025LF	DESIGN CHANGE	26-Jul-13
PCN13021	51915-026	DESIGN CHANGE	26-Jul-13
PCN13021	51915-027	DESIGN CHANGE	26-Jul-13
PCN13021	51915-028	DESIGN CHANGE	26-Jul-13
PCN13021	51915-028LF	DESIGN CHANGE	26-Jul-13
PCN13021	51915-029	DESIGN CHANGE	26-Jul-13
PCN13021	51915-029LF	DESIGN CHANGE	26-Jul-13
PCN13021	51915-030	DESIGN CHANGE	26-Jul-13
PCN13021	51915-031	DESIGN CHANGE	26-Jul-13
PCN13021	51915-032	DESIGN CHANGE	26-Jul-13
PCN13021	51915-033	DESIGN CHANGE	26-Jul-13
PCN13021	51915-034	DESIGN CHANGE	26-Jul-13
PCN13021	51915-036	DESIGN CHANGE	26-Jul-13
PCN13021	51915-036LF	DESIGN CHANGE	26-Jul-13
PCN13021	51915-037	DESIGN CHANGE	26-Jul-13
PCN13021	51915-037LF	DESIGN CHANGE	26-Jul-13
PCN13021	51915-038	DESIGN CHANGE	26-Jul-13
PCN13021	51915-039	DESIGN CHANGE	26-Jul-13
PCN13021	51915-040	DESIGN CHANGE	26-Jul-13
PCN13021	51915-040LF	DESIGN CHANGE	26-Jul-13
PCN13021	51915-041	DESIGN CHANGE	26-Jul-13
PCN13021	51915-041LF	DESIGN CHANGE	26-Jul-13
PCN13021	51915-042	DESIGN CHANGE	26-Jul-13
PCN13021	51915-043	DESIGN CHANGE	26-Jul-13
PCN13021	51915-044	DESIGN CHANGE	26-Jul-13
PCN13021	51915-044LF	DESIGN CHANGE	26-Jul-13
PCN13021	51915-045	DESIGN CHANGE	26-Jul-13
PCN13021	51915-046	DESIGN CHANGE	26-Jul-13
PCN13021	51915-047	DESIGN CHANGE	26-Jul-13
PCN13021	51915-047LF	DESIGN CHANGE	26-Jul-13
PCN13021	51915-048	DESIGN CHANGE	26-Jul-13
PCN13021	51915-049	DESIGN CHANGE	26-Jul-13
PCN13021	51915-049LF	DESIGN CHANGE	26-Jul-13
PCN13021	51915-050	DESIGN CHANGE	26-Jul-13
PCN13021	51915-050LF	DESIGN CHANGE	26-Jul-13
PCN13021	51915-051	DESIGN CHANGE	26-Jul-13

PCN13021	51915-051LF	DESIGN CHANGE	26-Jul-13
PCN13021	51915-052	DESIGN CHANGE	26-Jul-13
PCN13021	51915-053	DESIGN CHANGE	26-Jul-13
PCN13021	51915-054	DESIGN CHANGE	26-Jul-13
PCN13021	51915-054LF	DESIGN CHANGE	26-Jul-13
PCN13021	51915-055	DESIGN CHANGE	26-Jul-13
PCN13021	51915-057	DESIGN CHANGE	26-Jul-13
PCN13021	51915-057LF	DESIGN CHANGE	26-Jul-13
PCN13021	51915-058	DESIGN CHANGE	26-Jul-13
PCN13021	51915-058LF	DESIGN CHANGE	26-Jul-13
PCN13021	51915-059	DESIGN CHANGE	26-Jul-13
PCN13021	51915-059LF	DESIGN CHANGE	26-Jul-13
PCN13021	51915-060	DESIGN CHANGE	26-Jul-13
PCN13021	51915-061	DESIGN CHANGE	26-Jul-13
PCN13021	51915-062	DESIGN CHANGE	26-Jul-13
PCN13021	51915-062LF	DESIGN CHANGE	26-Jul-13
PCN13021	51915-063	DESIGN CHANGE	26-Jul-13
PCN13021	51915-064	DESIGN CHANGE	26-Jul-13
PCN13021	51915-064LF	DESIGN CHANGE	26-Jul-13
PCN13021	51915-065LF	DESIGN CHANGE	26-Jul-13
PCN13021	51915-066	DESIGN CHANGE	26-Jul-13
PCN13021	51915-067	DESIGN CHANGE	26-Jul-13
PCN13021	51915-067LF	DESIGN CHANGE	26-Jul-13
PCN13021	51915-068	DESIGN CHANGE	26-Jul-13
PCN13021	51915-068LF	DESIGN CHANGE	26-Jul-13
PCN13021	51915-070	DESIGN CHANGE	26-Jul-13
PCN13021	51915-070LF	DESIGN CHANGE	26-Jul-13
PCN13021	51915-071	DESIGN CHANGE	26-Jul-13
PCN13021	51915-071LF	DESIGN CHANGE	26-Jul-13
PCN13021	51915-072	DESIGN CHANGE	26-Jul-13
PCN13021	51915-072LF	DESIGN CHANGE	26-Jul-13
PCN13021	51915-073	DESIGN CHANGE	26-Jul-13
PCN13021	51915-073LF	DESIGN CHANGE	26-Jul-13
PCN13021	51915-074	DESIGN CHANGE	26-Jul-13
PCN13021	51915-074LF	DESIGN CHANGE	26-Jul-13
PCN13021	51915-075LF	DESIGN CHANGE	26-Jul-13
PCN13021	51915-077	DESIGN CHANGE	26-Jul-13
PCN13021	51915-077LF	DESIGN CHANGE	26-Jul-13
PCN13021	51915-078	DESIGN CHANGE	26-Jul-13
PCN13021	51915-078LF	DESIGN CHANGE	26-Jul-13
PCN13021	51915-079	DESIGN CHANGE	26-Jul-13

PCN13021	51915-079LF	DESIGN CHANGE	26-Jul-13
PCN13021	51915-080	DESIGN CHANGE	26-Jul-13
PCN13021	51915-080LF	DESIGN CHANGE	26-Jul-13
PCN13021	51915-082	DESIGN CHANGE	26-Jul-13
PCN13021	51915-082LF	DESIGN CHANGE	26-Jul-13
PCN13021	51915-084LF	DESIGN CHANGE	26-Jul-13
PCN13021	51915-090	DESIGN CHANGE	26-Jul-13
PCN13021	51915-091	DESIGN CHANGE	26-Jul-13
PCN13021	51915-092LF	DESIGN CHANGE	26-Jul-13
PCN13021	51915-093LF	DESIGN CHANGE	26-Jul-13
PCN13021	51915-094LF	DESIGN CHANGE	26-Jul-13
PCN13021	51915-096LF	DESIGN CHANGE	26-Jul-13
PCN13021	51915-098	DESIGN CHANGE	26-Jul-13
PCN13021	51915-098LF	DESIGN CHANGE	26-Jul-13
PCN13021	51915-099LF	DESIGN CHANGE	26-Jul-13
PCN13021	51915-100LF	DESIGN CHANGE	26-Jul-13
PCN13021	51915-101LF	DESIGN CHANGE	26-Jul-13
PCN13021	51915-102LF	DESIGN CHANGE	26-Jul-13
PCN13021	51915-103LF	DESIGN CHANGE	26-Jul-13
PCN13021	51915-105LF	DESIGN CHANGE	26-Jul-13
PCN13021	51915-107LF	DESIGN CHANGE	26-Jul-13
PCN13021	51915-108LF	DESIGN CHANGE	26-Jul-13
PCN13021	51915-109LF	DESIGN CHANGE	26-Jul-13
PCN13021	51915-110	DESIGN CHANGE	26-Jul-13
PCN13021	51915-110LF	DESIGN CHANGE	26-Jul-13
PCN13021	51915-111	DESIGN CHANGE	26-Jul-13
PCN13021	51915-113LF	DESIGN CHANGE	26-Jul-13
PCN13021	51915-115LF	DESIGN CHANGE	26-Jul-13
PCN13021	51915-117	DESIGN CHANGE	26-Jul-13
PCN13021	51915-117LF	DESIGN CHANGE	26-Jul-13
PCN13021	51915-118	DESIGN CHANGE	26-Jul-13
PCN13021	51915-118LF	DESIGN CHANGE	26-Jul-13
PCN13021	51915-119	DESIGN CHANGE	26-Jul-13
PCN13021	51915-119LF	DESIGN CHANGE	26-Jul-13
PCN13021	51915-120	DESIGN CHANGE	26-Jul-13
PCN13021	51915-120LF	DESIGN CHANGE	26-Jul-13
PCN13021	51915-121	DESIGN CHANGE	26-Jul-13
PCN13021	51915-121LF	DESIGN CHANGE	26-Jul-13
PCN13021	51915-122	DESIGN CHANGE	26-Jul-13
PCN13021	51915-122LF	DESIGN CHANGE	26-Jul-13
PCN13021	51915-124LF	DESIGN CHANGE	26-Jul-13

PCN13021	51915-126	DESIGN CHANGE	26-Jul-13
PCN13021	51915-126LF	DESIGN CHANGE	26-Jul-13
PCN13021	51915-128LF	DESIGN CHANGE	26-Jul-13
PCN13021	51915-129LF	DESIGN CHANGE	26-Jul-13
PCN13021	51915-130LF	DESIGN CHANGE	26-Jul-13
PCN13021	51915-131LF	DESIGN CHANGE	26-Jul-13
PCN13021	51915-132LF	DESIGN CHANGE	26-Jul-13
PCN13021	51915-133LF	DESIGN CHANGE	26-Jul-13
PCN13021	51915-134LF	DESIGN CHANGE	26-Jul-13
PCN13021	51915-135LF	DESIGN CHANGE	26-Jul-13
PCN13021	51915-136LF	DESIGN CHANGE	26-Jul-13
PCN13021	51915-139LF	DESIGN CHANGE	26-Jul-13
PCN13021	51915-140LF	DESIGN CHANGE	26-Jul-13
PCN13021	51915-141LF	DESIGN CHANGE	26-Jul-13
PCN13021	51915-143LF	DESIGN CHANGE	26-Jul-13
PCN13021	51915-144	DESIGN CHANGE	26-Jul-13
PCN13021	51915-144LF	DESIGN CHANGE	26-Jul-13
PCN13021	51915-145LF	DESIGN CHANGE	26-Jul-13
PCN13021	51915-148LF	DESIGN CHANGE	26-Jul-13
PCN13021	51915-152LF	DESIGN CHANGE	26-Jul-13
PCN13021	51915-153LF	DESIGN CHANGE	26-Jul-13
PCN13021	51915-157LF	DESIGN CHANGE	26-Jul-13
PCN13021	51915-158LF	DESIGN CHANGE	26-Jul-13
PCN13021	51915-159LF	DESIGN CHANGE	26-Jul-13
PCN13021	51915-160LF	DESIGN CHANGE	26-Jul-13
PCN13021	51915-162LF	DESIGN CHANGE	26-Jul-13
PCN13021	51915-163	DESIGN CHANGE	26-Jul-13
PCN13021	51915-163LF	DESIGN CHANGE	26-Jul-13
PCN13021	51915-164LF	DESIGN CHANGE	26-Jul-13
PCN13021	51915-165LF	DESIGN CHANGE	26-Jul-13
PCN13021	51915-166LF	DESIGN CHANGE	26-Jul-13
PCN13021	51915-171LF	DESIGN CHANGE	26-Jul-13
PCN13021	51915-172LF	DESIGN CHANGE	26-Jul-13
PCN13021	51915-176LF	DESIGN CHANGE	26-Jul-13
PCN13021	51915-177LF	DESIGN CHANGE	26-Jul-13
PCN13021	51915-178LF	DESIGN CHANGE	26-Jul-13
PCN13021	51915-183LF	DESIGN CHANGE	26-Jul-13
PCN13021	51915-184LF	DESIGN CHANGE	26-Jul-13
PCN13021	51915-185LF	DESIGN CHANGE	26-Jul-13
PCN13021	51915-189LF	DESIGN CHANGE	26-Jul-13
PCN13021	51915-191LF	DESIGN CHANGE	26-Jul-13

PCN13021	51915-192LF	DESIGN CHANGE	26-Jul-13
PCN13021	51915-195LF	DESIGN CHANGE	26-Jul-13
PCN13021	51915-197LF	DESIGN CHANGE	26-Jul-13
PCN13021	51915-198LF	DESIGN CHANGE	26-Jul-13
PCN13021	51915-199LF	DESIGN CHANGE	26-Jul-13
PCN13021	51915-200LF	DESIGN CHANGE	26-Jul-13
PCN13021	51915-204LF	DESIGN CHANGE	26-Jul-13
PCN13021	51915-210LF	DESIGN CHANGE	26-Jul-13
PCN13021	51915-211LF	DESIGN CHANGE	26-Jul-13
PCN13021	51915-215LF	DESIGN CHANGE	26-Jul-13
PCN13021	51915-216LF	DESIGN CHANGE	26-Jul-13
PCN13021	51915-217LF	DESIGN CHANGE	26-Jul-13
PCN13021	51915-221LF	DESIGN CHANGE	26-Jul-13
PCN13021	51915-223LF	DESIGN CHANGE	26-Jul-13
PCN13021	51915-224LF	DESIGN CHANGE	26-Jul-13
PCN13021	51915-225LF	DESIGN CHANGE	26-Jul-13
PCN13021	51915-226LF	DESIGN CHANGE	26-Jul-13
PCN13021	51915-227LF	DESIGN CHANGE	26-Jul-13
PCN13021	51915-228LF	DESIGN CHANGE	26-Jul-13
PCN13021	51915-232LF	DESIGN CHANGE	26-Jul-13
PCN13021	51915-234LF	DESIGN CHANGE	26-Jul-13
PCN13021	51915-235LF	DESIGN CHANGE	26-Jul-13
PCN13021	51915-237LF	DESIGN CHANGE	26-Jul-13
PCN13021	51915-238LF	DESIGN CHANGE	26-Jul-13
PCN13021	51915-241LF	DESIGN CHANGE	26-Jul-13
PCN13021	51915-242LF	DESIGN CHANGE	26-Jul-13
PCN13021	51915-243LF	DESIGN CHANGE	26-Jul-13
PCN13021	51915-245LF	DESIGN CHANGE	26-Jul-13
PCN13021	51915-246LF	DESIGN CHANGE	26-Jul-13
PCN13021	51915-247LF	DESIGN CHANGE	26-Jul-13
PCN13021	51915-249LF	DESIGN CHANGE	26-Jul-13
PCN13021	51915-250LF	DESIGN CHANGE	26-Jul-13
PCN13021	51915-251LF	DESIGN CHANGE	26-Jul-13
PCN13021	51915-253LF	DESIGN CHANGE	26-Jul-13
PCN13021	51915-259LF	DESIGN CHANGE	26-Jul-13
PCN13021	51915-260LF	DESIGN CHANGE	26-Jul-13
PCN13021	51915-262LF	DESIGN CHANGE	26-Jul-13
PCN13021	51915-263LF	DESIGN CHANGE	26-Jul-13
PCN13021	51915-265LF	DESIGN CHANGE	26-Jul-13
PCN13021	51915-266LF	DESIGN CHANGE	26-Jul-13
PCN13021	51915-268LF	DESIGN CHANGE	26-Jul-13



PCN13021	51915-270LF	DESIGN CHANGE	26-Jul-13
PCN13021	51915-272LF	DESIGN CHANGE	26-Jul-13
PCN13021	51915-273LF	DESIGN CHANGE	26-Jul-13
PCN13021	51915-274LF	DESIGN CHANGE	26-Jul-13
PCN13021	51915-275LF	DESIGN CHANGE	26-Jul-13
PCN13021	51915-282LF	DESIGN CHANGE	26-Jul-13
PCN13021	51915-283LF	DESIGN CHANGE	26-Jul-13
PCN13021	51915-289LF	DESIGN CHANGE	26-Jul-13
PCN13021	51915-290LF	DESIGN CHANGE	26-Jul-13
PCN13021	51915-292LF	DESIGN CHANGE	26-Jul-13
PCN13021	51915-294LF	DESIGN CHANGE	26-Jul-13
PCN13021	51915-295LF	DESIGN CHANGE	26-Jul-13
PCN13021	51915-297LF	DESIGN CHANGE	26-Jul-13
PCN13021	51915-298LF	DESIGN CHANGE	26-Jul-13
PCN13021	51915-299LF	DESIGN CHANGE	26-Jul-13
PCN13021	51915-300LF	DESIGN CHANGE	26-Jul-13
PCN13021	51915-302LF	DESIGN CHANGE	26-Jul-13
PCN13021	51915-303LF	DESIGN CHANGE	26-Jul-13
PCN13021	51915-309LF	DESIGN CHANGE	26-Jul-13
PCN13021	51915-313LF	DESIGN CHANGE	26-Jul-13
PCN13021	51915-314LF	DESIGN CHANGE	26-Jul-13
PCN13021	51915-317LF	DESIGN CHANGE	26-Jul-13
PCN13021	51915-318LF	DESIGN CHANGE	26-Jul-13
PCN13021	51915-319LF	DESIGN CHANGE	26-Jul-13
PCN13021	51915-323LF	DESIGN CHANGE	26-Jul-13
PCN13021	51915-326LF	DESIGN CHANGE	26-Jul-13
PCN13021	51915-330LF	DESIGN CHANGE	26-Jul-13
PCN13021	51915-333LF	DESIGN CHANGE	26-Jul-13
PCN13021	51915-335LF	DESIGN CHANGE	26-Jul-13
PCN13021	51915-338LF	DESIGN CHANGE	26-Jul-13
PCN13021	51915-341LF	DESIGN CHANGE	26-Jul-13
PCN13021	51915-342LF	DESIGN CHANGE	26-Jul-13
PCN13021	51915-343LF	DESIGN CHANGE	26-Jul-13
PCN13021	51915-348LF	DESIGN CHANGE	26-Jul-13
PCN13021	51915-349LF	DESIGN CHANGE	26-Jul-13
PCN13021	51915-351LF	DESIGN CHANGE	26-Jul-13
PCN13021	51915-353LF	DESIGN CHANGE	26-Jul-13
PCN13021	51915-354LF	DESIGN CHANGE	26-Jul-13
PCN13021	51915-355LF	DESIGN CHANGE	26-Jul-13
PCN13021	51915-356LF	DESIGN CHANGE	26-Jul-13
PCN13021	51915-358LF	DESIGN CHANGE	26-Jul-13

PCN13021	51915-359LF	DESIGN CHANGE	26-Jul-13
PCN13021	51915-360LF	DESIGN CHANGE	26-Jul-13
PCN13021	51915-365LF	DESIGN CHANGE	26-Jul-13
PCN13021	51915-366LF	DESIGN CHANGE	26-Jul-13
PCN13021	51915-367LF	DESIGN CHANGE	26-Jul-13
PCN13021	51915-369LF	DESIGN CHANGE	26-Jul-13
PCN13021	51915-370LF	DESIGN CHANGE	26-Jul-13
PCN13021	51915-371LF	DESIGN CHANGE	26-Jul-13
PCN13021	51915-372LF	DESIGN CHANGE	26-Jul-13
PCN13021	51915-373LF	DESIGN CHANGE	26-Jul-13
PCN13021	51915-375LF	DESIGN CHANGE	26-Jul-13
PCN13021	51915-376LF	DESIGN CHANGE	26-Jul-13
PCN13021	51915-377LF	DESIGN CHANGE	26-Jul-13
PCN13021	51915-378LF	DESIGN CHANGE	26-Jul-13
PCN13021	51915-379LF	DESIGN CHANGE	26-Jul-13
PCN13021	51915-380LF	DESIGN CHANGE	26-Jul-13
PCN13021	51915-381LF	DESIGN CHANGE	26-Jul-13
PCN13021	51915-382LF	DESIGN CHANGE	26-Jul-13
PCN13021	51915-383LF	DESIGN CHANGE	26-Jul-13
PCN13021	51915-384LF	DESIGN CHANGE	26-Jul-13
PCN13021	51915-386LF	DESIGN CHANGE	26-Jul-13
PCN13021	51915-388LF	DESIGN CHANGE	26-Jul-13
PCN13021	51918-001	DESIGN CHANGE	26-Jul-13
PCN13021	51921-001	DESIGN CHANGE	26-Jul-13
PCN13021	51921-002	DESIGN CHANGE	26-Jul-13
PCN13021	51921-002LF	DESIGN CHANGE	26-Jul-13
PCN13021	51921-003	DESIGN CHANGE	26-Jul-13
PCN13021	51921-006	DESIGN CHANGE	26-Jul-13
PCN13021	51921-006LF	DESIGN CHANGE	26-Jul-13
PCN13021	51921-008	DESIGN CHANGE	26-Jul-13
PCN13021	51921-008LF	DESIGN CHANGE	26-Jul-13
PCN13021	51921-011LF	DESIGN CHANGE	26-Jul-13
PCN13021	51921-013LF	DESIGN CHANGE	26-Jul-13
PCN13021	51921-014LF	DESIGN CHANGE	26-Jul-13
PCN13021	51921-015LF	DESIGN CHANGE	26-Jul-13
PCN13021	51921-016LF	DESIGN CHANGE	26-Jul-13
PCN13021	51921-017LF	DESIGN CHANGE	26-Jul-13
PCN13021	51923-001	DESIGN CHANGE	26-Jul-13
PCN13021	51923-001LF	DESIGN CHANGE	26-Jul-13
PCN13021	51923-002	DESIGN CHANGE	26-Jul-13
PCN13021	51923-003	DESIGN CHANGE	26-Jul-13

PCN13021	51923-003LF	DESIGN CHANGE	26-Jul-13
PCN13021	51923-005	DESIGN CHANGE	26-Jul-13
PCN13021	51923-005LF	DESIGN CHANGE	26-Jul-13
PCN13021	51923-006	DESIGN CHANGE	26-Jul-13
PCN13021	51923-006LF	DESIGN CHANGE	26-Jul-13
PCN13021	51923-007LF	DESIGN CHANGE	26-Jul-13
PCN13021	51923-008LF	DESIGN CHANGE	26-Jul-13
PCN13021	51923-009LF	DESIGN CHANGE	26-Jul-13
PCN13021	51927-001	DESIGN CHANGE	26-Jul-13
PCN13021	51927-002	DESIGN CHANGE	26-Jul-13
PCN13021	51927-002LF	DESIGN CHANGE	26-Jul-13
PCN13021	51927-003	DESIGN CHANGE	26-Jul-13
PCN13021	51927-004	DESIGN CHANGE	26-Jul-13
PCN13021	51927-005	DESIGN CHANGE	26-Jul-13
PCN13021	51927-006	DESIGN CHANGE	26-Jul-13
PCN13021	51927-007LF	DESIGN CHANGE	26-Jul-13
PCN13021	51927-008LF	DESIGN CHANGE	26-Jul-13
PCN13021	51927-009LF	DESIGN CHANGE	26-Jul-13
PCN13021	51929-001	DESIGN CHANGE	26-Jul-13
PCN13021	51929-001LF	DESIGN CHANGE	26-Jul-13
PCN13021	51929-002	DESIGN CHANGE	26-Jul-13
PCN13021	51929-002LF	DESIGN CHANGE	26-Jul-13
PCN13021	51929-003	DESIGN CHANGE	26-Jul-13
PCN13021	51929-003LF	DESIGN CHANGE	26-Jul-13
PCN13021	51929-005LF	DESIGN CHANGE	26-Jul-13
PCN13021	51931-001	DESIGN CHANGE	26-Jul-13
PCN13021	51932-001	DESIGN CHANGE	26-Jul-13
PCN13021	51935-001	DESIGN CHANGE	26-Jul-13
PCN13021	51935-002	DESIGN CHANGE	26-Jul-13
PCN13021	51935-002LF	DESIGN CHANGE	26-Jul-13
PCN13021	51935-003	DESIGN CHANGE	26-Jul-13
PCN13021	51935-003LF	DESIGN CHANGE	26-Jul-13
PCN13021	51936-001	DESIGN CHANGE	26-Jul-13
PCN13021	51936-002	DESIGN CHANGE	26-Jul-13
PCN13021	51936-002LF	DESIGN CHANGE	26-Jul-13
PCN13021	51936-003	DESIGN CHANGE	26-Jul-13
PCN13021	51936-003LF	DESIGN CHANGE	26-Jul-13
PCN13021	51939-001	DESIGN CHANGE	26-Jul-13
PCN13021	51939-002	DESIGN CHANGE	26-Jul-13
PCN13021	51939-002LF	DESIGN CHANGE	26-Jul-13
PCN13021	51939-003	DESIGN CHANGE	26-Jul-13

PCN13021	51939-003LF	DESIGN CHANGE	26-Jul-13
PCN13021	51939-004	DESIGN CHANGE	26-Jul-13
PCN13021	51939-004LF	DESIGN CHANGE	26-Jul-13
PCN13021	51939-005	DESIGN CHANGE	26-Jul-13
PCN13021	51939-005LF	DESIGN CHANGE	26-Jul-13
PCN13021	51939-006	DESIGN CHANGE	26-Jul-13
PCN13021	51939-006LF	DESIGN CHANGE	26-Jul-13
PCN13021	51939-007	DESIGN CHANGE	26-Jul-13
PCN13021	51939-008	DESIGN CHANGE	26-Jul-13
PCN13021	51939-011	DESIGN CHANGE	26-Jul-13
PCN13021	51939-011LF	DESIGN CHANGE	26-Jul-13
PCN13021	51939-012	DESIGN CHANGE	26-Jul-13
PCN13021	51939-012LF	DESIGN CHANGE	26-Jul-13
PCN13021	51939-013	DESIGN CHANGE	26-Jul-13
PCN13021	51939-014	DESIGN CHANGE	26-Jul-13
PCN13021	51939-014LF	DESIGN CHANGE	26-Jul-13
PCN13021	51939-015	DESIGN CHANGE	26-Jul-13
PCN13021	51939-015LF	DESIGN CHANGE	26-Jul-13
PCN13021	51939-016	DESIGN CHANGE	26-Jul-13
PCN13021	51939-016LF	DESIGN CHANGE	26-Jul-13
PCN13021	51939-017	DESIGN CHANGE	26-Jul-13
PCN13021	51939-018	DESIGN CHANGE	26-Jul-13
PCN13021	51939-020	DESIGN CHANGE	26-Jul-13
PCN13021	51939-022	DESIGN CHANGE	26-Jul-13
PCN13021	51939-022LF	DESIGN CHANGE	26-Jul-13
PCN13021	51939-023	DESIGN CHANGE	26-Jul-13
PCN13021	51939-023LF	DESIGN CHANGE	26-Jul-13
PCN13021	51939-025	DESIGN CHANGE	26-Jul-13
PCN13021	51939-025LF	DESIGN CHANGE	26-Jul-13
PCN13021	51939-026	DESIGN CHANGE	26-Jul-13
PCN13021	51939-026LF	DESIGN CHANGE	26-Jul-13
PCN13021	51939-027	DESIGN CHANGE	26-Jul-13
PCN13021	51939-028	DESIGN CHANGE	26-Jul-13
PCN13021	51939-029	DESIGN CHANGE	26-Jul-13
PCN13021	51939-030	DESIGN CHANGE	26-Jul-13
PCN13021	51939-030LF	DESIGN CHANGE	26-Jul-13
PCN13021	51939-031	DESIGN CHANGE	26-Jul-13
PCN13021	51939-031LF	DESIGN CHANGE	26-Jul-13
PCN13021	51939-032	DESIGN CHANGE	26-Jul-13
PCN13021	51939-032LF	DESIGN CHANGE	26-Jul-13
PCN13021	51939-033	DESIGN CHANGE	26-Jul-13

PCN13021	51939-034	DESIGN CHANGE	26-Jul-13
PCN13021	51939-035	DESIGN CHANGE	26-Jul-13
PCN13021	51939-037	DESIGN CHANGE	26-Jul-13
PCN13021	51939-037LF	DESIGN CHANGE	26-Jul-13
PCN13021	51939-038	DESIGN CHANGE	26-Jul-13
PCN13021	51939-039	DESIGN CHANGE	26-Jul-13
PCN13021	51939-041	DESIGN CHANGE	26-Jul-13
PCN13021	51939-041LF	DESIGN CHANGE	26-Jul-13
PCN13021	51939-042	DESIGN CHANGE	26-Jul-13
PCN13021	51939-042LF	DESIGN CHANGE	26-Jul-13
PCN13021	51939-043	DESIGN CHANGE	26-Jul-13
PCN13021	51939-043LF	DESIGN CHANGE	26-Jul-13
PCN13021	51939-044	DESIGN CHANGE	26-Jul-13
PCN13021	51939-044LF	DESIGN CHANGE	26-Jul-13
PCN13021	51939-045	DESIGN CHANGE	26-Jul-13
PCN13021	51939-045LF	DESIGN CHANGE	26-Jul-13
PCN13021	51939-046	DESIGN CHANGE	26-Jul-13
PCN13021	51939-046LF	DESIGN CHANGE	26-Jul-13
PCN13021	51939-047	DESIGN CHANGE	26-Jul-13
PCN13021	51939-049	DESIGN CHANGE	26-Jul-13
PCN13021	51939-049LF	DESIGN CHANGE	26-Jul-13
PCN13021	51939-050	DESIGN CHANGE	26-Jul-13
PCN13021	51939-051	DESIGN CHANGE	26-Jul-13
PCN13021	51939-052	DESIGN CHANGE	26-Jul-13
PCN13021	51939-052LF	DESIGN CHANGE	26-Jul-13
PCN13021	51939-054	DESIGN CHANGE	26-Jul-13
PCN13021	51939-055	DESIGN CHANGE	26-Jul-13
PCN13021	51939-055LF	DESIGN CHANGE	26-Jul-13
PCN13021	51939-056LF	DESIGN CHANGE	26-Jul-13
PCN13021	51939-057	DESIGN CHANGE	26-Jul-13
PCN13021	51939-058	DESIGN CHANGE	26-Jul-13
PCN13021	51939-060	DESIGN CHANGE	26-Jul-13
PCN13021	51939-060LF	DESIGN CHANGE	26-Jul-13
PCN13021	51939-061	DESIGN CHANGE	26-Jul-13
PCN13021	51939-062	DESIGN CHANGE	26-Jul-13
PCN13021	51939-062LF	DESIGN CHANGE	26-Jul-13
PCN13021	51939-063	DESIGN CHANGE	26-Jul-13
PCN13021	51939-064	DESIGN CHANGE	26-Jul-13
PCN13021	51939-065	DESIGN CHANGE	26-Jul-13
PCN13021	51939-065LF	DESIGN CHANGE	26-Jul-13
PCN13021	51939-066	DESIGN CHANGE	26-Jul-13

PCN13021	51939-066LF	DESIGN CHANGE	26-Jul-13
PCN13021	51939-067	DESIGN CHANGE	26-Jul-13
PCN13021	51939-067LF	DESIGN CHANGE	26-Jul-13
PCN13021	51939-068	DESIGN CHANGE	26-Jul-13
PCN13021	51939-069	DESIGN CHANGE	26-Jul-13
PCN13021	51939-069LF	DESIGN CHANGE	26-Jul-13
PCN13021	51939-070	DESIGN CHANGE	26-Jul-13
PCN13021	51939-070LF	DESIGN CHANGE	26-Jul-13
PCN13021	51939-071	DESIGN CHANGE	26-Jul-13
PCN13021	51939-072	DESIGN CHANGE	26-Jul-13
PCN13021	51939-072LF	DESIGN CHANGE	26-Jul-13
PCN13021	51939-073	DESIGN CHANGE	26-Jul-13
PCN13021	51939-074	DESIGN CHANGE	26-Jul-13
PCN13021	51939-074LF	DESIGN CHANGE	26-Jul-13
PCN13021	51939-075	DESIGN CHANGE	26-Jul-13
PCN13021	51939-076	DESIGN CHANGE	26-Jul-13
PCN13021	51939-078	DESIGN CHANGE	26-Jul-13
PCN13021	51939-079	DESIGN CHANGE	26-Jul-13
PCN13021	51939-079LF	DESIGN CHANGE	26-Jul-13
PCN13021	51939-080	DESIGN CHANGE	26-Jul-13
PCN13021	51939-083	DESIGN CHANGE	26-Jul-13
PCN13021	51939-083LF	DESIGN CHANGE	26-Jul-13
PCN13021	51939-084	DESIGN CHANGE	26-Jul-13
PCN13021	51939-084LF	DESIGN CHANGE	26-Jul-13
PCN13021	51939-086	DESIGN CHANGE	26-Jul-13
PCN13021	51939-086LF	DESIGN CHANGE	26-Jul-13
PCN13021	51939-087	DESIGN CHANGE	26-Jul-13
PCN13021	51939-088	DESIGN CHANGE	26-Jul-13
PCN13021	51939-089	DESIGN CHANGE	26-Jul-13
PCN13021	51939-090	DESIGN CHANGE	26-Jul-13
PCN13021	51939-090LF	DESIGN CHANGE	26-Jul-13
PCN13021	51939-091	DESIGN CHANGE	26-Jul-13
PCN13021	51939-092	DESIGN CHANGE	26-Jul-13
PCN13021	51939-092LF	DESIGN CHANGE	26-Jul-13
PCN13021	51939-093	DESIGN CHANGE	26-Jul-13
PCN13021	51939-094	DESIGN CHANGE	26-Jul-13
PCN13021	51939-095	DESIGN CHANGE	26-Jul-13
PCN13021	51939-095LF	DESIGN CHANGE	26-Jul-13
PCN13021	51939-096	DESIGN CHANGE	26-Jul-13
PCN13021	51939-096LF	DESIGN CHANGE	26-Jul-13
PCN13021	51939-097	DESIGN CHANGE	26-Jul-13

PCN13021	51939-098	DESIGN CHANGE	26-Jul-13
PCN13021	51939-098LF	DESIGN CHANGE	26-Jul-13
PCN13021	51939-099	DESIGN CHANGE	26-Jul-13
PCN13021	51939-100	DESIGN CHANGE	26-Jul-13
PCN13021	51939-101	DESIGN CHANGE	26-Jul-13
PCN13021	51939-102	DESIGN CHANGE	26-Jul-13
PCN13021	51939-103	DESIGN CHANGE	26-Jul-13
PCN13021	51939-103LF	DESIGN CHANGE	26-Jul-13
PCN13021	51939-104	DESIGN CHANGE	26-Jul-13
PCN13021	51939-104LF	DESIGN CHANGE	26-Jul-13
PCN13021	51939-105	DESIGN CHANGE	26-Jul-13
PCN13021	51939-105LF	DESIGN CHANGE	26-Jul-13
PCN13021	51939-106	DESIGN CHANGE	26-Jul-13
PCN13021	51939-107	DESIGN CHANGE	26-Jul-13
PCN13021	51939-107LF	DESIGN CHANGE	26-Jul-13
PCN13021	51939-108	DESIGN CHANGE	26-Jul-13
PCN13021	51939-109	DESIGN CHANGE	26-Jul-13
PCN13021	51939-110	DESIGN CHANGE	26-Jul-13
PCN13021	51939-111	DESIGN CHANGE	26-Jul-13
PCN13021	51939-111LF	DESIGN CHANGE	26-Jul-13
PCN13021	51939-112	DESIGN CHANGE	26-Jul-13
PCN13021	51939-112LF	DESIGN CHANGE	26-Jul-13
PCN13021	51939-113	DESIGN CHANGE	26-Jul-13
PCN13021	51939-114	DESIGN CHANGE	26-Jul-13
PCN13021	51939-114LF	DESIGN CHANGE	26-Jul-13
PCN13021	51939-115	DESIGN CHANGE	26-Jul-13
PCN13021	51939-115LF	DESIGN CHANGE	26-Jul-13
PCN13021	51939-116	DESIGN CHANGE	26-Jul-13
PCN13021	51939-117	DESIGN CHANGE	26-Jul-13
PCN13021	51939-118	DESIGN CHANGE	26-Jul-13
PCN13021	51939-118LF	DESIGN CHANGE	26-Jul-13
PCN13021	51939-119	DESIGN CHANGE	26-Jul-13
PCN13021	51939-119LF	DESIGN CHANGE	26-Jul-13
PCN13021	51939-120	DESIGN CHANGE	26-Jul-13
PCN13021	51939-122	DESIGN CHANGE	26-Jul-13
PCN13021	51939-122LF	DESIGN CHANGE	26-Jul-13
PCN13021	51939-123	DESIGN CHANGE	26-Jul-13
PCN13021	51939-123LF	DESIGN CHANGE	26-Jul-13
PCN13021	51939-124	DESIGN CHANGE	26-Jul-13
PCN13021	51939-124LF	DESIGN CHANGE	26-Jul-13
PCN13021	51939-127	DESIGN CHANGE	26-Jul-13

PCN13021	51939-128	DESIGN CHANGE	26-Jul-13
PCN13021	51939-130	DESIGN CHANGE	26-Jul-13
PCN13021	51939-130LF	DESIGN CHANGE	26-Jul-13
PCN13021	51939-131	DESIGN CHANGE	26-Jul-13
PCN13021	51939-131LF	DESIGN CHANGE	26-Jul-13
PCN13021	51939-132	DESIGN CHANGE	26-Jul-13
PCN13021	51939-132LF	DESIGN CHANGE	26-Jul-13
PCN13021	51939-133	DESIGN CHANGE	26-Jul-13
PCN13021	51939-134	DESIGN CHANGE	26-Jul-13
PCN13021	51939-134LF	DESIGN CHANGE	26-Jul-13
PCN13021	51939-135	DESIGN CHANGE	26-Jul-13
PCN13021	51939-135LF	DESIGN CHANGE	26-Jul-13
PCN13021	51939-136	DESIGN CHANGE	26-Jul-13
PCN13021	51939-136LF	DESIGN CHANGE	26-Jul-13
PCN13021	51939-137	DESIGN CHANGE	26-Jul-13
PCN13021	51939-137LF	DESIGN CHANGE	26-Jul-13
PCN13021	51939-138	DESIGN CHANGE	26-Jul-13
PCN13021	51939-138LF	DESIGN CHANGE	26-Jul-13
PCN13021	51939-139	DESIGN CHANGE	26-Jul-13
PCN13021	51939-139LF	DESIGN CHANGE	26-Jul-13
PCN13021	51939-140	DESIGN CHANGE	26-Jul-13
PCN13021	51939-140LF	DESIGN CHANGE	26-Jul-13
PCN13021	51939-142	DESIGN CHANGE	26-Jul-13
PCN13021	51939-145	DESIGN CHANGE	26-Jul-13
PCN13021	51939-146	DESIGN CHANGE	26-Jul-13
PCN13021	51939-147	DESIGN CHANGE	26-Jul-13
PCN13021	51939-147LF	DESIGN CHANGE	26-Jul-13
PCN13021	51939-148	DESIGN CHANGE	26-Jul-13
PCN13021	51939-148LF	DESIGN CHANGE	26-Jul-13
PCN13021	51939-149	DESIGN CHANGE	26-Jul-13
PCN13021	51939-149LF	DESIGN CHANGE	26-Jul-13
PCN13021	51939-151	DESIGN CHANGE	26-Jul-13
PCN13021	51939-152	DESIGN CHANGE	26-Jul-13
PCN13021	51939-152LF	DESIGN CHANGE	26-Jul-13
PCN13021	51939-153LF	DESIGN CHANGE	26-Jul-13
PCN13021	51939-154	DESIGN CHANGE	26-Jul-13
PCN13021	51939-154LF	DESIGN CHANGE	26-Jul-13
PCN13021	51939-156	DESIGN CHANGE	26-Jul-13
PCN13021	51939-156LF	DESIGN CHANGE	26-Jul-13
PCN13021	51939-157	DESIGN CHANGE	26-Jul-13
PCN13021	51939-157LF	DESIGN CHANGE	26-Jul-13



PCN13021	51939-158LF	DESIGN CHANGE	26-Jul-13
PCN13021	51939-159	DESIGN CHANGE	26-Jul-13
PCN13021	51939-159LF	DESIGN CHANGE	26-Jul-13
PCN13021	51939-160	DESIGN CHANGE	26-Jul-13
PCN13021	51939-160LF	DESIGN CHANGE	26-Jul-13
PCN13021	51939-161	DESIGN CHANGE	26-Jul-13
PCN13021	51939-161LF	DESIGN CHANGE	26-Jul-13
PCN13021	51939-163	DESIGN CHANGE	26-Jul-13
PCN13021	51939-163LF	DESIGN CHANGE	26-Jul-13
PCN13021	51939-165	DESIGN CHANGE	26-Jul-13
PCN13021	51939-166LF	DESIGN CHANGE	26-Jul-13
PCN13021	51939-171LF	DESIGN CHANGE	26-Jul-13
PCN13021	51939-173	DESIGN CHANGE	26-Jul-13
PCN13021	51939-173LF	DESIGN CHANGE	26-Jul-13
PCN13021	51939-178	DESIGN CHANGE	26-Jul-13
PCN13021	51939-178LF	DESIGN CHANGE	26-Jul-13
PCN13021	51939-179	DESIGN CHANGE	26-Jul-13
PCN13021	51939-179LF	DESIGN CHANGE	26-Jul-13
PCN13021	51939-180	DESIGN CHANGE	26-Jul-13
PCN13021	51939-180LF	DESIGN CHANGE	26-Jul-13
PCN13021	51939-181	DESIGN CHANGE	26-Jul-13
PCN13021	51939-181LF	DESIGN CHANGE	26-Jul-13
PCN13021	51939-182	DESIGN CHANGE	26-Jul-13
PCN13021	51939-182LF	DESIGN CHANGE	26-Jul-13
PCN13021	51939-183	DESIGN CHANGE	26-Jul-13
PCN13021	51939-183LF	DESIGN CHANGE	26-Jul-13
PCN13021	51939-184LF	DESIGN CHANGE	26-Jul-13
PCN13021	51939-185	DESIGN CHANGE	26-Jul-13
PCN13021	51939-185LF	DESIGN CHANGE	26-Jul-13
PCN13021	51939-186	DESIGN CHANGE	26-Jul-13
PCN13021	51939-186LF	DESIGN CHANGE	26-Jul-13
PCN13021	51939-189	DESIGN CHANGE	26-Jul-13
PCN13021	51939-189LF	DESIGN CHANGE	26-Jul-13
PCN13021	51939-190	DESIGN CHANGE	26-Jul-13
PCN13021	51939-190LF	DESIGN CHANGE	26-Jul-13
PCN13021	51939-191	DESIGN CHANGE	26-Jul-13
PCN13021	51939-192	DESIGN CHANGE	26-Jul-13
PCN13021	51939-192LF	DESIGN CHANGE	26-Jul-13
PCN13021	51939-193	DESIGN CHANGE	26-Jul-13
PCN13021	51939-193LF	DESIGN CHANGE	26-Jul-13
PCN13021	51939-195	DESIGN CHANGE	26-Jul-13

PCN13021	51939-197	DESIGN CHANGE	26-Jul-13
PCN13021	51939-197LF	DESIGN CHANGE	26-Jul-13
PCN13021	51939-199	DESIGN CHANGE	26-Jul-13
PCN13021	51939-199LF	DESIGN CHANGE	26-Jul-13
PCN13021	51939-203	DESIGN CHANGE	26-Jul-13
PCN13021	51939-203LF	DESIGN CHANGE	26-Jul-13
PCN13021	51939-204LF	DESIGN CHANGE	26-Jul-13
PCN13021	51939-205	DESIGN CHANGE	26-Jul-13
PCN13021	51939-207	DESIGN CHANGE	26-Jul-13
PCN13021	51939-207LF	DESIGN CHANGE	26-Jul-13
PCN13021	51939-209	DESIGN CHANGE	26-Jul-13
PCN13021	51939-209LF	DESIGN CHANGE	26-Jul-13
PCN13021	51939-210LF	DESIGN CHANGE	26-Jul-13
PCN13021	51939-211LF	DESIGN CHANGE	26-Jul-13
PCN13021	51939-213	DESIGN CHANGE	26-Jul-13
PCN13021	51939-213LF	DESIGN CHANGE	26-Jul-13
PCN13021	51939-214	DESIGN CHANGE	26-Jul-13
PCN13021	51939-214LF	DESIGN CHANGE	26-Jul-13
PCN13021	51939-215LF	DESIGN CHANGE	26-Jul-13
PCN13021	51939-218LF	DESIGN CHANGE	26-Jul-13
PCN13021	51939-220	DESIGN CHANGE	26-Jul-13
PCN13021	51939-222	DESIGN CHANGE	26-Jul-13
PCN13021	51939-223LF	DESIGN CHANGE	26-Jul-13
PCN13021	51939-224LF	DESIGN CHANGE	26-Jul-13
PCN13021	51939-227	DESIGN CHANGE	26-Jul-13
PCN13021	51939-227LF	DESIGN CHANGE	26-Jul-13
PCN13021	51939-228LF	DESIGN CHANGE	26-Jul-13
PCN13021	51939-230	DESIGN CHANGE	26-Jul-13
PCN13021	51939-230LF	DESIGN CHANGE	26-Jul-13
PCN13021	51939-232LF	DESIGN CHANGE	26-Jul-13
PCN13021	51939-233LF	DESIGN CHANGE	26-Jul-13
PCN13021	51939-234LF	DESIGN CHANGE	26-Jul-13
PCN13021	51939-235LF	DESIGN CHANGE	26-Jul-13
PCN13021	51939-236	DESIGN CHANGE	26-Jul-13
PCN13021	51939-237	DESIGN CHANGE	26-Jul-13
PCN13021	51939-239LF	DESIGN CHANGE	26-Jul-13
PCN13021	51939-240LF	DESIGN CHANGE	26-Jul-13
PCN13021	51939-241	DESIGN CHANGE	26-Jul-13
PCN13021	51939-247LF	DESIGN CHANGE	26-Jul-13
PCN13021	51939-248	DESIGN CHANGE	26-Jul-13
PCN13021	51939-248LF	DESIGN CHANGE	26-Jul-13

PCN13021	51939-255LF	DESIGN CHANGE	26-Jul-13
PCN13021	51939-256	DESIGN CHANGE	26-Jul-13
PCN13021	51939-256LF	DESIGN CHANGE	26-Jul-13
PCN13021	51939-257	DESIGN CHANGE	26-Jul-13
PCN13021	51939-257LF	DESIGN CHANGE	26-Jul-13
PCN13021	51939-258	DESIGN CHANGE	26-Jul-13
PCN13021	51939-258LF	DESIGN CHANGE	26-Jul-13
PCN13021	51939-259	DESIGN CHANGE	26-Jul-13
PCN13021	51939-259LF	DESIGN CHANGE	26-Jul-13
PCN13021	51939-261	DESIGN CHANGE	26-Jul-13
PCN13021	51939-261LF	DESIGN CHANGE	26-Jul-13
PCN13021	51939-262	DESIGN CHANGE	26-Jul-13
PCN13021	51939-262LF	DESIGN CHANGE	26-Jul-13
PCN13021	51939-265LF	DESIGN CHANGE	26-Jul-13
PCN13021	51939-266	DESIGN CHANGE	26-Jul-13
PCN13021	51939-266LF	DESIGN CHANGE	26-Jul-13
PCN13021	51939-267	DESIGN CHANGE	26-Jul-13
PCN13021	51939-267LF	DESIGN CHANGE	26-Jul-13
PCN13021	51939-268LF	DESIGN CHANGE	26-Jul-13
PCN13021	51939-271LF	DESIGN CHANGE	26-Jul-13
PCN13021	51939-273LF	DESIGN CHANGE	26-Jul-13
PCN13021	51939-274LF	DESIGN CHANGE	26-Jul-13
PCN13021	51939-275LF	DESIGN CHANGE	26-Jul-13
PCN13021	51939-278	DESIGN CHANGE	26-Jul-13
PCN13021	51939-278LF	DESIGN CHANGE	26-Jul-13
PCN13021	51939-279	DESIGN CHANGE	26-Jul-13
PCN13021	51939-279LF	DESIGN CHANGE	26-Jul-13
PCN13021	51939-280LF	DESIGN CHANGE	26-Jul-13
PCN13021	51939-281LF	DESIGN CHANGE	26-Jul-13
PCN13021	51939-282LF	DESIGN CHANGE	26-Jul-13
PCN13021	51939-283LF	DESIGN CHANGE	26-Jul-13
PCN13021	51939-284LF	DESIGN CHANGE	26-Jul-13
PCN13021	51939-285	DESIGN CHANGE	26-Jul-13
PCN13021	51939-285LF	DESIGN CHANGE	26-Jul-13
PCN13021	51939-286LF	DESIGN CHANGE	26-Jul-13
PCN13021	51939-290LF	DESIGN CHANGE	26-Jul-13
PCN13021	51939-291LF	DESIGN CHANGE	26-Jul-13
PCN13021	51939-292LF	DESIGN CHANGE	26-Jul-13
PCN13021	51939-293LF	DESIGN CHANGE	26-Jul-13
PCN13021	51939-295LF	DESIGN CHANGE	26-Jul-13
PCN13021	51939-296LF	DESIGN CHANGE	26-Jul-13

PCN13021	51939-298LF	DESIGN CHANGE	26-Jul-13
PCN13021	51939-299LF	DESIGN CHANGE	26-Jul-13
PCN13021	51939-300LF	DESIGN CHANGE	26-Jul-13
PCN13021	51939-301LF	DESIGN CHANGE	26-Jul-13
PCN13021	51939-302LF	DESIGN CHANGE	26-Jul-13
PCN13021	51939-303	DESIGN CHANGE	26-Jul-13
PCN13021	51939-303LF	DESIGN CHANGE	26-Jul-13
PCN13021	51939-305LF	DESIGN CHANGE	26-Jul-13
PCN13021	51939-306LF	DESIGN CHANGE	26-Jul-13
PCN13021	51939-307LF	DESIGN CHANGE	26-Jul-13
PCN13021	51939-308LF	DESIGN CHANGE	26-Jul-13
PCN13021	51939-309LF	DESIGN CHANGE	26-Jul-13
PCN13021	51939-310LF	DESIGN CHANGE	26-Jul-13
PCN13021	51939-313LF	DESIGN CHANGE	26-Jul-13
PCN13021	51939-314LF	DESIGN CHANGE	26-Jul-13
PCN13021	51939-315LF	DESIGN CHANGE	26-Jul-13
PCN13021	51939-316LF	DESIGN CHANGE	26-Jul-13
PCN13021	51939-317LF	DESIGN CHANGE	26-Jul-13
PCN13021	51939-318LF	DESIGN CHANGE	26-Jul-13
PCN13021	51939-319LF	DESIGN CHANGE	26-Jul-13
PCN13021	51939-321LF	DESIGN CHANGE	26-Jul-13
PCN13021	51939-322LF	DESIGN CHANGE	26-Jul-13
PCN13021	51939-323LF	DESIGN CHANGE	26-Jul-13
PCN13021	51939-324LF	DESIGN CHANGE	26-Jul-13
PCN13021	51939-325LF	DESIGN CHANGE	26-Jul-13
PCN13021	51939-326LF	DESIGN CHANGE	26-Jul-13
PCN13021	51939-327LF	DESIGN CHANGE	26-Jul-13
PCN13021	51939-329LF	DESIGN CHANGE	26-Jul-13
PCN13021	51939-330LF	DESIGN CHANGE	26-Jul-13
PCN13021	51939-331	DESIGN CHANGE	26-Jul-13
PCN13021	51939-331LF	DESIGN CHANGE	26-Jul-13
PCN13021	51939-332LF	DESIGN CHANGE	26-Jul-13
PCN13021	51939-333LF	DESIGN CHANGE	26-Jul-13
PCN13021	51939-339LF	DESIGN CHANGE	26-Jul-13
PCN13021	51939-340LF	DESIGN CHANGE	26-Jul-13
PCN13021	51939-341LF	DESIGN CHANGE	26-Jul-13
PCN13021	51939-342LF	DESIGN CHANGE	26-Jul-13
PCN13021	51939-343LF	DESIGN CHANGE	26-Jul-13
PCN13021	51939-347LF	DESIGN CHANGE	26-Jul-13
PCN13021	51939-348LF	DESIGN CHANGE	26-Jul-13
PCN13021	51939-349	DESIGN CHANGE	26-Jul-13

PCN13021	51939-349LF	DESIGN CHANGE	26-Jul-13
PCN13021	51939-350LF	DESIGN CHANGE	26-Jul-13
PCN13021	51939-351LF	DESIGN CHANGE	26-Jul-13
PCN13021	51939-354LF	DESIGN CHANGE	26-Jul-13
PCN13021	51939-355LF	DESIGN CHANGE	26-Jul-13
PCN13021	51939-357LF	DESIGN CHANGE	26-Jul-13
PCN13021	51939-358LF	DESIGN CHANGE	26-Jul-13
PCN13021	51939-360LF	DESIGN CHANGE	26-Jul-13
PCN13021	51939-361LF	DESIGN CHANGE	26-Jul-13
PCN13021	51939-362LF	DESIGN CHANGE	26-Jul-13
PCN13021	51939-367LF	DESIGN CHANGE	26-Jul-13
PCN13021	51939-368LF	DESIGN CHANGE	26-Jul-13
PCN13021	51939-371LF	DESIGN CHANGE	26-Jul-13
PCN13021	51939-372LF	DESIGN CHANGE	26-Jul-13
PCN13021	51939-374LF	DESIGN CHANGE	26-Jul-13
PCN13021	51939-375	DESIGN CHANGE	26-Jul-13
PCN13021	51939-375LF	DESIGN CHANGE	26-Jul-13
PCN13021	51939-376LF	DESIGN CHANGE	26-Jul-13
PCN13021	51939-377LF	DESIGN CHANGE	26-Jul-13
PCN13021	51939-379LF	DESIGN CHANGE	26-Jul-13
PCN13021	51939-380LF	DESIGN CHANGE	26-Jul-13
PCN13021	51939-383LF	DESIGN CHANGE	26-Jul-13
PCN13021	51939-384LF	DESIGN CHANGE	26-Jul-13
PCN13021	51939-386LF	DESIGN CHANGE	26-Jul-13
PCN13021	51939-387LF	DESIGN CHANGE	26-Jul-13
PCN13021	51939-392LF	DESIGN CHANGE	26-Jul-13
PCN13021	51939-393LF	DESIGN CHANGE	26-Jul-13
PCN13021	51939-394LF	DESIGN CHANGE	26-Jul-13
PCN13021	51939-397LF	DESIGN CHANGE	26-Jul-13
PCN13021	51939-400LF	DESIGN CHANGE	26-Jul-13
PCN13021	51939-401LF	DESIGN CHANGE	26-Jul-13
PCN13021	51939-402LF	DESIGN CHANGE	26-Jul-13
PCN13021	51939-404LF	DESIGN CHANGE	26-Jul-13
PCN13021	51939-405LF	DESIGN CHANGE	26-Jul-13
PCN13021	51939-409LF	DESIGN CHANGE	26-Jul-13
PCN13021	51939-410LF	DESIGN CHANGE	26-Jul-13
PCN13021	51939-411LF	DESIGN CHANGE	26-Jul-13
PCN13021	51939-415LF	DESIGN CHANGE	26-Jul-13
PCN13021	51939-419LF	DESIGN CHANGE	26-Jul-13
PCN13021	51939-420LF	DESIGN CHANGE	26-Jul-13
PCN13021	51939-423LF	DESIGN CHANGE	26-Jul-13

PCN13021	51939-424LF	DESIGN CHANGE	26-Jul-13
PCN13021	51939-425LF	DESIGN CHANGE	26-Jul-13
PCN13021	51939-428LF	DESIGN CHANGE	26-Jul-13
PCN13021	51939-429LF	DESIGN CHANGE	26-Jul-13
PCN13021	51939-430LF	DESIGN CHANGE	26-Jul-13
PCN13021	51939-431LF	DESIGN CHANGE	26-Jul-13
PCN13021	51939-432LF	DESIGN CHANGE	26-Jul-13
PCN13021	51939-433LF	DESIGN CHANGE	26-Jul-13
PCN13021	51939-437LF	DESIGN CHANGE	26-Jul-13
PCN13021	51939-438LF	DESIGN CHANGE	26-Jul-13
PCN13021	51939-439LF	DESIGN CHANGE	26-Jul-13
PCN13021	51939-440LF	DESIGN CHANGE	26-Jul-13
PCN13021	51939-443LF	DESIGN CHANGE	26-Jul-13
PCN13021	51939-444LF	DESIGN CHANGE	26-Jul-13
PCN13021	51939-448LF	DESIGN CHANGE	26-Jul-13
PCN13021	51939-451LF	DESIGN CHANGE	26-Jul-13
PCN13021	51939-453LF	DESIGN CHANGE	26-Jul-13
PCN13021	51939-455LF	DESIGN CHANGE	26-Jul-13
PCN13021	51939-456LF	DESIGN CHANGE	26-Jul-13
PCN13021	51939-458LF	DESIGN CHANGE	26-Jul-13
PCN13021	51939-460LF	DESIGN CHANGE	26-Jul-13
PCN13021	51939-461LF	DESIGN CHANGE	26-Jul-13
PCN13021	51939-465LF	DESIGN CHANGE	26-Jul-13
PCN13021	51939-467LF	DESIGN CHANGE	26-Jul-13
PCN13021	51939-468LF	DESIGN CHANGE	26-Jul-13
PCN13021	51939-469LF	DESIGN CHANGE	26-Jul-13
PCN13021	51939-470LF	DESIGN CHANGE	26-Jul-13
PCN13021	51939-472LF	DESIGN CHANGE	26-Jul-13
PCN13021	51939-473LF	DESIGN CHANGE	26-Jul-13
PCN13021	51939-474LF	DESIGN CHANGE	26-Jul-13
PCN13021	51939-476LF	DESIGN CHANGE	26-Jul-13
PCN13021	51939-481LF	DESIGN CHANGE	26-Jul-13
PCN13021	51939-482LF	DESIGN CHANGE	26-Jul-13
PCN13021	51939-483LF	DESIGN CHANGE	26-Jul-13
PCN13021	51939-486LF	DESIGN CHANGE	26-Jul-13
PCN13021	51939-490LF	DESIGN CHANGE	26-Jul-13
PCN13021	51939-491LF	DESIGN CHANGE	26-Jul-13
PCN13021	51939-495LF	DESIGN CHANGE	26-Jul-13
PCN13021	51939-496LF	DESIGN CHANGE	26-Jul-13
PCN13021	51939-500LF	DESIGN CHANGE	26-Jul-13
PCN13021	51939-501LF	DESIGN CHANGE	26-Jul-13

PCN13021	51939-502LF	DESIGN CHANGE	26-Jul-13
PCN13021	51939-504LF	DESIGN CHANGE	26-Jul-13
PCN13021	51939-505LF	DESIGN CHANGE	26-Jul-13
PCN13021	51939-506LF	DESIGN CHANGE	26-Jul-13
PCN13021	51939-507LF	DESIGN CHANGE	26-Jul-13
PCN13021	51939-508LF	DESIGN CHANGE	26-Jul-13
PCN13021	51939-511LF	DESIGN CHANGE	26-Jul-13
PCN13021	51939-512LF	DESIGN CHANGE	26-Jul-13
PCN13021	51939-513LF	DESIGN CHANGE	26-Jul-13
PCN13021	51939-515LF	DESIGN CHANGE	26-Jul-13
PCN13021	51939-516LF	DESIGN CHANGE	26-Jul-13
PCN13021	51939-517LF	DESIGN CHANGE	26-Jul-13
PCN13021	51939-522LF	DESIGN CHANGE	26-Jul-13
PCN13021	51939-524LF	DESIGN CHANGE	26-Jul-13
PCN13021	51939-524LFDG	DESIGN CHANGE	26-Jul-13
PCN13021	51939-525LF	DESIGN CHANGE	26-Jul-13
PCN13021	51939-531LF	DESIGN CHANGE	26-Jul-13
PCN13021	51939-533LF	DESIGN CHANGE	26-Jul-13
PCN13021	51939-535LF	DESIGN CHANGE	26-Jul-13
PCN13021	51939-536LF	DESIGN CHANGE	26-Jul-13
PCN13021	51939-537LF	DESIGN CHANGE	26-Jul-13
PCN13021	51939-541LF	DESIGN CHANGE	26-Jul-13
PCN13021	51939-543LF	DESIGN CHANGE	26-Jul-13
PCN13021	51939-544LF	DESIGN CHANGE	26-Jul-13
PCN13021	51939-546LF	DESIGN CHANGE	26-Jul-13
PCN13021	51939-548LF	DESIGN CHANGE	26-Jul-13
PCN13021	51939-552LF	DESIGN CHANGE	26-Jul-13
PCN13021	51939-553LF	DESIGN CHANGE	26-Jul-13
PCN13021	51939-557LF	DESIGN CHANGE	26-Jul-13
PCN13021	51939-558LF	DESIGN CHANGE	26-Jul-13
PCN13021	51939-561LF	DESIGN CHANGE	26-Jul-13
PCN13021	51939-563LF	DESIGN CHANGE	26-Jul-13
PCN13021	51939-564LF	DESIGN CHANGE	26-Jul-13
PCN13021	51939-565LF	DESIGN CHANGE	26-Jul-13
PCN13021	51939-566LF	DESIGN CHANGE	26-Jul-13
PCN13021	51939-568LF	DESIGN CHANGE	26-Jul-13
PCN13021	51939-569LF	DESIGN CHANGE	26-Jul-13
PCN13021	51939-571LF	DESIGN CHANGE	26-Jul-13
PCN13021	51939-573LF	DESIGN CHANGE	26-Jul-13
PCN13021	51939-576LF	DESIGN CHANGE	26-Jul-13
PCN13021	51939-577LF	DESIGN CHANGE	26-Jul-13

PCN13021	51939-578LF	DESIGN CHANGE	26-Jul-13
PCN13021	51939-579LF	DESIGN CHANGE	26-Jul-13
PCN13021	51939-580LF	DESIGN CHANGE	26-Jul-13
PCN13021	51939-581LF	DESIGN CHANGE	26-Jul-13
PCN13021	51939-582LF	DESIGN CHANGE	26-Jul-13
PCN13021	51939-586LF	DESIGN CHANGE	26-Jul-13
PCN13021	51939-587LF	DESIGN CHANGE	26-Jul-13
PCN13021	51939-589LF	DESIGN CHANGE	26-Jul-13
PCN13021	51939-590LF	DESIGN CHANGE	26-Jul-13
PCN13021	51939-592LF	DESIGN CHANGE	26-Jul-13
PCN13021	51939-594LF	DESIGN CHANGE	26-Jul-13
PCN13021	51939-595LF	DESIGN CHANGE	26-Jul-13
PCN13021	51939-597LF	DESIGN CHANGE	26-Jul-13
PCN13021	51939-598LF	DESIGN CHANGE	26-Jul-13
PCN13021	51939-599LF	DESIGN CHANGE	26-Jul-13
PCN13021	51939-608LF	DESIGN CHANGE	26-Jul-13
PCN13021	51939-611LF	DESIGN CHANGE	26-Jul-13
PCN13021	51939-614LF	DESIGN CHANGE	26-Jul-13
PCN13021	51939-617LF	DESIGN CHANGE	26-Jul-13
PCN13021	51939-618LF	DESIGN CHANGE	26-Jul-13
PCN13021	51939-619LF	DESIGN CHANGE	26-Jul-13
PCN13021	51939-620LF	DESIGN CHANGE	26-Jul-13
PCN13021	51939-622LF	DESIGN CHANGE	26-Jul-13
PCN13021	51939-623LF	DESIGN CHANGE	26-Jul-13
PCN13021	51939-629LF	DESIGN CHANGE	26-Jul-13
PCN13021	51939-631LF	DESIGN CHANGE	26-Jul-13
PCN13021	51939-633LF	DESIGN CHANGE	26-Jul-13
PCN13021	51939-636LF	DESIGN CHANGE	26-Jul-13
PCN13021	51939-641LF	DESIGN CHANGE	26-Jul-13
PCN13021	51939-642LF	DESIGN CHANGE	26-Jul-13
PCN13021	51939-646LF	DESIGN CHANGE	26-Jul-13
PCN13021	51939-647LF	DESIGN CHANGE	26-Jul-13
PCN13021	51939-648LF	DESIGN CHANGE	26-Jul-13
PCN13021	51939-653LF	DESIGN CHANGE	26-Jul-13
PCN13021	51939-654LF	DESIGN CHANGE	26-Jul-13
PCN13021	51939-655LF	DESIGN CHANGE	26-Jul-13
PCN13021	51939-660LF	DESIGN CHANGE	26-Jul-13
PCN13021	51939-661LF	DESIGN CHANGE	26-Jul-13
PCN13021	51939-662LF	DESIGN CHANGE	26-Jul-13
PCN13021	51939-663LF	DESIGN CHANGE	26-Jul-13
PCN13021	51939-665LF	DESIGN CHANGE	26-Jul-13



PCN13021	51939-666LF	DESIGN CHANGE	26-Jul-13
PCN13021	51939-667LF	DESIGN CHANGE	26-Jul-13
PCN13021	51939-669LF	DESIGN CHANGE	26-Jul-13
PCN13021	51939-674LF	DESIGN CHANGE	26-Jul-13
PCN13021	51939-675LF	DESIGN CHANGE	26-Jul-13
PCN13021	51939-676PLF	DESIGN CHANGE	26-Jul-13
PCN13021	51939-679LF	DESIGN CHANGE	26-Jul-13
PCN13021	51939-681LF	DESIGN CHANGE	26-Jul-13
PCN13021	51939-682LF	DESIGN CHANGE	26-Jul-13
PCN13021	51939-683LF	DESIGN CHANGE	26-Jul-13
PCN13021	51939-687	DESIGN CHANGE	26-Jul-13
PCN13021	51939-689LF	DESIGN CHANGE	26-Jul-13
PCN13021	51939-691LF	DESIGN CHANGE	26-Jul-13
PCN13021	51939-692LF	DESIGN CHANGE	26-Jul-13
PCN13021	51939-695LF	DESIGN CHANGE	26-Jul-13
PCN13021	51939-697LF	DESIGN CHANGE	26-Jul-13
PCN13021	51939-698LF	DESIGN CHANGE	26-Jul-13
PCN13021	51939-699LF	DESIGN CHANGE	26-Jul-13
PCN13021	51939-700LF	DESIGN CHANGE	26-Jul-13
PCN13021	51939-701LF	DESIGN CHANGE	26-Jul-13
PCN13021	51939-704LF	DESIGN CHANGE	26-Jul-13
PCN13021	51939-705LF	DESIGN CHANGE	26-Jul-13
PCN13021	51939-707LF	DESIGN CHANGE	26-Jul-13
PCN13021	51939-709LF	DESIGN CHANGE	26-Jul-13
PCN13021	51939-710LF	DESIGN CHANGE	26-Jul-13
PCN13021	51939-711LF	DESIGN CHANGE	26-Jul-13
PCN13021	51939-712LF	DESIGN CHANGE	26-Jul-13
PCN13021	51939-713LF	DESIGN CHANGE	26-Jul-13
PCN13021	51939-715LF	DESIGN CHANGE	26-Jul-13
PCN13021	51939-717LF	DESIGN CHANGE	26-Jul-13
PCN13021	51939-718LF	DESIGN CHANGE	26-Jul-13
PCN13021	51939-721LF	DESIGN CHANGE	26-Jul-13
PCN13021	51939-722LF	DESIGN CHANGE	26-Jul-13
PCN13021	51939-723LF	DESIGN CHANGE	26-Jul-13
PCN13021	51939-726LF	DESIGN CHANGE	26-Jul-13
PCN13021	51939-727LF	DESIGN CHANGE	26-Jul-13
PCN13021	51939-730LF	DESIGN CHANGE	26-Jul-13
PCN13021	51939-731LF	DESIGN CHANGE	26-Jul-13
PCN13021	51939-734LF	DESIGN CHANGE	26-Jul-13
PCN13021	51939-736LF	DESIGN CHANGE	26-Jul-13
PCN13021	51940-001	DESIGN CHANGE	26-Jul-13

PCN13021	51940-002	DESIGN CHANGE	26-Jul-13
PCN13021	51940-003	DESIGN CHANGE	26-Jul-13
PCN13021	51940-004	DESIGN CHANGE	26-Jul-13
PCN13021	51940-005	DESIGN CHANGE	26-Jul-13
PCN13021	51940-007	DESIGN CHANGE	26-Jul-13
PCN13021	51940-007LF	DESIGN CHANGE	26-Jul-13
PCN13021	51940-009	DESIGN CHANGE	26-Jul-13
PCN13021	51940-009LF	DESIGN CHANGE	26-Jul-13
PCN13021	51940-010	DESIGN CHANGE	26-Jul-13
PCN13021	51940-010LF	DESIGN CHANGE	26-Jul-13
PCN13021	51940-011	DESIGN CHANGE	26-Jul-13
PCN13021	51940-012	DESIGN CHANGE	26-Jul-13
PCN13021	51940-013	DESIGN CHANGE	26-Jul-13
PCN13021	51940-016	DESIGN CHANGE	26-Jul-13
PCN13021	51940-016LF	DESIGN CHANGE	26-Jul-13
PCN13021	51940-017	DESIGN CHANGE	26-Jul-13
PCN13021	51940-018	DESIGN CHANGE	26-Jul-13
PCN13021	51940-019	DESIGN CHANGE	26-Jul-13
PCN13021	51940-020	DESIGN CHANGE	26-Jul-13
PCN13021	51940-021	DESIGN CHANGE	26-Jul-13
PCN13021	51940-022	DESIGN CHANGE	26-Jul-13
PCN13021	51940-022LF	DESIGN CHANGE	26-Jul-13
PCN13021	51940-023	DESIGN CHANGE	26-Jul-13
PCN13021	51940-024	DESIGN CHANGE	26-Jul-13
PCN13021	51940-024LF	DESIGN CHANGE	26-Jul-13
PCN13021	51940-025	DESIGN CHANGE	26-Jul-13
PCN13021	51940-026	DESIGN CHANGE	26-Jul-13
PCN13021	51940-027	DESIGN CHANGE	26-Jul-13
PCN13021	51940-027LF	DESIGN CHANGE	26-Jul-13
PCN13021	51940-028	DESIGN CHANGE	26-Jul-13
PCN13021	51940-028LF	DESIGN CHANGE	26-Jul-13
PCN13021	51940-029	DESIGN CHANGE	26-Jul-13
PCN13021	51940-030	DESIGN CHANGE	26-Jul-13
PCN13021	51940-030LF	DESIGN CHANGE	26-Jul-13
PCN13021	51940-031	DESIGN CHANGE	26-Jul-13
PCN13021	51940-031LF	DESIGN CHANGE	26-Jul-13
PCN13021	51940-032	DESIGN CHANGE	26-Jul-13
PCN13021	51940-032LF	DESIGN CHANGE	26-Jul-13
PCN13021	51940-033	DESIGN CHANGE	26-Jul-13
PCN13021	51940-034	DESIGN CHANGE	26-Jul-13
PCN13021	51940-035	DESIGN CHANGE	26-Jul-13

PCN13021	51940-035LF	DESIGN CHANGE	26-Jul-13
PCN13021	51940-037	DESIGN CHANGE	26-Jul-13
PCN13021	51940-038	DESIGN CHANGE	26-Jul-13
PCN13021	51940-038LF	DESIGN CHANGE	26-Jul-13
PCN13021	51940-040	DESIGN CHANGE	26-Jul-13
PCN13021	51940-041	DESIGN CHANGE	26-Jul-13
PCN13021	51940-042	DESIGN CHANGE	26-Jul-13
PCN13021	51940-042LF	DESIGN CHANGE	26-Jul-13
PCN13021	51940-043	DESIGN CHANGE	26-Jul-13
PCN13021	51940-043LF	DESIGN CHANGE	26-Jul-13
PCN13021	51940-044	DESIGN CHANGE	26-Jul-13
PCN13021	51940-045	DESIGN CHANGE	26-Jul-13
PCN13021	51940-046	DESIGN CHANGE	26-Jul-13
PCN13021	51940-046LF	DESIGN CHANGE	26-Jul-13
PCN13021	51940-047	DESIGN CHANGE	26-Jul-13
PCN13021	51940-048	DESIGN CHANGE	26-Jul-13
PCN13021	51940-051	DESIGN CHANGE	26-Jul-13
PCN13021	51940-052	DESIGN CHANGE	26-Jul-13
PCN13021	51940-053	DESIGN CHANGE	26-Jul-13
PCN13021	51940-053LF	DESIGN CHANGE	26-Jul-13
PCN13021	51940-054	DESIGN CHANGE	26-Jul-13
PCN13021	51940-054LF	DESIGN CHANGE	26-Jul-13
PCN13021	51940-055	DESIGN CHANGE	26-Jul-13
PCN13021	51940-056	DESIGN CHANGE	26-Jul-13
PCN13021	51940-057	DESIGN CHANGE	26-Jul-13
PCN13021	51940-058	DESIGN CHANGE	26-Jul-13
PCN13021	51940-058LF	DESIGN CHANGE	26-Jul-13
PCN13021	51940-060	DESIGN CHANGE	26-Jul-13
PCN13021	51940-061	DESIGN CHANGE	26-Jul-13
PCN13021	51940-062LF	DESIGN CHANGE	26-Jul-13
PCN13021	51940-063	DESIGN CHANGE	26-Jul-13
PCN13021	51940-063LF	DESIGN CHANGE	26-Jul-13
PCN13021	51940-064	DESIGN CHANGE	26-Jul-13
PCN13021	51940-067	DESIGN CHANGE	26-Jul-13
PCN13021	51940-067LF	DESIGN CHANGE	26-Jul-13
PCN13021	51940-068	DESIGN CHANGE	26-Jul-13
PCN13021	51940-069	DESIGN CHANGE	26-Jul-13
PCN13021	51940-070	DESIGN CHANGE	26-Jul-13
PCN13021	51940-071	DESIGN CHANGE	26-Jul-13
PCN13021	51940-072	DESIGN CHANGE	26-Jul-13
PCN13021	51940-072LF	DESIGN CHANGE	26-Jul-13

PCN13021	51940-073	DESIGN CHANGE	26-Jul-13
PCN13021	51940-074	DESIGN CHANGE	26-Jul-13
PCN13021	51940-075	DESIGN CHANGE	26-Jul-13
PCN13021	51940-075LF	DESIGN CHANGE	26-Jul-13
PCN13021	51940-077	DESIGN CHANGE	26-Jul-13
PCN13021	51940-078	DESIGN CHANGE	26-Jul-13
PCN13021	51940-079	DESIGN CHANGE	26-Jul-13
PCN13021	51940-080	DESIGN CHANGE	26-Jul-13
PCN13021	51940-081	DESIGN CHANGE	26-Jul-13
PCN13021	51940-082	DESIGN CHANGE	26-Jul-13
PCN13021	51940-082LF	DESIGN CHANGE	26-Jul-13
PCN13021	51940-083	DESIGN CHANGE	26-Jul-13
PCN13021	51940-084	DESIGN CHANGE	26-Jul-13
PCN13021	51940-084LF	DESIGN CHANGE	26-Jul-13
PCN13021	51940-085	DESIGN CHANGE	26-Jul-13
PCN13021	51940-086	DESIGN CHANGE	26-Jul-13
PCN13021	51940-087	DESIGN CHANGE	26-Jul-13
PCN13021	51940-089	DESIGN CHANGE	26-Jul-13
PCN13021	51940-089LF	DESIGN CHANGE	26-Jul-13
PCN13021	51940-090	DESIGN CHANGE	26-Jul-13
PCN13021	51940-090LF	DESIGN CHANGE	26-Jul-13
PCN13021	51940-091	DESIGN CHANGE	26-Jul-13
PCN13021	51940-092	DESIGN CHANGE	26-Jul-13
PCN13021	51940-094	DESIGN CHANGE	26-Jul-13
PCN13021	51940-094LF	DESIGN CHANGE	26-Jul-13
PCN13021	51940-095	DESIGN CHANGE	26-Jul-13
PCN13021	51940-096	DESIGN CHANGE	26-Jul-13
PCN13021	51940-096LF	DESIGN CHANGE	26-Jul-13
PCN13021	51940-098	DESIGN CHANGE	26-Jul-13
PCN13021	51940-100	DESIGN CHANGE	26-Jul-13
PCN13021	51940-101	DESIGN CHANGE	26-Jul-13
PCN13021	51940-101LF	DESIGN CHANGE	26-Jul-13
PCN13021	51940-102	DESIGN CHANGE	26-Jul-13
PCN13021	51940-103	DESIGN CHANGE	26-Jul-13
PCN13021	51940-103LF	DESIGN CHANGE	26-Jul-13
PCN13021	51940-104	DESIGN CHANGE	26-Jul-13
PCN13021	51940-104LF	DESIGN CHANGE	26-Jul-13
PCN13021	51940-105	DESIGN CHANGE	26-Jul-13
PCN13021	51940-105LF	DESIGN CHANGE	26-Jul-13
PCN13021	51940-106	DESIGN CHANGE	26-Jul-13
PCN13021	51940-107	DESIGN CHANGE	26-Jul-13

PCN13021	51940-107LF	DESIGN CHANGE	26-Jul-13
PCN13021	51940-109	DESIGN CHANGE	26-Jul-13
PCN13021	51940-109LF	DESIGN CHANGE	26-Jul-13
PCN13021	51940-110	DESIGN CHANGE	26-Jul-13
PCN13021	51940-110LF	DESIGN CHANGE	26-Jul-13
PCN13021	51940-111	DESIGN CHANGE	26-Jul-13
PCN13021	51940-112	DESIGN CHANGE	26-Jul-13
PCN13021	51940-112LF	DESIGN CHANGE	26-Jul-13
PCN13021	51940-113	DESIGN CHANGE	26-Jul-13
PCN13021	51940-113LF	DESIGN CHANGE	26-Jul-13
PCN13021	51940-116	DESIGN CHANGE	26-Jul-13
PCN13021	51940-116LF	DESIGN CHANGE	26-Jul-13
PCN13021	51940-117	DESIGN CHANGE	26-Jul-13
PCN13021	51940-117LF	DESIGN CHANGE	26-Jul-13
PCN13021	51940-119	DESIGN CHANGE	26-Jul-13
PCN13021	51940-119LF	DESIGN CHANGE	26-Jul-13
PCN13021	51940-120	DESIGN CHANGE	26-Jul-13
PCN13021	51940-120LF	DESIGN CHANGE	26-Jul-13
PCN13021	51940-121	DESIGN CHANGE	26-Jul-13
PCN13021	51940-121LF	DESIGN CHANGE	26-Jul-13
PCN13021	51940-122	DESIGN CHANGE	26-Jul-13
PCN13021	51940-122LF	DESIGN CHANGE	26-Jul-13
PCN13021	51940-123	DESIGN CHANGE	26-Jul-13
PCN13021	51940-123LF	DESIGN CHANGE	26-Jul-13
PCN13021	51940-124	DESIGN CHANGE	26-Jul-13
PCN13021	51940-125	DESIGN CHANGE	26-Jul-13
PCN13021	51940-125LF	DESIGN CHANGE	26-Jul-13
PCN13021	51940-126LF	DESIGN CHANGE	26-Jul-13
PCN13021	51940-127	DESIGN CHANGE	26-Jul-13
PCN13021	51940-127LF	DESIGN CHANGE	26-Jul-13
PCN13021	51940-130LF	DESIGN CHANGE	26-Jul-13
PCN13021	51940-131LF	DESIGN CHANGE	26-Jul-13
PCN13021	51940-135LF	DESIGN CHANGE	26-Jul-13
PCN13021	51940-136	DESIGN CHANGE	26-Jul-13
PCN13021	51940-136LF	DESIGN CHANGE	26-Jul-13
PCN13021	51940-139	DESIGN CHANGE	26-Jul-13
PCN13021	51940-139LF	DESIGN CHANGE	26-Jul-13
PCN13021	51940-140	DESIGN CHANGE	26-Jul-13
PCN13021	51940-141	DESIGN CHANGE	26-Jul-13
PCN13021	51940-141LF	DESIGN CHANGE	26-Jul-13
PCN13021	51940-142	DESIGN CHANGE	26-Jul-13

PCN13021	51940-142LF	DESIGN CHANGE	26-Jul-13
PCN13021	51940-147	DESIGN CHANGE	26-Jul-13
PCN13021	51940-147LF	DESIGN CHANGE	26-Jul-13
PCN13021	51940-149	DESIGN CHANGE	26-Jul-13
PCN13021	51940-149LF	DESIGN CHANGE	26-Jul-13
PCN13021	51940-151	DESIGN CHANGE	26-Jul-13
PCN13021	51940-151LF	DESIGN CHANGE	26-Jul-13
PCN13021	51940-152	DESIGN CHANGE	26-Jul-13
PCN13021	51940-152LF	DESIGN CHANGE	26-Jul-13
PCN13021	51940-157	DESIGN CHANGE	26-Jul-13
PCN13021	51940-157LF	DESIGN CHANGE	26-Jul-13
PCN13021	51940-160LF	DESIGN CHANGE	26-Jul-13
PCN13021	51940-162LF	DESIGN CHANGE	26-Jul-13
PCN13021	51940-163LF	DESIGN CHANGE	26-Jul-13
PCN13021	51940-164	DESIGN CHANGE	26-Jul-13
PCN13021	51940-164LF	DESIGN CHANGE	26-Jul-13
PCN13021	51940-165LF	DESIGN CHANGE	26-Jul-13
PCN13021	51940-166	DESIGN CHANGE	26-Jul-13
PCN13021	51940-166LF	DESIGN CHANGE	26-Jul-13
PCN13021	51940-168	DESIGN CHANGE	26-Jul-13
PCN13021	51940-168LF	DESIGN CHANGE	26-Jul-13
PCN13021	51940-169	DESIGN CHANGE	26-Jul-13
PCN13021	51940-170	DESIGN CHANGE	26-Jul-13
PCN13021	51940-171	DESIGN CHANGE	26-Jul-13
PCN13021	51940-171LF	DESIGN CHANGE	26-Jul-13
PCN13021	51940-172LF	DESIGN CHANGE	26-Jul-13
PCN13021	51940-173	DESIGN CHANGE	26-Jul-13
PCN13021	51940-173LF	DESIGN CHANGE	26-Jul-13
PCN13021	51940-174	DESIGN CHANGE	26-Jul-13
PCN13021	51940-174LF	DESIGN CHANGE	26-Jul-13
PCN13021	51940-175LF	DESIGN CHANGE	26-Jul-13
PCN13021	51940-178LF	DESIGN CHANGE	26-Jul-13
PCN13021	51940-179	DESIGN CHANGE	26-Jul-13
PCN13021	51940-179LF	DESIGN CHANGE	26-Jul-13
PCN13021	51940-180LF	DESIGN CHANGE	26-Jul-13
PCN13021	51940-181LF	DESIGN CHANGE	26-Jul-13
PCN13021	51940-182	DESIGN CHANGE	26-Jul-13
PCN13021	51940-182LF	DESIGN CHANGE	26-Jul-13
PCN13021	51940-184	DESIGN CHANGE	26-Jul-13
PCN13021	51940-184LF	DESIGN CHANGE	26-Jul-13
PCN13021	51940-185	DESIGN CHANGE	26-Jul-13

PCN13021	51940-185LF	DESIGN CHANGE	26-Jul-13
PCN13021	51940-186LF	DESIGN CHANGE	26-Jul-13
PCN13021	51940-187	DESIGN CHANGE	26-Jul-13
PCN13021	51940-187LF	DESIGN CHANGE	26-Jul-13
PCN13021	51940-188LF	DESIGN CHANGE	26-Jul-13
PCN13021	51940-189	DESIGN CHANGE	26-Jul-13
PCN13021	51940-189LF	DESIGN CHANGE	26-Jul-13
PCN13021	51940-191	DESIGN CHANGE	26-Jul-13
PCN13021	51940-191LF	DESIGN CHANGE	26-Jul-13
PCN13021	51940-193LF	DESIGN CHANGE	26-Jul-13
PCN13021	51940-195LF	DESIGN CHANGE	26-Jul-13
PCN13021	51940-200	DESIGN CHANGE	26-Jul-13
PCN13021	51940-200LF	DESIGN CHANGE	26-Jul-13
PCN13021	51940-203	DESIGN CHANGE	26-Jul-13
PCN13021	51940-203LF	DESIGN CHANGE	26-Jul-13
PCN13021	51940-204	DESIGN CHANGE	26-Jul-13
PCN13021	51940-204LF	DESIGN CHANGE	26-Jul-13
PCN13021	51940-205LF	DESIGN CHANGE	26-Jul-13
PCN13021	51940-206LF	DESIGN CHANGE	26-Jul-13
PCN13021	51940-207LF	DESIGN CHANGE	26-Jul-13
PCN13021	51940-208LF	DESIGN CHANGE	26-Jul-13
PCN13021	51940-209LF	DESIGN CHANGE	26-Jul-13
PCN13021	51940-211	DESIGN CHANGE	26-Jul-13
PCN13021	51940-211LF	DESIGN CHANGE	26-Jul-13
PCN13021	51940-212	DESIGN CHANGE	26-Jul-13
PCN13021	51940-212LF	DESIGN CHANGE	26-Jul-13
PCN13021	51940-213	DESIGN CHANGE	26-Jul-13
PCN13021	51940-213LF	DESIGN CHANGE	26-Jul-13
PCN13021	51940-214LF	DESIGN CHANGE	26-Jul-13
PCN13021	51940-216	DESIGN CHANGE	26-Jul-13
PCN13021	51940-216LF	DESIGN CHANGE	26-Jul-13
PCN13021	51940-217LF	DESIGN CHANGE	26-Jul-13
PCN13021	51940-218LF	DESIGN CHANGE	26-Jul-13
PCN13021	51940-219LF	DESIGN CHANGE	26-Jul-13
PCN13021	51940-220LF	DESIGN CHANGE	26-Jul-13
PCN13021	51940-221LF	DESIGN CHANGE	26-Jul-13
PCN13021	51940-222LF	DESIGN CHANGE	26-Jul-13
PCN13021	51940-224LF	DESIGN CHANGE	26-Jul-13
PCN13021	51940-226LF	DESIGN CHANGE	26-Jul-13
PCN13021	51940-228LF	DESIGN CHANGE	26-Jul-13
PCN13021	51940-230LF	DESIGN CHANGE	26-Jul-13

PCN13021	51940-231LF	DESIGN CHANGE	26-Jul-13
PCN13021	51940-233LF	DESIGN CHANGE	26-Jul-13
PCN13021	51940-234LF	DESIGN CHANGE	26-Jul-13
PCN13021	51940-235LF	DESIGN CHANGE	26-Jul-13
PCN13021	51940-236LF	DESIGN CHANGE	26-Jul-13
PCN13021	51940-237LF	DESIGN CHANGE	26-Jul-13
PCN13021	51940-238LF	DESIGN CHANGE	26-Jul-13
PCN13021	51940-241LF	DESIGN CHANGE	26-Jul-13
PCN13021	51940-243LF	DESIGN CHANGE	26-Jul-13
PCN13021	51940-248LF	DESIGN CHANGE	26-Jul-13
PCN13021	51940-249	DESIGN CHANGE	26-Jul-13
PCN13021	51940-249LF	DESIGN CHANGE	26-Jul-13
PCN13021	51940-251LF	DESIGN CHANGE	26-Jul-13
PCN13021	51940-252LF	DESIGN CHANGE	26-Jul-13
PCN13021	51940-253LF	DESIGN CHANGE	26-Jul-13
PCN13021	51940-255LF	DESIGN CHANGE	26-Jul-13
PCN13021	51940-257LF	DESIGN CHANGE	26-Jul-13
PCN13021	51940-258LF	DESIGN CHANGE	26-Jul-13
PCN13021	51940-259LF	DESIGN CHANGE	26-Jul-13
PCN13021	51940-260LF	DESIGN CHANGE	26-Jul-13
PCN13021	51940-263LF	DESIGN CHANGE	26-Jul-13
PCN13021	51940-265LF	DESIGN CHANGE	26-Jul-13
PCN13021	51940-269LF	DESIGN CHANGE	26-Jul-13
PCN13021	51940-270LF	DESIGN CHANGE	26-Jul-13
PCN13021	51940-271LF	DESIGN CHANGE	26-Jul-13
PCN13021	51940-272LF	DESIGN CHANGE	26-Jul-13
PCN13021	51940-276LF	DESIGN CHANGE	26-Jul-13
PCN13021	51940-277LF	DESIGN CHANGE	26-Jul-13
PCN13021	51940-278LF	DESIGN CHANGE	26-Jul-13
PCN13021	51940-279LF	DESIGN CHANGE	26-Jul-13
PCN13021	51940-280LF	DESIGN CHANGE	26-Jul-13
PCN13021	51940-281LF	DESIGN CHANGE	26-Jul-13
PCN13021	51940-282LF	DESIGN CHANGE	26-Jul-13
PCN13021	51940-283LF	DESIGN CHANGE	26-Jul-13
PCN13021	51940-286LF	DESIGN CHANGE	26-Jul-13
PCN13021	51940-287LF	DESIGN CHANGE	26-Jul-13
PCN13021	51940-288LF	DESIGN CHANGE	26-Jul-13
PCN13021	51940-289LF	DESIGN CHANGE	26-Jul-13
PCN13021	51940-290LF	DESIGN CHANGE	26-Jul-13
PCN13021	51940-293LF	DESIGN CHANGE	26-Jul-13
PCN13021	51940-295LF	DESIGN CHANGE	26-Jul-13



PCN13021	51940-296LF	DESIGN CHANGE	26-Jul-13
PCN13021	51940-297LF	DESIGN CHANGE	26-Jul-13
PCN13021	51940-298LF	DESIGN CHANGE	26-Jul-13
PCN13021	51940-301LF	DESIGN CHANGE	26-Jul-13
PCN13021	51940-302LF	DESIGN CHANGE	26-Jul-13
PCN13021	51940-305LF	DESIGN CHANGE	26-Jul-13
PCN13021	51940-306LF	DESIGN CHANGE	26-Jul-13
PCN13021	51940-307LF	DESIGN CHANGE	26-Jul-13
PCN13021	51940-311LF	DESIGN CHANGE	26-Jul-13
PCN13021	51940-312LF	DESIGN CHANGE	26-Jul-13
PCN13021	51940-313LF	DESIGN CHANGE	26-Jul-13
PCN13021	51940-319LF	DESIGN CHANGE	26-Jul-13
PCN13021	51940-320LF	DESIGN CHANGE	26-Jul-13
PCN13021	51940-323LF	DESIGN CHANGE	26-Jul-13
PCN13021	51940-324LF	DESIGN CHANGE	26-Jul-13
PCN13021	51940-327LF	DESIGN CHANGE	26-Jul-13
PCN13021	51940-329LF	DESIGN CHANGE	26-Jul-13
PCN13021	51940-330LF	DESIGN CHANGE	26-Jul-13
PCN13021	51940-331LF	DESIGN CHANGE	26-Jul-13
PCN13021	51940-332LF	DESIGN CHANGE	26-Jul-13
PCN13021	51940-335LF	DESIGN CHANGE	26-Jul-13
PCN13021	51940-336LF	DESIGN CHANGE	26-Jul-13
PCN13021	51940-337LF	DESIGN CHANGE	26-Jul-13
PCN13021	51940-338LF	DESIGN CHANGE	26-Jul-13
PCN13021	51940-342LF	DESIGN CHANGE	26-Jul-13
PCN13021	51940-343LF	DESIGN CHANGE	26-Jul-13
PCN13021	51940-346LF	DESIGN CHANGE	26-Jul-13
PCN13021	51940-347LF	DESIGN CHANGE	26-Jul-13
PCN13021	51940-348LF	DESIGN CHANGE	26-Jul-13
PCN13021	51940-350LF	DESIGN CHANGE	26-Jul-13
PCN13021	51940-351LF	DESIGN CHANGE	26-Jul-13
PCN13021	51940-355LF	DESIGN CHANGE	26-Jul-13
PCN13021	51940-361LF	DESIGN CHANGE	26-Jul-13
PCN13021	51940-362LF	DESIGN CHANGE	26-Jul-13
PCN13021	51940-364LF	DESIGN CHANGE	26-Jul-13
PCN13021	51940-367LF	DESIGN CHANGE	26-Jul-13
PCN13021	51940-370LF	DESIGN CHANGE	26-Jul-13
PCN13021	51940-371LF	DESIGN CHANGE	26-Jul-13
PCN13021	51940-373LF	DESIGN CHANGE	26-Jul-13
PCN13021	51940-374LF	DESIGN CHANGE	26-Jul-13
PCN13021	51940-378LF	DESIGN CHANGE	26-Jul-13

PCN13021	51940-382LF	DESIGN CHANGE	26-Jul-13
PCN13021	51940-383LF	DESIGN CHANGE	26-Jul-13
PCN13021	51940-384LF	DESIGN CHANGE	26-Jul-13
PCN13021	51940-385LF	DESIGN CHANGE	26-Jul-13
PCN13021	51940-386LF	DESIGN CHANGE	26-Jul-13
PCN13021	51940-388LF	DESIGN CHANGE	26-Jul-13
PCN13021	51940-389LF	DESIGN CHANGE	26-Jul-13
PCN13021	51940-390LF	DESIGN CHANGE	26-Jul-13
PCN13021	51940-391LF	DESIGN CHANGE	26-Jul-13
PCN13021	51940-392LF	DESIGN CHANGE	26-Jul-13
PCN13021	51940-394LF	DESIGN CHANGE	26-Jul-13
PCN13021	51940-396LF	DESIGN CHANGE	26-Jul-13
PCN13021	51940-397LF	DESIGN CHANGE	26-Jul-13
PCN13021	51940-401LF	DESIGN CHANGE	26-Jul-13
PCN13021	51940-402LF	DESIGN CHANGE	26-Jul-13
PCN13021	51940-403LF	DESIGN CHANGE	26-Jul-13
PCN13021	51940-406LF	DESIGN CHANGE	26-Jul-13
PCN13021	51940-407LF	DESIGN CHANGE	26-Jul-13
PCN13021	51940-408LF	DESIGN CHANGE	26-Jul-13
PCN13021	51940-411LF	DESIGN CHANGE	26-Jul-13
PCN13021	51940-416LF	DESIGN CHANGE	26-Jul-13
PCN13021	51940-418LF	DESIGN CHANGE	26-Jul-13
PCN13021	51940-419LF	DESIGN CHANGE	26-Jul-13
PCN13021	51940-420LF	DESIGN CHANGE	26-Jul-13
PCN13021	51940-423LF	DESIGN CHANGE	26-Jul-13
PCN13021	51940-425LF	DESIGN CHANGE	26-Jul-13
PCN13021	51940-428LF	DESIGN CHANGE	26-Jul-13
PCN13021	51940-429LF	DESIGN CHANGE	26-Jul-13
PCN13021	51940-430LF	DESIGN CHANGE	26-Jul-13
PCN13021	51940-431LF	DESIGN CHANGE	26-Jul-13
PCN13021	51940-432LF	DESIGN CHANGE	26-Jul-13
PCN13021	51940-433LF	DESIGN CHANGE	26-Jul-13
PCN13021	51940-436LF	DESIGN CHANGE	26-Jul-13
PCN13021	51940-437LF	DESIGN CHANGE	26-Jul-13
PCN13021	51940-438LF	DESIGN CHANGE	26-Jul-13
PCN13021	51940-439LF	DESIGN CHANGE	26-Jul-13
PCN13021	51940-440LF	DESIGN CHANGE	26-Jul-13
PCN13021	51940-441LF	DESIGN CHANGE	26-Jul-13
PCN13021	51940-442LF	DESIGN CHANGE	26-Jul-13
PCN13021	51940-445LF	DESIGN CHANGE	26-Jul-13
PCN13021	51940-446LF	DESIGN CHANGE	26-Jul-13

PCN13021	51940-447LF	DESIGN CHANGE	26-Jul-13
PCN13021	51940-454LF	DESIGN CHANGE	26-Jul-13
PCN13021	51940-456LF	DESIGN CHANGE	26-Jul-13
PCN13021	51940-457LF	DESIGN CHANGE	26-Jul-13
PCN13021	51940-459LF	DESIGN CHANGE	26-Jul-13
PCN13021	51940-461LF	DESIGN CHANGE	26-Jul-13
PCN13021	51940-464LF	DESIGN CHANGE	26-Jul-13
PCN13021	51940-466LF	DESIGN CHANGE	26-Jul-13
PCN13021	51940-471LF	DESIGN CHANGE	26-Jul-13
PCN13021	51940-473LF	DESIGN CHANGE	26-Jul-13
PCN13021	51940-474LF	DESIGN CHANGE	26-Jul-13
PCN13021	51940-475LF	DESIGN CHANGE	26-Jul-13
PCN13021	51951-001	DESIGN CHANGE	26-Jul-13
PCN13021	51952-001	DESIGN CHANGE	26-Jul-13
PCN13021	51952-001LF	DESIGN CHANGE	26-Jul-13
PCN13021	51952-002	DESIGN CHANGE	26-Jul-13
PCN13021	51952-002LF	DESIGN CHANGE	26-Jul-13
PCN13021	51952-003	DESIGN CHANGE	26-Jul-13
PCN13021	51952-005	DESIGN CHANGE	26-Jul-13
PCN13021	51952-006	DESIGN CHANGE	26-Jul-13
PCN13021	51952-008	DESIGN CHANGE	26-Jul-13
PCN13021	51952-009	DESIGN CHANGE	26-Jul-13
PCN13021	51952-010	DESIGN CHANGE	26-Jul-13
PCN13021	51952-010LF	DESIGN CHANGE	26-Jul-13
PCN13021	51952-011	DESIGN CHANGE	26-Jul-13
PCN13021	51952-012	DESIGN CHANGE	26-Jul-13
PCN13021	51952-013	DESIGN CHANGE	26-Jul-13
PCN13021	51952-013LF	DESIGN CHANGE	26-Jul-13
PCN13021	51952-015	DESIGN CHANGE	26-Jul-13
PCN13021	51952-015LF	DESIGN CHANGE	26-Jul-13
PCN13021	51952-016	DESIGN CHANGE	26-Jul-13
PCN13021	51952-017	DESIGN CHANGE	26-Jul-13
PCN13021	51952-018	DESIGN CHANGE	26-Jul-13
PCN13021	51952-019	DESIGN CHANGE	26-Jul-13
PCN13021	51952-019LF	DESIGN CHANGE	26-Jul-13
PCN13021	51952-020	DESIGN CHANGE	26-Jul-13
PCN13021	51952-021	DESIGN CHANGE	26-Jul-13
PCN13021	51952-022	DESIGN CHANGE	26-Jul-13
PCN13021	51952-023	DESIGN CHANGE	26-Jul-13
PCN13021	51952-024	DESIGN CHANGE	26-Jul-13
PCN13021	51952-027	DESIGN CHANGE	26-Jul-13

PCN13021	51952-028	DESIGN CHANGE	26-Jul-13
PCN13021	51952-029	DESIGN CHANGE	26-Jul-13
PCN13021	51952-030	DESIGN CHANGE	26-Jul-13
PCN13021	51952-031	DESIGN CHANGE	26-Jul-13
PCN13021	51952-031LF	DESIGN CHANGE	26-Jul-13
PCN13021	51952-033	DESIGN CHANGE	26-Jul-13
PCN13021	51952-033LF	DESIGN CHANGE	26-Jul-13
PCN13021	51952-034	DESIGN CHANGE	26-Jul-13
PCN13021	51952-035	DESIGN CHANGE	26-Jul-13
PCN13021	51952-037	DESIGN CHANGE	26-Jul-13
PCN13021	51952-037LF	DESIGN CHANGE	26-Jul-13
PCN13021	51952-039	DESIGN CHANGE	26-Jul-13
PCN13021	51952-039LF	DESIGN CHANGE	26-Jul-13
PCN13021	51952-040	DESIGN CHANGE	26-Jul-13
PCN13021	51952-040LF	DESIGN CHANGE	26-Jul-13
PCN13021	51952-041	DESIGN CHANGE	26-Jul-13
PCN13021	51952-041LF	DESIGN CHANGE	26-Jul-13
PCN13021	51952-042	DESIGN CHANGE	26-Jul-13
PCN13021	51952-043	DESIGN CHANGE	26-Jul-13
PCN13021	51952-045	DESIGN CHANGE	26-Jul-13
PCN13021	51952-046	DESIGN CHANGE	26-Jul-13
PCN13021	51952-047	DESIGN CHANGE	26-Jul-13
PCN13021	51952-047GLF	DESIGN CHANGE	26-Jul-13
PCN13021	51952-047LF	DESIGN CHANGE	26-Jul-13
PCN13021	51952-048	DESIGN CHANGE	26-Jul-13
PCN13021	51952-049	DESIGN CHANGE	26-Jul-13
PCN13021	51952-051	DESIGN CHANGE	26-Jul-13
PCN13021	51952-051LF	DESIGN CHANGE	26-Jul-13
PCN13021	51952-053	DESIGN CHANGE	26-Jul-13
PCN13021	51952-053LF	DESIGN CHANGE	26-Jul-13
PCN13021	51952-054	DESIGN CHANGE	26-Jul-13
PCN13021	51952-055	DESIGN CHANGE	26-Jul-13
PCN13021	51952-055LF	DESIGN CHANGE	26-Jul-13
PCN13021	51952-056	DESIGN CHANGE	26-Jul-13
PCN13021	51952-056LF	DESIGN CHANGE	26-Jul-13
PCN13021	51952-057	DESIGN CHANGE	26-Jul-13
PCN13021	51952-058	DESIGN CHANGE	26-Jul-13
PCN13021	51952-058LF	DESIGN CHANGE	26-Jul-13
PCN13021	51952-059	DESIGN CHANGE	26-Jul-13
PCN13021	51952-059LF	DESIGN CHANGE	26-Jul-13
PCN13021	51952-060	DESIGN CHANGE	26-Jul-13

PCN13021	51952-060LF	DESIGN CHANGE	26-Jul-13
PCN13021	51952-061LF	DESIGN CHANGE	26-Jul-13
PCN13021	51952-062LF	DESIGN CHANGE	26-Jul-13
PCN13021	51952-063	DESIGN CHANGE	26-Jul-13
PCN13021	51952-063LF	DESIGN CHANGE	26-Jul-13
PCN13021	51952-073LF	DESIGN CHANGE	26-Jul-13
PCN13021	51952-074LF	DESIGN CHANGE	26-Jul-13
PCN13021	51952-076LF	DESIGN CHANGE	26-Jul-13
PCN13021	51952-077	DESIGN CHANGE	26-Jul-13
PCN13021	51952-077LF	DESIGN CHANGE	26-Jul-13
PCN13021	51952-078LF	DESIGN CHANGE	26-Jul-13
PCN13021	51952-079LF	DESIGN CHANGE	26-Jul-13
PCN13021	51952-081	DESIGN CHANGE	26-Jul-13
PCN13021	51952-081LF	DESIGN CHANGE	26-Jul-13
PCN13021	51952-087	DESIGN CHANGE	26-Jul-13
PCN13021	51952-087LF	DESIGN CHANGE	26-Jul-13
PCN13021	51952-088LF	DESIGN CHANGE	26-Jul-13
PCN13021	51952-090	DESIGN CHANGE	26-Jul-13
PCN13021	51952-091LF	DESIGN CHANGE	26-Jul-13
PCN13021	51952-093	DESIGN CHANGE	26-Jul-13
PCN13021	51952-093LF	DESIGN CHANGE	26-Jul-13
PCN13021	51952-094LF	DESIGN CHANGE	26-Jul-13
PCN13021	51952-095	DESIGN CHANGE	26-Jul-13
PCN13021	51952-095LF	DESIGN CHANGE	26-Jul-13
PCN13021	51952-099	DESIGN CHANGE	26-Jul-13
PCN13021	51952-099LF	DESIGN CHANGE	26-Jul-13
PCN13021	51952-104	DESIGN CHANGE	26-Jul-13
PCN13021	51952-104LF	DESIGN CHANGE	26-Jul-13
PCN13021	51952-105LF	DESIGN CHANGE	26-Jul-13
PCN13021	51952-106LF	DESIGN CHANGE	26-Jul-13
PCN13021	51952-107LF	DESIGN CHANGE	26-Jul-13
PCN13021	51952-109LF	DESIGN CHANGE	26-Jul-13
PCN13021	51952-110	DESIGN CHANGE	26-Jul-13
PCN13021	51952-110LF	DESIGN CHANGE	26-Jul-13
PCN13021	51952-111LF	DESIGN CHANGE	26-Jul-13
PCN13021	51952-115LF	DESIGN CHANGE	26-Jul-13
PCN13021	51952-116LF	DESIGN CHANGE	26-Jul-13
PCN13021	51952-119LF	DESIGN CHANGE	26-Jul-13
PCN13021	51952-120LF	DESIGN CHANGE	26-Jul-13
PCN13021	51952-123LF	DESIGN CHANGE	26-Jul-13
PCN13021	51952-125LF	DESIGN CHANGE	26-Jul-13

PCN13021	51952-127LF	DESIGN CHANGE	26-Jul-13
PCN13021	51952-135LF	DESIGN CHANGE	26-Jul-13
PCN13021	51952-138LF	DESIGN CHANGE	26-Jul-13
PCN13021	51952-142LF	DESIGN CHANGE	26-Jul-13
PCN13021	51952-143LF	DESIGN CHANGE	26-Jul-13
PCN13021	51952-146LF	DESIGN CHANGE	26-Jul-13
PCN13021	51952-147LF	DESIGN CHANGE	26-Jul-13
PCN13021	51952-152LF	DESIGN CHANGE	26-Jul-13
PCN13021	51952-155LF	DESIGN CHANGE	26-Jul-13
PCN13021	51952-158LF	DESIGN CHANGE	26-Jul-13
PCN13021	51952-159LF	DESIGN CHANGE	26-Jul-13
PCN13021	51952-163LF	DESIGN CHANGE	26-Jul-13
PCN13021	51952-164LF	DESIGN CHANGE	26-Jul-13
PCN13021	51952-166LF	DESIGN CHANGE	26-Jul-13
PCN13021	51952-170LF	DESIGN CHANGE	26-Jul-13
PCN13021	51952-175LF	DESIGN CHANGE	26-Jul-13
PCN13021	51952-179LF	DESIGN CHANGE	26-Jul-13
PCN13021	51952-182LF	DESIGN CHANGE	26-Jul-13
PCN13021	51952-184LF	DESIGN CHANGE	26-Jul-13
PCN13021	51952-185LF	DESIGN CHANGE	26-Jul-13
PCN13021	51952-186LF	DESIGN CHANGE	26-Jul-13
PCN13021	51952-188LF	DESIGN CHANGE	26-Jul-13
PCN13021	51952-189LF	DESIGN CHANGE	26-Jul-13
PCN13021	51952-192LF	DESIGN CHANGE	26-Jul-13
PCN13021	51952-194LF	DESIGN CHANGE	26-Jul-13
PCN13021	51952-195LF	DESIGN CHANGE	26-Jul-13
PCN13021	51952-199LF	DESIGN CHANGE	26-Jul-13
PCN13021	51952-202LF	DESIGN CHANGE	26-Jul-13
PCN13021	51952-204LF	DESIGN CHANGE	26-Jul-13
PCN13021	51952-206LF	DESIGN CHANGE	26-Jul-13
PCN13021	51952-208LF	DESIGN CHANGE	26-Jul-13
PCN13021	51952-211LF	DESIGN CHANGE	26-Jul-13
PCN13021	51952-212LF	DESIGN CHANGE	26-Jul-13
PCN13021	51952-213LF	DESIGN CHANGE	26-Jul-13
PCN13021	51952-216LF	DESIGN CHANGE	26-Jul-13
PCN13021	51952-217LF	DESIGN CHANGE	26-Jul-13
PCN13021	51952-220LF	DESIGN CHANGE	26-Jul-13
PCN13021	51952-221LF	DESIGN CHANGE	26-Jul-13
PCN13021	51952-222LF	DESIGN CHANGE	26-Jul-13
PCN13021	51952-224LF	DESIGN CHANGE	26-Jul-13
PCN13021	51952-228LF	DESIGN CHANGE	26-Jul-13

PCN13021	51952-229LF	DESIGN CHANGE	26-Jul-13
PCN13021	51952-230LF	DESIGN CHANGE	26-Jul-13
PCN13021	51952-232LF	DESIGN CHANGE	26-Jul-13
PCN13021	51952-236LF	DESIGN CHANGE	26-Jul-13
PCN13021	51952-238LF	DESIGN CHANGE	26-Jul-13
PCN13021	51952-288LF	DESIGN CHANGE	26-Jul-13
PCN13021	51955-001	DESIGN CHANGE	26-Jul-13
PCN13021	51955-001LF	DESIGN CHANGE	26-Jul-13
PCN13021	51955-002H	DESIGN CHANGE	26-Jul-13
PCN13021	51963-002LF	DESIGN CHANGE	26-Jul-13
PCN13021	51963-005	DESIGN CHANGE	26-Jul-13
PCN13021	51963-005LF	DESIGN CHANGE	26-Jul-13
PCN13021	51963-006	DESIGN CHANGE	26-Jul-13
PCN13021	51963-007	DESIGN CHANGE	26-Jul-13
PCN13021	51963-007LF	DESIGN CHANGE	26-Jul-13
PCN13021	51963-009	DESIGN CHANGE	26-Jul-13
PCN13021	51963-009LF	DESIGN CHANGE	26-Jul-13
PCN13021	51963-010	DESIGN CHANGE	26-Jul-13
PCN13021	51963-011	DESIGN CHANGE	26-Jul-13
PCN13021	51963-011LF	DESIGN CHANGE	26-Jul-13
PCN13021	51963-022LF	DESIGN CHANGE	26-Jul-13
PCN13021	51963-026LF	DESIGN CHANGE	26-Jul-13
PCN13021	51963-031	DESIGN CHANGE	26-Jul-13
PCN13021	51963-031LF	DESIGN CHANGE	26-Jul-13
PCN13021	51963-035LF	DESIGN CHANGE	26-Jul-13
PCN13021	51963-040LF	DESIGN CHANGE	26-Jul-13
PCN13021	51963-041LF	DESIGN CHANGE	26-Jul-13
PCN13021	51963-043LF	DESIGN CHANGE	26-Jul-13
PCN13021	51963-048LF	DESIGN CHANGE	26-Jul-13
PCN13021	51963-049LF	DESIGN CHANGE	26-Jul-13
PCN13021	51963-050LF	DESIGN CHANGE	26-Jul-13
PCN13021	51963-052LF	DESIGN CHANGE	26-Jul-13
PCN13021	51963-054LF	DESIGN CHANGE	26-Jul-13
PCN13021	51963-056LF	DESIGN CHANGE	26-Jul-13
PCN13021	51963-058LF	DESIGN CHANGE	26-Jul-13
PCN13021	51963-059LF	DESIGN CHANGE	26-Jul-13
PCN13021	51963-061LF	DESIGN CHANGE	26-Jul-13
PCN13021	51963-062LF	DESIGN CHANGE	26-Jul-13
PCN13021	51963-065LF	DESIGN CHANGE	26-Jul-13
PCN13021	51963-069LF	DESIGN CHANGE	26-Jul-13
PCN13021	51963-072LF	DESIGN CHANGE	26-Jul-13

PCN13021	51963-075LF	DESIGN CHANGE	26-Jul-13
PCN13021	51965-10000800AALF	DESIGN CHANGE	26-Jul-13
PCN13021	51965-10001600AALF	DESIGN CHANGE	26-Jul-13
PCN13021	51965-10001600CALF	DESIGN CHANGE	26-Jul-13
PCN13021	51965-10002000AALF	DESIGN CHANGE	26-Jul-13
PCN13021	51965-10002000CCLF	DESIGN CHANGE	26-Jul-13
PCN13021	51965-10002400ACLF	DESIGN CHANGE	26-Jul-13
PCN13021	51965-10002400CCLF	DESIGN CHANGE	26-Jul-13
PCN13021	51965-10002800AALF	DESIGN CHANGE	26-Jul-13
PCN13021	51965-10003200AALF	DESIGN CHANGE	26-Jul-13
PCN13021	51965-10003200CA	DESIGN CHANGE	26-Jul-13
PCN13021	51965-10003200CCLF	DESIGN CHANGE	26-Jul-13
PCN13021	51965-10004800AALF	DESIGN CHANGE	26-Jul-13
PCN13021	51965-10004800CCLF	DESIGN CHANGE	26-Jul-13
PCN13021	51965-10010000CCLF	DESIGN CHANGE	26-Jul-13
PCN13021	51965-10012800ACLF	DESIGN CHANGE	26-Jul-13
PCN13021	51966-10000800ABLF	DESIGN CHANGE	26-Jul-13
PCN13021	51966-10001200AALF	DESIGN CHANGE	26-Jul-13
PCN13021	51966-10001600AALF	DESIGN CHANGE	26-Jul-13
PCN13021	51966-10001600ABLF	DESIGN CHANGE	26-Jul-13
PCN13021	51966-10002000AALF	DESIGN CHANGE	26-Jul-13
PCN13021	51966-10002400AALF	DESIGN CHANGE	26-Jul-13
PCN13021	51966-10003200AALF	DESIGN CHANGE	26-Jul-13
PCN13021	51966-10003200ABLF	DESIGN CHANGE	26-Jul-13
PCN13021	51966-10003600AALF	DESIGN CHANGE	26-Jul-13
PCN13021	51966-10004000AALF	DESIGN CHANGE	26-Jul-13
PCN13021	51966-10004000ABLF	DESIGN CHANGE	26-Jul-13
PCN13021	51966-10004400AALF	DESIGN CHANGE	26-Jul-13
PCN13021	51966-10004800ABLF	DESIGN CHANGE	26-Jul-13
PCN13021	51966-10005200AALF	DESIGN CHANGE	26-Jul-13
PCN13021	51966-10005200ABLF	DESIGN CHANGE	26-Jul-13
PCN13021	51966-10006400AALF	DESIGN CHANGE	26-Jul-13
PCN13021	51966-10006800ABLF	DESIGN CHANGE	26-Jul-13
PCN13021	51966-10007200ABLF	DESIGN CHANGE	26-Jul-13
PCN13021	51966-10007600AALF	DESIGN CHANGE	26-Jul-13
PCN13021	51966-10009200ABLF	DESIGN CHANGE	26-Jul-13
PCN13021	51966-10009600ABLF	DESIGN CHANGE	26-Jul-13
PCN13021	51966-10010000AALF	DESIGN CHANGE	26-Jul-13
PCN13021	51966-10012000AALF	DESIGN CHANGE	26-Jul-13
PCN13021	51966-10012800AALF	DESIGN CHANGE	26-Jul-13
PCN13021	51966-10014400ABLF	DESIGN CHANGE	26-Jul-13



PCN13021	51966-10014800AA	DESIGN CHANGE	26-Jul-13
PCN13021	51966-10014800AALF	DESIGN CHANGE	26-Jul-13
PCN13021	51967-10000800AALF	DESIGN CHANGE	26-Jul-13
PCN13021	51967-10001200CCLF	DESIGN CHANGE	26-Jul-13
PCN13021	51967-10001600AALF	DESIGN CHANGE	26-Jul-13
PCN13021	51967-10001600CCLF	DESIGN CHANGE	26-Jul-13
PCN13021	51967-10002000CCLF	DESIGN CHANGE	26-Jul-13
PCN13021	51967-10002400ACLF	DESIGN CHANGE	26-Jul-13
PCN13021	51967-10002400CCLF	DESIGN CHANGE	26-Jul-13
PCN13021	51967-10002800AALF	DESIGN CHANGE	26-Jul-13
PCN13021	51967-10003200AALF	DESIGN CHANGE	26-Jul-13
PCN13021	51967-10003200CCLF	DESIGN CHANGE	26-Jul-13
PCN13021	51967-10004000AALF	DESIGN CHANGE	26-Jul-13
PCN13021	51967-10004800AALF	DESIGN CHANGE	26-Jul-13
PCN13021	51967-10005200AALF	DESIGN CHANGE	26-Jul-13
PCN13021	51967-10005200CCLF	DESIGN CHANGE	26-Jul-13
PCN13021	51967-10007200CCLF	DESIGN CHANGE	26-Jul-13
PCN13021	51967-10009600ACLF	DESIGN CHANGE	26-Jul-13
PCN13021	51967-10010000CCLF	DESIGN CHANGE	26-Jul-13
PCN13021	51967-10012000AALF	DESIGN CHANGE	26-Jul-13
PCN13021	51967-10012800ACLF	DESIGN CHANGE	26-Jul-13
PCN13021	51967-10014400AALF	DESIGN CHANGE	26-Jul-13
PCN13021	51967-10014800AA	DESIGN CHANGE	26-Jul-13
PCN13021	51967-10014800AALF	DESIGN CHANGE	26-Jul-13
PCN13021	51968-10000800AALF	DESIGN CHANGE	26-Jul-13
PCN13021	51968-10001600AALF	DESIGN CHANGE	26-Jul-13
PCN13021	51968-10002000AALF	DESIGN CHANGE	26-Jul-13
PCN13021	51968-10002400AALF	DESIGN CHANGE	26-Jul-13
PCN13021	51968-10002400ABLF	DESIGN CHANGE	26-Jul-13
PCN13021	51968-10002400CBLF	DESIGN CHANGE	26-Jul-13
PCN13021	51968-10003200AALF	DESIGN CHANGE	26-Jul-13
PCN13021	51968-10003200ABLF	DESIGN CHANGE	26-Jul-13
PCN13021	51968-10003200CBLF	DESIGN CHANGE	26-Jul-13
PCN13021	51968-10003600AALF	DESIGN CHANGE	26-Jul-13
PCN13021	51968-10004000AALF	DESIGN CHANGE	26-Jul-13
PCN13021	51968-10004400AALF	DESIGN CHANGE	26-Jul-13
PCN13021	51968-10004800ABLF	DESIGN CHANGE	26-Jul-13
PCN13021	51968-10004800CBLF	DESIGN CHANGE	26-Jul-13
PCN13021	51968-10006400AALF	DESIGN CHANGE	26-Jul-13
PCN13021	51968-10006800ABLF	DESIGN CHANGE	26-Jul-13
PCN13021	51968-10007600AALF	DESIGN CHANGE	26-Jul-13

PCN13021	51968-10009200ABLF	DESIGN CHANGE	26-Jul-13
PCN13021	51968-10009600ABLF	DESIGN CHANGE	26-Jul-13
PCN13021	51968-10010000AALF	DESIGN CHANGE	26-Jul-13
PCN13021	51968-10012800AALF	DESIGN CHANGE	26-Jul-13
PCN13021	51968-10014800AALF	DESIGN CHANGE	26-Jul-13
PCN13021	51970-002	DESIGN CHANGE	26-Jul-13
PCN13021	51970-002LF	DESIGN CHANGE	26-Jul-13
PCN13021	51970-003	DESIGN CHANGE	26-Jul-13
PCN13021	51970-004	DESIGN CHANGE	26-Jul-13
PCN13021	51970-004LF	DESIGN CHANGE	26-Jul-13

NUMBER <b>GS-12-149</b>	TYPE <b>PRODUCT SPECIFICATION</b>		
TITLE PwrBlade ® Product Specification		PAGE 1 of 10	REVISION U
		AUTHORIZED BY Jerome Chen	DATE 02 Jun 10
		CLASSIFICATION <b>UNRESTRICTED</b>	

### 1.0 **OBJECTIVE**

This specification defines the performance, test, quality and reliability requirements of the PwrBlade Connector System.

### 2.0 **SCOPE**

This specification is applicable to the termination characteristics of separable right angle and vertical headers when mated to the right angle and vertical receptacles.

### 3.0 **GENERAL**

If there is conflict between the product drawings and specifications, the drawing takes precedence.

This document is composed of the following sections:

<u>Paragraph</u>	<u>Title</u>
1.0	OBJECTIVE
2.0	SCOPE
3.0	GENERAL
4.0	APPLICABLE DOCUMENTS
5.0	REQUIREMENTS
5.1	Qualification
5.2	Material
5.3	Finish
5.4	Design and construction
5.5	Workmanship
6.0	ELECTRICAL CHARACTERISTICS
7.0	MECHANICAL CHARACTERISTICS
8.0	ENVIRONMENTAL CONDITIONS
9.0	QUALITY ASSURANCE PROVISIONS
9.1	Equipment Calibration
9.2	Inspection Conditions
9.3	Sample Quality and Description
9.4	Acceptance
9.5	Qualification Testing
9.6	Re-qualification Testing
10.0	Reference Documents
Table 1	Qualification Testing Matrix

NUMBER <b>GS-12-149</b>	TYPE <b>PRODUCT SPECIFICATION</b>		
TITLE PwrBlade ® Product Specification		PAGE 2 of 10	REVISION U
		AUTHORIZED BY Jerome Chen	DATE 02 Jun 10
		CLASSIFICATION <b>UNRESTRICTED</b>	

#### 4.0 APPLICABLE DOCUMENTS

- 4.1 Specifications
  - 4.1.1 Applicable FCI power blade product drawings
- 4.2 Federal Specifications
  - 4.2.1 MIL-STD-1344A: Test Methods for Electrical Connectors
- 4.3 Other Standards and Specifications
  - 4.3.1 UL 94 V-0: Flammability
  - 4.3.2 EIA 364: Test Procedures for Electrical Connectors, Sockets and Coaxial Contacts
- 4.4 FCI Specifications:
  - 4.4.1 BUS-03-601: Current Rating/30°C Temperature Rise
  - 4.4.2 BUS-03-404: Normal Force Measurement
  - 4.4.3 BUS-12-090: HPC Product Specification
  - 4.4.4 BUS-12-111: HPC Solderless (Press fit) Right Angle Receptacle

#### 5.0 REQUIREMENTS

- 5.1 Qualification

Connectors furnished under this specification shall be capable of meeting the qualification test requirements specified herein.
- 5.2 Material

The material for each component shall be as specified herein or equivalent.

Power Contacts – High Performance Copper Alloy  
Signal Header Contacts – Copper Alloy  
Signal Receptacle Contacts – Copper Alloy  
Receptacle and Plug Housings - Glass Filled HTN (High Temperature Nylon)

NUMBER <b>GS-12-149</b>	TYPE <b>PRODUCT SPECIFICATION</b>		
TITLE PwrBlade ® Product Specification		PAGE 3 of 10	REVISION U
		AUTHORIZED BY Jerome Chen	DATE 02 Jun 10
		CLASSIFICATION <b>UNRESTRICTED</b>	

5.3 Finish

Refer to plating specification 10064183.

5.4 Design and Construction

Connectors shall be of the design, construction and physical dimensions specified on the applicable product drawings.

5.4.1 See drawing numbers 51700, 51720, 51740, 51760 and 51866 for test connector configurations.

5.5 Workmanship includes freedom from blistering, cracks, discoloration, etc.

**ELECTRICAL CHARACTERISTICS**

6.1 Signal tested at Low Level (LLCR) – The low level contact resistance shall not exceed 20 milliohm after environmental exposure when measured in accordance with EIA 364 TP 06. The following details shall apply:

- a. Test Voltage – 20 millivolts DC max open circuit.
- b. Test Current – Not to exceed 100 milliamps.

6.2 Power tested at Specified Current – The contact resistance at a specified current shall not exceed 0.7 milliohm end of life when measured in accordance with EIA 364 TP06. Test Current 30 amperes DC

6.3 Insulation Resistance – the insulation resistance of mated connectors shall not be less than 10,000 megohms for power contacts, and 500 megohms for signal initially and after environmental exposure when measured in accordance with EIA 364 TP21

- a. Test Voltage 500 volts DC
- b. Electrification time – 2 minutes
- c. Points of Measurement – Between adjacent Contacts

6.4 Dielectric Withstanding Voltage – There shall be no evidence of arc-over, insulation breakdown, or excessive leakage current (>1 Milliampere ) when mated connectors are tested in accordance with EIA 364 TP 20. The following details apply:

- a. Test Voltage – 2500 volts DC (power), 1000 volts DC (signal)
- b. Test Duration – 60 seconds.
- c. Test Condition – (760 Torr – sea level).
- d. Points of measurement – Between adjacent Contacts

NUMBER <b>GS-12-149</b>	TYPE <b>PRODUCT SPECIFICATION</b>		
TITLE PwrBlade ® Product Specification		PAGE 4 of 10	REVISION U
		AUTHORIZED BY Jerome Chen	DATE 02 Jun 10
CLASSIFICATION <b>UNRESTRICTED</b>			

6.5 Current Rating – The temperature rise above ambient shall not exceed 30° C at any point in the system when all power contacts are powered with each contact being powered at 30 amperes or only one power contact is powered to 48 amperes. The temperature rise above ambient shall not exceed 30° C at any point in the system when all signal contacts are powered with each contact being powered at 1.0 amperes or only one signal contact is powered at 3.0 amperes. The following details shall apply:

- a. Ambient conditions – Still air at 25 °C
- b. Reference – FCI Test Specification BUS-03-601

## 7.0 MECHANICAL CHARACTERISTICS

7.1 Mating/Unmating Force – The force to mate a receptacle connector and compatible header shall not exceed 25 ounces per power contact and 3.5 ounces per signal contact. The unmating force shall not be less than 8 ounces per power contact and .64 ounces per signal contact. The following details shall apply:

- a. Cross Head Speed – 1 inch per minute
- b. Lubrication – None
- c. Utilize free floating fixtures
- d. Reference EIA 364-13

7.2 Normal Force – The contact normal force shall not be less than 350 grams per beam for the power contacts and 50 grams (nor greater than 120 grams) per beam for the signal contacts when tested in accordance with FCI Test Specification BUS-03-404.

7.3 Contact Retention – Individual power and signal contacts shall withstand an axial retention load of 3 pounds. Individual signal receptacle contacts will withstand an axial load of 6 pounds minimum to seat further into housing.

- a. Rate of 0.5 inches/minute without dislodging from the housing cavity.
- b. Test 30 contacts
- c. As per MIL-STD-1344A, Method 2007.1.

7.4 Individual Pin Insertion/Retention Force - The force required to insert an individual compliant pin into a plated through hole in a printed circuit board at a rate of 0.2 inches/minute shall not exceed 6 pounds for signal receptacle contacts, 21 pounds for signal header pins and 25 pounds per tail for power contacts. The retention force in the axial direction opposite that of insertion shall not be less than 1.5 pounds for signal receptacle contacts, 3 pounds for signal header pins and 5 pounds per tail for power contacts.

NUMBER <b>GS-12-149</b>	TYPE <b>PRODUCT SPECIFICATION</b>		
TITLE PwrBlade ® Product Specification		PAGE 5 of 10	REVISION U
		AUTHORIZED BY Jerome Chen	DATE 02 Jun 10
		CLASSIFICATION <b>UNRESTRICTED</b>	

## 7.5 PCB Hole Deformation Radius

Power Contacts – cross-section parallel to board surface. Photograph and measure the hole deformation (deformation on board material) radius at a point .010” from the surface, and the center of the compliant pin section. Include 10 holes. The average (of 10 holes) hole deformation radius shall be no greater than 0.0015” when measured from the drilled hole. The absolute maximum deformation radius shall not exceed 0.002”.

### Signal Contacts

Signal Receptacle Contacts – Reference FCI BUS-12-111 – HPC Solderless (Press Fit) Right Angle Receptacles

Signal Header Contacts – Same as the requirement for Power Contacts above

7.6 PCB Hole Wall Damage – Cross-section perpendicular to the board surface, and through the compliant section wear track. Photograph and measure the copper thickness remaining between the compliant section and the printed wiring board laminate. Include 10 holes. The minimum average (of 10 holes) copper thickness remaining between the compliant pin and the printed wiring board laminate shall not be less than 0.0003”. In addition there shall be no copper cracks, separations between conductive interfaces, or laminate-to-copper separations.

7.7 Board Lock Retention to Housing- Individual board locks shall withstand an axial load of 3 pounds minimum.

- Rate of 0.5 inches/minute without dislodging from the housing cavity.
- Test 30 board locks

## **ENVIRONMENTAL CONDITIONS**

After exposure to the following environmental conditions in accordance with the specified test procedure and / or details, the product shall show no physical damage and shall meet the applicable electrical and mechanical requirements of paragraphs 6.0 and 7.0 as detailed in Table 1 test sequences. Unless otherwise specified, assemblies shall be mated during exposure.

### 8.1 Thermal Shock – EIA 364 TP 32

- a. Test condition – 36 cycles
- b. Temperature Range - -20 to +80 ° C
- c. Time at Each Temperature – To refer to EIA 364 TP 32 based on product mass
- d. Transfer Time – 5 minutes, maximum

### 8.2 Humidity, Steady State – EIA 364 TP 31, Method II

- a. Relative Humidity – 95%
- b. Temperature +40 ° C
- c. Test Duration – 96 hours

NUMBER <b>GS-12-149</b>	TYPE <b>PRODUCT SPECIFICATION</b>		
TITLE PwrBlade ® Product Specification		PAGE 6 of 10	REVISION U
		AUTHORIZED BY Jerome Chen	DATE 02 Jun 10
		CLASSIFICATION <b>UNRESTRICTED</b>	

8.3 High Temperature Life, EIA 364 TP 17

- a. Test Duration – 21 Days
- b. Temperature 105 ° C
- c. Pre-condition – Perform number of durability cycles specified for product

8.4 Environmental Sequence:

Phase I – Thermal Shock, EIA 364-32

- a. Test Duration – 36 cycles
- b. Temperature Range – Between -20 and +80 ° C
- c. Time at Each Temperature – To refer to EIA 364-32 based on product mass
- d. Transfer Time – 5 minutes, maximum

Phase II – Humidity, EIA 364-31, Method II

- a. Test Duration – 10 days
- b. Relative Humidity – 95%
- c. Temperature – 40 deg C

Phase III – High Temperature Life, EIA 364-17

- a. Test Duration – 21days
- b. Temperature – 105 deg C
- c. Pre-condition – Perform number of durability cycles specified for product

8.5 Industrial Mixed Flowing Gas (IMFG) – EIA 364-65

- a. Class – IIA
- b. Duration – 20 days
- c. Mated
- d. Test contact resistance after 10 and 20 days

8.6 Vibration Sinusoidal – EIA 364 TP 28

- a. Condition – III
- b. Vibration Amplitude – 0.06” DA or ± 15G
- c. Frequency Range – 10 to 2000 to 10 Hz
- d. Sweep Time and Duration – 20 minutes per cycle, 4 hours along each of three orthogonal axes (12 hours total)
- e. Mounting – rigidly mount assemblies
- f. No Discontinuities of greater than 10 nano-seconds

8.7 Mechanical Shock – EIA 364-27

- a. Condition I (50G, 11 millisecond half sine wave)
- b. Shocks – 3 shocks in both directions along each of three orthogonal axes (18 total)
- c. Mounting – rigidly mount assemblies
- d. No discontinuities of greater than 10 nano-seconds



NUMBER <b>GS-12-149</b>	TYPE <b>PRODUCT SPECIFICATION</b>		
TITLE PwrBlade ® Product Specification		PAGE 7 of 10	REVISION U
		AUTHORIZED BY Jerome Chen	DATE 02 Jun 10
		CLASSIFICATION <b>UNRESTRICTED</b>	

8.8 Durability – Standard laboratory procedure as applicable to the specific product

- a. Number of Cycles – 200
- b. Cycling rate – 5 inches per minute

8.9 Solderability – ANSI-J-002, Test Condition A

- a. Steam aging – 4 hours
- b. Pcb termination area was evaluated and meets the requirements of ANSI-J-002.

8.10 Resistance to Solder Heat – EIA 364-56

- a. Test Condition – E
- b. There shall be no evidence of physical or mechanical damage.

8.11 Operating temperature – -20 ° C to 105 ° C

## 9.0 QUALITY ASSURANCE PROVISIONS

9.1 Equipment Calibration

All test equipment and inspection facilities used in the performance of any test shall be maintained in a calibration system in accordance with ISO 9000

9.2 Inspection conditions

Unless otherwise specified, all inspections shall be performed under the following conditions:

- a. Temperature: 25 +/- 5° C
- b. Relative humidity: 30 to 60%
- c. Barometric Pressure: Local ambient

NUMBER <b>GS-12-149</b>	TYPE <b>PRODUCT SPECIFICATION</b>		
TITLE PwrBlade ® Product Specification		PAGE 8 of 10	REVISION U
		AUTHORIZED BY Jerome Chen	DATE 02 Jun 10
CLASSIFICATION <b>UNRESTRICTED</b>			

9.3 Sample Quality and Description

R/A Header P/N 51720, Vertical Receptacle P/N 51740 and R/A Receptacle P/N 51760

P/N For lead free test, use 517*0 - *****LF	Type	1	2	3	4	5	6	7	8	9	10	11	12	13	14
51720-11008410AA__	Ass'y	6	3	O	6	6	3	3	O	6	2	3	3	0	0
51740-11008410AA__	Ass'y	0	3	M	0	0	0	0	M	0	0	0	0	0	0
51740-11008410CC__	Ass'y	3	0	I	3	3	0	3	I	3	0	0	0	9	0
51760-11008410AA__	Ass'y	3	0	T	3	3	3	0	T	3	2	3	3	0	12
SK-44146-002	PCB	0	0	T	0	0	0	0	T	0	0	0	0	0	0
SK-44147-002	PCB	0	0	E	0	0	0	0	E	0	0	0	0	9	0
SK-44148-002	PCB	0	0	D	0	0	0	0	D	0	0	0	0	0	0
SK-44146-012	PCB	6	3		6	0	3	3		6	0	0	0	0	0
SK-44147-012	PCB	3	3		3	0	0	3		3	0	0	0	9	0
SK-44148-012	PCB	3	0		3	0	3	0		3	0	0	0	0	0

Vertical Header P/N 51700, R/A Receptacle Press Fit P/N 51866 and Vertical Receptacle P/N 51740 (mated to 51700 for qualification testing)

P/N For lead free test, use 517*0 - *****LF	Type	1	2	3	4	5	6	7	8	9	11	12	13	14
51546-001021__	contact			O		O			O		O		12	
51700-11008410AA__	Ass'y		3	M		M	3		M	4	M	3		
51700-11008410CC__	Ass'y	3		I	3	I		6	I		4	I		
SK-44145-002 (2 oz)	PCB			T		T			T	2	2	T		
SK-44145-012 (5 oz)	PCB	3	3	E	3	E	3	6	E	2	2	E		1
51866-002__	Ass'y	3	3	D	3	D			D	4		D		
51740-1108410AA__	Ass'y						3	6			4			
SK-44148-002 (2 oz)	PCB									2				
SK-44148-012 (5 oz)	PCB	3	3							2				
SK-44147-002 (2 oz)	PCB										2			
SK-44147-012 (5 oz)	PCB						3	6			2			

NUMBER <b>GS-12-149</b>	TYPE <b>PRODUCT SPECIFICATION</b>		
TITLE PwrBlade ® Product Specification		PAGE 9 of 10	REVISION U
		AUTHORIZED BY Jerome Chen	DATE 02 Jun 10
		CLASSIFICATION <b>UNRESTRICTED</b>	

9.4 Acceptance

9.4.1 Electrical and Mechanical requirements shall be as indicated in Paragraphs 6.0 and 7.0 using test data and appropriate statistical techniques.

9.4.2 Failures attributed to equipment, test setup or operator error shall not disqualify the product.

9.5 Qualification Testing

Qualification testing shall be performed on sample units predicted with equipment and procedures normally used in production. Test sequence is as shown in Table 1.

9.6 Re-qualification Testing

If any of the following conditions occur, the responsible product engineer shall initiate re-qualification testing consisting of the applicable parts of the test matrix, Table 1.

- a. A significant design change is made to the existing product that impacts the product form, fit or function. Examples of significant changes shall include, but not be limited to, changes in the plating material composition or thickness, contact force or contact surface geometry, insulator design, contact base material or contact lubrication requirements.
- b. A significant event occurs during production or end use requiring corrective action to be taken relative to the product design or manufacturing process.
- c. A significant change is made to the manufacturing process that impacts the product form, fit or function.

NUMBER <b>GS-12-149</b>	TYPE <b>PRODUCT SPECIFICATION</b>		
TITLE PwrBlade ® Product Specification		PAGE 10 of 10	REVISION U
		AUTHORIZED BY Jerome Chen	DATE 02 Jun 10
CLASSIFICATION <b>UNRESTRICTED</b>			

**Test Sequence Table 1**

Test	PAR	Test Group													
		1	2	3	4	5	6	7	8	9	10	11	12	13	14
<b>Examination of Product</b>	5.5	<b>Test Sequence</b>													
		1 20	1 12	O M	1 8	1 8	1 3	1 8	O M	1 3	1 3	1 1	1 3	1 13	1 3
<b>Contact Resistance Low Level</b>	6.1	3 6 9 14 17	3 6 10	I T T E D	2 6			2 6	I T T E D					3 6 9	
<b>Contact Resistance At specified current</b>	6.2	4 7 10 15 18	4 7 11		3 7			3 7							
<b>Insulation Resistance</b>	6.3					2 6									
<b>Dielectric Withstanding Voltage</b>	6.4					3 7									
<b>Current Rating</b>	6.5									2					
<b>Mating/Unmating Force</b>	7.1	2 11 13 19	2 8												
<b>Normal Force</b>	7.2						2								
<b>Contact Insertion/ Retention</b>	7.3											2			
<b>Individual Pin Insertion (new pin for each insertion)</b>	7.4													2 5 8	
<b>Individual Pin Retention</b>	7.4													4 7 10	
<b>PCB Hole Deformation Radius</b>	7.5													11	
<b>PCB Hole Wall Damage</b>	7.6													12	
<b>Board Lock Retention</b>	7.7														2
<b>Thermal Shock</b>	8.1					4									
<b>Humidity, Steady State</b>	8.2					5									
<b>Hi Temperature Life</b>	8.3							5							
<b>Environmental Sequence Phase I</b>	8.4	5													
<b>Phase II</b>		8													
<b>Phase III</b>		16													
<b>Ind. Mixed Flowing Gas</b>	8.5		9												
<b>Vibration</b>	8.6				4										
<b>Mechanical Shock</b>	8.7				5										
<b>Durability</b>	8.8	12	5					4							
<b>Solderability</b>	8.9										2				
<b>Res. To Soldering Heat</b>	8.10											2			

**Report DL-2011-06-033D CR**

PwrBlade® Connector Receptacle Signal Contact Redesign Qualification Testing  
GXT Plated Receptacle Mated with GXT Plated Header  
08 May, 2012

**PURPOSE**

Qualification testing was performed on GXT plated PwrBlade® connectors, whose Receptacle signal contact was redesigned, to assess the conformance to FCI product specification GS-12-149, (Rev. U, Jun 2<sup>nd</sup> 2010). Testing was performed, and result reported, under Laboratory Test number DL-2011-06-033.

**CONCLUSIONS**

The tested results showed that the redesigned PwrBlade® connector met the requirements of FCI product specification GS-12-149U. The test results in this report relate only to the items tested.

**SAMPLE DESCRIPTION**

Samples submitted consisted of 51720 series STB (solder to board) R/A Header and 51760 series Press-fit R/A Receptacle. Prior to testing, the samples were examined at low magnification and judged to be acceptable for testing. The details of the submitted samples are given in Table 1 and illustrated in Figure 1.

**Table 1 Identity of Submitted Test Samples**

Item	Description	Part #	Lot #	Contact Plating
1	PwrBlade® RA Header Assemblies	51720-11008410AALF	DG	GXT
2	PwrBlade® RA Receptacle Assemblies	51760-11008410CALF	DG	GXT

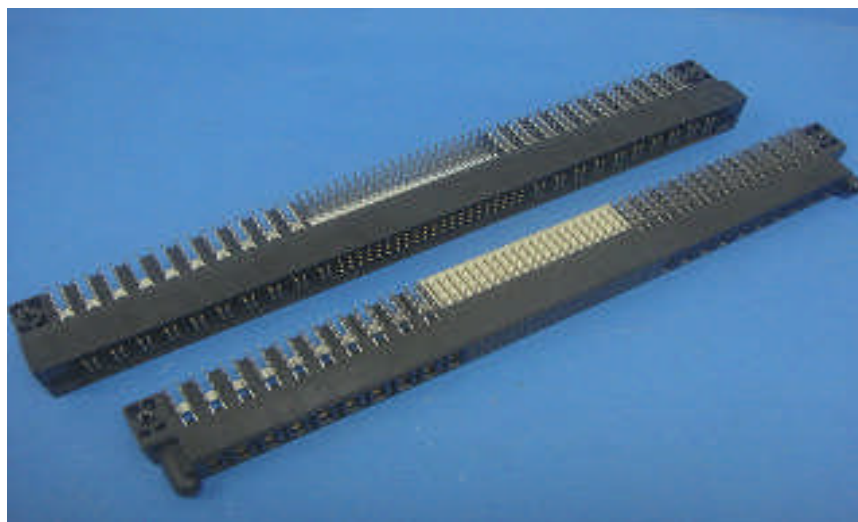

**Figure1 Test sample- PwrBlade® R/A Header and Receptacle**

## REFERENCE DOCUMENT

The requirements for product qualification are established by the product specifications with reference to a variety of test methods. FCI qualification and other pertinent documents are listed in Table 2.

**Table 2 Reference Documents**

Document ID	Title	Rev. Level (Date)
FCI GS-12-149	Product Specification, PwrBlade® Connector System	U (2010 Jun)
EIA/ECA-364-18	Visual and Dimensional Inspection Test Procedure for Electrical Connectors and Sockets	B (2007 Feb)
EIA/ECA-364-23	Low Level Contact Resistance Test Procedure for Electrical Connectors and Sockets	C (2006 Jun)
EIA/ECA-364-21	Insulation Resistance Test Procedure for Electrical Connectors, Sockets, and coaxial contacts	D (2008 Mar)
EIA-364-20	Dielectric Withstanding Voltage Test Procedure for Electrical Connector	D (2008 Mar)
EIA/ECA-364-70	Temperature Rise versus Current Test Procedure for Electrical Connectors and Sockets	B (2007 Jun)
EIA/ECA-364-13	Mating and Unmating force Test Procedure for Electrical Connectors and Sockets	D (2007 Jul)
EIA/ECA-364-29	Contact Retention Test Procedure for Electrical Connectors	C (2006 Aug)
EIA-364-96	Plating through Hole integrity Test Procedure for Electrical Connectors	(2002 Nov)
EIA-364-32	Thermal shock (Temperature Cycling) Test Procedure for Electrical Connectors and Sockets	E (2008 May)
EIA-364-31	Humidity Test Procedure for Electrical Connectors and Sockets	C (2008 Nov)
EIA-364-17	Temperature Life With or without Electrical Load Test Procedure for Electrical Connectors and Sockets	B (1999 Jun)
EIA-364-65	Mixed Flowing Test Procedure for Electrical Connectors and Sockets	B (2009 Dec)
EIA-364-28	Vibration Test Procedure for Electrical Connectors and Sockets	F (2011 Jan)
EIA-364-27	Mechanical Shock (Specified Pulse) Test Procedure for Electrical Connectors and Sockets	C (2011 Jun)
EIA-364-09	Durability Test Procedure for Electrical Connectors and Sockets	C (1999 Jun)
EIA-364-87	Nanosecond Event Detection Test Procedure for Electrical Connectors, Contacts and Sockets	A(2009 May)
IPC/ECA J-STD-002	Solderability Test for Component Leads, Terminations, Lugs, Terminals and Wires	C ( Dec 2007 )

## TEST DESCRIPTIONS

Preparatory to testing, as needed, for Groups 1, 2, 4 & 7 the submitted header and receptacle connectors were mounted to 2oz thickness test printed wiring boards P/N SK-44146-002 and SK-44148-002 respectively for Low-Level contact resistance (LLCR) measuring and discontinuity monitoring. For Groups 9, connectors mounted onto 5oz thickness printed wiring boards P/N SK-44146-012 and SK-44148-012 respectively for current rating testing. All Header connectors were manually soldered onto PWBs and the Receptacle connectors were pressed into PWBs by machine. These test boards had circuitry to provide series connection through all signal terminals. Figure 2 shows an example of a test sample consisting of a mated pair of connectors mounted on test boards.

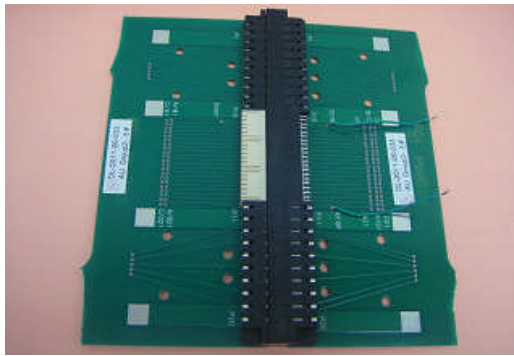

**Figure 2 Test sample Consisting of a Mate Pair of PwrBlade® Connectors Mounted on Test Boards**

Each mating pair of test connectors was assigned a sample number. Samples were labeled with the FCI “DL” test number, followed by test group number, and a sequential individual sample designation.

Testing was conducted in accordance with FCI product specification GS-12-149, Rev. U (Jun 2<sup>nd</sup> 2010) with some amendments to test sequence. Group1, 2, 4, 5, 7, 9, 10, 12&13, total nine (9) groups were performed for GXT to GXT plating. Contact resistance test for Power contact was omitted from all test sequence since the purpose of the testing was to evaluate the performance of Signal contacts only. The test sequences are given in Table 3.

**Table 3 Sequence of Applied Tests by Test Group**

Test	PAR	Test Group								
		1	2	4	5	7	9	10	12	13
Visual examination	5.5	1,15	1,9	1,7	1,8	1,6	1,3	1,3	1,3	1,13
LLCR	6.1	3,5,7,11,13	3,5,7	2,4,6		2,5				3,6,9
IR	6.3				2,6					
DWV	6.4				3,7					
Current Rating	6.5						2			
Mating/un-mating force	7.1	2,8,10,14	2,8							
Contact insertion/retention	7.3							2		
Individual pin insertion (new pin for each insertion)	7.4									2,5,8
Individual pin retention	7.4									4,7,10
PCB Hole Deformation Radius	7.5									11
PCB Hole Damage	7.6									12
Thermal shock	8.1				4					
Humidity	8.2				5					
High temp life	8.3					4				
Environment sequence	Phase I	8.4	4							
	Phase II	8.4	6							
	Phase III	8.4	12							
MFG	8.5		6							
Vibration	8.6			3						
Mechanical shock	8.7			5						
Durability	8.8	9	4			3				
Solderability	8.9							2		

Note: the numbers in the table indicate the sequence in which the tests were performed.

- LLCR = Low Level Contact Resistance
- DWV = Dielectric Withstanding Voltage
- MFG = Industrial Mixed Flowing Gas
- IR = Insulation Resistance
- Temp = Temperature

**TEST METHODS/REQUIREMENTS**

**Table 4 Test Requirements**

Test Items	Clause	Test method	Condition	Requirement
Examination of product	5.5	EIA-364-18B	10x magnification	No detrimental condition
LLCR	6.1	EIA-364-23C	20mV,100mA	LLCR $\leq 20m\Omega$ EON LLCR $\leq 1m\Omega$ <sup>1</sup>
IR	6.3	EIA-364-21D	500V DC,2 minute	$\geq 500M\Omega$
DWV	6.4	EIA-364-20D	1000V DC,60s	No arcing, leakage current $\leq 1mA$
Current Rating	6.5	EIA-364-70B	Method 2, 30°C $\Delta T$	Powered all signal: $\geq 1A$ powered one signal: $\geq 3A$
Mating/ un-mating force	7.1	EIA-364-13D	1 inch/min	Mating force $\leq 22.5kgf$ Un-mating force $\geq 6.06kgf$ <sup>2</sup>
Contact insertion/retention	7.3	EIA-364-29C <sup>3</sup>	Method A, 0.5 inch/min , 30 contacts	Signal Receptacle: $\geq 3lb$
Individual pin insertion (new pin for each insertion)	7.4	GS-12-149§7.4	0.2 inch/min	$\leq 6lb$
Individual pin retention	7.4	GS-12-149§7.4	0.2 inch/min	$\geq 1.5lb$
PCB Hole Deformation Radius	7.5	EIA-364-96 GS-12-149§7.5	0.010" from PCB surface center of press-fit	0.0015" max avg. 0.002" max individual
PCB Hole Damage	7.6	EIA-364-96 GS-12-149§7.6	Center of press-fit	0.0003" min Cu thickness & No damage
Thermal shock	8.1	EIA-364-32E	-20~80°C, 36cycles	No damage
Humidity	8.2	EIA-364-31C	Method II Condition A 40°C, 95%RH, 96hours	No damage
High temp life	8.3	EIA-364-17B	Method A, condition 4, 105°C, 21days	No damage
Phase I (thermal shock)	8.4	EIA-364-32E	-20~80°C, 36cycles	No damage
Phase II (Humidity)	8.4	EIA-364-31C	Method II Condition B 40°C, 95%RH, 10days	No damage
Phase III (High Temp life )	8.4	EIA-364-17B	Method A, condition 4, 105°C, 21days	No damage
MFG	8.5	EIA-364-65B	Class IIA, 20days mated	No damage
Vibration	8.6	EIA-364-28F	Condition III, 10 to 2000 to 10Hz, 4 hours per axes.	No discontinuities >10ns
Mechanical shock	8.7	EIA-364-27C	Condition A <sup>4</sup> , 50G 11ms half-sine	No discontinuities >10ns
Durability	8.8	EIA-364-09C	200cycles, 5inch/min	No damage
Solderability	8.9	J-STD-002C <sup>5</sup>	Condition A1, 4 hours steam aging	Wet solder coverage $\geq 95\%$

<sup>1</sup> The requirement of EON LLCR referred to GR-1217-CORE.

<sup>2</sup> Mating force: 25oz\*20 power pin+3.5oz\*84 signal pin=794.00 oz=22.5kgf  
Unmating force: 8oz\*20 power pin+0.64oz\*84 signal pin=213.76 oz=6.06kgf

<sup>3</sup> EIA-364-29C was used instead of MIL-STD-1344 since the MIL-STD-1344 had been superseded by EIA-364 series standard.

<sup>4</sup> Condition A was used instead of Condition I since the requirement specified in GS-12-149U was 50G 11ms half sine wave.

<sup>5</sup> J-STD-002C test condition A1 was used instead of ANSI-J-002 test condition A.



**Examination of Product(s)** - Samples were visually examined at 10X magnification, initially, to verify suitability for testing, and after testing, for any evidence of visual defects.

**LLCR-** Low Level Contact Resistance at the specified test current of 100mA Max and test voltage of 20mV Max open circuit were measured across the mated signal contacts in accordance with EIA-364-23C and GS-12-149U, section 6.1. The PWB circuitry provides a series circuit through all signal contacts.

**IR-** Insulation Resistance was tested between pairs of adjacent signal contacts on mated connectors (not mounted on PWBs) at the specified test voltage of 500V DC level, which was applied for 2 minutes. Testing was in accordance with EIA-364-21D and GS-12-149U, section 6.3. Eight pairs of adjacent signal contacts were tested.

**DWV-** Dielectric Withstanding Voltage was tested between pairs of adjacent signal contacts on mated connectors (not mounted on PWBs). Connections were made using test clips attached to opposite solder tail of the mated terminals (i.e., one connection on the header side and one connection on the receptacle side). Testing was conducted in accordance with EIA-364-20D and GS-12-149U, section 6.4. The potential was increased from zero at a rate (500v/s) to the specified 1000VDC level, which was applied for 60 second. Eight pairs of adjacent signal contacts were tested.

**Current Rating-** Current rating at the specified test temperature rise of 30°C above ambient was measured on three mated connectors in accordance with EIA-364-70B and GS-12-149U, sec 6.5. All signal contacts were energized simultaneously with sufficient current to produce a temperature 30°C higher than ambient. Thermocouples were attached (by thermally conductive adhesive) to the signal pin solder tail of 6 contacts (A10&11 and D1 of header and receptacle). The thermocouples were attached as shown in Figure 3. The current rating was taken as the minimum current required to attaining the specified temperature at any position in all tested connectors. Measurements were taken after warm-up of applied current, at a duration of activation deemed adequate for stabilization of measured resistance.

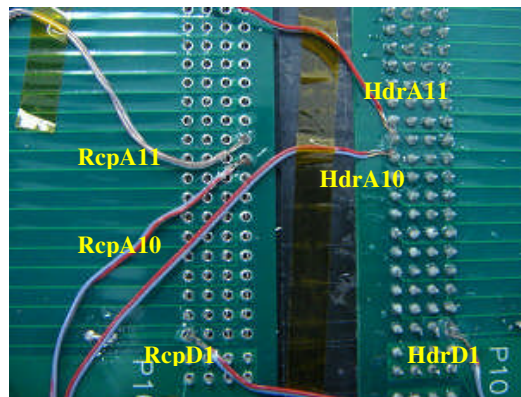

**Figure 3 Photo of Thermocouples location**

**Mating / Unmating Force-** Mating and unmating force were measured in accordance with EIA-364-13D and GS-12-149U Sec.7.1. The test samples were axially aligned to accomplish the mating and unmating function allowing for self-centering movement. Mating and un-mating of the connectors proceeded automatically with a crosshead speed set at 1 in/min. Forces were measured initially or after mechanical cycling or environmental exposure as required by the product specification.

**Contact Retention Force-** Contact retention was tested in accordance with EIA-364-29C and GS-12-149U Sec.7.3. The operation speed is 0.5 in/min. Thirty (30) of Receptacle signal contacts were tested.

**Individual Pin Insertion/ Retention force-** Individual pin insertion and retention of press-fit connectors was performed in accordance with GS-12-149U Sec.7.4. Individual pins (one at a time for signal terminal) were aligned to accomplish the insertion and extractions (three cycles) with pre-centering prior to test. Insertion and extraction of the pins proceeded automatically with crosshead speed set at 0.2 in/min, while forces were measured. Each insertion/ extraction was performed with virgin pins. The same PCB was used for all cycles. The press fit terminals were tested in each of two (2) PTH sizes (minimum and maximum) respectively.

**PCB hole Deformation Radius-** Hole Deformation was performed in accordance with EIA-364-96 and GS-12-149U Sec.7.5. Boards with minimum and maximum diameter holes, post-insertion and –retention testing were cross-sectioned parallel to the board surface, photographed and measured. Insertion / extraction cycles were performed on additional boards to provide the required number of samples. Holes deformation radius (10 holes total) was measured at .010” from the surface, and at the center of compliant pin section. Copper thickness between the compliant section and printed wiring board laminate was photographed and measured.

**PCB Hole Damage-** Hole wall damage was inspected in accordance with EIA-364-96 and GS-12-149U Sec.7.6. Boards with minimum and maximum diameter holes, post-insertion and –retention testing were cross-sectioned perpendicular to the board surface and through the compliant section wear track. Insertion / extraction cycles were performed on additional boards to provide the required number of samples.

**Thermal Shock/ Phase I (thermal shock)-**The Mated connectors were subjected to 36cycles of thermal extremes of -20°C and 80°C in accordance with EIA-364-32E and GS-12-149U Sec.8.1& 8.4. Dwell time was 30 minutes at each temperature. No electrical monitoring was performed during the exposure.

**Humidity/ Phase II (Humidity)-**The Mated connectors were subjected to humidity and temperature treatment in accordance with EIA-364-31C, Method II with temperature held to 40°C at 95% relative humidity (RH). The test duration differed for different test sequences (groups). Humidity (Group 5) consisted of 96 hours and Phase II (Group 1) consisted of 240 hours (10 days). The samples were not energized or monitored electrically during the exposure.

**High Temperature Life/ Phase III (High Temperature Life) -** The mated connectors were exposed an elevated temperature in accordance with GS-12-149U Sec.8.3 & 8.4 requirements and EIA-364-17B, method A (without electrical load), condition 4 (105°C±2°C). Exposure consisted of 21 days. No electrical monitoring was performed during the exposure.

**MFG (Corrosion Resistance) -** Corrosion resistance was tested by exposure to mixed flowing gas in accordance with EIA-364-65B, Class IIA. This test consisted of target environments of 27 to 32°C and near 70% relative humidity with four corrosive gases. Gases included chlorine (Cl<sub>2</sub>), nitric oxide (NO<sub>2</sub>), hydrogen sulfide (H<sub>2</sub>S), and sulfur dioxide (SO<sub>2</sub>) in nominal concentrations of 10, 200, 10, and 100 ppb, respectively. The exposure was specified to be a total of 20 days. Samples were exposed in mated conditions for the treatment.

**Vibration-**The mated test samples were subjected to vibration in accordance with GS-12-149U sec.8.6.and EIA-364-28F, Condition III with test duration of 4 hours per axis. The samples were mounted on rigid support fixtures to remove inertial effects of PWBs. Vibration was limited to a peak acceleration of 15 G (acceleration of gravity) at frequencies of 10Hz to 2000Hz. The samples were subjected to vibration along each of three axes for 12 \*20-minute cycles totaling four hours in ambient condition. The samples were monitoring during the exposure for all signal contacts. The samples were fixtured as shown in Figure 4. On each connector, all signal contacts were monitored on a series circuit.

**Mechanical Shock-**The Mated connectors were subjected to mechanical shock in accordance with GS-12-149U sec.8.7.and EIA-364-27C, Condition A [1/2 sine, 50G (±2.5) acceleration, 11ms duration], Three shock pulses were applied in two directions along each of three axes. The samples were fixtured as shown in Figure 4. Discontinuity monitoring for signal contacts was performed during exposure. On each connector, all signal contacts were monitored on a series circuit.

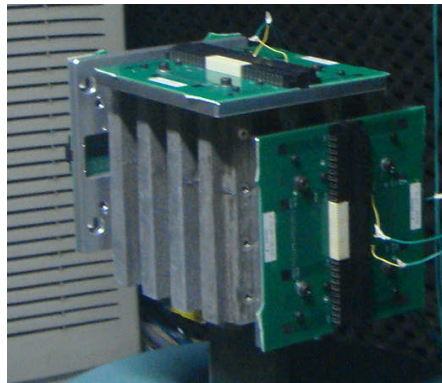

**Figure 4 PwrBlade Sample Fixturing for Shock and Vibration testing**

**Durability-** Durability cycling of the connectors was performed in accordance with EIA-364-09C and GS-12-149U Sec.8.8. The test samples were axially aligned to accomplish the mating and unmating function allowing for self-centering movement. Mating and unmating of the connectors proceeded automatically with a crosshead speed set at 5 in/min. The durability cycling consisted of 200 cycles of mating and unmating samples.

**Solderability-** Solderability exposure and evaluation was performed in accordance with IPC/ECA J-STD-002C and GS-12-149U Sec.8.9. The samples were exposed to four hours of steam age and evaluated for solder coverage.

**TEST RESULTS**

Table 5 through 13 given a summary of the results from testing for Groups 1, 2, 4, 5, 7, 9, 10, 12 & 13.

**Table 5 Summary of Test Result, Group 1**

Step	Test	Requirement	Step Description	Results	Comment
1	Examination of product	No detrimental condition	Initial	No detriment	Pass
2	Mating/un-mating force	Mating: ≤22.5kgf Un-mating: ≥6.06kgf	Initial	Mating: ≤10.64kgf Un-mating: ≥8.09kgf	Pass
3	LLCR	≤20mΩ	Initial LLCR	≤ 17.3mΩ	Pass
4	Phase I (thermal shock)	No damage	Thermal shock	No damage	Pass
5	LLCR	≤20mΩ	After thermal shock	≤ 17.9mΩ	Pass
6	Phase II (Humidity )	No damage	Humidity	No damage	Pass
7	LLCR	≤20mΩ	After humidity	≤ 16.9mΩ	Pass
8	Mating/un-mating force	Mating: ≤22.5kgf Un-mating: ≥6.06kgf	After humidity	Mating: ≤ 9.29kgf Un-mating: ≥ 7.06kgf	Pass
9	Durability	No damage	Durability	No damage	Pass
10	Mating/un-mating force	Mating: ≤22.5kgf Un-mating: ≥6.06kgf	After durability	Mating: ≤ 10.88kgf Un-mating: ≥ 8.45kgf	Pass
11	LLCR	≤20mΩ	After durability	≤ 17.4mΩ	Pass
12	Phase III (High Temp life )	No damage	High temp life	No damage	Pass
13	LLCR	≤20mΩ	Final (After high temp life)	≤ 17.7mΩ	Pass
14	Mating/un-mating force	Mating: ≤22.5kgf Un-mating: ≥6.06kgf	Final (After high temp life)	Mating: ≤ 9.06kgf Un-mating: ≥ 8.48kgf	Pass
15	Examination of product	No detrimental condition	Final	No degradation	Pass

**Table 6 Summary of Test Result, Group 2**

Step	Test	Requirement	Step Description	Results	Comment
1	Examination of product	No detrimental condition	Initial	No detriment	Pass
2	Mating/ un-mating force	Mating: $\leq 22.5\text{kgf}$ Un-mating: $\geq 6.06\text{kgf}$	Initial	Mating: $\leq 11.14\text{kgf}$ Un-mating: $\geq 8.15\text{kgf}$	Pass
3	LLCR	$\leq 20\text{m}\Omega$	Initial	$\leq 18.5\text{m}\Omega$	Pass
4	Durability	No damage	Durability	No damage	Pass
5	LLCR	$\leq 20\text{m}\Omega$	After durability	$\leq 17.3\text{m}\Omega$	Pass
6	MFG	No damage	20 days MFG	No damage	Pass
7	LLCR	$\leq 20\text{m}\Omega$	After 20d MFG	$\leq 17.7\text{m}\Omega$	Pass
8	Mating/ un-mating force	Mating: $\leq 22.5\text{kgf}$ Un-mating: $\geq 6.06\text{kgf}$	Final (After MFG)	Mating: $\leq 10.26\text{kgf}$ Un-mating: $\geq 6.9\text{kgf}$	Pass
9	Examination of product	No detrimental condition	Final	No degradation	Pass

**Table 7 Summary of Test Result, Group 4**

Step	Test	Requirement	Step Description	Results	Comment
1	Examination of product	No detrimental condition	Initial	No detriment	Pass
2	LLCR	$\leq 20\text{m}\Omega$	Initial	$\leq 17.2\text{m}\Omega$	Pass
3	Vibration	No discontinuities >10ns	Vibration	No discontinuities >10ns	Pass
4	LLCR	$\leq 20\text{m}\Omega$	After Vibration	$\leq 19.0\text{m}\Omega$	Pass
5	Mechanical shock	No discontinuities >10ns	Mechanical shock	No discontinuities >10ns	Pass
6	LLCR	$\leq 20\text{m}\Omega$	Final (After shock)	$\leq 19.9\text{m}\Omega$	Pass
7	Examination of product	No detrimental condition	Final	No degradation	Pass

**Table 8 Summary of Test Result, Group 5**

Step	Test	Requirement	Step Description	Results	Comment
1	Examination of product	No detrimental condition	Initial	No detriment	Pass
2	IR	$\geq 500\text{M}\Omega$	Initial IR	$\geq 35,600\text{M}\Omega$	Pass
3	DWV	No arcing, leakage current $\leq 1\text{mA}$	Initial DWV	No arcing, leakage current $< 1\text{mA}$	Pass
4	Thermal shock	No damage	Thermal shock	No damage	Pass
5	Humidity, Steady State	No damage	Humidity, Steady State	No damage	Pass
6	IR	$\geq 500\text{M}\Omega$	Final IR (After Humidity)	$\geq 927,000\text{M}\Omega$	Pass
7	DWV	No arcing, leakage current $\leq 1\text{mA}$	Final DWV (After Humidity)	No arcing, leakage current $< 1\text{mA}$	Pass
8	Examination of product	No detrimental condition	Final	No degradation	Pass

**Table 9 Summary of Test Result, Group 7**

Step	Test	Requirement	Step Description	Results	Comment
1	Examination of product	No detrimental condition	Initial	No detriment	Pass
2	LLCR	$\leq 20\text{m}\Omega$	Initial LLCR	$\leq 17.4\text{m}\Omega$	Pass
3	Durability	No damage	Durability	No damage	Pass
4	High temp life	No damage	High temp life	No damage	Pass
5	LLCR	$\leq 20\text{m}\Omega$	Final LLCR (After High Temp)	$\leq 16.7\text{m}\Omega$	Pass
6	Examination of product	No detrimental condition	Final	No degradation	Pass

**Table 10 Summary of Test Result, Group 9**

Step	Test	Requirement	Step Description	Results	Comment
1	Examination of product	No detrimental condition	Initial	No detriment	Pass
2	Current Rating	All signal: $\geq 1A$ One signal: $\geq 3A$	Current Rating	All signal: $\geq 1.71A$ One signal: $\geq 6.64A$	Pass
3	Examination of product	No detrimental condition	Final	No degradation	Pass

**Table 11 Summary of Test Result, Group 10**

Step	Test	Requirement	Step Description	Results	Comment
1	Examination of product	No detrimental condition	Initial	No detriment	Pass
2	Solderability	Wet solder coverage $\geq 95\%$	Solderability	Wet solder coverage $> 95\%$	Pass
3	Examination of product	No detrimental condition	Final	No degradation	Pass

**Table 12 Summary of Test Result, Group 12**

Step	Test	Requirement	Step Description	Results	Comment
1	Examination of product	No detrimental condition	Initial	No detriment	Pass
2	Contact insertion/retention	$\geq 3lb$	Contact insertion/retention	$\geq 3.54lb$	Pass
3	Examination of product	No detrimental condition	Final	N/A	N/A

**\*\*After contact retention force testing, some contacts have been pulled out. The visual examination is not applicable herein.**

**Table 13 Summary of Test Result, Group 13**

Step	Test	Requirement	Step Description	Results	Comment
1	Examination of product	No detrimental condition	Initial	No detriment	Pass
2	Individual pin insertion	≤6lb	1 <sup>st</sup> Insertion	≤4.269lb	Pass
3	LLCR	≤1mΩ	1 <sup>st</sup> LLCR	≤0.205mΩ	Pass
4	Individual pin retention	≥1.5lb	1 <sup>st</sup> Retention	≥1.996lb	Pass
5	Individual pin insertion	≤6lb	2 <sup>nd</sup> Insertion	≤3.778lb	Pass
6	LLCR	≤1mΩ	2 <sup>nd</sup> LLCR	≤0.206mΩ	Pass
7	Individual pin retention	≥1.5lb	2 <sup>nd</sup> Retention	≥1.67lb	Pass
8	Individual pin insertion	≤6lb	3 <sup>rd</sup> Insertion	≤3.626lb	Pass
9	LLCR	≤1mΩ	3 <sup>rd</sup> LLCR	≤0.231mΩ	Pass
10	Individual pin retention	≥1.5lb	3 <sup>rd</sup> Retention	≥1.703lb	Pass
11	PCB Hole Deformation Radius	<0.0015'' avg. <0.002'' individual	PCB Hole Deformation Radius	0.000727'' avg. ≤0.00188'' individual	Pass
12	PCB Hole Damage	>0.0003'' Cu thickness & No damage	PCB Hole Damage	≥0.00092'' Cu thickness & No damage	Pass
13	Examination of product	No detrimental condition	Final	No degradation	Pass

Statistical summaries of LLCR results are further summarized in the Appendix A.

Statistical summaries of mating/ Un-mating force results are further summarized in the Appendix B.

Statistical summaries of Group 9 Current Rating results are further summarized in the Appendix C.

Statistical summaries of Group 13 EON LLCR results are further summarized in the Appendix D.

Statistical summaries of Group 13 Individual pin insertion/retention force results are further summarized in the Appendix E.

**REVISION RECORD**

Revision Level	Affected Pages	Description	Revision Date
A	All	Original Release	08-May-2012



**Appendix A. Statistical Summary of Measured LLCR (Unit: m $\Omega$ )**

Table A1. Statistical Summary of LLCR, Group 1

Sample Count=252	Min	Max	Average	Stdev
Initial	5.7	17.3	11.3	3.5
After Thermal Shock	6.1	17.9	11.6	3.4
After Humidity	5.7	16.9	11.5	3.3
After Durability	5.7	17.4	11.5	3.4
After High temp life	6.1	17.7	12.0	3.4

Table A2. Statistical Summary of LLCR, Group 2

Sample Count=252	Min	Max	Average	Stdev
Initial	6.3	18.5	11.6	3.4
After Durability	5.9	17.3	11.2	3.4
After 20days MFG test	5.9	17.7	11.5	3.4

Table A3. Statistical Summary of LLCR, Group 4

Sample Count=252	Min	Max	Average	Stdev
Initial	6.1	17.2	11.6	3.3
After vibration test	5.4	19.0	11.6	3.5
After shock test	5.3	19.9	11.7	3.5

Table A4. Statistical Summary of LLCR, Group 7

Sample Count=252	Min	Max	Average	Stdev
Initial	6.3	17.4	11.5	3.3
After High temp life	5.7	16.7	11.6	3.4

**Appendix B. Statistical Summary of Measured Mating/ Unmating Force (Unit: N)**

Table B1. Statistical Summary of Mating/ un-mating force, Group 1

Sample Count=3		Min	Max	Average	Stdev
Initial	Mating force	9.70	10.64	10.11	0.48
	un-Mating force	8.09	10.00	9.07	0.96
After Humidity	Mating force	8.14	9.29	8.77	0.58
	un-Mating force	7.06	7.76	7.39	0.35
After Durability	Mating force	9.50	10.88	10.09	0.71
	un-Mating force	8.45	10.20	9.12	0.94
After High temp life	Mating force	8.74	9.06	8.90	0.16
	un-Mating force	8.48	8.56	8.53	0.04

Table B2. Statistical Summary of Mating/ un-mating force, Group 2

Sample Count=3		Min	Max	Average	Stdev
Initial	Mating force	9.74	11.14	10.41	0.70
	un-Mating force	8.15	9.63	9.13	0.85
After 20d MFG	Mating force	8.39	10.26	9.13	0.99
	un-Mating force	6.90	7.27	7.14	0.21

**Appendix C. Statistical Summary of Measured Current Rating- Group 9 (Unit: °C)**

The 20 power contacts were energized at 30ADC, and all signal contacts were powered in series for current rating testing simultaneously						
Amp	0	0.5	0.75	1	1.5	2
1# HdrA11	3.128	6.445	9.293	13.250	23.862	37.924
1# HdrA10	3.120	6.358	9.234	13.049	23.469	37.249
1# RecA11	2.725	6.030	8.934	12.837	23.498	37.610
1# RecA10	3.122	6.515	9.374	13.208	23.654	37.492
2# HdrA11	2.907	5.969	9.133	13.149	24.002	37.663
2# HdrA10	3.325	6.423	9.528	13.552	24.689	38.761
2# RecA11	2.925	5.952	8.965	12.901	23.375	36.806
2# RecA10	3.166	6.217	9.088	12.847	22.777	34.469
3# HdrA10	3.360	6.275	9.118	12.954	23.223	36.668
3# RecA10	3.415	6.493	9.378	13.289	23.702	36.923
3# HdrA11	3.541	6.626	9.432	13.185	23.190	36.194
3# RecA11	3.602	6.688	9.650	13.614	24.462	38.566

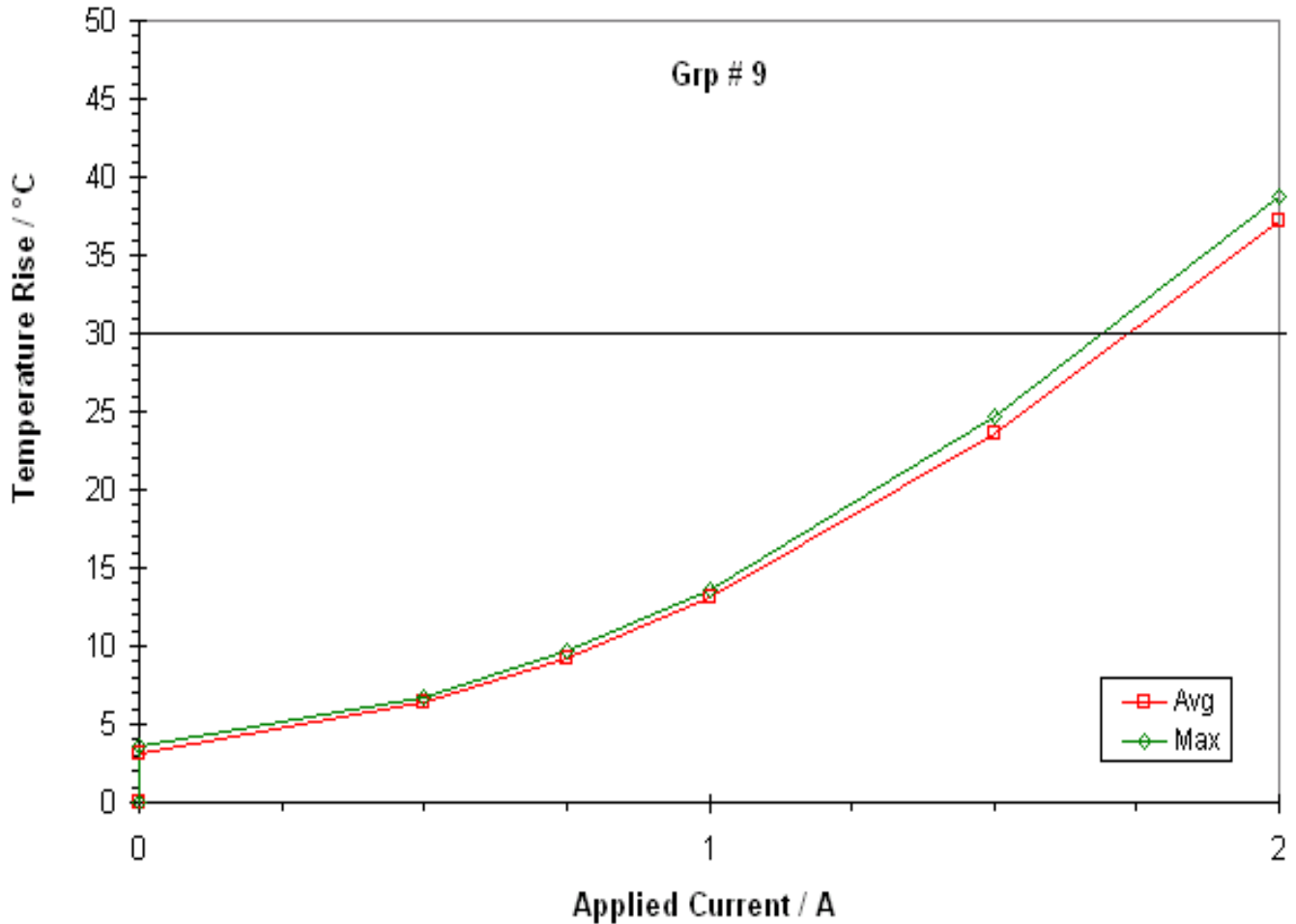

Temperature rise of sample # 2 Hdr A10 reached 30°C when applied 1.71A Current.

The 20 power contacts were energized in series at 30ADC, and only signal contacts D1 was powered for current rating testing simultaneously

Amp	0	1	2	3	4
1# Hdr D1	12.17	13.182	14.337	16.285	19.012
1# Rec D1	11.852	12.93	14.015	15.85	18.488
2# Hdr D1	11.631	12.901	14.039	16.177	19.292
2# Rec D1	11.762	13.102	14.243	16.179	19.143
3# Hdr D1	11.376	12.475	13.915	15.962	19.094
3# Rec D1	10.848	11.809	13.271	15.231	18.232

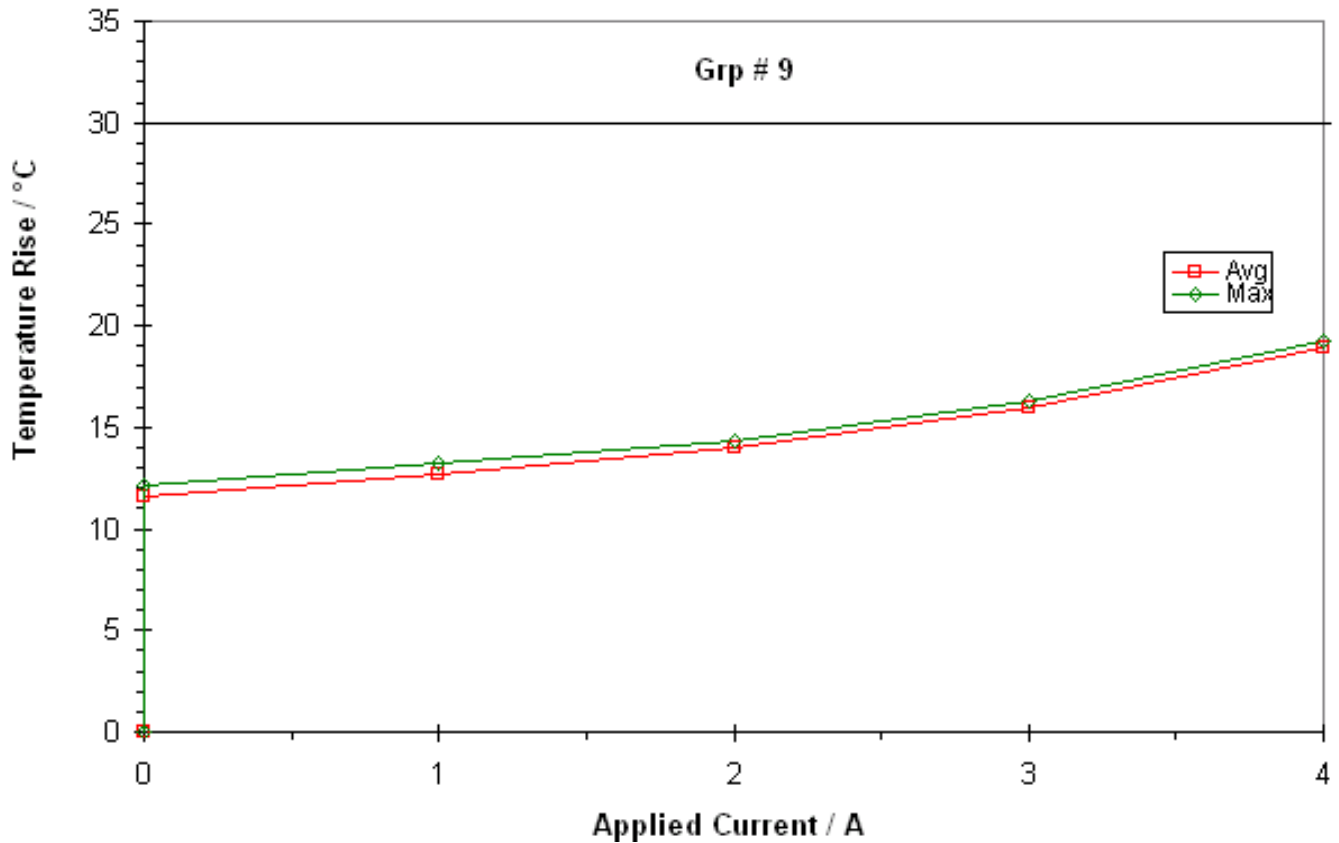

Temperature rise of sample # 2 Hdr D1 reached 30°C when applied 6.64A Current.

**Appendix D. Statistical Summary of Group 13 Measured EON LLCR (Unit: m  $\Omega$ )**

Sample Count=22		Min	Max	Average	Stdev
Min PTH	1 <sup>st</sup> LLCR	0.103	0.137	0.117	0.012
	2 <sup>nd</sup> LLCR	0.113	0.151	0.128	0.011
	3 <sup>rd</sup> LLCR	0.128	0.167	0.148	0.012
Max PTH	1 <sup>st</sup> LLCR	0.155	0.205	0.174	0.017
	2 <sup>nd</sup> LLCR	0.137	0.206	0.170	0.020
	3 <sup>rd</sup> LLCR	0.145	0.231	0.185	0.024

**Appendix E Statistical Summary of Group 13 Measured Individual pin insertion/retention force (Unit: lb)**

Sample Count=22			Min PTH				Max PTH			
			Min	Max	Average	Stdev	Min	Max	Average	Stdev
For LLCR	Insertion force	1 <sup>st</sup> time	3.584	4.269	3.765	0.200	2.132	3.118	2.632	0.373
		2 <sup>nd</sup> time	3.170	3.778	3.419	0.200	2.054	3.032	2.331	0.274
		3 <sup>rd</sup> time	3.025	3.626	3.413	0.194	1.793	2.606	2.124	0.255
	Retention force	1 <sup>st</sup> time	2.115	3.336	2.785	0.369	1.996	2.690	2.260	0.198
		2 <sup>nd</sup> time	2.658	3.448	3.167	0.255	1.670	2.349	2.060	0.258
		3 <sup>rd</sup> time	2.964	4.296	3.723	0.350	1.703	2.133	1.874	0.146

# PwrBlade Receptacle Signal Contact design change

Old Hertz Design

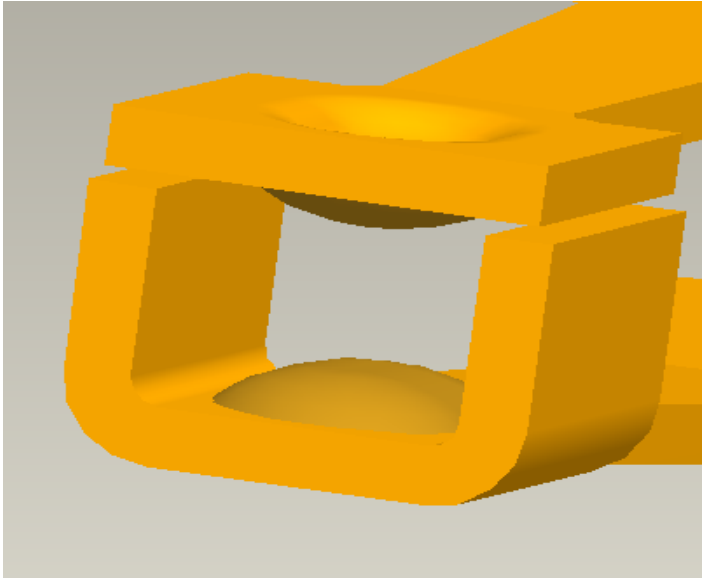

New Opposing Beams Design

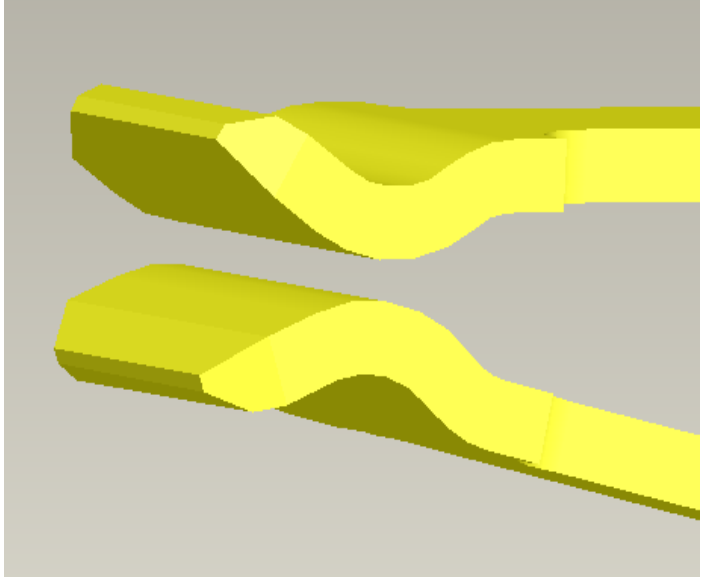

***Changing the contact functional design of signal contacts in the receptacle connectors from the Hertz design into new Opposing beams design with the purpose to better insure that the connectors mate optimally based on better positioning of the contacts***

# PwrBlade Receptacle Signal Contact Design change

Vtl Rec. Old Press Fit and STB

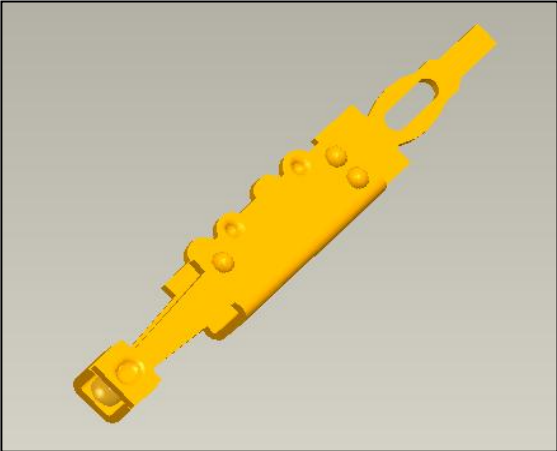

Vtl Rec. New Press fit and STB

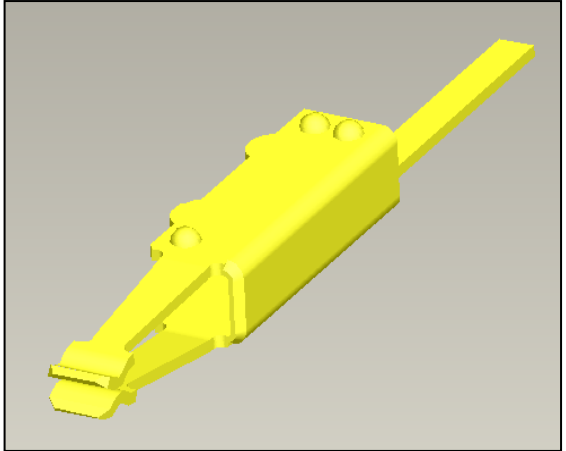
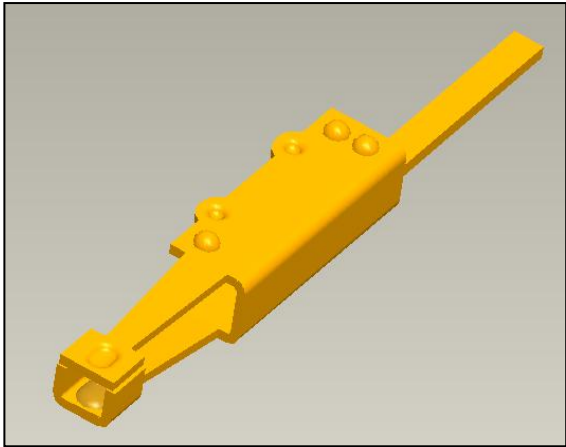
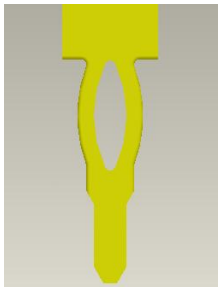
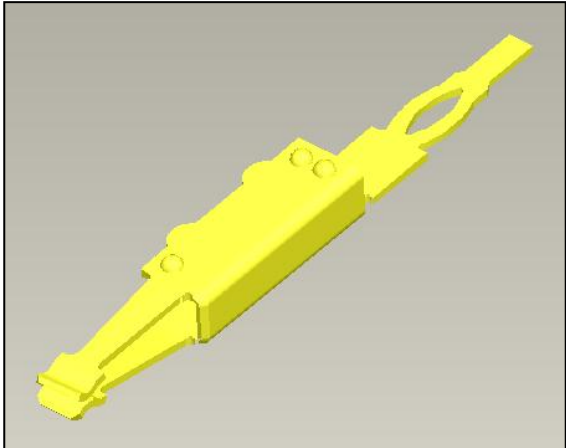

RA Rec. Old Press Fit and STB

RA Rec. New Press fit and STB

