



August 2016

# MCT6, MCT61, MCT62 8-Pin Dual Channel Phototransistor Optocouplers

## Features

- Two Isolated Channels Per Package
- Safety and Regulatory Approvals:
  - UL1577, 5,000 VAC<sub>RMS</sub> for 1 Minute
  - DIN-EN/IEC60747-5-5, 890 V Peak Working Insulation Voltage

## Applications

- AC line/digital logic – isolate high voltage transients
- Digital logic/digital logic – eliminate spurious grounds
- Digital logic/AC triac control – isolate high voltage transients
- Twisted pair line receiver – eliminate ground loop feedthrough
- Telephone/telegraph line receiver – isolate high voltage transients
- High frequency power supply feedback control – maintain floating grounds and transients
- Relay contact monitor – isolate floating grounds and transients
- Power supply monitor – isolate transients

## Description

The general purpose optocouplers, MCT6, MCT61, and MCT62, have two isolated channels in a standard plastic 8-pin dual-in-line (DIP) package for density applications. Each channel consists of a gallium arsenide infrared emitting diode driving a NPN silicon planar phototransistor. For four channel applications, two packages fit into a standard 16-pin DIP socket.

## Functional Schematic

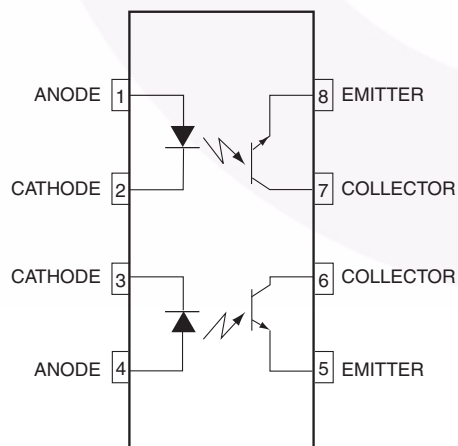

Figure 1. Schematic

## Package Outlines

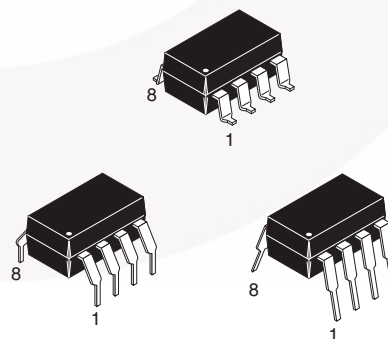

Figure 2. Package Outlines

MCT6, MCT61, MCT62 8-Pin Dual Channel Phototransistor Optocouplers

## Safety and Insulation Ratings

As per DIN EN/IEC 60747-5-5, this optocoupler is suitable for “safe electrical insulation” only within the safety limit data. Compliance with the safety ratings shall be ensured by means of protective circuits.

Parameter		Characteristics
Installation Classifications per DIN VDE 0110/1.89 Table 1, For Rated Mains Voltage	< 150 V <sub>RMS</sub>	I–IV
	< 300 V <sub>RMS</sub>	I–IV
Climatic Classification		55/115/21
Pollution Degree (DIN VDE 0110/1.89)		2
Comparative Tracking Index		175

Symbol	Parameter	Value	Unit
V <sub>PR</sub>	Input-to-Output Test Voltage, Method A, V <sub>IORM</sub> × 1.6 = V <sub>PR</sub> , Type and Sample Test with t <sub>m</sub> = 10 s, Partial Discharge < 5 pC	1424	V <sub>peak</sub>
	Input-to-Output Test Voltage, Method B, V <sub>IORM</sub> × 1.875 = V <sub>PR</sub> , 100% Production Test with t <sub>m</sub> = 1 s, Partial Discharge < 5 pC	1668	V <sub>peak</sub>
V <sub>IORM</sub>	Maximum Working Insulation Voltage	890	V <sub>peak</sub>
V <sub>IOTM</sub>	Highest Allowable Over-Voltage	8000	V <sub>peak</sub>
	External Creepage	≥ 7	mm
	External Clearance	≥ 7	mm
DTI	Distance Through Insulation (Insulation Thickness)	≥ 0.4	mm
T <sub>S</sub>	Case Temperature <sup>(1)</sup>	175	°C
I <sub>S,INPUT</sub>	Input Current <sup>(1)</sup>	60	mA
P <sub>S,OUTPUT</sub>	Output Power <sup>(1)</sup>	150	mW
R <sub>IO</sub>	Insulation Resistance at T <sub>S</sub> , V <sub>IO</sub> = 500 V <sup>(1)</sup>	> 10 <sup>9</sup>	Ω

### Note:

1. Safety limit values – maximum values allowed in the event of a failure.

## Absolute Maximum Ratings

Stresses exceeding the absolute maximum ratings may damage the device. The device may not function or be operable above the recommended operating conditions and stressing the parts to these levels is not recommended. In addition, extended exposure to stresses above the recommended operating conditions may affect device reliability. The absolute maximum ratings are stress ratings only.  $T_A = 25^\circ\text{C}$  unless otherwise specified.

Symbol	Parameter	Value	Unit
$T_{STG}$	Storage Temperature	-55 to +150	$^\circ\text{C}$
$T_{OPR}$	Operating Temperature	-55 to +100	$^\circ\text{C}$
$T_J$	Junction Temperature	-55 to +125	$^\circ\text{C}$
$T_{SOL}$	Lead Solder Temperature	260 for 10 seconds	$^\circ\text{C}$
$P_D$	Total Device Power Dissipation @ $T_A = 25^\circ\text{C}$	400	mW
	Derate Above $25^\circ\text{C}$	5.33	$\text{mW}/^\circ\text{C}$
<b>EMITTER (Each channel)</b>			
$I_F$	DC / Average Forward Input Current	60	mA
$I_F(\text{pk})$	Forward Current - Peak ( $PW = 1\mu\text{s}, 300\text{pps}$ )	3	A
$V_R$	Reverse Input Voltage	3	V
$P_{D(\text{EMITTER})}$	Total Power Dissipation @ $T_A = 25^\circ\text{C}$	100	mW
	Derate Above $25^\circ\text{C}$	1.3	$\text{mW}/^\circ\text{C}$
<b>DETECTOR</b>			
$I_C$	Continuous Collector Current	30	mA
$P_{D(\text{DETECTOR})}$	Total Power Dissipation @ $T_A = 25^\circ\text{C}$	150	mW
	Derate Above $25^\circ\text{C}$	2.0	$\text{mW}/^\circ\text{C}$

## Electrical Characteristics

$T_A = 25^\circ\text{C}$  unless otherwise specified.

### Individual Component Characteristics

Symbol	Parameter	Test Conditions	Min.	Typ.	Max.	Unit
<b>EMITTER</b>						
$V_F$	Input Forward Voltage	$I_F = 20\text{ mA}$		1.2	1.5	V
$V_R$	Reverse Voltage	$I_R = 10\text{ }\mu\text{A}$	3	25		V
$I_R$	Reverse Leakage Current	$V_R = 5\text{ V}$		0.001	10	$\mu\text{A}$
$C_J$	Junction Capacitance	$V_F = 0\text{ V}$ , $f = 1\text{ MHz}$		50		pF
<b>DETECTOR</b>						
$BV_{CEO}$	Collector-to-Emitter Breakdown Voltage	$I_C = 1.0\text{ mA}$ , $I_F = 0$	30	85		V
$BV_{ECO}$	Emitter-to-Collector Breakdown Voltage	$I_E = 100\text{ }\mu\text{A}$ , $I_F = 0$	6	13		V
$I_{CEO}$	Collector-to-Emitter Dark Current	$V_{CE} = 10\text{ V}$ , $I_F = 0$		5	100	nA
$C_{CE}$	Capacitance	$V_{CE} = 0\text{ V}$ , $f = 1\text{ MHz}$		8		pF

### Transfer Characteristics

Symbol	Parameter	Device	Test Conditions	Min.	Typ.	Max.	Unit
<b>DC CHARACTERISTICS</b>							
CTR	Current Transfer Ratio, Collector-to-Emitter	MCT6	$I_F = 10\text{ mA}$ , $V_{CE} = 10\text{ V}$	20			%
		MCT61	$I_F = 5\text{ mA}$ , $V_{CE} = 5\text{ V}$	50			
		MCT62		100			
$V_{CE(SAT)}$	Saturation Voltage, Collector-to-Emitter	ALL	$I_F = 16\text{ mA}$ , $I_C = 2\text{ mA}$		0.15	0.4	V

### AC CHARACTERISTICS

Symbol	Parameter	Test Conditions	Min.	Typ.	Max.	Unit
<b>Non-Saturated</b>						
$T_{ON}$	Turn-On Time	$R_L = 100\text{ }\Omega$ , $I_C = 2\text{ mA}$ , $V_{CC} = 10\text{ V}$		3.0		$\mu\text{s}$
$T_{OFF}$	Turn-Off Time			3.0		$\mu\text{s}$
$T_R$	Rise Time			2.4		$\mu\text{s}$
$T_F$	Fall Time			2.4		$\mu\text{s}$
<b>Saturated</b>						
$T_{ON}$	Turn-On Time	$I_F = 16\text{ mA}$ , $R_L = 1.9\text{ k}\Omega$ , $V_{CE} = 5\text{ V}$		2.4		$\mu\text{s}$
$T_{OFF}$	Turn-Off Time			25.0		$\mu\text{s}$

### Isolation Characteristics

Symbol	Parameter	Test Conditions	Min.	Typ.	Max.	Unit
$V_{ISO}$	Input-Output Isolation Voltage	$I_{I-O} \leq 10\text{ }\mu\text{A}$ , $t = 1\text{ Minute}$	5,000			$V_{AC_{RMS}}$
$C_{ISO}$	Isolation Capacitance	$f = 1\text{ MHz}$		0.5		pF
$R_{ISO}$	Isolation Resistance	$V_{I-O} = 500\text{ VDC}$	$10^{11}$			$\Omega$

### Typical Performance Curves

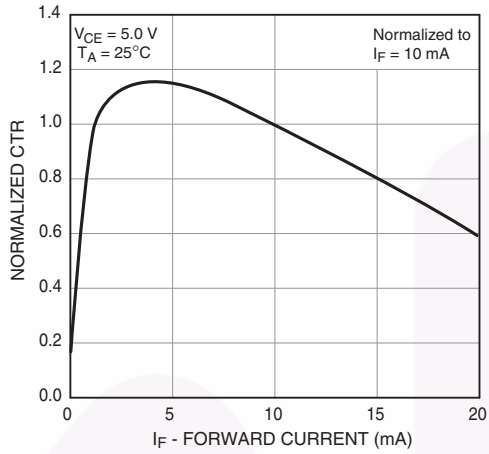

Fig. 3 Normalized CTR vs. Forward Current

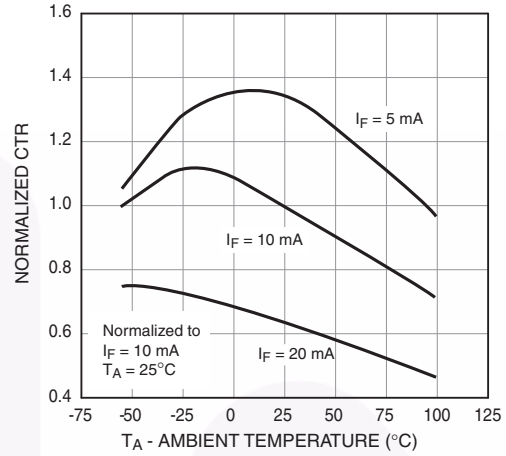

Fig. 4 Normalized CTR vs. Ambient Temperature

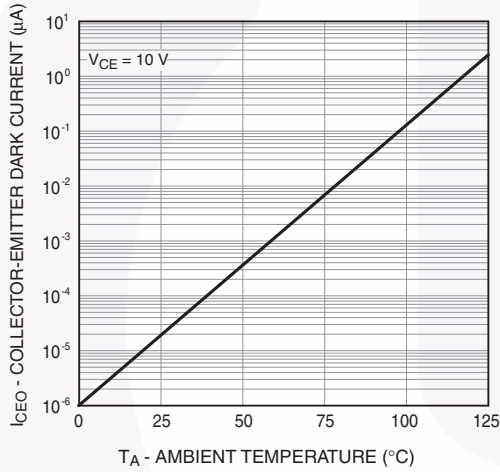

Fig. 5 Dark Current vs. Ambient Temperature

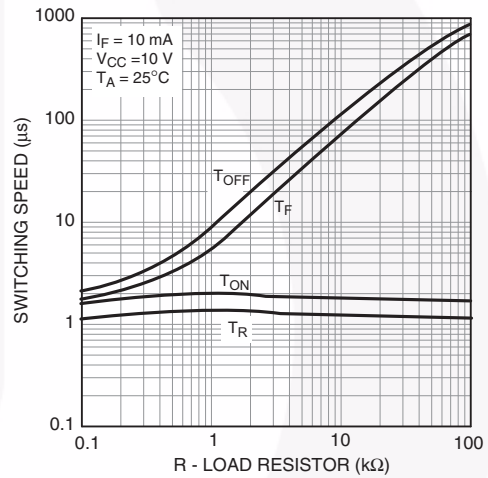

Fig. 6 Switching Speed vs. Load Resistor

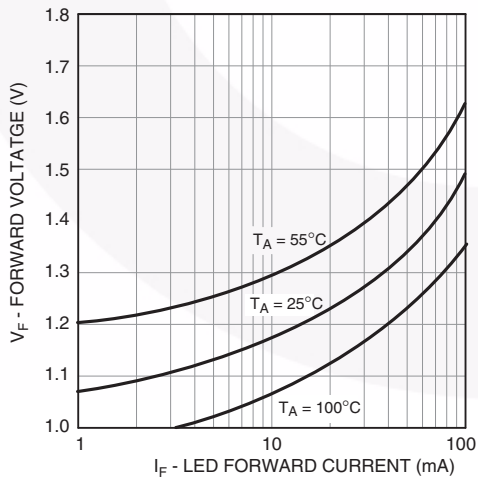

Fig. 7 LED Forward Voltage vs. Forward Current

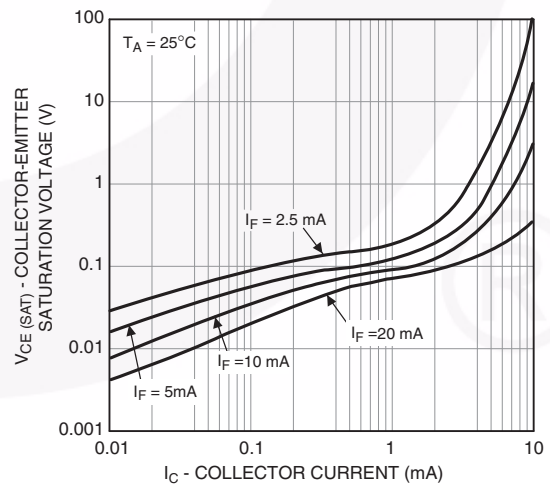

Fig. 8 Collector-Emitter Saturation Voltage vs. Collector Current

### Switching Time Test Circuit and Waveforms

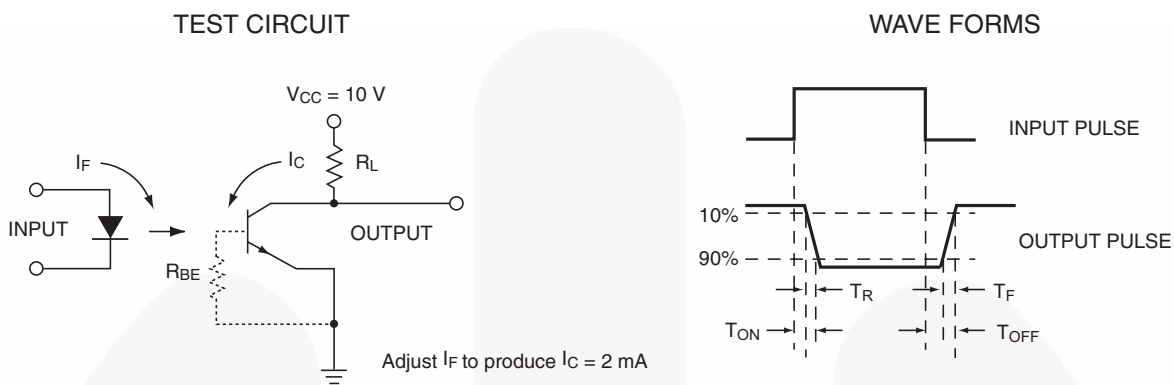
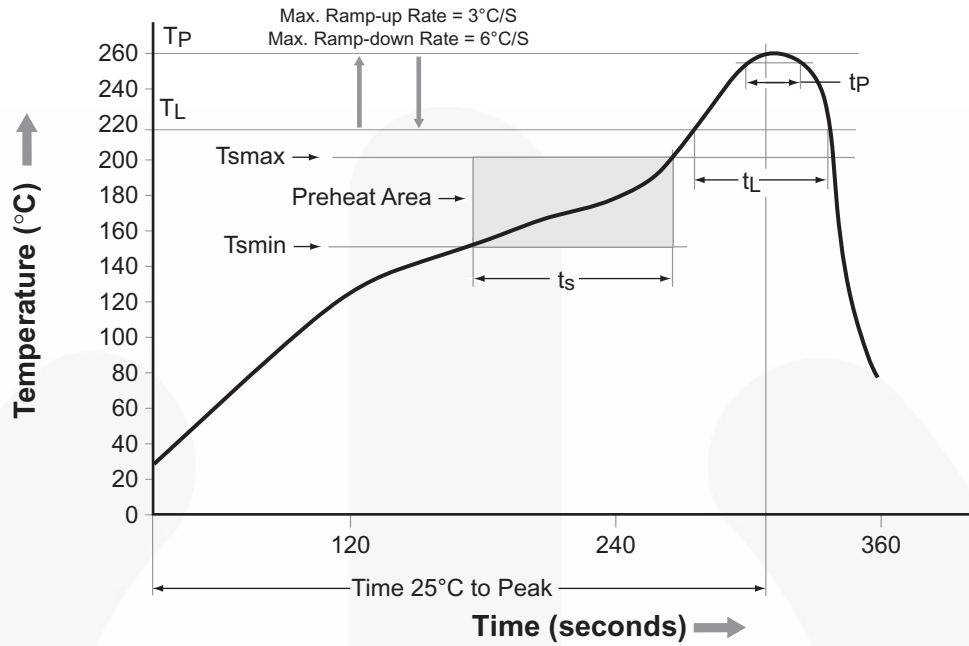

Figure 9. Switching Time Test Circuit and Waveforms



### Reflow Profile



Profile Feature	Pb-Free Assembly Profile
Temperature Min. (T <sub>smin</sub> )	150°C
Temperature Max. (T <sub>smax</sub> )	200°C
Time (t <sub>s</sub> ) from (T <sub>smin</sub> to T <sub>smax</sub> )	60–120 seconds
Ramp-up Rate (t <sub>L</sub> to t <sub>P</sub> )	3°C/second max.
Liquidous Temperature (T <sub>L</sub> )	217°C
Time (t <sub>L</sub> ) Maintained Above (T <sub>L</sub> )	60–150 seconds
Peak Body Package Temperature	260°C +0°C / -5°C
Time (t <sub>P</sub> ) within 5°C of 260°C	30 seconds
Ramp-down Rate (T <sub>P</sub> to T <sub>L</sub> )	6°C/second max.
Time 25°C to Peak Temperature	8 minutes max.



## Ordering Information

Part Number	Package	Packing Method
MCT6	DIP 8-Pin	Tube (50 units per tube)
MCT6S	SMT 8-Pin (Lead Bend)	Tube (50 units per tube)
MCT6SD	SMT 8-Pin	Tape and Reel (1,000 units per reel)
MCT6300	DIN EN/IEC 60747-5-5 Option	Tube (50 units per tube)
MCT63S	SMT 8-Pin (Lead Bend); DIN EN/IEC 60747-5-5 Option	Tube (50 units per tube)
MCT63SD	SMT 8-Pin; DIN EN/IEC 60747-5-5 Option	Tape and Reel (1,000 units per reel)
MCT6300W	0.4" Lead Spacing; DIN EN/IEC 60747-5-5 Option	Tube (50 units per tube)

### Note

- The product orderable part number system listed in this table also applies to the MCT61 and MCT62.

## Marking Information

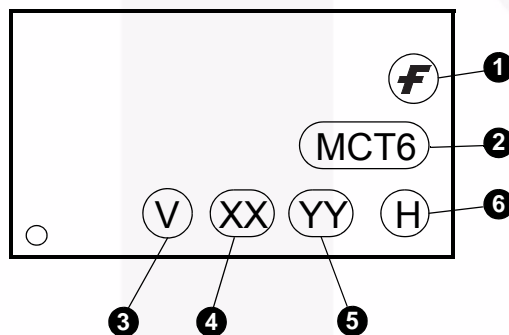
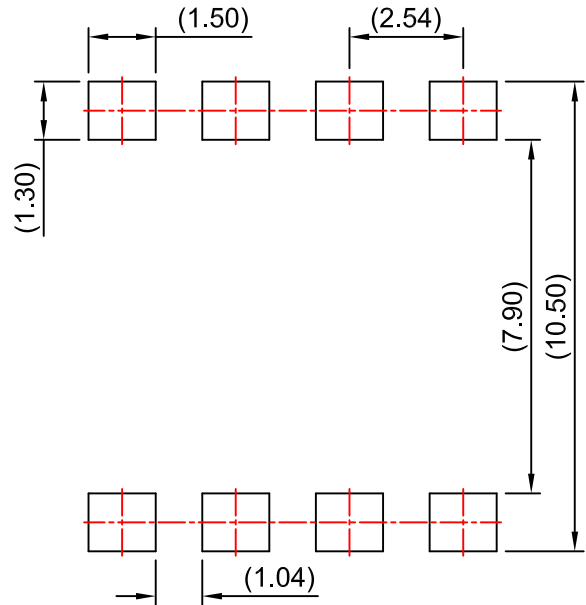
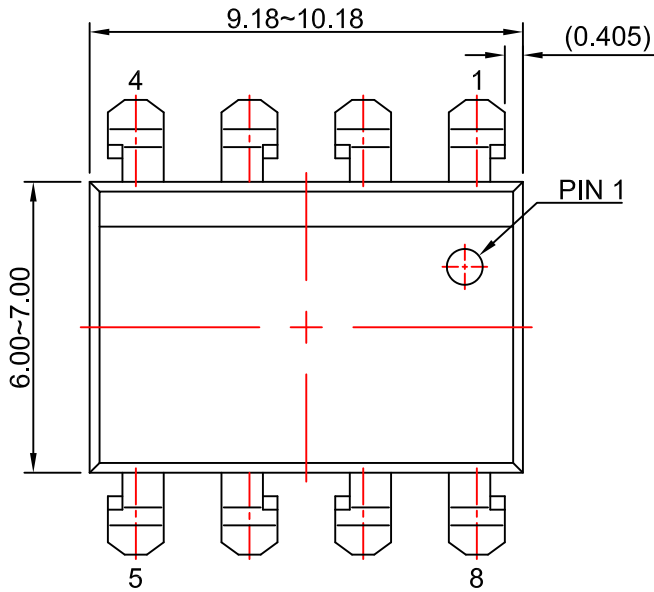

Figure 10. Top Mark

Table 1. Top Mark Definitions

1	Fairchild Logo
2	Device Number
3	DIN EN/IEC60747-5-5 Option (only appears on component ordered with this option)
4	Two-Digit Year Code, e.g., "16"
5	Digit Work Week, Ranging from "01" to "53"
6	Assembly Package Code





LAND PATTERN RECOMMENDATION

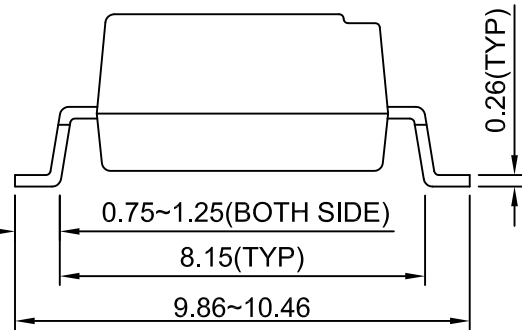
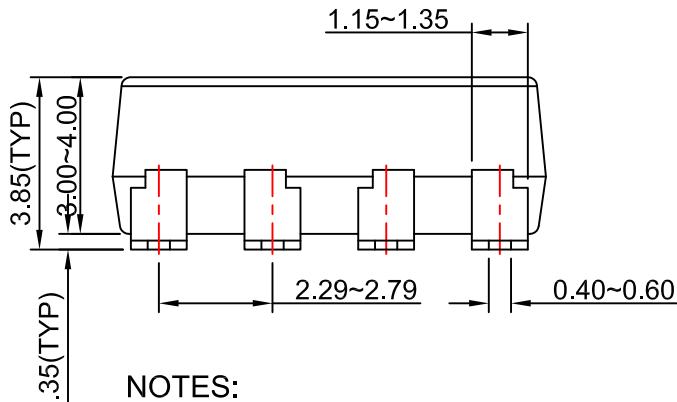

NOTES:

- A) NO STANDARD APPLIES TO THIS PACKAGE.
- B) ALL DIMENSIONS ARE IN MILLIMETERS.
- C) DIMENSIONS ARE EXCLUSIVE OF BURRS, MOLD FLASH, AND TIE BAR EXTRUSION
- D) DRAWING FILENAME AND REVISION: MKT-N08Krev2.





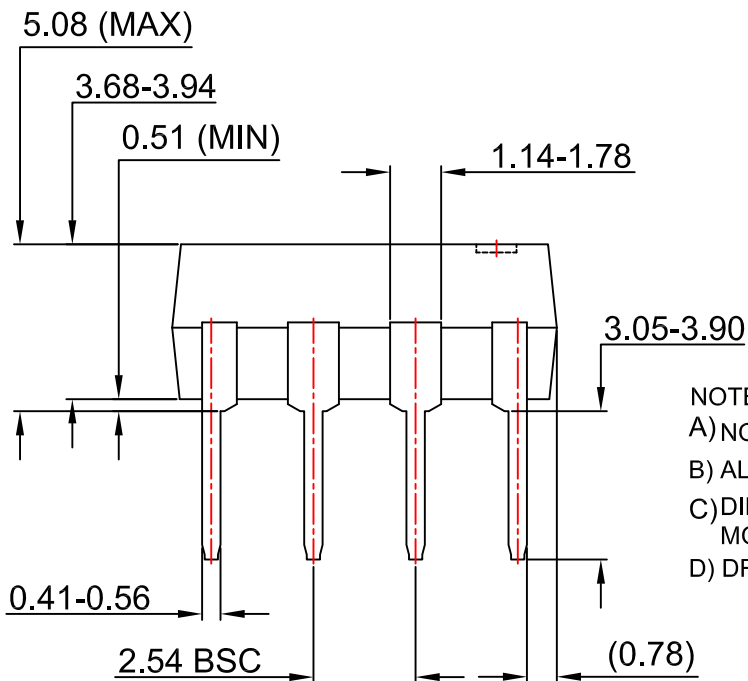
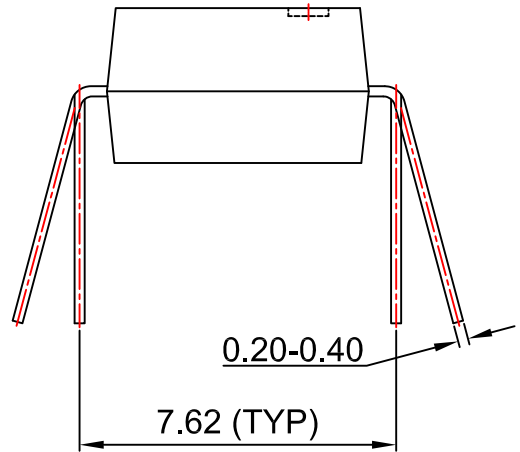
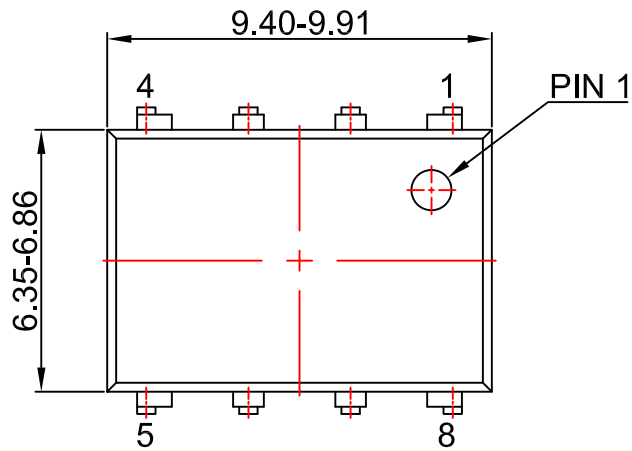

- NOTES:
- A) NO STANDARD APPLIES TO THIS PACKAGE
  - B) ALL DIMENSIONS ARE IN MILLIMETERS.
  - C) DIMENSIONS ARE EXCLUSIVE OF BURRS, MOLD FLASH, AND TIE BAR EXTRUSION
  - D) DRAWING FILENAME AND REVISION: MKT-N08GREV7





**TRADEMARKS**

The following includes registered and unregistered trademarks and service marks, owned by Fairchild Semiconductor and/or its global subsidiaries, and is not intended to be an exhaustive list of all such trademarks.

- AccuPower™
- AttitudeEngine™
- Awinda®
- AX-CAP®\*
- BitSiC™
- Build it Now™
- CorePLUS™
- CorePOWER™
- CROSSVOL™
- CTL™
- Current Transfer Logic™
- DEUXPEED®
- Dual Cool™
- EcoSPARK®
- EfficientMax™
- ESBC™
- F**™
- Fairchild®
- Fairchild Semiconductor®
- FACT Quiet Series™
- FACT®
- FastvCore™
- FETBench™
- FPS™
- F-PFS™
- FRFET®
- Global Power Resource<sup>SM</sup>
- GreenBridge™
- Green FPS™
- Green FPS™ e-Series™
- Gmax™
- GTO™
- IntelliMAX™
- ISOPLANAR™
- Making Small Speakers Sound Louder and Better™
- MegaBuck™
- MICROCOUPLER™
- MicroFET™
- MicroPak™
- MicroPak2™
- MillerDrive™
- MotionMax™
- MotionGrid®
- MTi®
- MTx®
- MVN®
- mWSaver®
- OptoHiT™
- OPTOLOGIC®
- OPTOPLANAR®
- ®
- Power Supply WebDesigner™
- PowerTrench®
- PowerXS™
- Programmable Active Droop™
- QFET®
- QS™
- Quiet Series™
- RapidConfigure™
- ™
- Saving our world, 1mW/W/kW at a time™
- SignalWise™
- SmartMax™
- SMART START™
- Solutions for Your Success™
- SPM®
- STEALTH™
- SuperFET®
- SuperSOT™-3
- SuperSOT™-6
- SuperSOT™-8
- SupreMOS®
- SyncFET™
- Sync-Lock™
- ®
- TinyBoost®
- TinyBuck®
- TinyCalc™
- TinyLogic®
- TINYOPTO™
- TinyPower™
- TinyPWM™
- TinyWire™
- TranSiC™
- TriFault Detect™
- TRUECURRENT®\*
- μSerDes™
- ™
- UHC®
- Ultra FRFET™
- UniFET™
- Vcx™
- VisualMax™
- VoltagePlus™
- XST™
- Xsens™
- 仙童®

\* Trademarks of System General Corporation, used under license by Fairchild Semiconductor.

**DISCLAIMER**

FAIRCHILD SEMICONDUCTOR RESERVES THE RIGHT TO MAKE CHANGES WITHOUT FURTHER NOTICE TO ANY PRODUCTS HEREIN TO IMPROVE RELIABILITY, FUNCTION, OR DESIGN. TO OBTAIN THE LATEST, MOST UP-TO-DATE DATASHEET AND PRODUCT INFORMATION, VISIT OUR WEBSITE AT [HTTP://WWW.FAIRCHILDSEMI.COM](http://www.fairchildsemi.com). FAIRCHILD DOES NOT ASSUME ANY LIABILITY ARISING OUT OF THE APPLICATION OR USE OF ANY PRODUCT OR CIRCUIT DESCRIBED HEREIN; NEITHER DOES IT CONVEY ANY LICENSE UNDER ITS PATENT RIGHTS, NOR THE RIGHTS OF OTHERS. THESE SPECIFICATIONS DO NOT EXPAND THE TERMS OF FAIRCHILD'S WORLDWIDE TERMS AND CONDITIONS, SPECIFICALLY THE WARRANTY THEREIN, WHICH COVERS THESE PRODUCTS.

**AUTHORIZED USE**

Unless otherwise specified in this data sheet, this product is a standard commercial product and is not intended for use in applications that require extraordinary levels of quality and reliability. This product may not be used in the following applications, unless specifically approved in writing by a Fairchild officer: (1) automotive or other transportation, (2) military/aerospace, (3) any safety critical application – including life critical medical equipment – where the failure of the Fairchild product reasonably would be expected to result in personal injury, death or property damage. Customer's use of this product is subject to agreement of this Authorized Use policy. In the event of an unauthorized use of Fairchild's product, Fairchild accepts no liability in the event of product failure. In other respects, this product shall be subject to Fairchild's Worldwide Terms and Conditions of Sale, unless a separate agreement has been signed by both Parties.

**ANTI-COUNTERFEITING POLICY**

Fairchild Semiconductor Corporation's Anti-Counterfeiting Policy. Fairchild's Anti-Counterfeiting Policy is also stated on our external website, [www.fairchildsemi.com](http://www.fairchildsemi.com), under Terms of Use

Counterfeiting of semiconductor parts is a growing problem in the industry. All manufacturers of semiconductor products are experiencing counterfeiting of their parts. Customers who inadvertently purchase counterfeit parts experience many problems such as loss of brand reputation, substandard performance, failed applications, and increased cost of production and manufacturing delays. Fairchild is taking strong measures to protect ourselves and our customers from the proliferation of counterfeit parts. Fairchild strongly encourages customers to purchase Fairchild parts either directly from Fairchild or from Authorized Fairchild Distributors who are listed by country on our web page cited above. Products customers buy either from Fairchild directly or from Authorized Fairchild Distributors are genuine parts, have full traceability, meet Fairchild's quality standards for handling and storage and provide access to Fairchild's full range of up-to-date technical and product information. Fairchild and our Authorized Distributors will stand behind all warranties and will appropriately address any warranty issues that may arise. Fairchild will not provide any warranty coverage or other assistance for parts bought from Unauthorized Sources. Fairchild is committed to combat this global problem and encourage our customers to do their part in stopping this practice by buying direct or from authorized distributors.

**PRODUCT STATUS DEFINITIONS**

**Definition of Terms**

Datasheet Identification	Product Status	Definition
Advance Information	Formative / In Design	Datasheet contains the design specifications for product development. Specifications may change in any manner without notice.
Preliminary	First Production	Datasheet contains preliminary data; supplementary data will be published at a later date. Fairchild Semiconductor reserves the right to make changes at any time without notice to improve design.
No Identification Needed	Full Production	Datasheet contains final specifications. Fairchild Semiconductor reserves the right to make changes at any time without notice to improve the design.
Obsolete	Not In Production	Datasheet contains specifications on a product that is discontinued by Fairchild Semiconductor. The datasheet is for reference information only.

Rev. I77