

1.9mm Round Subminiature "Z-Bend" Lead (Square Base) LEDs

MODEL NO : 91-21SYGC/S530-E1/TR10

Features :

- Package in 12mm tape on 7" diameter reels.
- Compatible with automatic placement equipment.
- Compatible with infrared and vapor phase reflow solder process.
- I.C. compatible.
- EIA std package.
- Mono-color type.

Description :

- The 91-21 SMD taping is much smaller than leaded components. Thusenable smaller board size.Higher packing density. Reduced storage space and finally smaller equipment to be obtained.
- Besides, light weight makes them ideal for miniature application, ect.
- Furthermore by automation assembly machines the accuracy is anticipated.

Applications :

- Small indicator for outdoor applications.
- Flat backlight for LCD, switch and symbol.
- Indicator and backlight in offic equipment.
- Indicator and backlight for battery driven equipment.
- Indicator and backlight for audio and video equipment.
- Automotive : backlighting in dashboard and switch.
- Telecommunication : indicator and backlighting in telephone and fax.
- General use.

Package Dimension :

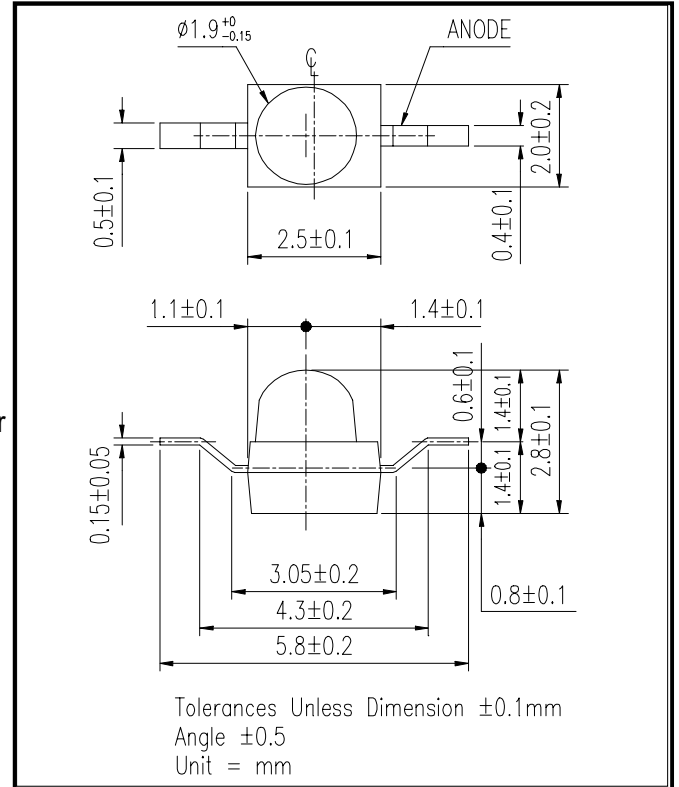

PART NO.	CHIP		Lens Color
	Material	Emitted Color	
91-21SYGC/S530-E1/TR10	AlGaInP	Super Yellow Green	Water Clear

OFFICE : NO. 25,Lane 76,Sec.3, Chung Yang Rd., Tucheng 236, Taipei, Taiwan, R.O.C.
 TEL : 886-2-2267-2000,2267-9936
 FAX : 886-2-2267-6244,22676189,22676306
<http://www.everlight.com>



EVERLIGHT ELECTRONICS CO.,LTD.

DEVICE NUMBER : DLE-912-205 REV : 1.0
ECN : _____ PAGE : 2/5

1.9mm Round Subminiature "Z-Bend" Lead (Square Base) LEDs

MODEL NO : 91-21SYGC/S530-E1/TR10

■ Package Dimensions

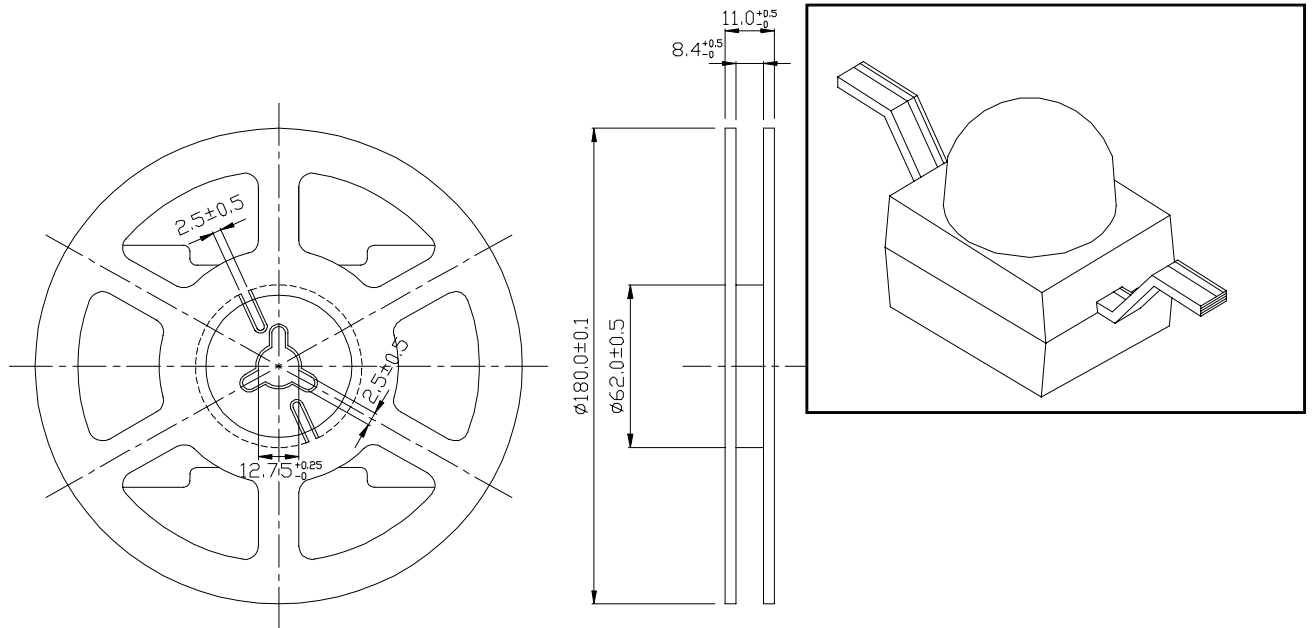

■ Loaded Quantity Per Reel 1000 Pcs/Reel

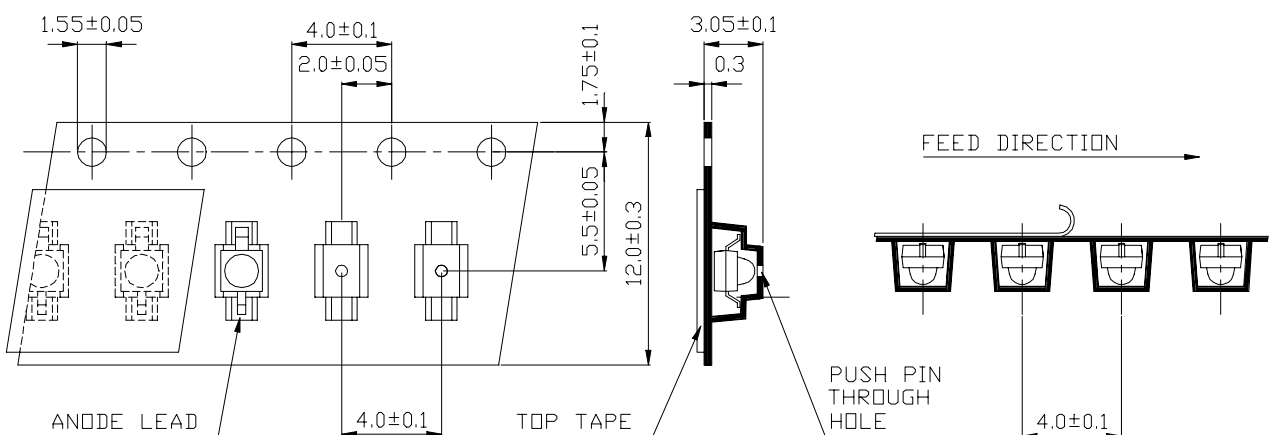

1. ALL DIMENSIONS ARE IN MILLIMETERS.
2. LEAD SPACING IS MEASURED WHERE THE LEAD EMERGE FROM THE PACKAGE
3. PROTRUDED RESIN UNDER FLANGE 1.5 mm (0.59") MAX.



EVERLIGHT ELECTRONICS CO.,LTD.

DEVICE NUMBER : DLE-912-205 REV : 1.0
 ECN : _____ PAGE : 3/5

1.9mm Round Subminiature "Z-Bend" Lead (Square Base) LEDs

MODEL NO : 91-21SYGC/S530-E1/TR10

■ Absolute Maximum Ratings at Ta = 25°C

Parameter	Symbol	Rating	Unit
Reverse Voltage	Vr	5	V
Forward Current	If	25	mA
Operating Temperature	Topr	-40 ~ +85	°C
Storage Temperature	Tstg	-40 ~ +100	°C
Soldering Temperature	Tsol	260 ± 5 for 5 sec	°C
Electrostatic Discharge	ESD	2000	V
Power Dissipation	Pd	60	mW
Peak Forward Current(Duty 1/10 @ 1KHZ)	If(Peak)	160	mA

■ Electronic Optical Characteristics :

Parameter	Symbol	MIN.	TYP.	MAX.	Unit	Condition
Luminous intensity	Iv	----	12	----	mcd	If = 2mA
Luminous intensity	Iv	132	198	----	mcd	If = 20mA
Viewing Angle	2θ 1/2	----	25	----	deg	
Peak Wavelength	λp	----	575	----	nm	
Dominant Wavelength	λd	----	573	----	nm	
Spectrum Radiation Bandwidth	Δλ	----	20	----	nm	
Forward Voltage	Vf	----	2.0	2.4	V	
Reverse Current	Ir	----	----	10	μA	Vr=5V



EVERLIGHT ELECTRONICS CO.,LTD.

DEVICE NUMBER : DLE-912-205 REV : 1.0
ECN : _____ PAGE : 4/5

1.9mm Round Subminiature "Z-Bend" Lead (Square Base) LEDs

MODEL NO : 91-21SYGC/S530-E1/TR10

■ Reliability Test Item And Condition

NO.	Item	Test Conditions	Test Hours/ Cycle	Sample Size	Ac/Re
1	Solder Heat	TEMP : 260°C ± 5 °C	5 sec	76 pcs	0/1
2	Temperature Cycle	H : +85°C 30 min ↑ 5 min ↓ L : -55°C 30 min	50 cycle	76 pcs	0/1
3	Thermal Shock	H : +100°C 5 min ↑ 10 sec ↓ L : -10°C 30 min	50 cycle	76 pcs	0/1
4	High Temperature Storage	TEMP. : +100°C	1000 hrs	76 pcs	0/1
5	Low Temperature Storage	TEMP. : -55°C	1000 hrs	76 pcs	0/1
6	DC Operating Life	If = 20 mA	1000 hrs	76 pcs	0/1
7	High Temperature / High Humidity	85°C / 85% R.H.	1000 hrs	76 pcs	0/1



1.9mm Round Subminiature "Z-Bend" Lead (Square Base) LEDs

MODEL NO : 91-21SYGC/S530-E1/TR10

Typical Electro-Optical Characteristic Curves

