



**CLEAR LENS T-1<sup>3</sup>/<sub>4</sub>  
SOLID STATE LAMPS**

**ORANGE MV5152 MV6152**  
**YELLOW MV5352 MV6352**  
**HIGH EFFICIENCY GREEN MV5452 MV64520 MV64521**  
**HIGH EFFICIENCY RED MV5752 MV6752**

**PACKAGE DIMENSIONS**

**MV5X52—LEAD CUT CATHODE LONG**  
**MV6X52X—LEAD CUT ANODE LONG**

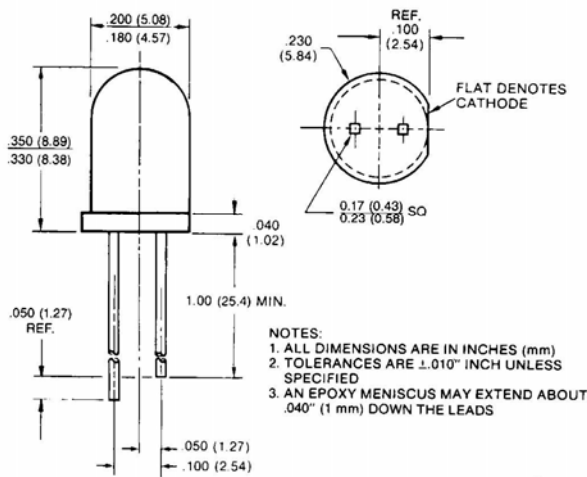

C1062L

**DESCRIPTION**

These Clear Tinted solid state indicators offer high brightness and color availability. The High Efficiency Red and Yellow devices are made with gallium arsenide phosphide on gallium phosphide. The High Efficiency Green units are made with gallium phosphide on gallium phosphide. All devices are available with cathode long as MV5X5X, or with anode long as MV6X5X.

**FEATURES**

- High on-axis light output
- High efficiency GaP light sources
- Versatile mounting on PC board or panel
- Snap in grommet MP52 available as separate order item
- Long life—solid state reliability
- Low power requirements
- Compact, rugged, lightweight

<b>PHYSICAL CHARACTERISTICS</b>					
<b>CATHODE LONG</b>	<b>ANODE LONG</b>	<b>SOURCE COLOR</b>	<b>LENS TYPE</b>	<b>LENS EFFECT</b>	<b>APPLICATION</b>
MV5152	MV6152	High Efficiency Red	Amber Clear	Point Source	Backlighting
MV5352	MV6352	Yellow	Yellow Clear	Point Source	Backlighting
MV5452	MV64520	High Efficiency Green	Green Clear	Point Source	Backlighting
—	MV64521	High Efficiency Green	Green Clear	Point Source	Backlighting
MV5752	MV6752	High Efficiency Red	Red Clear	Point Source	Backlighting



**CLEAR LENS T-1<sup>3</sup>/<sub>4</sub>  
SOLID STATE LAMPS**

<b>ELECTRO-OPTICAL CHARACTERISTICS</b> (25°C Free Air Temperature)								
PARAMETER	TEST COND.	UNITS	MV6152 MV5152	MV6352 MV5352	MV64520 MV5452	MV64521	MV6752 MV5752	
Forward voltage (V <sub>f</sub> )	typ.	I <sub>f</sub> =20 mA	V	2.0	2.1	2.2	2.2	2.0
	max.	I <sub>f</sub> =20 mA	V	3.0	3.0	3.0	3.0	3.0
Luminous Intensity	min.	I <sub>f</sub> =20 mA	mcd	17.0	10.0	12.0	30.0	17.0
	typ.	I <sub>f</sub> =20 mA	mcd	100.0	90.0	25.0	100.0	100.0
Peak wavelength	I <sub>f</sub> =20 mA	nm	635	585	562	562	635	
Spectral line half width	I <sub>f</sub> =20 mA	nm	45	35	30	30	45	
Capacitance typ.	V=0, f=1 MHz	pF	45	45	20	20	45	
Reverse voltage (V <sub>r</sub> ) min.	I <sub>r</sub> =100 μA	V	5	5	5	5	5	
Reverse current (I <sub>r</sub> ) max.	V <sub>r</sub> =5.0 V	μ A	100	100	100	100	100	
Viewing angle (total)	See Fig. 4	degrees	28	28	35	35	28	

<b>ABSOLUTE MAXIMUM RATINGS</b> (T <sub>a</sub> =25°C Unless Otherwise Specified)			
	YELLOW	RED AND H. E. RED	GREEN
Power dissipation	85 mW	120 mW	120 mW
Derate linearly from 25°C (MVX452/4A from 50°C)	1.6 mW/°C	1.6 mW/°C	1.6 mW/°C
Storage and operating temperatures	-55°C to +100°C	-55°C to +100°C	-55°C to +100°C
Lead soldering time at 260° C (See Note 2)	5 sec.	5 sec.	5 sec.
Continuous forward current	20 mA	35 mA	30 mA
Peak forward current (1 μsec pulse, 0.3% duty cycle)	60 mA	1.0 A	90 mA
Reverse voltage	5.0 V	5.0 V	5.0 V

<b>NOTES</b>
1. The axis of spatial distribution are typically within a 10° cone within reference to the central axis of the device.
2. The leads of the device were immersed in molten solder, at 260°C, to a point 1/16 inch (1.6 mm) from the body of the device per MII-S-750, with a dwell time of 5 seconds.



**CLEAR LENS T-1<sup>3</sup>/<sub>4</sub>  
SOLID STATE LAMPS**

**TYPICAL ELECTRO-OPTICAL CHARACTERISTIC CURVES**  
(25°C Free Air Temperature Unless Otherwise Specified)

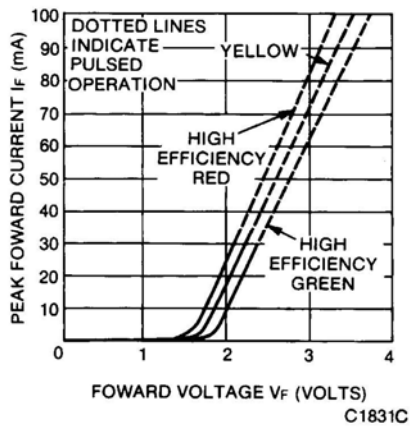

Fig. 1. Forward Current vs. Forward Voltage

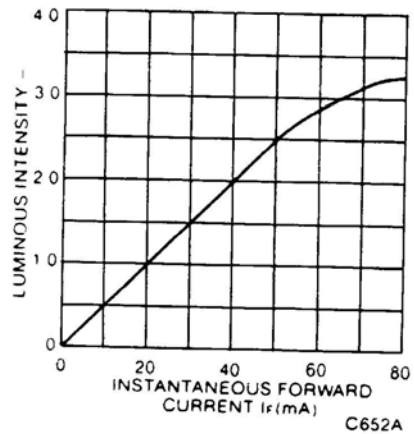

Fig. 2. Luminous Intensity vs. Forward Current

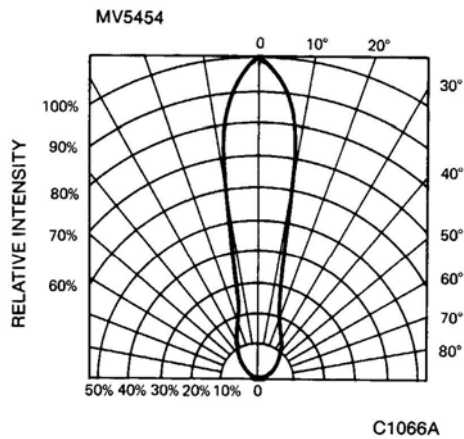

Fig. 3. Spatial Distribution (Note 1)

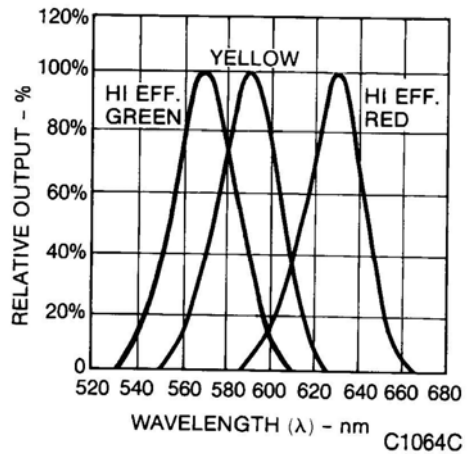

Fig. 4. Spectral Distribution



## CLEAR LENS T-1 3/4 SOLID STATE LAMPS

---

### **DISCLAIMER**

FAIRCHILD SEMICONDUCTOR RESERVES THE RIGHT TO MAKE CHANGES WITHOUT FURTHER NOTICE TO ANY PRODUCTS HEREIN TO IMPROVE RELIABILITY, FUNCTION OR DESIGN. FAIRCHILD DOES NOT ASSUME ANY LIABILITY ARISING OUT OF THE APPLICATION OR USE OF ANY PRODUCT OR CIRCUIT DESCRIBED HEREIN; NEITHER DOES IT CONVEY ANY LICENSE UNDER ITS PATENT RIGHTS, NOR THE RIGHTS OF OTHERS.

### **LIFE SUPPORT POLICY**

FAIRCHILD'S PRODUCTS ARE NOT AUTHORIZED FOR USE AS CRITICAL COMPONENTS IN LIFE SUPPORT DEVICES OR SYSTEMS WITHOUT THE EXPRESS WRITTEN APPROVAL OF THE PRESIDENT OF FAIRCHILD SEMICONDUCTOR CORPORATION. As used herein:

1. Life support devices or systems are devices or systems support which, (a) are intended for surgical implant into the can be or (b) support or sustain life, and (c) whose failure life support perform when properly used in accordance with instructions for use provided in the labeling, can be reasonably expected to result in a significant injury of the user.
2. A critical component in any component of a life body, device or system whose failure to perform to reasonably expected to cause the failure of the device or system, or to affect its safety or effectiveness.