



SURFACE MOUNT LED LAMP RIGHT ANGLE

Low V_F Blue

QTLP610CEBTR

PACKAGE DIMENSIONS

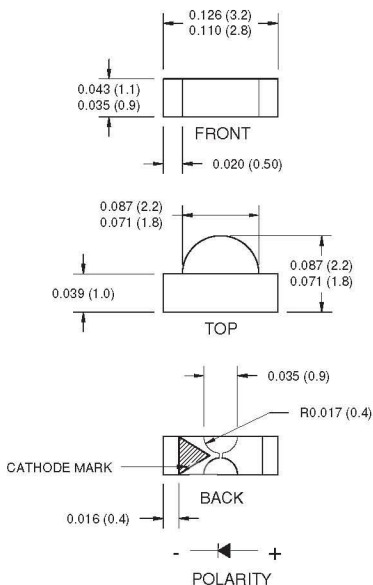

NOTE:

Dimensions for all drawings are in inches (mm).
Tolerance is ± 0.1 mm unless otherwise noted.

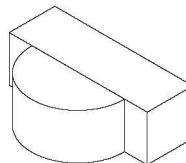

APPLICATIONS

- LCD edge-lighting
- Edge card lighting

DESCRIPTION

This right angle surface mount chip LED emits light in the lateral direction. Small size and wide viewing angle make this LED an ideal choice for edge-lighting LCD displays. This device utilizes an InGaN/Sapphire blue LED.

FEATURES

- Small footprint - 3.0(L) X 2.0(W) X 1.0(H) mm
- Wide viewing angle of 120°
- Water clear optics
- Available in 0.315" (8mm) width tape on 7" (178mm) diameter reel; 2,000 units per reel



SURFACE MOUNT LED LAMP

RIGHT ANGLE

Low V_F Blue

QTLP610CEBTR

ABSOLUTE MAXIMUM RATINGS ($T_A = 25^\circ\text{C}$ unless otherwise specified)

Parameter	Symbol	Rating	Unit
Operating Temperature	T_{OPR}	-40 to +85	$^\circ\text{C}$
Storage Temperature	T_{STG}	-40 to +90	$^\circ\text{C}$
Lead Soldering Time	T_{SOL}	260 for 5 sec	$^\circ\text{C}$
Continuous Forward Current	I_F	30	mA
Peak Forward Current ($f = 1.0 \text{ KHz}$, Duty Factor = 1/10)	I_{FM}	100	mA
Reverse Voltage	V_R	5	V
Power Dissipation	P_D	80	mW

ELECTRICAL / OPTICAL CHARACTERISTICS ($T_A = 25^\circ\text{C}$)

Part Number	QTLP610CEBTR	Condition
Luminous Intensity (mcd)		
Bin I1	8 - 16	$I_F = 5 \text{ mA}$
Bin I2	13 - 26	
Forward Voltage (V)		
Bin V1	2.75 - 2.95	$I_F = 5 \text{ mA}$
Bin V2	2.95 - 3.15	
Dominant Wavelength (nm)		
Bin W2	470 - 475	$I_F = 5 \text{ mA}$
Bin W3	475 - 480	
Spectral Line Half Width (nm)	35	$I_F = 5 \text{ mA}$
Viewing Angle ($^\circ$)	120	$I_F = 5 \text{ mA}$
Reverse Current (μA)	50 max	$V_R = 5\text{V}$

Tolerance: Luminous Intensity = $\pm 11\%$
Forward Voltage = $\pm 0.1\text{V}$
Wavelength = $\pm 1\text{nm}$



SURFACE MOUNT LED LAMP RIGHT ANGLE

Low V_F Blue

QTLP610CEBTR

TYPICAL PERFORMANCE CURVES

Fig. 1 Forward Current vs. Forward Voltage

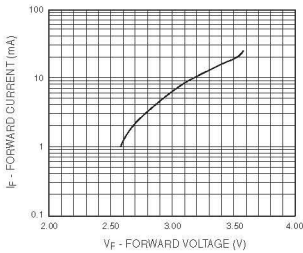

Fig. 2 Relative Luminous Intensity vs. DC Forward Current

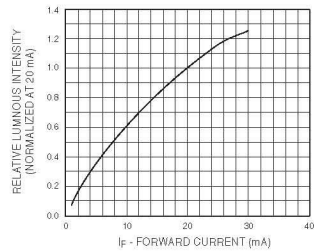

Fig. 3 Relative Intensity vs. Peak Wavelength

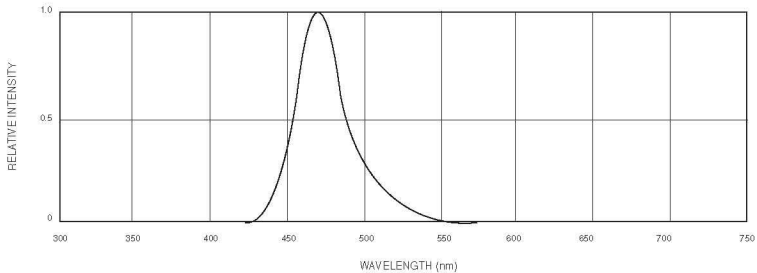

Fig.4 Radiation Diagram

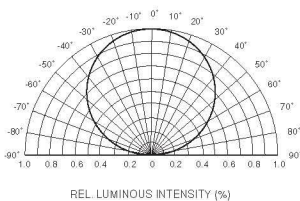
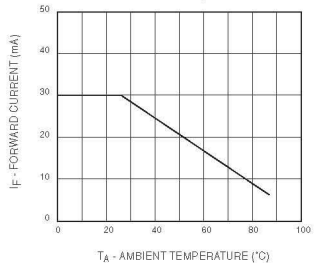

Fig.5 Maximum Forward Current vs. Ambient Temperature





SURFACE MOUNT LED LAMP RIGHT ANGLE

Low V_F Blue

QTLP610CEBTR

RECOMMENDED PRINTED CIRCUIT BOARD PATTERN

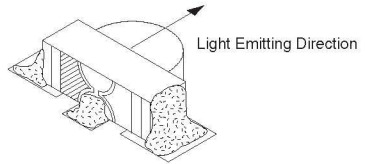
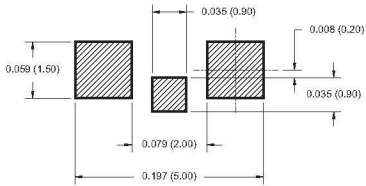

Mounting Example

RECOMMENDED IR REFLOW SOLDERING PROFILE

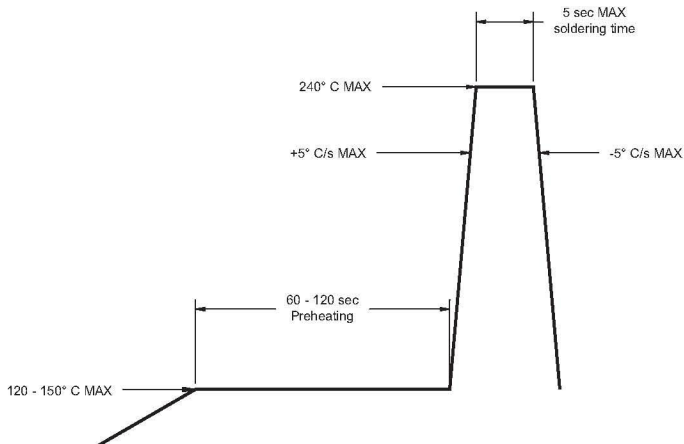



SURFACE MOUNT LED LAMP RIGHT ANGLE

Low V_F Blue

QTLP610CEBTR

TAPE AND REEL DIMENSIONS

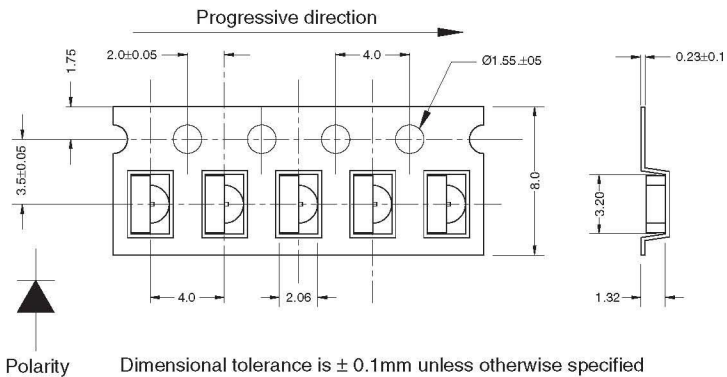
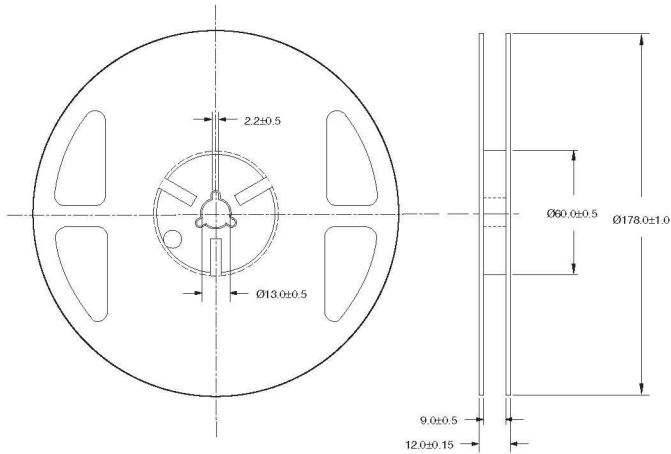

Polarity

Dimensional tolerance is ± 0.1 mm unless otherwise specified

Angle: ± 0.5

Unit: mm



SURFACE MOUNT LED LAMP

RIGHT ANGLE

Low V_F Blue

QTLP610CEBTR

DISCLAIMER

FAIRCHILD SEMICONDUCTOR RESERVES THE RIGHT TO MAKE CHANGES WITHOUT FURTHER NOTICE TO ANY PRODUCTS HEREIN TO IMPROVE RELIABILITY, FUNCTION OR DESIGN. FAIRCHILD DOES NOT ASSUME ANY LIABILITY ARISING OUT OF THE APPLICATION OR USE OF ANY PRODUCT OR CIRCUIT DESCRIBED HEREIN; NEITHER DOES IT CONVEY ANY LICENSE UNDER ITS PATENT RIGHTS, NOR THE RIGHTS OF OTHERS.

LIFE SUPPORT POLICY

FAIRCHILD'S PRODUCTS ARE NOT AUTHORIZED FOR USE AS CRITICAL COMPONENTS IN LIFE SUPPORT DEVICES OR SYSTEMS WITHOUT THE EXPRESS WRITTEN APPROVAL OF THE PRESIDENT OF FAIRCHILD SEMICONDUCTOR CORPORATION. As used herein:

1. Life support devices or systems are devices or systems which, (a) are intended for surgical implant into the body, or (b) support or sustain life, and (c) whose failure to perform when properly used in accordance with instructions for use provided in the labeling, can be reasonably expected to result in a significant injury of the user.
2. A critical component in any component of a life support device or system whose failure to perform can be reasonably expected to cause the failure of the life support device or system, or to affect its safety or effectiveness.