

SCHEMATIC  
ON - ON - DPDT ILLUMINATED

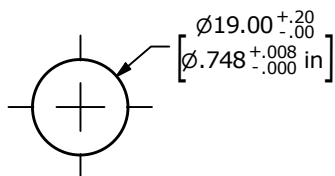

RECOMMENDED PANEL CUTOUT  
MAX. PANEL THICKNESS 10.0 [.39 in]

SWITCH	WIRE	LENGTH
SW1-1	WIRE, 18 AWG AWM UL3385, YELLOW	500.0 [19.7 in]
SW1-2	WIRE, 18 AWG AWM UL3385, PURPLE	500.0 [19.7 in]
SW1-3	WIRE, 18 AWG AWM UL3385, GREEN	500.0 [19.7 in]
SW1-4	WIRE, 18 AWG AWM UL3385, YELLOW	500.0 [19.7 in]
SW1-5	WIRE, 18 AWG AWM UL3385, PURPLE	500.0 [19.7 in]
SW1-6	WIRE, 18 AWG AWM UL3385, GREEN	500.0 [19.7 in]
SW1- (-)	WIRE, 18 AWG AWM UL3385, BLACK	500.0 [19.7 in]
SW1- (+)	WIRE, 18 AWG AWM UL3385, RED	500.0 [19.7 in]



NOTES:

1. DIMENSIONS IN MM [INCH]
2. GENERAL TOLERANCE: X.X = ±0.4  
X.XX = ±0.25
3. TERMINAL NUMBERS FOR REF ONLY
4. CONTACT MATERIAL: SILVER
5. RATING: 3A 250 VAC cUL
6. OPERATING TEMP.: -20°C to 55°C
- ▲ 7. LAMP VOLTAGE: 20mA 3V
8. TRAVEL: 3.2mm
9. ACTUATION FORCE: 5.5 ±1.0 N
10. MOUNTING NUT TORQUE: 5-14 Nm
11. INGRESS PROTECTION: IP67, IK10
12. MECHANICAL LIFE: 500,000 CYCLES.
13. ELECTRIC LIFE: 50,000 MAKE-AND-BREAK CYCLES AT FULL LOAD.
14. INSULATION RESISTANCE: 1,000 MΩ @ 500VDC MIN.
15. DIELECTRIC STRENGTH: 2,000 VAC MIN. FOR 1 MINUTE
16. CONTACT RESISTANCE: 50mΩ MAX. @ 1A 12VDC
17. ▲ DENOTES CRITICAL PARAMETER.
18. ALL MATERIAL SHALL BE ROHS COMPLIANT
- ▲ 19. SUPPLIED HARDWARE: O-RING AND HEXNUT
- ▲ 20. USE P/N's DESIGNATED OR ENGINEERING APPROVED EQUIVALENTS.

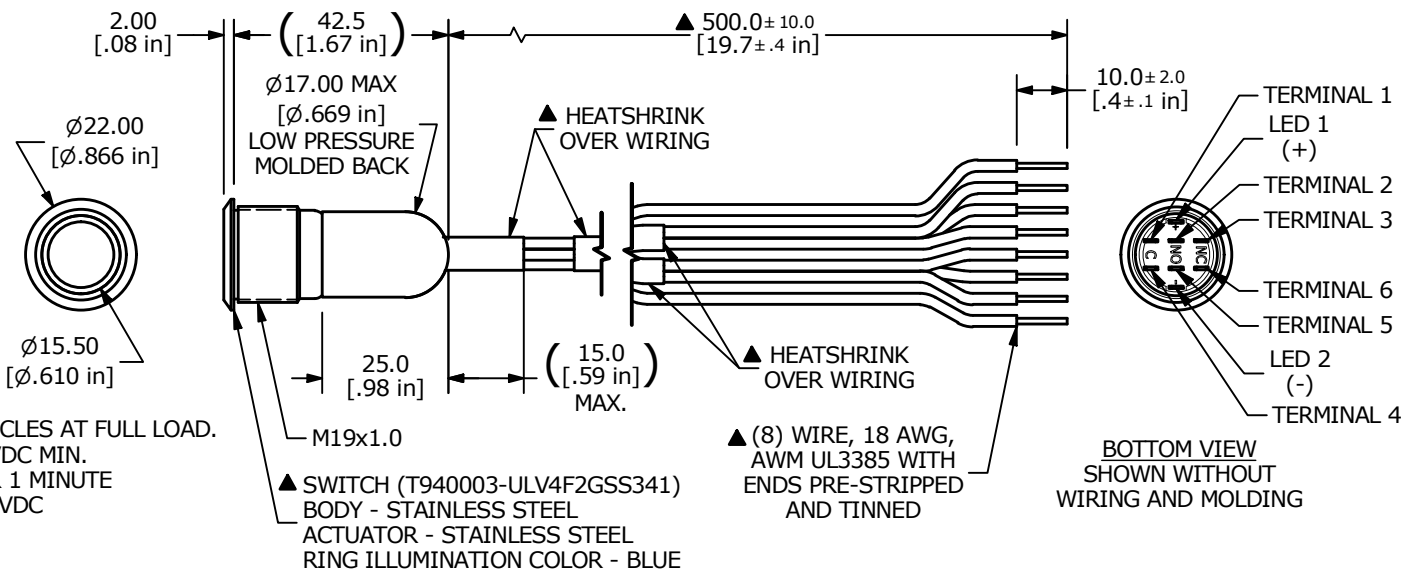

REV	ECO NO	DESCRIPTION	DATE	BY
E	ECO-100361	UPDATE PANEL CUTOUT	12/10/21	JS



OBJECT ID  
000026182

TITLE  
ULV4FMGSS341

SCALE	DATE	DR	DWG	REV
2:3	1/23/2020	MJR	T940903	E