

SWITCH	WIRE	LENGTH
SW1-1	WIRE, 24AWG AWM UL1015, BLUE	300.0 [11.8 in]
SW1-2	WIRE, 24AWG AWM UL1015, PURPLE	300.0 [11.8 in]
SW1-3	WIRE, 24AWG AWM UL1015, GREEN	300.0 [11.8 in]
SW1-4	WIRE, 24AWG AWM UL1015, WHITE	300.0 [11.8 in]
SW1-5	WIRE, 24AWG AWM UL1015, ORANGE	300.0 [11.8 in]
SW1-6	WIRE, 24AWG AWM UL1015, YELLOW	300.0 [11.8 in]
SW1- (-)	WIRE, 24AWG AWM UL1015, BLACK	300.0 [11.8 in]
SW1- (+)	WIRE, 24AWG AWM UL1015, RED	300.0 [11.8 in]

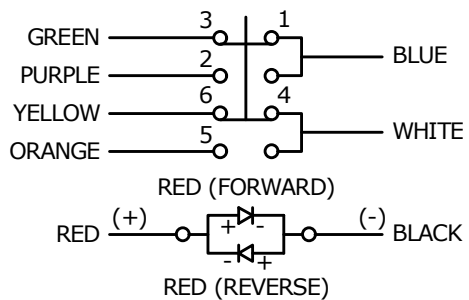

SCHEMATIC
ON - ON - DPDT ILLUMINATED

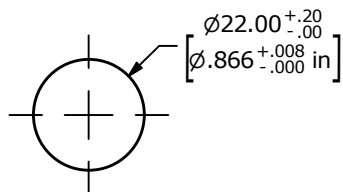

RECOMMENDED PANEL CUTOUT
MAX. PANEL THICKNESS 10.0 [.39 in]

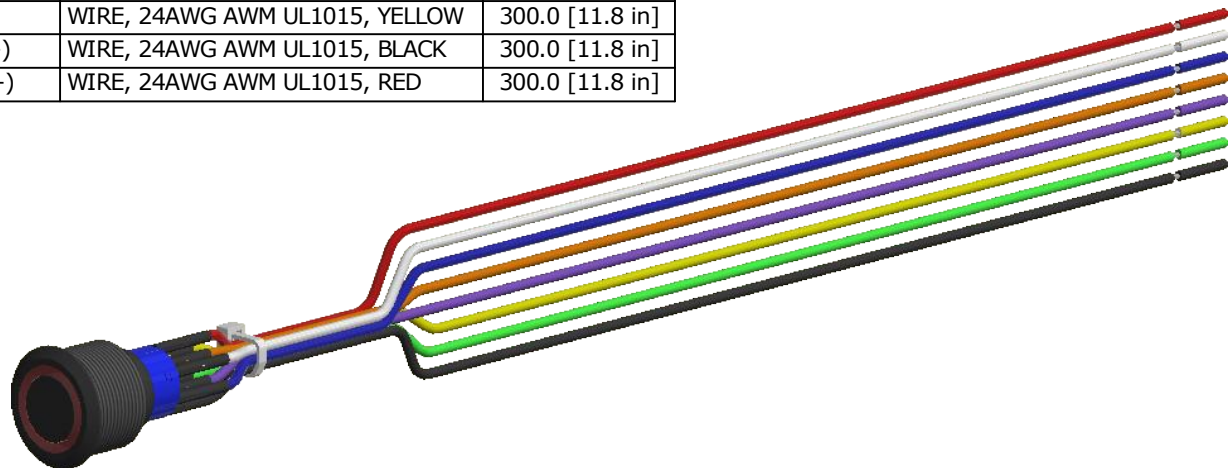

- NOTES:
1. DIMENSIONS IN MM [INCH]
 2. GENERAL TOLERANCE: X.X = ±0.4
X.XX = ±0.25
 3. TERMINAL NUMBERS FOR REF ONLY
 4. CONTACT MATERIAL: SILVER
 5. RATING: 3A 250 VAC cUL
 6. OPERATING TEMP.: -20°C to 55°C
 - ▲ 7. LAMP VOLTAGE: 20mA 3V
 8. TRAVEL: 3.2mm
 9. ACTUATION FORCE: 3.5 ±1.0 N
 10. MOUNTING NUT TORQUE: 5-14 Nm
 11. INGRESS PROTECTION: IP67
 12. MECHANICAL LIFE: 500,000 CYCLES.
 13. ELECTRIC LIFE: 50,000 MAKE-AND-BREAK CYCLES AT FULL LOAD.
 14. INSULATION RESISTANCE: 1,000 MΩ @ 500VDC MIN.
 15. DIELECTRIC STRENGTH: 2,000 VAC MIN. FOR 1 MINUTE
 16. CONTACT RESISTANCE: 50mΩ MAX. @ 1A 12VDC
 17. ▲ DENOTES CRITICAL PARAMETER.
 18. ALL MATERIAL SHALL BE ROHS COMPLIANT
 - ▲ 19. SUPPLIED HARDWARE: O-RING AND HEXNUT
 - ▲ 20. USE P/N'S DESIGNATED OR ENGINEERING APPROVED EQUIVALENTS.

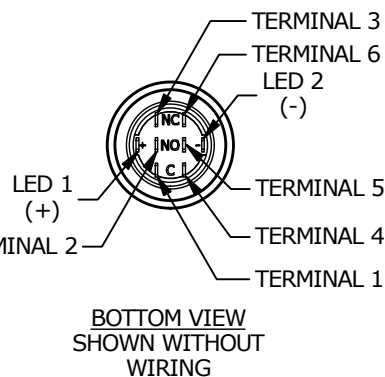
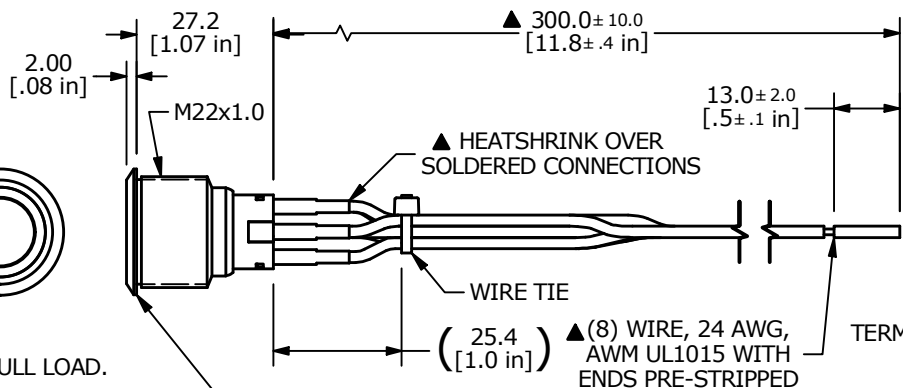
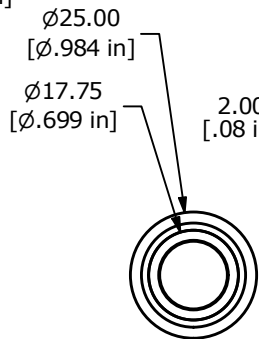

SWITCH (ULV7F2G11311)
BODY - BLACK ANODIZED
ACTUATOR - BLACK ANODIZED
RING ILLUMINATION COLOR - RED

REV	ECO NO	DESCRIPTION	DATE	BY
F	ECO-100321	UPDATE PANEL CUTOUT	09/29/21	JS



OBJECT ID
000026359

TITLE ULV7FWG11311		SCALE 2:3	DATE 1/28/2019	DR MJR	DWG T970502	REV F
-----------------------	--	--------------	-------------------	-----------	----------------	----------