

SUGGESTED PANEL CUTOUT
MAX PANEL THICKNESS 6.0mm

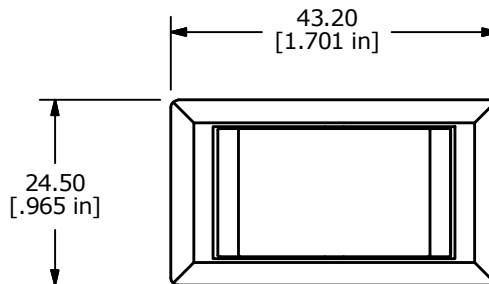

SWITCH FUNCTION		
POS. 3	POS. 2	POS. 1
ON	OFF	ON
2-1, 5-4	OPEN	2-3, 5-6

MAINTAINED

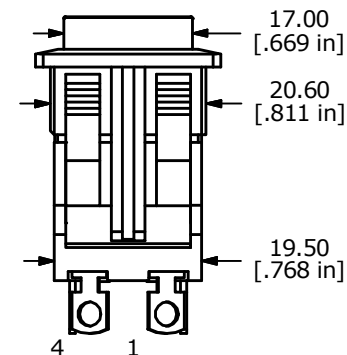
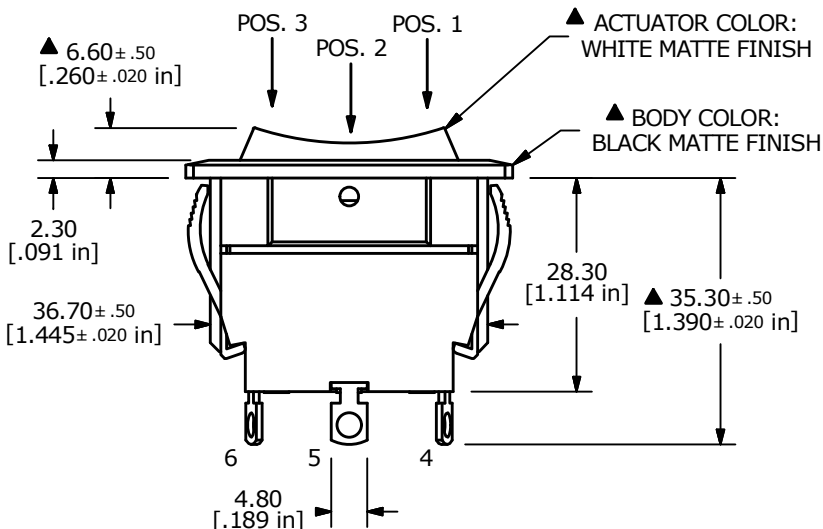
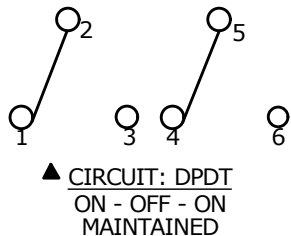

NOTES:

1. ALL DIMENSIONS IN MM [INCH]
2. GENERAL TOLERANCE: X.X ± 0.4
X.XX ± 0.25
- ▲ 3. RATINGS: ANSI/UL 508 AND CAN/CSA C22.2 NO.14 (E195908):
20A, 125VAC [cURus]
15A, 277VAC [cURus]
2HP, 110/250VAC [cURus]
4. CONTACT RESISTANCE: 50 mΩ MAX. @ 50VAC
5. INSULATION RESISTANCE: 800 MΩ MIN. @ 500VDC
6. OPERATING TEMPERATURE: 0°C TO +55°C [cURus, CSA]
0°C TO +55°C [VDE]
7. ELECTRICAL LIFE: 6,000 CYCLES [cURus]
8. DIELECTRIC STRENGTH: 1,500V FOR 1 MINUTE
10. INGRESS PROTECTION: IP54
11. ▲ DENOTES CRITICAL PARAMETER
12. 2011/65/EU (RoHS) COMPLIANT.

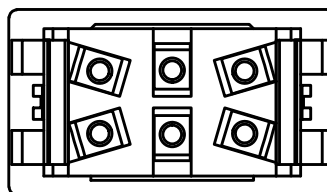

C	22504	UPDATED NOTES	5/18/17	MJR
REV	PCR NO	DESCRIPTION	DATE	BY

TITLE RVW56D1200				
SCALE 1:1	DATE 7/1/2009	DR CAB	DWG 34-RVW56D1200	REV C

THE INFORMATION CONTAINED IN THIS DOCUMENT IS PROPRIETARY TO E-SWITCH AND IS NOT TO BE COPIED OR TRANSFERRED