

Variante 1
version 1
Bestückung kraftlos
powerless assembly

Ansaughaube nur bei Version 1
hood only on version 1

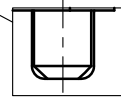

Variante 2
version 2
Bestückung mit Kraft
assembly with force

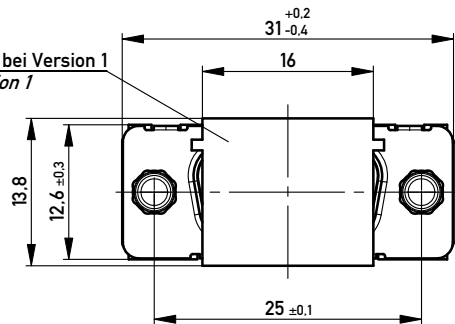
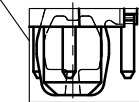

ohne / without

Mutter / nut
max. Einschraubtiefe 3,5 mm
thread depth max. 3.5 mm

Bolzen / bolt
max. Einschraubtiefe 5,5 mm
thread depth max. 5.5 mm

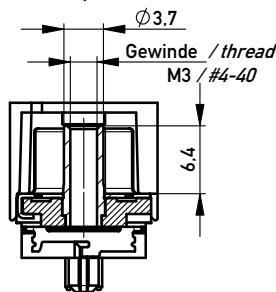
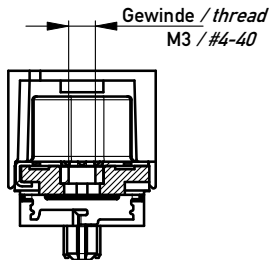
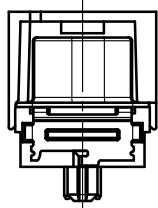

Beschriftung nach Bedruckungsvorschrift 174538
Part marking according to specification 174538

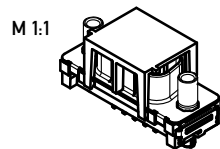

Anschlussbereich verzinkt
terminal area tin plating

Anforderungsstufe: 2
class: 2

		214563	X			
		214567			#4-40	
		214566			M3	
		214565			#4-40	
		214564			M3	
Ident.-Nr. part-no. tape & reel Variante 1 version 1	Ident.-Nr. part-no. tray Variante 1 version 1	Ident.-Nr. part-no. tray Variante 2 version 2	ohne without	Mutter thread	Bolzen bolt	Bemerkung remark

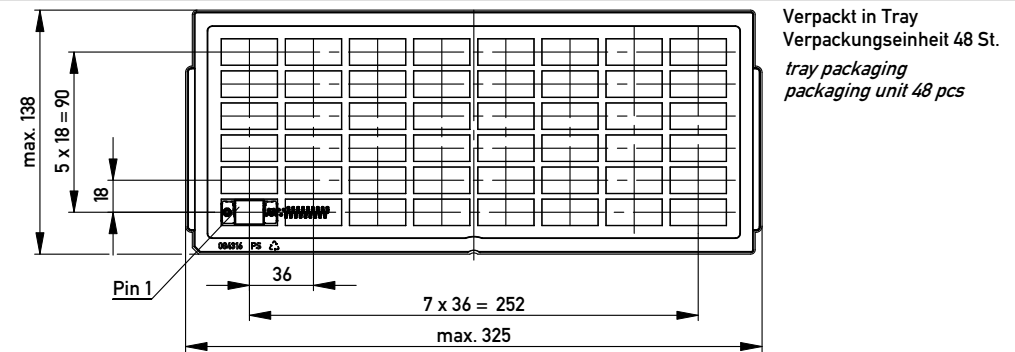

Verpackt in Tray
Verpackungseinheit 48 St.
tray packaging
packaging unit 48 pcs

Sonstige Angaben siehe Zeichnung 204628 / Additional indications according to drawing 204628

Verpackt in Gurtverpackung - Tape on Reel Packaging
Verpackungseinheit: 75 Stück - Packaging unit: 75 pcs

Abspulrichtung - Reel off Direction

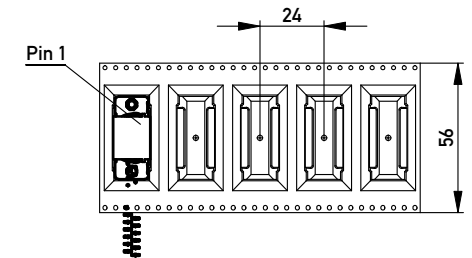
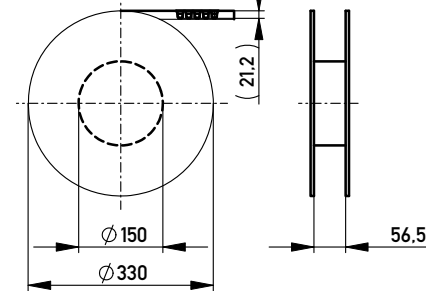

Layoutvorschlag:
recommended layout:

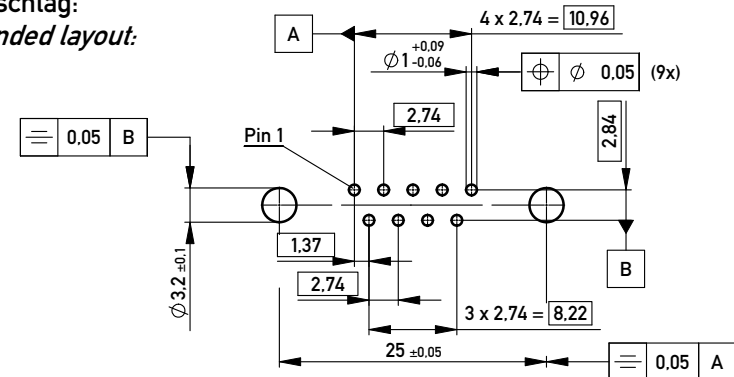

Sonstige Angaben siehe Zeichnung 204625 / Additional indications according to drawing 204625

Fehlende Masse und Angaben siehe DIN 41652 / Missing information and dimensions according to DIN 41652
Sonstige Angaben siehe Fertigungsunterlagen / Additional indications according to the production documentation

Information: All rights reserved. Only for Information. To ensure that this is the latest version of this drawing, please contact one of the ERNI companies before using.	Tolerances All Dimensions in mm	Scale 2:1
		Designation TMC-P 09-THR-3,0-6,0-BA8 TMC-P 09-THR-3,0-6,0-type 8
www.ERNI.com		144989
c	23.03.2010	
Index	Date	
Class		TMCP