

The sub miniature ECX-1637 is a very compact SMD Crystal. The 2.0 x 1.6 x 0.45 mm ceramic package is ideal for today's SMD manufacturing environment.

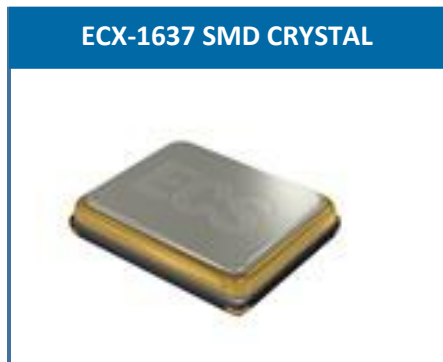

- Low Profile
- 2.0 x 1.6 mm Footprint
- Extended Temp. Range Option
- RoHS Compliant

DIMENSIONS (mm)

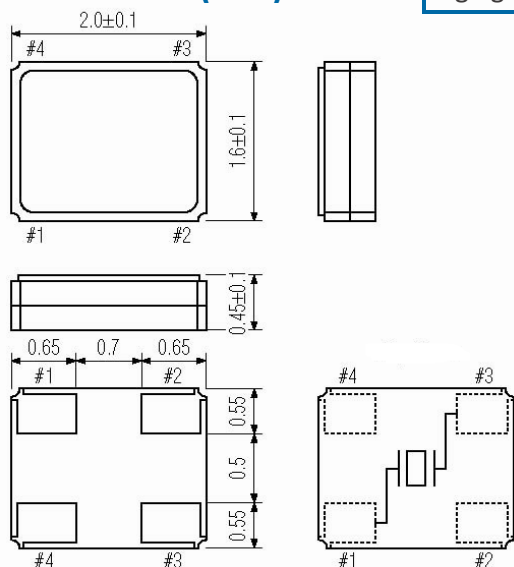

Figure 1) Top, Side, and Bottom

Crystal is symmetrical, pad 1 & 3 are interchangeable. Chamfer on the bottom pad has no electrical significance.

OPERATING CONDITIONS / ELECTRICAL CHARACTERISTICS

PARAMETERS	CONDITIONS	ECX-1637			UNITS
		MIN	TYP	MAX	
Frequency		16.000		80.000	MHz
Mode of Oscillation	Fundamental				
Frequency Tolerance*	@ +25°C			± 50	ppm
Frequency Stability*	-20 ~ +70°C			± 50	ppm
Shunt Capacitance	Co			5	pF
Load Capacitance	Specify in P/N		8		pF
Drive Level	DL			100	μW
Operating Temperature*	T _{opr}	-20		+70	°C
Storage Temperature	T _{stg}	-40		+85	°C
Aging (First Year)	@ +25°C ±3°C			±5	ppm

Frequency (MHz)	ESR Ω Max.
16.000 ~ 23.999	100
24.000 ~ 25.999	80
26.000 ~ 39.999	60
40.000 ~ 80.000	50

Pad Connections	
1	In/Out
2	Gnd
3	Out/In
4	Gnd

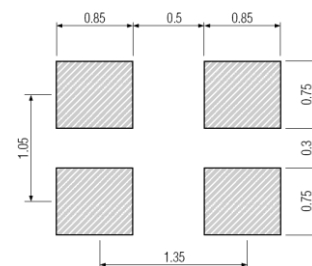

Figure 2) Suggested land

PART NUMBERING GUIDE: Example ECS-240-8-37-TR

ECS - FREQUENCY ABBREVIATION	LOAD CAPACITANCE	PACKAGE	AVAILABLE OPTIONS			PACKAGING	
			Tolerance	Stability	Temp Range		
ECS	240 = 24.000 MHz See P/N Guide	8 = 8 pF 10 = 10 pF S=Series	-37 = ECX-1637	Blank = Std A = ± 25 ppm J = ± 20 ppm R = ± 15 ppm C = ± 10 ppm	Blank = Std D = ± 100 ppm E = ± 50 ppm G = ± 30 ppm H = ± 25 ppm T = ± 20 ppm † W = ± 15 ppm † K = ± 10 ppm †	Blank = Std L = -10 ~ +70°C M = -20 ~ +70°C Y = -30 ~ +85°C N = -40 ~ +85°C P = -40 ~ +105°C S = -40 ~ +125°C U = -55 ~ +125°C	TR = Tape & Reel 1K/Reel

* Specify available options in P/N.

† Contact ECS for availability over extended temp range.

Rev.2017

POCKET TAPE DIMENSIONS (mm)

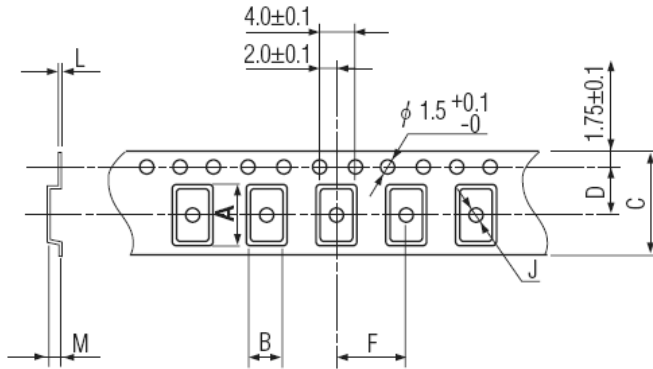

A	B	C	D	F	J	L	M	Reel Dia.	Qty/Reel
2.25	1.85	8.0	3.5	4.0	1.0	0.25	0.65	180	1000

SOLDER PROFILE	
Peak solder Temp +260°C Max 10 sec Max.	
2 Cycles Max.	
MSL 1, Lead Finish Au	

DEVELOPED FREQUENCIES	
Abbreviation	Frequency (MHZ)
160	16.000
200	20.000
240	24.000
260	26.000
270	27.000
300	30.000
320	32.000
360	36.000
400	40.000

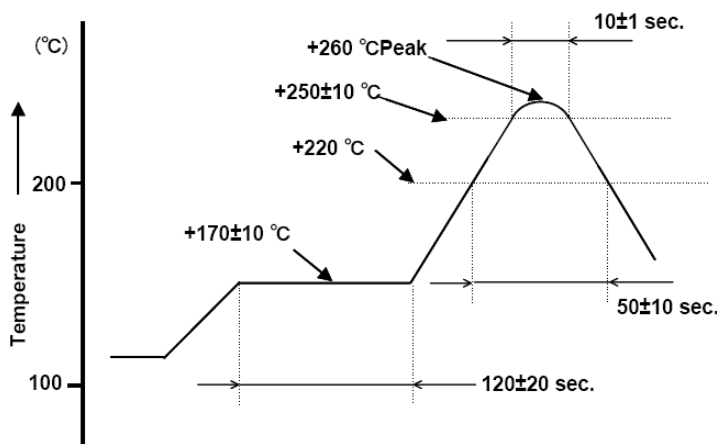

Figure 1) Suggested Reflow Profile