

Product Change Notice

Date:	February 26, 2020
Overview:	Change to the shrink tubing procedure for (7) AC blowers – instead of shrinking the entire length of the tubing, going forward only a portion of the tubing will be shrunk
Reason for Change:	In rare cases, shrinking the tubing over the entire length of the wires may exert enough pressure on the wire insulation to pull back slightly from the brass-lead tip ends, leaving a small area of exposed wires at the lead wire ends. By not shrinking the tubing at the end of the lead wires it will eliminate this potential scenario that may occur on our production line.
Affected Part No(s):	<ul style="list-style-type: none"> - G2E180-EH03-17 - R2E250-RB06-12 - R2E250-RB06-19 - R2E250-RB06-33 - R2E250-RC08-16 - R4E310-AO12-14 - R4E310-AO32-13
Design Change Detail:	<p>Currently the tubing is heat-shrunk for the entire length of the cable.</p> <p>Moving forward the tubing will be heat-shrunk for only about a 60 mm distance from the stator / motor, after which the tubing will remain loose.</p>
Effective Date:	Effective immediately with new factory orders / new production runs. Some inventory may still be available with the current design and may continue to be shipped prior to the new design implementation.
Last Time Buy Deadline:	N/A
Pricing:	No change

ebm-papst employee:	Jeannine Zenobi
Attachments:	Drawing showing current vs new shrink tubing procedure
Comments:	N/A

Form No: 1274	Quality Record - No	Page 1 of 1
Rev. – Orig, Released 08/28/14	Retention Period – 1 year	Dept. Owner – Sales/Marketing

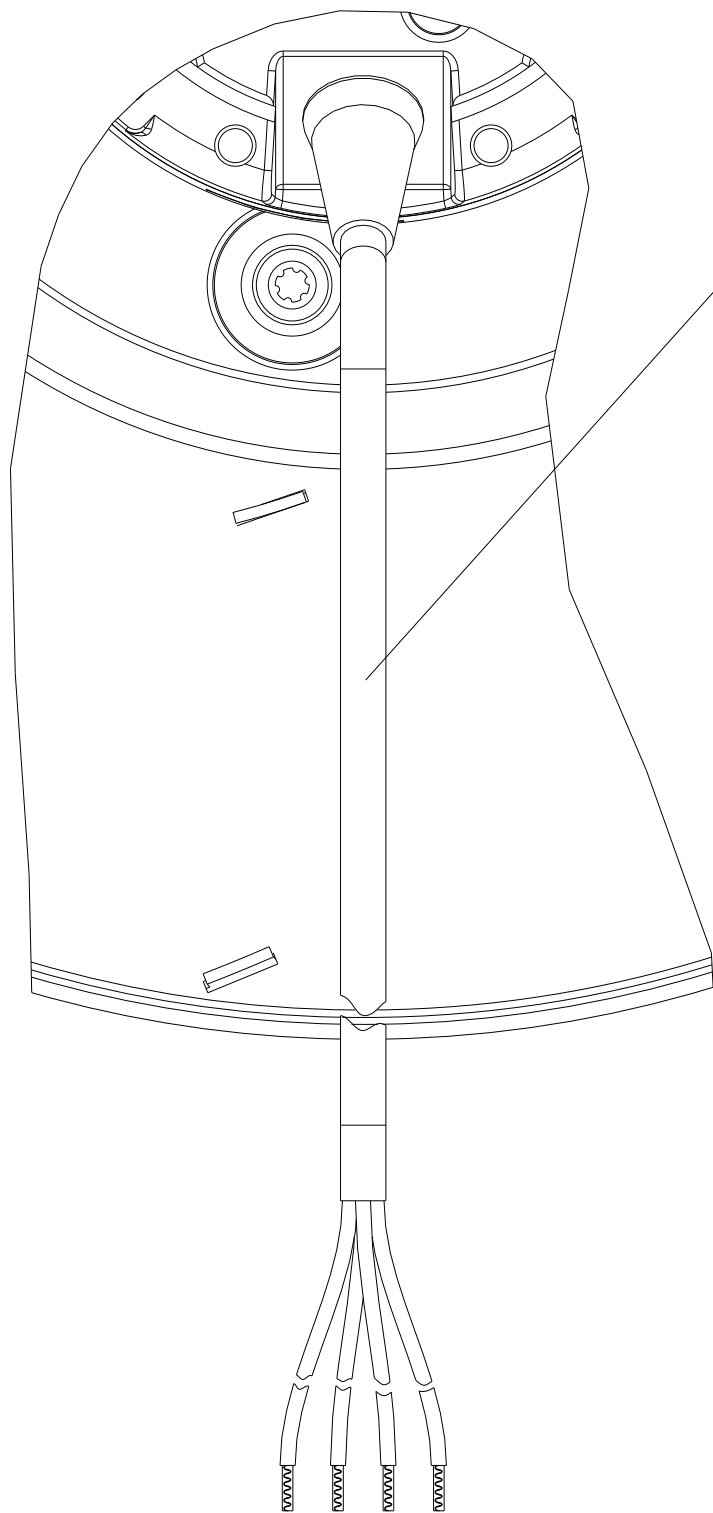

bisherige Ausführung:
Schrumpfschlauch komplett
geschrumpft
*existing design:
shrink-sleeve completely shrunk*

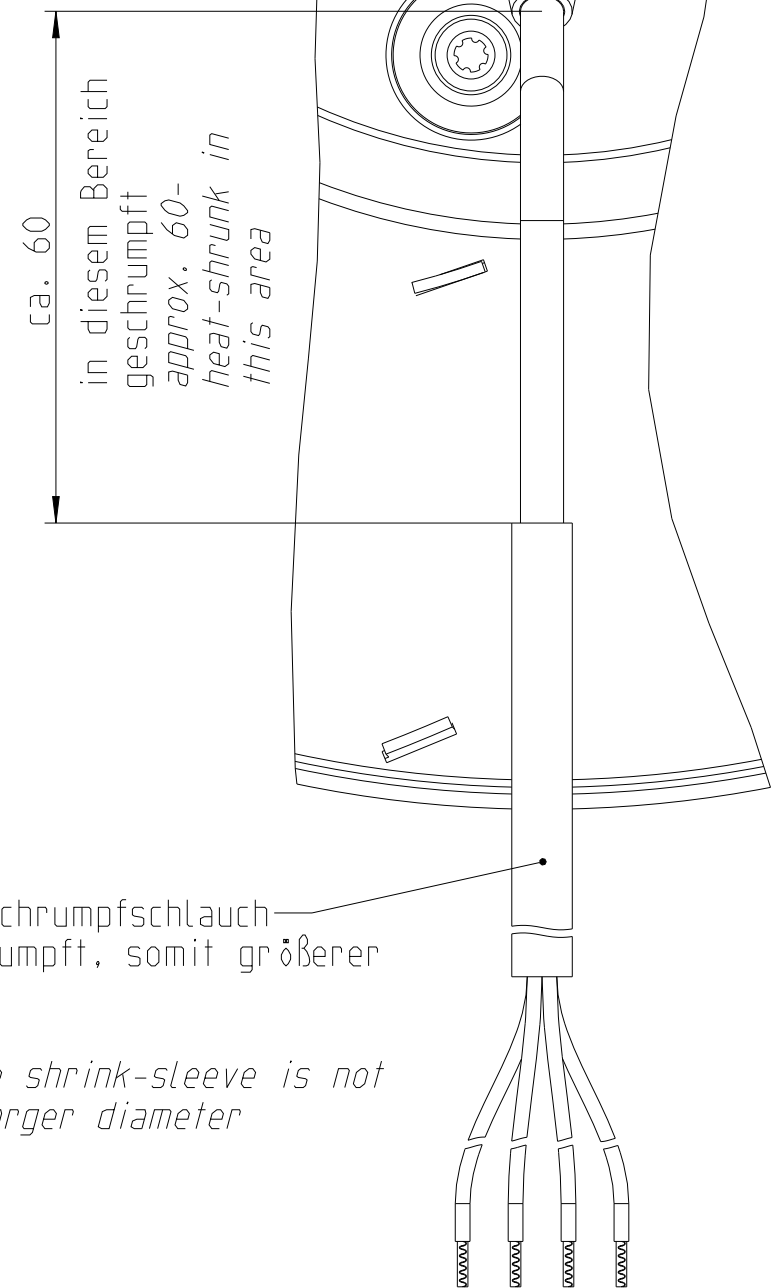

der restliche Schrumpfschlauch
bleibt ungeschrumpft, somit größerer
Durchmesser
*new design:
the rest of the shrink-sleeve is not
shrunk, thus larger diameter*

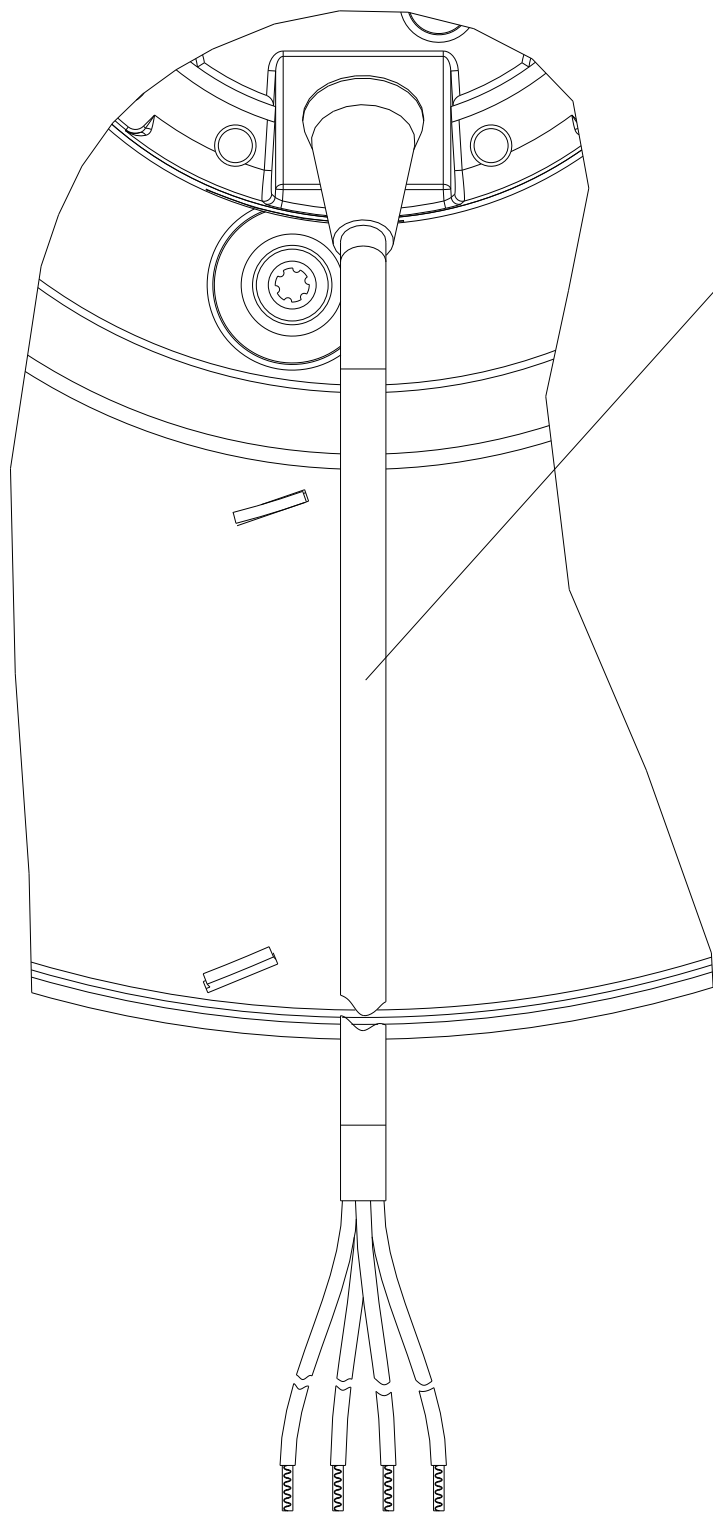

bisherige Ausführung:
Schrumpfschlauch komplett
geschrumpft
*existing design:
shrink-sleeve completely shrunk*

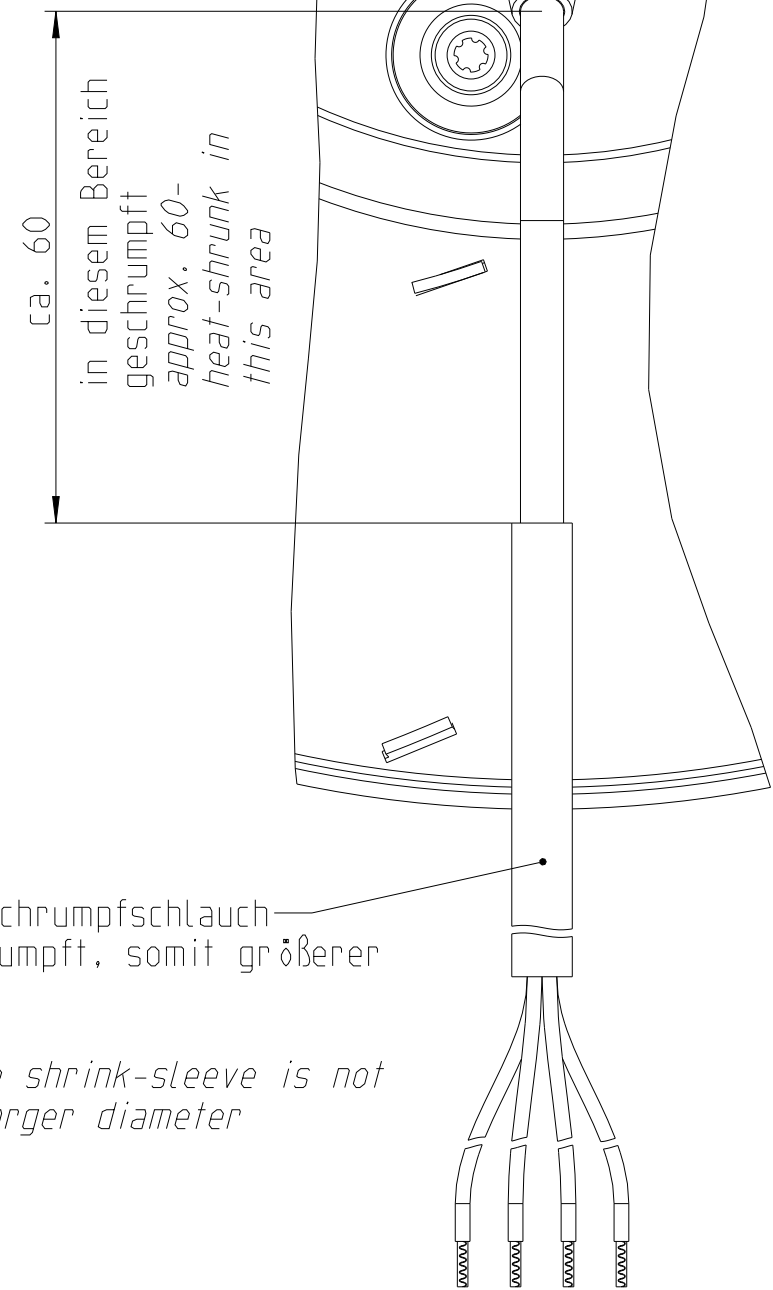

ca. 60
in diesem Bereich
geschrumpft
*approx. 60-
heat-shrunk in
this area*

der restliche Schrumpfschlauch
bleibt ungeschrumpft, somit größerer
Durchmesser
*new design:
the rest of the shrink-sleeve is not
shrunk, thus larger diameter*