

The documentation and process conversion Measures necessary to comply with this revision shall be completed by 16 April 2012.

INCH-POUND

MIL-PRF-19500/511H
w/AMENDMENT 2
2 March 2012
SUPERSEDING
MIL-PRF-19500/511H
w/AMENDMENT 1
6 August 2011

PERFORMANCE SPECIFICATION SHEET

* SEMICONDUCTOR DEVICE, TRANSISTOR, PNP, SILICON, SWITCHING
TYPE 2N4261, 2N4261UB, 2N4261UBC JAN, JANTX, JANTXV AND JANS, JANHC AND JANKC, JANTXVM, JANTXVD, JANTXVP, JANTXVL, JANTXVR, JANTXVF, JANTXVG, JANTXVH, JANSM, JANSJ, JANSK, JANSL, JANSR, JANSF, JANSJ, JANSH, JANHCM, JANHCD, JANHCP, JANHCL, JANHCR, JANHCF, JANHCG, JANHCH, JANKCM, JANKCD, JANKCP, JANKCL, JANKCR, JANKCF, JANKCG, AND JANKCH

This specification is approved for use by all Departments and Agencies of the Department of Defense.

The requirements for acquiring the product described herein shall consist of this specification sheet and MIL-PRF-19500.

1. SCOPE

* 1.1 Scope. This specification covers the performance requirements for PNP silicon, switching transistors. Four levels of product assurance are provided for each encapsulated device type. Two levels for unencapsulated die as specified in MIL-PRF-19500. RHA level designators "M", "D", "P", "L", "R", "F", "G", and "H" are appended to the device prefix to identify devices which have passed RHA requirements.

1.2 Physical dimensions. See figure 1 (TO-72), figure 2 and 3 (UB and UBC), and figure 4 (JANHC, JANKC).

1.3 Maximum ratings. Unless otherwise specified, $T_A = +25^\circ\text{C}$.

P_T $T_A = +25^\circ\text{C}$ (1)	$R_{\theta JA}$	V_{CBO}	V_{CEO}	V_{EBO}	I_C	T_J	T_J and T_{STG}
<u>mW</u>	<u>$^\circ\text{C}/\text{mW}$</u>	<u>V dc</u>	<u>V dc</u>	<u>V dc</u>	<u>mA dc</u>	<u>$^\circ\text{C}$</u>	<u>$^\circ\text{C}$</u>
200	0.860	15	15	4.5	30	200	-65 to +200

(1) Derate linearly 1.14 mW/ $^\circ\text{C}$ above $T_A = +25^\circ\text{C}$.

Comments, suggestions, or questions on this document should be addressed to DLA Land and Maritime, ATTN: VAC, P.O. Box 3990, Columbus, OH 43218-3990, or emailed to Semiconductor@dsc.dla.mil. Since contact information can change, you may want to verify the currency of this address information using the ASSIST Online database at <https://assist.daps.dla.mil/>.

MIL-PRF-19500/511H
w/AMENDMENT 2

1.4 Primary electrical characteristics. Unless otherwise specified, $T_A = +25^\circ\text{C}$.

	h_{FE1} (1)	h_{FE2} (1)	h_{FE3} (1)	$ h_{fe2} $	$r_b' C_C$	Switching	
	$V_{CE} = 1.0 \text{ V dc}$ $I_C = 1 \text{ mA dc}$	$V_{CE} = 1.0 \text{ V dc}$ $I_C = 10 \text{ mA dc}$	$V_{CE} = 1.0 \text{ V dc}$ $I_C = 30 \text{ mA dc}$	$V_{CE} = 10 \text{ V dc}$ $I_C = 10 \text{ mA dc}$ $f = 100 \text{ MHz}$	$V_{CE} = 4.0 \text{ V dc}$ $I_C = 5 \text{ mA dc}$ $f = 31.8 \text{ MHz}$	t_{on}	t_{off}
Min Max	25	30 150	20	20	<u>ps</u> 60	<u>ns</u> 2.5	<u>ns</u> 3.5

	$V_{CE(sat)1}$ $I_C = 1 \text{ mA dc}$ $I_B = 0.1 \text{ mA dc}$	$V_{CE(sat)2}$ $I_C = 10 \text{ mA dc}$ $I_B = 1.0 \text{ mA dc}$	V_{BE1} $I_C = 1 \text{ mA dc}$ $V_{CE} = 1 \text{ V dc}$	V_{BE2} $I_C = 10 \text{ mA dc}$ $V_{CE} = 1 \text{ V dc}$	C_{obo} $V_{CB} = 4 \text{ V dc}$ $I_E = 0$ $100 \text{ kHz} \leq f \leq 1 \text{ MHz}$
Min Max	<u>V dc</u> 0.15	<u>V dc</u> 0.35	<u>V dc</u> 0.8	<u>V dc</u> 1.0	<u>PF</u> 2.5

(1) Pulsed (see 4.5.1).

2. APPLICABLE DOCUMENTS

2.1 General. The documents listed in this section are specified in sections 3, 4, or 5 of this specification. This section does not include documents cited in other sections of this specification or recommended for additional information or as examples. While every effort has been made to ensure the completeness of this list, document users are cautioned that they must meet all specified requirements of documents cited in sections 3, 4, or 5 of this specification, whether or not they are listed.

2.2 Government documents.

2.2.1 Specifications, standards, and handbooks. The following specifications, standards, and handbooks form a part of this document to the extent specified herein. Unless otherwise specified, the issues of these documents are those cited in the solicitation or contract.

DEPARTMENT OF DEFENSE SPECIFICATIONS

MIL-PRF-19500 - Semiconductor Devices, General Specification for.

DEPARTMENT OF DEFENSE STANDARDS

MIL-STD-750 - Test Methods for Semiconductor Devices.

(Copies of these documents are available online at <https://assist.daps.dla.mil/quicksearch/> or <https://assist.daps.dla.mil/> or from the Standardization Document Order Desk, 700 Robbins Avenue, Building 4D, Philadelphia, PA 19111-5094.)

2.3 Order of precedence. Unless otherwise noted herein or in the contract, in the event of a conflict between the text of this document and the references cited herein, the text of this document takes precedence. Nothing in this document, however, supersedes applicable laws and regulations unless a specific exemption has been obtained.

MIL-PRF-19500/511H
w/AMENDMENT 2

3. REQUIREMENTS

3.1 General. The individual item requirements shall be as specified in MIL-PRF-19500 and as modified herein.

3.2 Qualification. Devices furnished under this specification shall be products that are manufactured by a manufacturer authorized by the qualifying activity for listing on the applicable qualified manufacturer's list (QML) before contract award (see 4.2 and 6.3).

3.3 Abbreviations, symbols, and definitions. The abbreviations, symbols, and definitions used herein are defined in MIL-PRF-19500 and as follows:

- g_s..... Noise source conductance.
- P_o..... Oscillator, power output.
- R_{BE} External resistance, base to emitter.
- UB and UBC..... Surface mount case outlines (see figures 2 and 3).

3.4 Interface and physical dimensions. The interface and physical dimensions shall be as specified in MIL-PRF-19500 and figure 1 (TO-72), figure 2 and 3 (UB and UBC), and figure 4 (JANHHC and JANKC) herein.

3.4.1 Lead finish. Lead finish shall be solderable in accordance with MIL-PRF-19500, MIL-STD-750, and herein. Where a choice of lead finish is desired, it shall be specified in the contract or purchase order (see 6.2).

3.5 Electrical performance characteristics. Unless otherwise specified herein, the electrical performance characteristics are as specified in 1.3, 1.4, and table I herein.

* 3.5.1 Radiation hardness assurance (RHA). Radiation hardness assurance requirements, PIN designators, and test levels shall be as defined in MIL-PRF-19500.

3.6 Electrical test requirements. The electrical test requirements shall be as specified in table I.

* 3.7 Marking. Marking shall be in accordance with MIL-PRF-19500. At the option of the manufacturer, marking may be omitted from the body of the UB and UBC package, but shall be retained on the initial container. The radiation hardened designator M, D, P, L, R, F, G, or H shall immediately precede (or replace) the device "2N" identifier (depending upon degree of abbreviation required).

3.8 Workmanship. Semiconductor devices shall be processed in such a manner as to be uniform in quality and shall be free from other defects that will affect life, serviceability, or appearance.



MIL-PRF-19500/511H
w/AMENDMENT 2

Symbol	Dimensions				Notes
	Inches		Millimeters		
	Min	Max	Min	Max	
CD	.178	.195	4.52	4.95	5
CH	.170	.210	4.32	5.33	
HD	.209	.230	5.31	5.84	5
LC	.100 TP		2.54 TP		7, 8
LD	.016	.021	.406	.533	7, 8
LL	.500	.750	12.70	19.05	7, 8
LU	.016	.019	.41	.48	
L ₁		.050		1.27	
L ₂	.250		6.35		
P	.100		2.54		
Q		.040		1.02	5
TL	.028	.048	.71	1.22	
TW	.036	.046	.91	1.17	
R		.007		.18	
α	45° TP				

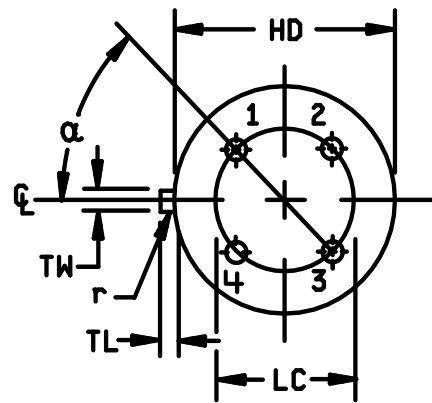
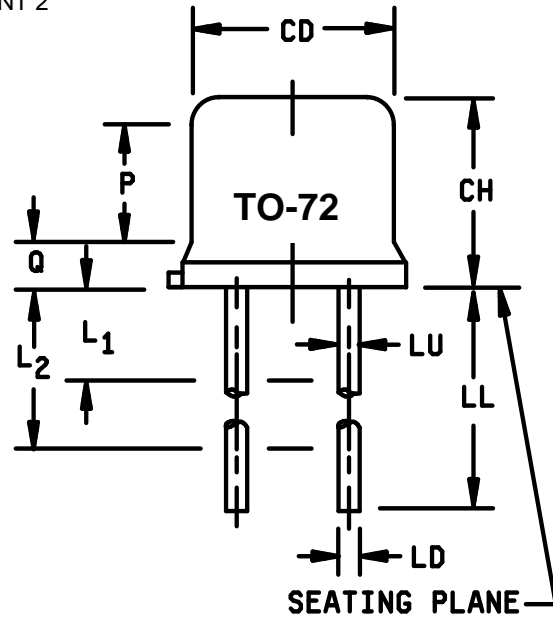

NOTES:

1. Dimension are in inches.
2. Millimeters are given for general information only.
3. Beyond r (radius) maximum, TH shall be held for a minimum length of .011 (0.28 mm).
4. Dimension TL measured from maximum HD.
5. Body contour optional within zone defined by HD, CD, and Q.
6. Leads at gauge plane $.054 +.001 -.000$ inch ($1.37 +0.03 -0.00$ mm) below seating plane shall be within $.007$ inch (0.18mm) radius of true position (TP) at maximum material condition (MMC) relative to tab at MMC.
7. Dimension LU applies between L₁ and L₂. Dimension LD applies between L₂ and LL minimum. Diameter is uncontrolled in L₁ and beyond LL minimum.
8. All four leads.
9. Dimension r (radius) applies to both inside corners of tab.
10. In accordance with ASME Y14.5M, diameters are equivalent to ϕx symbology.
11. Lead 1 = emitter, lead 2 = base, lead 3 = collector, lead 4 = case (electrically connected).

FIGURE 1. Physical dimensions for 2N4261 (TO-72).

MIL-PRF-19500/511H
w/AMENDMENT 2

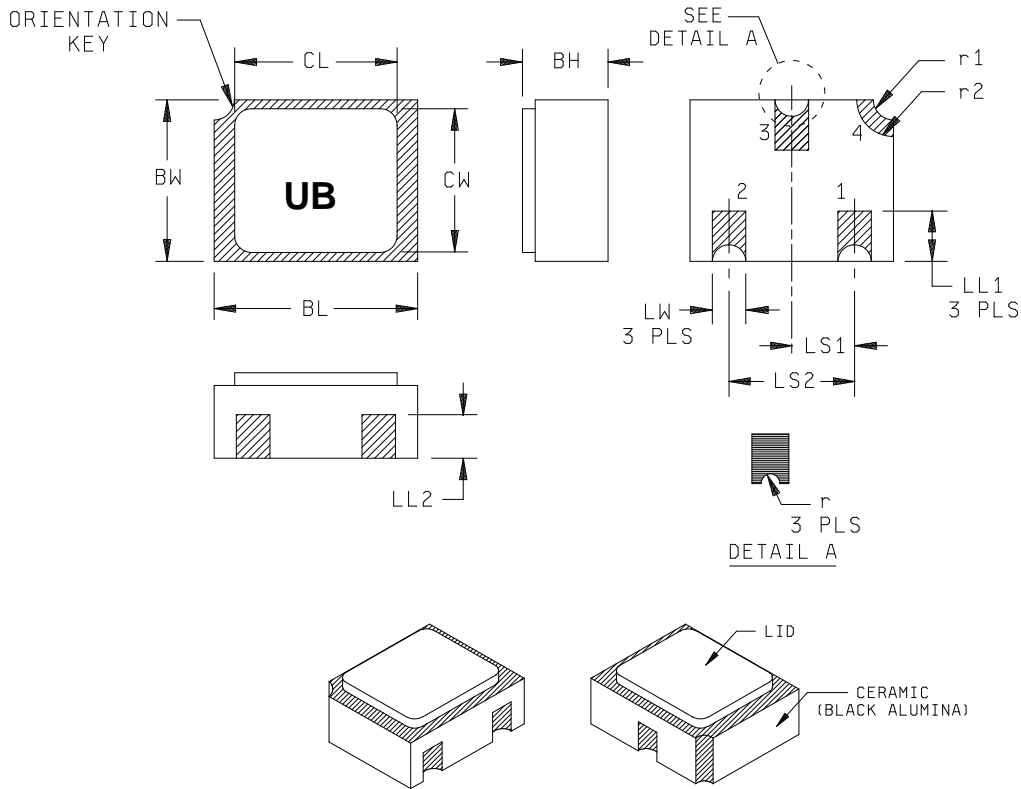

Ltr.	Dimensions				Note	Ltr.	Dimensions				Note
	Inches		Millimeters				Inches		Millimeters		
	Min	Max	Min	Max			Min	Max	Min	Max	
BH	.046	.056	1.17	1.42		LS1	.035	.040	0.89	1.02	
BL	.115	.128	2.92	3.25		LS2	.071	.079	1.80	2.01	
BW	.085	.108	2.16	2.74		LW	.016	.024	0.41	0.61	
CL		.128		3.25		r		.008		0.20	
CW		.108		2.74		r1		.012		0.31	
LL1	.022	.038	0.56	0.96		r2		.022		0.56	
LL2	.017	.035	0.43	0.89							

NOTES:

1. Dimensions are in inches.
2. Millimeters are given for general information only.
3. Hatched areas on package denote metallized areas.
4. Pad 1 = Base, Pad 2 = Emitter, Pad 3 = Collector, Pad 4 = Shielding connected to the lid.
5. In accordance with ASME Y14.5M, diameters are equivalent to ϕ x symbology.

FIGURE 2. Physical dimensions for 2N4261UB, surface mount.

MIL-PRF-19500/511H
w/AMENDMENT 2

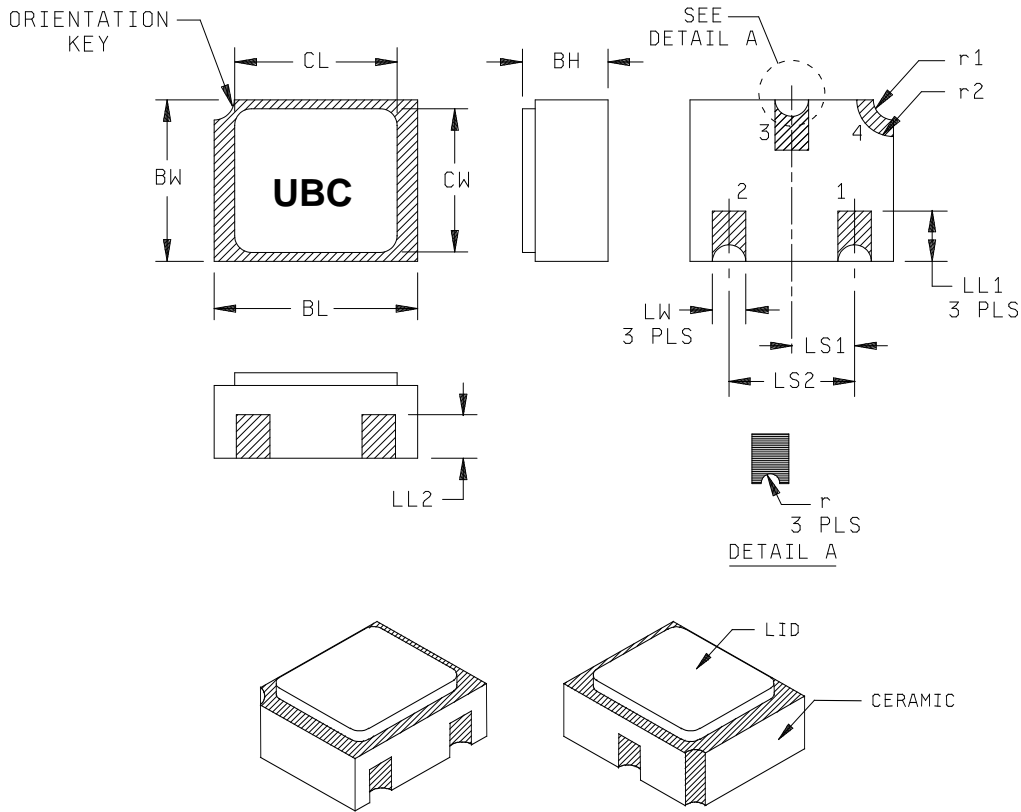

Symbol	Dimensions				Note
	Inches		Millimeters		
	Min	Max	Min	Max	
BH	.046	.071	1.17	1.80	
BL	.115	.128	2.92	3.25	
BW	.085	.108	2.16	2.74	
CL		.128		3.25	
CW		.108		2.74	
LL1	.022	.038	0.56	0.96	
LL2	.017	.035	0.43	0.89	

Symbol	Dimensions				Note
	Inches		Millimeters		
	Min	Max	Min	Max	
LS ₁	.036	.040	0.91	1.02	
LS ₂	.071	.079	1.81	2.01	
LW	.016	.024	0.41	0.61	
r		.008		.203	
r1		.012		.305	
r2		.022		.559	

NOTES:

1. Dimensions are in inches.
2. Millimeters are given for general information only.
3. Hatched areas on package denote metallized areas.
4. Pad 1 = Base, Pad 2 = Emitter, Pad 3 = Collector, Pad 4 = connected to the lid braze ring.
5. In accordance with ASME Y14.5M, diameters are equivalent to ϕx symbology.

FIGURE 3. Physical dimensions, surface mount (UBC version, ceramic lid).

MIL-PRF-19500/511H
w/AMENDMENT 2

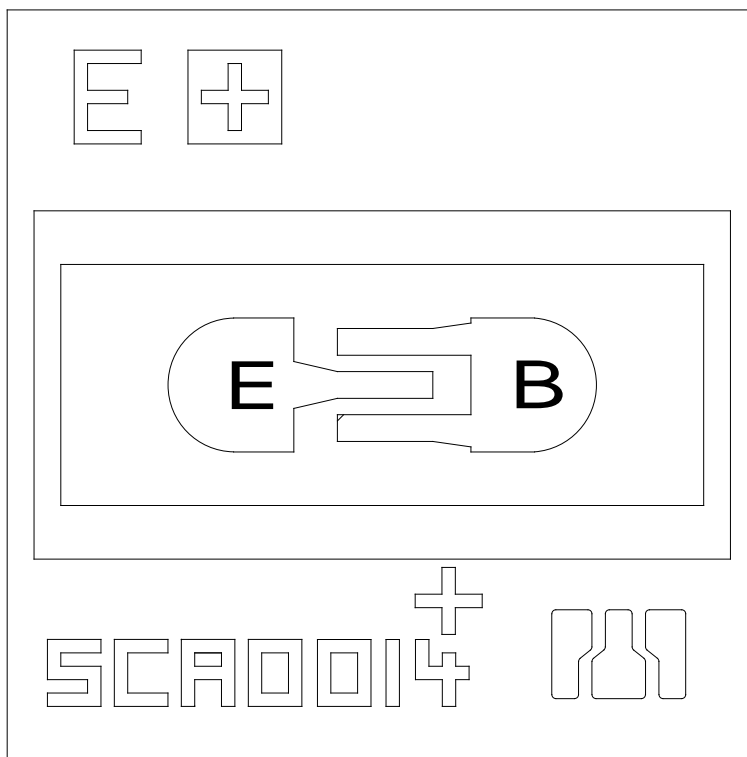

NOTES:

1. Die size016 x .016 inch (0.406 mm x 0.406mm).
2. Die thickness..... .008 ±.0016 inch (0.203 mm ±0.041mm).
3. Base pad..... .0021 x.0021 inch (0.053 mm x 0.053 mm).
4. Back metal Gold, 6,500 ±1,950 Ang.
5. Backside..... Collector
6. Emitter pad..... .0021 x.0021 inch (0.053 mm x 0.053 mm).
7. Top metal Aluminum, 14,500 ±2,500 Ang.
8. Back side..... Collector.
9. Glassivation..... SiO₂, 7,500 ±1,500 Ang.

FIGURE 4. JANHC and JANKC (A-version) die dimensions.

4. VERIFICATION

- * 4.1 Classification of inspections. The inspection requirements specified herein are classified as follows:
 - a. Qualification inspection (see 4.2).
 - b. Screening (see 4.3).
- * c. Conformance inspection (see 4.4 and tables I, II and III).

4.2 Qualification inspection. Qualification inspection shall be in accordance with MIL-PRF-19500 and as specified herein.

4.2.1 JANHC and JANKC qualification. JANHC and JANKC qualification inspection shall be in accordance with MIL-PRF-19500.

* 4.2.2 Group E qualification. Group E inspection shall be performed for qualification or re-qualification only. In case qualification was awarded to a prior revision of the specification sheet that did not request the performance of table III tests, the tests specified in table III herein that were not performed in the prior revision shall be performed on the first inspection lot of this revision to maintain qualification.

4.2.2.1 Group E thermal response. With extremely small junction devices such as this one, a true thermal impedance cannot be measured, only calculated. While "thermal response" has been substituted for "thermal impedance" herein, the terms, units and procedure as essentially unchanged. Each supplier shall submit a thermal response ($Z_{\theta JX}$) histogram of the entire qualification lot. The histogram data shall be taken prior to the removal of devices that are atypical for thermal response. Thermal response curves (from $Z_{\theta JX}$ test pulse time to $R_{\theta JX}$ minimum steady-state time) of the best device in the qual lot and the worst device in the qual lot (that meets the supplier proposed screening limit), or from the thermal grouping, shall be submitted. The optimal test conditions and proposed initial thermal response screening limit shall be provided in the qualification report. Data indicating how the optimal test conditions were derived for $Z_{\theta JX}$ shall also be submitted. The proposed maximum thermal response $Z_{\theta JX}$ screening limit shall be submitted. The qualifying activity may approve a different $Z_{\theta JX}$ limit for conformance inspection end-point measurements as applicable. Equivalent data, procedures, or statistical process control plans may be used for part, or all, of the above requirements. The approved thermal response conditions and limit for $Z_{\theta JX}$ shall be used by the supplier in screening and table I, subgroup 2. The approved thermal resistance conditions for $R_{\theta JX}$ shall be used by the supplier for conformance inspection. For product families with similar thermal characteristics based on the same physical and thermal die, package, and construction combination (thermal grouping), the supplier may use the same thermal response curves.

MIL-PRF-19500/511H
w/AMENDMENT 2

4.3 Screening (JANS, JANTX, and JANTXV levels only). Screening shall be in accordance with table E-IV of MIL-PRF-19500 and as specified herein. The following measurements shall be made in accordance with table I herein. Devices that exceed the limits of table I herein shall not be acceptable.

Screen (see table E-IV of MIL-PRF-19500)	Measurements	
	JANS	JANTX, JANTXV levels
(1) 3c	Thermal impedance, method 3131 of MIL-STD-750 (see 4.3.2).	Thermal impedance, method 3131 of MIL-STD-750 (see 4.3.2).
9	I_{CEX2} and h_{FE2} .	Not applicable.
11	I_{CEX2} and h_{FE2} ; ΔI_{CEX2} = 100 percent of initial value or 1 nA dc, whichever is greater. Δh_{FE2} = ± 15 percent of initial value.	I_{CEX2} and h_{FE2} .
12	See 4.3.3.	See 4.3.3, 80 hours min.
13	Subgroup 2 and 3 of table I herein; ΔI_{CEX2} = 100 percent of initial value or 1 nA dc, whichever is greater. Δh_{FE2} = ± 25 percent of initial value.	Subgroup 2 of table I herein; ΔI_{CEX2} = 100 percent of initial value or 2 nA dc, whichever is greater. Δh_{FE2} = ± 25 percent of initial value.

(1) Shall be performed anytime after temperature cycling, screen 3a; TX and TXV do not need to be repeated in screening requirements.

4.3.1 Screening (JANHNC and JANKC). Screening of JANHNC and JANKC die shall be in accordance with MIL-PRF-19500, "Discrete Semiconductor Die/Chip Lot Acceptance". Burn-in duration for the JANKC level follows JANS requirements; the JANHNC follows JANTX requirements.

4.3.2 Thermal impedance (ΔV_{BE} measurements). The ΔV_{BE} measurements shall be performed in accordance with method 3131 of MIL-STD-750 using the guidelines in that method for determining V_H , V_{CE} , I_M , I_H , t_H , and t_{MD} . The ΔV_{BE} limit used in screen 3c and table I, subgroup 2 shall be set statistically by the supplier over several die lots and submitted to the qualifying activity for approval.

4.3.3 Power burn-in conditions. Power burn-in conditions are as follows: T_A = room ambient in accordance with the general requirements of MIL-STD-750 (see 4.5). V_{CB} = 10 V dc, P_T = 200 mW.

4.4 Conformance inspection. Conformance inspection shall be in accordance with MIL-PRF-19500, and as specified herein.

4.4.1 Group A inspection. Group A inspection shall be conducted in accordance with MIL-PRF-19500, and table I herein. Electrical measurements (end-points) shall be in accordance with table I herein.

4.4.2 Group B inspection. Group B inspection shall be conducted in accordance with the tests and conditions specified for subgroup testing in table E-VIa (JANS) of MIL-PRF-19500 and 4.4.2.1. Electrical measurements (end-points) shall be in accordance with table I, subgroup 2. See 4.4.2.2 for JAN, JANTX, and JANTXV group B testing. Electrical measurements (end-points) for JAN, JANTX, and JANTXV shall be after each step in 4.4.2.2 and shall be in accordance with table I, subgroup 2 herein.

MIL-PRF-19500/511H
w/AMENDMENT 2

4.4.2.1 Group B inspection, table E-VIa (JANS) of MIL-PRF-19500.

<u>Subgroup</u>	<u>Method</u>	<u>Condition</u>
B4	1037	$V_{CB} = 10$ V dc, 2,000 cycles, $t_{ON} = t_{OFF} = 3$ minutes, $P_{D(ON)} = P_D$ max rated in accordance with 1.3; $P_{D(OFF)} = 0$.
B5	1027	$V_{CB} = 10$ V dc, $t = 1,000$ hours minimum. $P_D =$ maximum rated P_T (see 1.3), $T_J = +150^\circ\text{C}$ minimum, in addition, adjust T_A to achieve T_J . $n = 45$, $c = 0$.

4.4.2.2 Group B inspection, (JAN, JANTX, and JANTXV). Separate samples may be used for each step. In the event of a lot failure, the resubmission requirements of MIL-PRF-19500 shall apply. In addition, all catastrophic failures during CI shall be analyzed to the extent possible to identify root cause and corrective action.

<u>Step</u>	<u>Method</u>	<u>Condition</u>
1	1026	Steady-state life: 1,000 hours minimum, $V_{CB} = 10$ V dc; power shall be applied and T_A adjusted to achieve $T_J = +150^\circ\text{C}$ minimum, using a minimum of $P_D = 75$ percent of maximum rated P_T as defined in 1.3. $n = 45$ devices, $c = 0$.
2	1048	Blocking life: $T_A = +150^\circ\text{C}$, $V_{CB} = 80$ percent rated voltage, 48 hours minimum. $n = 45$ devices, $c = 0$.
3	1032	High-temperature life (non-operating), $t = 340$ hours, $T_A = +200^\circ\text{C}$. $n = 22$, $c = 0$.

4.4.2.3 Group B sample selection. Samples selected from group B inspection shall meet all of the following requirements:

- a. For JAN, JANTX, and JANTXV samples shall be selected randomly from a minimum of three wafers (or from each wafer in the lot) from each wafer lot. For JANS samples shall be selected from each inspection lot. See MIL-PRF-19500.
- b. Shall be chosen from an inspection lot that has been submitted to and passed table I, subgroup 2 conformance inspection. When the final lead finish is solder or any plating prone to oxidation at high temperature, the samples for life test (subgroups B4 and B5 for JANS, and group B for JAN, JANTX, and JANTXV) may be pulled prior to the application of final lead finish.

4.4.3 Group C inspection. Group C inspection shall be conducted in accordance with the tests and conditions specified for subgroup testing in table E-VII of MIL-PRF-19500 and herein. Electrical measurements (end-points) shall be in accordance with table I, subgroup 2 herein.

<u>Subgroup</u>	<u>Method</u>	<u>Condition</u>
C2	2036	Test condition E; (not applicable for UB or UBC devices).
C5	3131	See 1.3 $R_{\theta JA}$.
C6	1026	$V_{CB} = 10$ V dc; $P_T = 200$ mW, time = 1,000 hrs, adjust T_A to achieve $T_J = +150^\circ\text{C}$ minimum. Not applicable to JAN, JANTX, and JANTXV levels.

MIL-PRF-19500/511H
w/AMENDMENT 2

4.4.3.3 Group C sample selection. Samples for subgroups in group C shall be chosen at random from any inspection lot containing the intended package type and lead finish procured to the same specification which is submitted to and passes table I tests herein for conformance inspection. When the final lead finish is solder or any plating prone to oxidation at high temperature, the samples for C6 life test may be pulled prior to the application of final lead finish. Testing of a subgroup using a single device type enclosed in the intended package type shall be considered as complying with the requirements for that subgroup.

* 4.4.4 Group D inspection. Conformance inspection for hardness assured JANS and JANTXV types shall include the group D tests specified in table II herein. These tests shall be performed as required in accordance with MIL-PRF-19500 and method 1019 of MIL-STD-750 for total ionizing dose, or method 1017 of MIL-STD-750 for neutron fluence, as applicable (see 6.2 herein), except group D, subgroup 2 may be performed separate from other subgroups. Group D inspection may also be performed ahead of the screening lot using die selected in accordance with MIL-PRF-19500 and related documents. Alternate package options may also be substituted for the testing provided there is no adverse effect to the fluence profile.

* 4.4.5 Group E inspection. Group E inspection shall be conducted in accordance with the conditions specified for subgroup testing in appendix E, table E-IX of MIL-PRF-19500 and as specified in table III herein. Electrical measurements (end-points) shall be in accordance with table I, subgroup 2 herein.

4.5 Method of inspection. Methods of inspection shall be as specified in the appropriate tables and as follows.

4.5.1 Pulse measurements. Conditions for pulse measurement shall be as specified in section 4 of MIL-STD-750.

4.5.2 Collector base time constant. This parameter may be determined by applying an RF signal voltage of 0.5 volt (rms) across the collector base terminals, and measuring the ac voltage drop (V_{eb}) with a high impedance RF voltmeter across the emitter base terminals. With $f = 31.8$ MHz used for the 0.5 volt signal, the following computation applies: $r_b' C_c$: (ps) = $10 \times V_{eb}$ (millivolts).

MIL-PRF-19500/511H
w/AMENDMENT 2

TABLE I. Group A inspection.

Inspection <u>1/</u>	MIL-STD-750		Symbol	Limit		Unit
	Method	Conditions		Min	Max	
<u>Subgroup 1 2/</u>						
Visual and mechanical examination <u>3/</u>	2071					
Solderability <u>3/ 4/</u>	2026	n = 15 leads, c = 0				
Resistance to solvents <u>3/ 4/ 5/</u>	1022	n = 15 devices, c = 0				
Temp cycling <u>3/ 4/</u>	1051	Test condition C, 25 cycles. n = 22 devices, c = 0				
Hermetic seal <u>4/</u> Fine leak Gross leak	1071	n = 22 devices, c = 0				
Electrical measurements <u>4/</u>		Table I, subgroup 2				
Bond strength <u>3/ 4/</u>	2037	Precondition T _A = +250°C at t = 24 hrs or T _A = +300°C at t = 2 hrs n = 11 wires, c = 0				
De-cap internal visual	2075	n = 4, c = 0				
<u>Subgroup 2</u>						
Thermal impedance	3131	See 4.3.2	ΔV_{BE}			mV
Collector to emitter breakdown voltage	3011	Bias condition D, I _C = 10 mA dc.	V _{(BR)CEO}	15		V dc
Collector to base cutoff current	3036	Bias Condition D, V _{CB} = 15 V dc.	I _{CBO}		10	μA dc
Emitter-base cutoff current	3061	Bias condition D, V _{EB} = 4.5 V dc.	I _{EBO}		10	μA dc
Collector to emitter cutoff current	3041	Bias condition A; V _{BE} = 0.4 V dc. V _{CE} = 10 V dc	I _{CEX1}		50	nA dc
Collector to emitter cutoff current	3041	Bias condition A; V _{BE} = 2.0 V dc V _{CE} = 10 V dc	I _{CEX2}		5.0	nA dc
Base cutoff current	3061	Bias condition A; V _{EB} = - 2.0 V dc; V _{BC} = 12 V dc	I _{EBX}		5.0	nA dc
Forward-current transfer ratio	3076	V _{CE} = 1.0 V dc; I _C = 1.0 mA dc; pulsed (see 4.5.1).	h _{FE1}	25		

See footnotes at end of table.

MIL-PRF-19500/511H
w/AMENDMENT 2

TABLE I. Group A inspection - Continued.

Inspection 1/	MIL-STD-750		Symbol	Limit		Unit
	Method	Conditions		Min	Max	
<u>Subgroup 2</u> - Continued.						
Forward-current transfer ratio	3076	$V_{CE} = 1.0 \text{ V dc}; I_C = 10 \text{ mA dc};$ pulsed (see 4.5.1).	h_{FE2}	30	150	
Forward-current transfer ratio	3076	$V_{CE} = 1.0 \text{ V dc}; I_C = 30 \text{ mA dc};$ pulsed (see 4.5.1).	h_{FE3}	20		
Base to emitter voltage (non-saturated)	3066	Test condition B; $V_{CE} = 1.0 \text{ V dc};$ $I_C = 1.0 \text{ mA dc}.$	V_{BE1}		0.8	V dc
Base to emitter voltage (non-saturated)	3066	Test condition B; $V_{CE} = 1.0 \text{ V dc};$ $I_C = 10 \text{ mA dc}.$	V_{BE2}		1.0	V dc
Collector to emitter saturated voltage	3071	$I_C = 1.0 \text{ mA dc}; I_B = 0.1 \text{ mA dc}.$	$V_{CE(sat)1}$		0.15	V dc
Collector to emitter saturated voltage	3071	$I_C = 10 \text{ mA dc}; I_B = 1.0 \text{ mA dc};$ pulsed (see 4.5.1).	$V_{CE(sat)2}$		0.35	V dc
<u>Subgroup 3</u>						
High-temperature operation:		$T_A = +150^\circ\text{C}$				
Collector to emitter cutoff current	3041	Bias condition A; $V_{BE} = 2.0 \text{ V dc}$ $V_{CE} = 10 \text{ V dc}.$	I_{CEX3}		5.0	$\mu\text{A dc}$
Low-temperature operation :		$T_A = -55^\circ\text{C}$				
Forward-current transfer ratio	3076	$V_{CE} = 1.0 \text{ V dc}; I_C = 10 \text{ mA dc};$ pulsed (see 4.5.1).	h_{FE4}	15		
<u>Subgroup 4</u>						
Magnitude of common emitter small-signal short-circuit forward- current transfer ratio	3306	$V_{CE} = 4.0 \text{ V dc}; I_C = 5.0 \text{ mA dc};$ $f = 100 \text{ MHz}.$	$ h_{fe1} $	15		
Magnitude of common emitter small-signal short-circuit forward- current transfer ratio	3306	$V_{CE} = 10 \text{ V dc}; I_C = 10 \text{ mA dc};$ $f = 100 \text{ MHz}.$	$ h_{fe2} $	20		
Open capacitance (open circuit)	3236	$V_{CB} = 4.0 \text{ V dc}; I_E = 0;$ $100 \text{ kHz} \leq f \leq 1.0 \text{ MHz}.$	C_{obo}		2.5	pF
Input capacitance (output open circuit)	3240	$V_{EB} = 0.5 \text{ V dc}; I_C = 0;$ $100 \text{ kHz} \leq f \leq 1.0 \text{ MHz}.$	C_{ibo}		2.5	pF

See footnotes at end of table.

MIL-PRF-19500/511H
w/AMENDMENT 2

TABLE I. Group A inspection - Continued.

Inspection <u>1/</u>	MIL-STD-750		Symbol	Limit		Unit
	Method	Conditions		Min	Max	
<u>Subgroup 4</u> - Continued.						
Collector-base time constant		$V_{CE} = 4.0 \text{ V dc}; I_C = 5.0 \text{ mA dc};$ $f = 31.8 \text{ MHz};$ see 4.5.2 and figure 5.	$r_b'C_{c1}$		60	ps
Collector-base time constant		$V_{CE} = 4.0 \text{ V dc}; I_C = 10 \text{ mA dc};$ $f = 31.8 \text{ MHz};$ see 4.5.2 and figure 5.	$r_b'C_{c2}$		50	ps
Pulse response:	3251	Test condition B, except test circuit and pulse requirements in accordance with figure 6 herein.				
Turn-on time		$V_{CC} = 17 \text{ V dc};$ $I_C = 10 \text{ mA dc}.$	t_{on}		2.5	ns
Turn-off time		$V_{CC} = 17 \text{ V dc};$ $I_C = 10 \text{ mA dc}.$	t_{off}		3.5	ns
<u>Subgroups 5, 6, and 7</u>						
Not applicable						

1/ For sampling plan (unless otherwise specified) see MIL-PRF-19500.

2/ For resubmission of failed test in subgroup 1 of table I, double the sample size of the failed test or sequence of tests. A failure in table I, subgroup 1 shall not require retest of the entire subgroup. Only the failed test shall be rerun upon submission.

3/ Separate samples may be used.

4/ Not required for JANS devices.

5/ Not required for laser marked devices.

MIL-PRF-19500/511H
w/AMENDMENT 2

* TABLE II. Group D inspection and end-point limits.

Inspection <u>1/</u>	MIL-STD-750		Symbol	Limits		Unit
	Method	Conditions		Min	Max	
<u>Subgroup 1 2/</u>						
Steady-state neutron irradiation	1017	Neutron exposure $V_{CES} = 0$ V				
Collector to emitter breakdown voltage	3011	Bias condition D; $I_C = 10$ mA dc	$V_{(BR)CEO}$	15		V dc
Collector to base cutoff current	3036	Bias condition D; $V_{CBO} = 15$ V	I_{CBO}		20	μ A dc
Emitter-base cutoff current	3061	Bias condition D; $V_{EB} = 4.5$ V	I_{EBO}		20	μ A dc
Collector to emitter cutoff current	3041	Bias condition A; $V_{BE} = 0.4$ V dc, $V_{CE} = 10$ V dc	I_{CEX1}		100	η A dc
Collector to emitter cutoff current	3041	Bias condition A; $V_{BE} = 2.0$ V dc, $V_{CE} = 10$ V dc	I_{CEX2}		10	η A dc
Base cutoff current	3061	$V_{BE} = 2.0$ V dc; $V_{CE} = 10$ V dc, see 4.5.3.	I_{BEX}		10	η A dc
Forward-current transfer ratio	3076	$V_{CE} = 1.0$ V dc, $I_C = 1.0$ mA dc; pulsed (see 4.5.1)	$[h_{FE1}]$	[12.5] <u>3/</u>		
Forward-current transfer ratio	3076	$V_{CE} = 1.0$ V dc, $I_C = 10$ mA dc; pulsed (see 4.5.1)	$[h_{FE2}]$	[15] <u>3/</u>	150	
Forward-current transfer ratio	3076	$V_{CE} = 1.0$ V dc, $I_C = 30$ mA dc; pulsed (see 4.5.1)	$[h_{FE3}]$	[10] <u>3/</u>		
Base to emitter voltage (non-saturated)	3066	Test condition B; $V_{CE} = 1.0$ V; $I_C = 1.0$ mA dc	V_{BE1}		0.92	V dc
Base to emitter voltage (non-saturated)	3066	Test condition B; $V_{CE} = 1.0$ V; $I_C = 10$ mA dc	V_{BE2}		1.15	V dc
Collector to emitter saturated voltage	3071	$I_C = 1.0$ mA dc; $I_B = 0.1$ mA dc	$V_{CE(sat)1}$		0.18	V dc
Collector to emitter saturated voltage	3071	$I_C = 10$ mA dc; $I_B = 1.0$ mA dc; pulsed (see 4.5.1)	$V_{CE(sat)2}$		0.40	V dc

See footnotes at end of table.

MIL-PRF-19500/511H
w/AMENDMENT 2

* TABLE II. Group D inspection and end-point limits – Continued.

Inspection <u>1/</u>	MIL-STD-750		Symbol	Limits		Unit
	Method	Conditions		Min	Max	
<u>Subgroup 2</u>						
Steady-state total dose irradiation	1019	Gamma exposure $V_{CES} = 12$ V				
Collector to emitter breakdown voltage	3011	Bias condition D; $I_C = 10$ mA dc	$V_{(BR)CEO}$	15		V dc
Collector to base cutoff current	3036	Bias condition D; $V_{CBO} = 15$ V	I_{CBO}		20	μ A dc
Emitter-base cutoff current	3061	Bias condition D; $V_{EB} = 4.5$ V	I_{EBO}		20	μ A dc
Collector to emitter cutoff current	3041	Bias condition A; $V_{BE} = 0.4$ V dc, $V_{CE} = 10$ V dc	I_{CEX1}		100	η A dc
Collector to emitter cutoff current	3041	Bias condition A; $V_{BE} = 2.0$ V dc, $V_{CE} = 10$ V dc	I_{CEX2}		10	η A dc
Base cutoff current	3061	$V_{BE} = 2.0$ V dc; $V_{CE} = 10$ V dc, see 4.5.3.	I_{BEX}		10	η A dc
Forward-current transfer ratio	3076	$V_{CE} = 1.0$ V dc, $I_C = 1.0$ mA dc; pulsed (see 4.5.1)	$[h_{FE1}]$	[12.5] <u>3/</u>		
Forward-current transfer ratio	3076	$V_{CE} = 1.0$ V dc, $I_C = 10$ mA dc; pulsed (see 4.5.1)	$[h_{FE2}]$	[15] <u>3/</u>	150	
Forward-current transfer ratio	3076	$V_{CE} = 1.0$ V dc, $I_C = 30$ mA dc; pulsed (see 4.5.1)	$[h_{FE3}]$	[10] <u>3/</u>		
Base to emitter voltage (non-saturated)	3066	Test condition B; $V_{CE} = 1.0$ V; $I_C = 1.0$ mA dc	V_{BE1}		0.92	V dc
Base to emitter voltage (non-saturated)	3066	Test condition B; $V_{CE} = 1.0$ V; $I_C = 10$ mA dc	V_{BE2}		1.15	V dc
Collector to emitter saturated voltage	3071	$I_C = 1.0$ mA dc; $I_B = 0.1$ mA dc	$V_{CE(sat)1}$		0.18	V dc
Collector to emitter saturated voltage	3071	$I_C = 10$ mA dc; $I_B = 1.0$ mA dc; pulsed (see 4.5.1)	$V_{CE(sat)2}$		0.40	V dc

1/ For sampling plan, see MIL-PRF-19500.

2/ See 6.2.e herein.

3/ See method 1019 of MIL-STD-750, for how to determine $[h_{FE}]$ by first calculating the $\Delta(1/h_{FE})$ from the pre and post radiation h_{FE} . Notice that $[h_{FE}]$ is not the same as h_{FE} and cannot be measured directly. The $[h_{FE}]$ value can never exceed the pre-radiation minimum h_{FE} that it is based upon.

MIL-PRF-19500/511H
w/AMENDMENT 2

TABLE III. Group E inspection (all quality levels) for qualification or re-qualification only.

Inspection	MIL-STD-750		Qualification
	Method	Conditions	
<u>Subgroup 1</u>			45 devices c = 0
Temperature cycling (air to air)	1051	Test condition C, 500 cycles.	
Hermetic seal Fine leak Gross leak	1071		
Electrical measurements		See table I, subgroup 2.	
<u>Subgroup 2</u>			45 devices c = 0
Intermittent life	1037	$V_{CB} = 10 \text{ V dc}$; 6,000 cycles, $t_{ON} = t_{OFF} = 3 \text{ minutes}$, $P_{D(ON)} = P_D \text{ max rated in accordance with 1.3}$; $P_{D(OFF)} = 0$.	
Electrical measurements		See table I, subgroup 2.	
<u>Subgroup 4</u>			Sample size N/A
Thermal impedance curves		See 4.2.2.1.	
<u>Subgroup 5</u>			
Not applicable			
<u>Subgroup 6</u>			
ESD	1020		
<u>Subgroup 8</u>			45 devices c = 0
Reverse stability	1033	Condition B.	

MIL-PRF-19500/511H
w/AMENDMENT 2

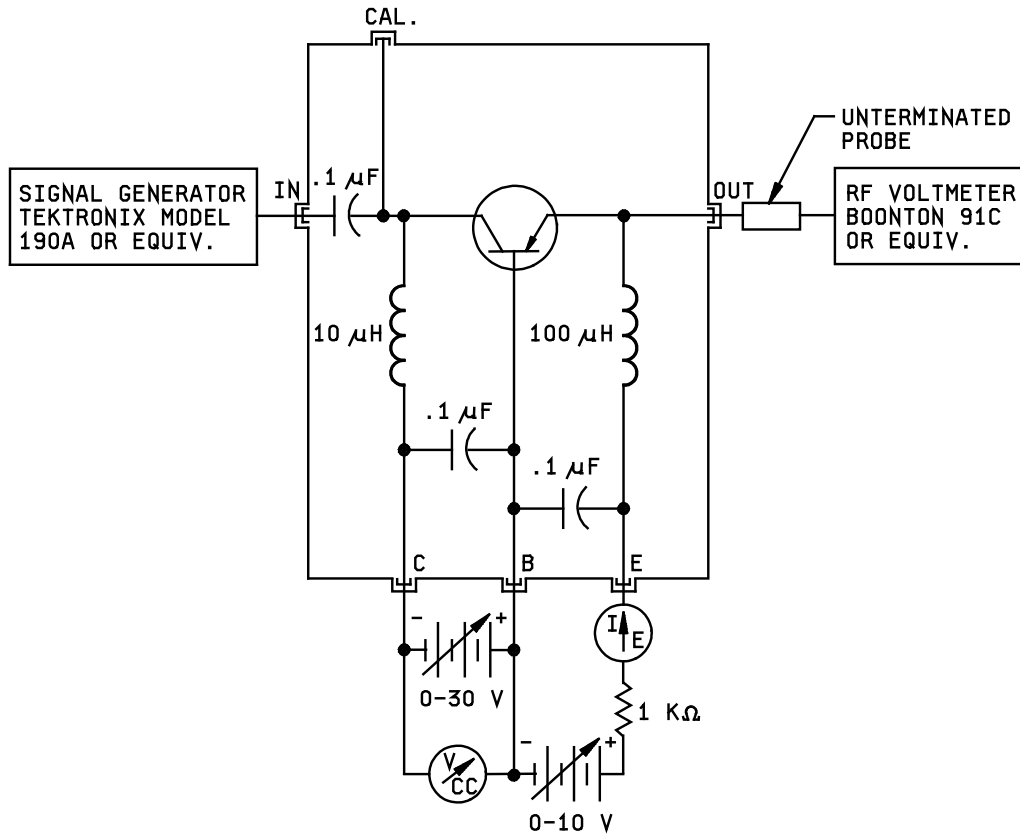

Procedure:

1. Set signal generator to 31.8 MHz and connect to "in" connector on test jig.
2. Connect low voltage dc power supplies as shown. A 1 k ohm resistor should be placed in series with the emitter power supply to prevent damage to transistors being tested.
3. Place transistor to be tested in socket. Set collector supply for $V_{CE} = 4.0$ V dc, and emitter supply for I_C as specified.
4. Connect RF voltmeter with unterminated probe adapter to "CAL" connector on test jig. Adjust signal generator until RF voltage is 0.5 volts. (Note: Decade switching of voltmeter should be accurate from 1 mV to 3 volts. If not, input voltage may be set using voltage dividers, utilizing lower scales of the RF voltmeter. If this is done, the voltage dividers should be left in place when the voltmeter is removed, as they constitute a load on the input of the circuit.)
5. Remove RF voltmeter from "CAL" connector to "OUT" connector. Meter will now read $r_b' C_c$ as follows:

Meter range full scale	$r_b' C_c$ range
0.003 volts	10 to 30 ps
0.01 volts	30 to 100 ps
0.03 volts	100 to 300 ps

FIGURE 5. Collector base time constant test circuit (an equivalent circuit may be used).

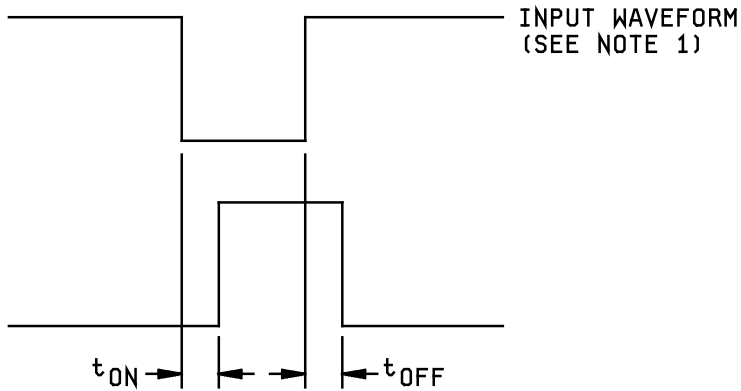
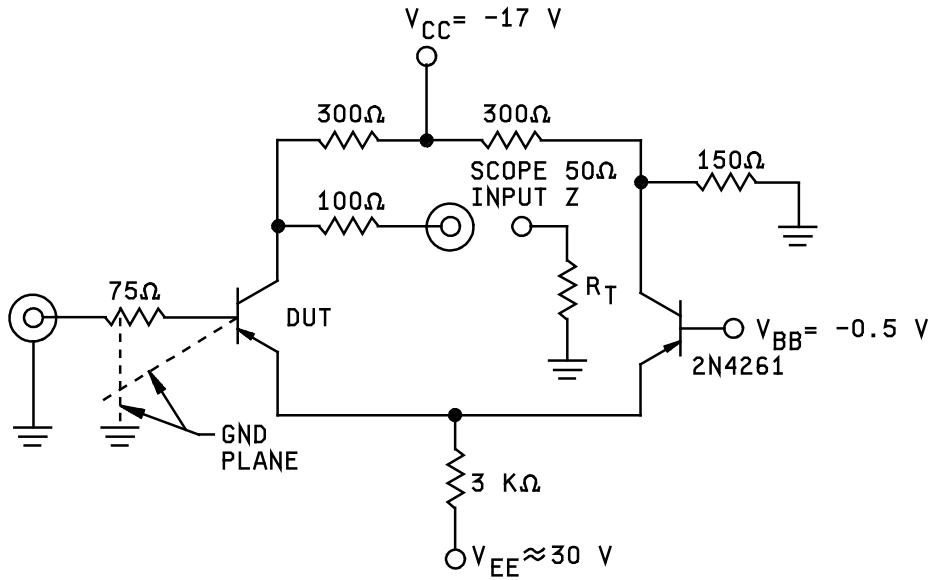

NOTES:

1. The input waveform is supplied by a pulse generator with the following characteristics:
 $Z_{OUT} = 50$ ohms; PW = 30 ns; duty cycle ≤ 2 percent.
2. Resistors shall be noninductive types.
3. The dc power supplies may require additional bypassing in order to minimize ringing.

FIGURE 6. Switching time test circuit and waveforms.

5. PACKAGING

5.1 Packaging. For acquisition purposes, the packaging requirements shall be as specified in the contract or order (see 6.2). When packaging of materiel is to be performed by DoD or in-house contractor personnel, these personnel need to contact the responsible packaging activity to ascertain packaging requirements. Packaging requirements are maintained by the Inventory Control Point's packaging activities within the Military Service or Defense Agency, or within the Military Service's system commands. Packaging data retrieval is available from the managing Military Department's or Defense Agency's automated packaging files, CD-ROM products, or by contacting the responsible packaging activity.

6. NOTES

(This section contains information of a general or explanatory nature that may be helpful, but is not mandatory. The notes specified in MIL-PRF-19500 are applicable to this specification.)

6.1 Intended use. Semiconductors conforming to this specification are intended for original equipment design applications and logistic support of existing equipment.

6.2 Acquisition requirements. Acquisition documents should specify the following:

- a. Title, number, and date of this specification.
- b. Packaging requirements (see 5.1).
- c. Lead finish (see 3.4.1).
- d. Product assurance level and type designator.

* e. For acquisition of RHA designed devices, table II, subgroup 1 testing of group D is optional. If subgroup 1 testing is desired, it should be specified in the contract.

6.3 Qualification. With respect to products requiring qualification, awards will be made only for products which are, at the time of award of contract, qualified for inclusion in Qualified Manufacturers List (QML 19500) whether or not such products have actually been so listed by that date. The attention of the contractors is called to these requirements, and manufacturers are urged to arrange to have the products that they propose to offer to the Federal Government tested for qualification in order that they may be eligible to be awarded contracts or orders for the products covered by this specification. Information pertaining to qualification of products may be obtained from DLA Land and Maritime, ATTN: VQE, P.O. Box 3990, Columbus, OH 43218-3990 or e-mail vqe.chief@dla.mil. An online listing of products qualified to this specification may be found in the Qualified Products Database (QPD) at <https://assist.daps.dla.mil>.

MIL-PRF-19500/511H
w/AMENDMENT 2

6.4. Suppliers of JANHC and JANKC die. The qualified JANHC and JANKC suppliers with the applicable letter version (example JANHCA2N4261) will be identified on the QML.

Die ordering information	
PIN	Manufacturer
	34156
2N4261	JANHCA2N4261, JANKCA2N4261

* 6.5 Changes from previous issue. The margins of this specification are marked with asterisks to indicate modifications generated by this amendment. This was done as a convenience only and the Government assumes no liability whatsoever for any inaccuracies in these notations. Bidders and contractors are cautioned to evaluate the requirements of this document based on the entire content irrespective of the marginal notation.

Custodians:
Army - CR
Air Force - 85
NASA - NA
DLA - CC

Preparing activity:
DLA - CC
(Project 5961-2011-092)

Review activities:
Air Force - 19, 71, 99

NOTE: The activities listed above were interested in this document as of the date of this document. Since organizations and responsibilities can change, you should verify the currency of the information above using the ASSIST Online database at <https://assist.daps.dla.mil/>.