

REVISIONS			
LTR	DESCRIPTION	DATE (YR-MO-DA)	APPROVED
A	Changes are in accordance with the notice of revision 5962-R019-94. - tvn	93-11-02	Monica L. Poelking
B	Changes are in accordance with the notice of revision 5962-R090-94. - tvn	94-03-29	Monica L. Poelking
C	Changes are in accordance with the notice of revision 5962-R020-96. - bjm	96-10-28	Monica L. Poelking
D	Incorporate the previous notice of revisions. Update the boilerplate to the current requirements of MIL-PRF-38535. - jak	08-02-27	Thomas M. Hess
E	Add footnote <u>10</u> for test condition of total power supply current (I _{CCCT}) to table I. - LTG	10-05-14	Thomas M. Hess
F	Add new vendor CAGE code 3D TT2. - LTG Update boilerplate paragraphs to the current requirements of MIL-PRF-38535. - LTG	16-04-26	Muhammad Akbar
G	Update Source of Supply for cage 0C7V7. Update boilerplate paragraphs to current requirements as specified in MIL-PRF-38535. - jwc	23-02-21	Muhammad Akbar



THE ORIGINAL FIRST SHEET OF THIS DRAWING HAS BEEN REPLACED.

Revision Status of Sheets

REV																				
SHEET																				
REV	G	G	G	G	G	G	G	G	G	G	G	G	G	G	G	G				
SHEET	1	2	3	4	5	6	7	8	9	10	11	12	13	14	15	16	17			

PMIC N/A																			
STANDARD MICROCIRCUIT DRAWING	PREPARED BY Joseph A. Kerby	DLA LAND AND MARITIME COLUMBUS, OHIO 43218-3990 https://www.dla.mil/LandandMaritime																	
	CHECKED BY Thomas J. Ricciuti																		
THIS DRAWING IS AVAILABLE FOR USE BY ALL DEPARTMENTS AND AGENCIES OF THE DEPARTMENT OF DEFENSE	APPROVED BY Monica L. Poelking	MICROCIRCUIT, DIGITAL, FAST CMOS, OCTAL D-TYPE FLIP-FLOP WITH ASYNCHRONOUS MASTER RESET, TTL COMPATIBLE INPUTS AND LIMITED OUTPUT VOLTAGE SWING, MONOLITHIC SILICON																	
	DRAWING APPROVAL DATE 93-03-23																		
AMSC N/A	REVISION LEVEL G	SIZE A	CAGE CODE 67268	5962 92215															
		SHEET 1 OF 17																	

1. SCOPE

1.1 Scope. This drawing documents two product assurance class levels consisting of high reliability (device class Q and M) and space application (device class V). A choice of case outlines and lead finishes are available and are reflected in the Part or Identifying Number (PIN). When available, a choice of Radiation Hardness Assurance (RHA) levels is reflected in the PIN.

1.2 PIN. The PIN is as shown in the following example:

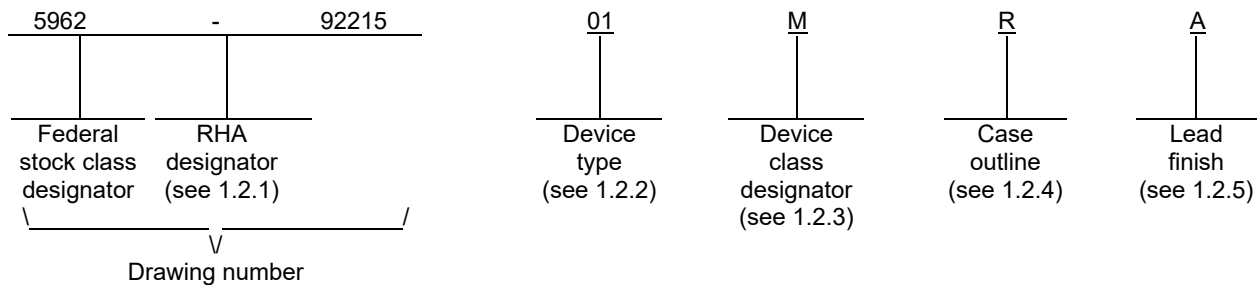

1.2.1 RHA designator. Device classes Q and V RHA marked devices meet the MIL-PRF-38535 specified RHA levels and are marked with the appropriate RHA designator. Device class M RHA marked devices meet the MIL-PRF-38535, appendix A specified RHA levels and are marked with the appropriate RHA designator. A dash (-) indicates a non-RHA device.

1.2.2 Device type(s). The device type(s) identify the circuit function as follows:

<u>Device type</u>	<u>Generic number</u>	<u>Circuit function</u>
01, 02	54FCT273T	Octal D-type flip-flop with asynchronous master reset, TTL compatible inputs and limited output voltage swing
03, 04	54FCT273AT	Octal D-type flip-flop with asynchronous master reset, TTL compatible inputs and limited output voltage swing
05, 06	54FCT273CT	Octal D-type flip-flop with asynchronous master reset, TTL compatible inputs and limited output voltage swing

1.2.3 Device class designator. The device class designator is a single letter identifying the product assurance level as follows:

<u>Device class</u>	<u>Device requirements documentation</u>
M	Vendor self-certification to the requirements for MIL-STD-883 compliant, non-JAN class level B microcircuits in accordance with MIL-PRF-38535, appendix A
Q or V	Certification and qualification to MIL-PRF-38535

1.2.4 Case outline(s). The case outline(s) are as designated in MIL-STD-1835 and as follows:

<u>Outline letter</u>	<u>Descriptive designator</u>	<u>Terminals</u>	<u>Package style</u>
R	GDIP1-T20 or CDIP2-T20	20	Dual-in-line
S	GDFP2-F20 or CDFP3-T20	20	Flat pack
2	CQCC1-N20	20	Leadless-chip-carrier

1.2.5 Lead finish. The lead finish is as specified in MIL-PRF-38535 for device classes Q and V or MIL-PRF-38535, appendix A for device class M.

STANDARD MICROCIRCUIT DRAWING DLA LAND AND MARITIME COLUMBUS, OHIO 43218-3990	SIZE A		5962-92215
		REVISION LEVEL G	SHEET 2

1.3 Absolute maximum ratings. 1/ 2/ 3/

Supply voltage range (V_{CC})	-0.5 V dc to +7.0 V dc
DC input voltage range (V_{IN})	-0.5 V dc to $V_{CC} + 0.5$ V dc 4/
DC output voltage range (V_{OUT})	-0.5 V dc to $V_{CC} + 0.5$ V dc 4/
DC input clamp current (I_{IK}) ($V_{IN} = -0.5$ V)	-20 mA
DC output clamp current (I_{OK}) ($V_{OUT} = -0.5$ V and +7.0 V)	± 20 mA
DC output source current (I_{OH}) (per output)	-30 mA
DC output sink current (I_{OL}) (per output)	+70 mA
DC V_{CC} current (I_{CC})	± 260 mA
Ground current (I_{GND})	+550 mA
Storage temperature range (T_{STG})	-65°C to +150°C
Case temperature under bias (T_{BIAS})	-65°C to +135°C
Maximum power dissipation (P_D)	500 mW
Lead temperature (soldering, 10 seconds)	+300°C
Thermal resistance, junction-to-case (θ_{JC})	See MIL-STD-1835
Junction temperature (T_J)	+175°C

1.4 Recommended operating conditions. 2/ 3/

Supply voltage range (V_{CC})	+4.5 V dc to +5.5 V dc
Input voltage range (V_{IN})	+0.0 V dc to V_{CC}
Output voltage range (V_{OUT})	+0.0 V dc to V_{CC}
Maximum low level input voltage (V_{IL})	0.8 V
Minimum high level input voltage (V_{IH})	2.0 V
Case operating temperature range (T_C)	-55°C to +125°C
Maximum input rise or fall rate ($\Delta t/\Delta V$):	
(from $V_{IN} = 0.3$ V to 2.7 V, 2.7 V to 0.3 V)	5 ns/V
Maximum high level output current (I_{OH}):	
Device types 01, 03, and 05	-6 mA
Device types 02, 04, and 06	-12 mA
Maximum low level output current (I_{OL})	32 mA

1/ Stresses above the absolute maximum rating may cause permanent damage to the device. Extended operation at the maximum levels may degrade performance and affect reliability.

2/ Unless otherwise noted, all voltages are referenced to GND.

3/ The limits for the parameters specified herein shall apply over the full specified V_{CC} range and case temperature range of -55°C to +125°C.

4/ For $V_{CC} \geq 6.5$ V, the upper limit on the range is limited to 7.0 V.

STANDARD MICROCIRCUIT DRAWING DLA LAND AND MARITIME COLUMBUS, OHIO 43218-3990	SIZE A		5962-92215
		REVISION LEVEL G	SHEET 3

2. APPLICABLE DOCUMENTS

2.1 Government specification, standards, and handbooks. The following specification, standards, and handbooks form a part of this drawing to the extent specified herein. Unless otherwise specified, the issues of these documents are those cited in the solicitation or contract.

DEPARTMENT OF DEFENSE SPECIFICATION

MIL-PRF-38535 - Integrated Circuits, Manufacturing, General Specification for.

DEPARTMENT OF DEFENSE STANDARDS

MIL-STD-883 - Test Method Standard Microcircuits.
 MIL-STD-1835 - Interface Standard Electronic Component Case Outlines.

DEPARTMENT OF DEFENSE HANDBOOKS

MIL-HDBK-103 - List of Standard Microcircuit Drawings.
 MIL-HDBK-780 - Standard Microcircuit Drawings.

(Copies of these documents are available online at <https://quicksearch.dla.mil>).

2.2 Order of precedence. In the event of a conflict between the text of this drawing and the references cited herein, the text of this drawing takes precedence. Nothing in this document, however, supersedes applicable laws and regulations unless a specific exemption has been obtained.

3. REQUIREMENTS

3.1 Item requirements. The individual item requirements for device classes Q and V shall be in accordance with MIL-PRF-38535 as specified herein, or as modified in the device manufacturer's Quality Management (QM) plan. The modification in the QM plan shall not affect the form, fit, or function as described herein. The individual item requirements for device class M shall be in accordance with MIL-PRF-38535, appendix A for non-JAN class level B devices and as specified herein.

3.2 Design, construction, and physical dimensions. The design, construction, and physical dimensions shall be as specified in MIL-PRF-38535 and herein for device classes Q and V or MIL-PRF-38535, appendix A and herein for device class M.

3.2.1 Case outlines. The case outlines shall be in accordance with 1.2.4 herein.

3.2.2 Terminal connections. The terminal connections shall be as specified on figure 1.

3.2.3 Truth table. The truth table shall be as specified on figure 2.

3.2.4 Logic diagram. The logic diagram shall be as specified on figure 3.

3.2.5 Ground bounce load circuit and waveforms. The ground bounce load circuit and waveforms shall be as specified on figure 4.

3.2.6 Switching waveforms and test circuit. The switching waveforms and test circuit shall be as specified on figure 5.

3.3 Electrical performance characteristics and postirradiation parameter limits. Unless otherwise specified herein, the electrical performance characteristics and postirradiation parameter limits are as specified in table I and shall apply over the full case operating temperature range.

3.4 Electrical test requirements. The electrical test requirements shall be the subgroups specified in table II. The electrical tests for each subgroup are defined in table I.

STANDARD MICROCIRCUIT DRAWING DLA LAND AND MARITIME COLUMBUS, OHIO 43218-3990	SIZE A		5962-92215
		REVISION LEVEL G	SHEET 4

3.5 Marking. The part shall be marked with the PIN listed in 1.2 herein. In addition, the manufacturer's PIN may also be marked. For packages where marking of the entire SMD PIN number is not feasible due to space limitations, the manufacturer has the option of not marking the "5962-" on the device. For RHA product using this option, the RHA designator shall still be marked. Marking for device classes Q and V shall be in accordance with MIL-PRF-38535. Marking for device class M shall be in accordance with MIL-PRF-38535, appendix A.

3.5.1 Certification/compliance mark. The certification mark for device classes Q and V shall be a "QML" or "Q" as required in MIL-PRF-38535. The compliance mark for device class M shall be a "C" as required in MIL-PRF-38535, appendix A.

3.6 Certificate of compliance. For device classes Q and V, a certificate of compliance shall be required from a QML-38535 listed manufacturer in order to supply to the requirements of this drawing (see 6.6.1 herein). For device class M, a certificate of compliance shall be required from a manufacturer in order to be listed as an approved source of supply in MIL-HDBK-103 (see 6.6.2 herein). The certificate of compliance submitted to DLA Land and Maritime-VA prior to listing as an approved source of supply for this drawing shall affirm that the manufacturer's product meets, for device classes Q and V, the requirements of MIL-PRF-38535 and herein or for device class M, the requirements of MIL-PRF-38535, appendix A and herein.

3.7 Certificate of conformance. A certificate of conformance as required for device classes Q and V in MIL-PRF-38535 or for device class M in MIL-PRF-38535, appendix A shall be provided with each lot of microcircuits delivered to this drawing.

3.8 Notification of change for device class M. For device class M, notification to DLA Land and Maritime-VA of change of product (see 6.2 herein) involving devices acquired to this drawing is required for any change that affects this drawing.

3.9 Verification and review for device class M. For device class M, DLA Land and Maritime, DLA Land and Maritime's agent, and the acquiring activity retain the option to review the manufacturer's facility and applicable required documentation. Offshore documentation shall be made available onshore at the option of the reviewer.

3.10 Microcircuit group assignment for device class M. Device class M devices covered by this drawing shall be in microcircuit group number 38 (see MIL-PRF-38535, appendix A).

STANDARD MICROCIRCUIT DRAWING DLA LAND AND MARITIME COLUMBUS, OHIO 43218-3990	SIZE A		5962-92215
		REVISION LEVEL G	SHEET 5

TABLE I. Electrical performance characteristics.

Test and MIL-STD-883 test method <u>1/</u>	Symbol	Test conditions <u>2/</u> -55°C ≤ T _C ≤ +125°C +4.5 V ≤ V _{CC} ≤ +5.5 V unless otherwise specified	Device type	V _{CC}	Group A subgroups	Limits <u>3/</u>		Unit
						Min	Max	
High level output voltage 3006	V _{OH1} <u>4/</u>	For all inputs affecting output under test V _{IN} = V _{IH} = 2.0 V or V _{IL} = 0.8 V For all other inputs V _{IN} = V _{CC} or GND I _{OH} = -300 μA	01, 03, 05	4.5 V	1, 2, 3	2.7	V _{CC} -0.5	V
			02, 04, 06			3.0	V _{CC} -0.5	
	V _{OH2}	For all inputs affecting output under test V _{IN} = V _{IH} = 2.0 V or V _{IL} = 0.8 V For all other inputs V _{IN} = V _{CC} or GND	I _{OH} = -6 mA I _{OH} = -12 mA I _{OH} = -12 mA	01, 03, 05 02, 04, 06	4.5 V	1, 2, 3	2.4 2.0 2.4	V _{CC} -0.5 V _{CC} -0.5 V _{CC} -0.5
Low level output voltage 3007	V _{OL1} <u>4/</u>	For all inputs affecting output under test V _{IN} = V _{IH} = 2.0 V or V _{IL} = 0.8 V For all other inputs V _{IN} = V _{CC} or GND I _{OL} = +300 μA	All	4.5 V	1, 2, 3		0.20	V
	V _{OL2}	For all inputs affecting output under test V _{IN} = V _{IH} = 2.0 V or V _{IL} = 0.8 V For all other inputs V _{IN} = V _{CC} or GND I _{OL} = +32 mA	All	4.5 V	1, 2, 3		0.55	V
Negative input clamp voltage 3022	V _{IC}	For input under test, I _{IN} = -18 mA	01, 03, 05	4.5 V	1, 2, 3		-1.2	V
		For input under test, I _{IN} = -15 mA	02, 04, 06				-1.3	
Input current high 3010	I _{IH}	For input under test V _{IN} = V _{CC} For all other inputs V _{IN} = V _{CC} or GND	01, 03, 05	5.5 V	1, 2		1.0	μA
			02, 04, 06		3	5.0		
					1, 2	1.0		
					3	5.0		
Input current low 3009	I _{IL}	For input under test V _{IN} = GND For all other inputs V _{IN} = V _{CC} or GND	01, 03, 05	5.5 V	1, 2		-1.0	μA
			02, 04, 06		3	-5.0		
					1, 2	-1.0		
					3	-5.0		
Input capacitance 3012	C _{IN} <u>5/</u>	See 4.4.1c T _C = +25°C	All	GND	4		10	pF
Output capacitance 3012	C _{OUT} <u>5/</u>	See 4.4.1c T _C = +25°C	All	GND	4		12	pF
Short circuit output current 3005	I _{OS} <u>6/</u>	For all inputs, V _{IN} = V _{CC} or GND V _{OUT} = GND	All	5.5 V	1, 2, 3	-60	-225	mA
Dynamic power supply current	I _{CCD} <u>4/ 7/</u>	Outputs open	All	5.5 V	4, 5, 6		0.25	mA/ MHz•Bit

See footnotes at end of table.

STANDARD MICROCIRCUIT DRAWING DLA LAND AND MARITIME COLUMBUS, OHIO 43218-3990	SIZE A		5962-92215
		REVISION LEVEL G	SHEET 6

TABLE I. Electrical performance characteristics - Continued.

Test and MIL-STD-883 test method <u>1/</u>	Symbol	Test conditions <u>2/</u> -55°C ≤ T _C ≤ +125°C +4.5 V ≤ V _{CC} ≤ +5.5 V unless otherwise specified		Device type	V _{CC}	Group A subgroups	Limits <u>3/</u>		Unit
							Min	Max	
Quiescent supply current delta, TTL input level 3005	ΔI_{CC} <u>8/</u>	For input under test V _{IN} = V _{CC} - 2.1 V For all other inputs V _{IN} = V _{CC} or GND		All	5.5 V	1, 2, 3		2.0	mA
Quiescent supply current, output high 3005	I _{CC} H	For all other inputs, V _{IN} = V _{CC} or GND		All	5.5 V	1, 2, 3		1.5	mA
Quiescent supply current, output low 3005	I _{CC} L	For all other inputs, V _{IN} = V _{CC} or GND		All	5.5 V	1, 2, 3		1.5	mA
Total supply current	I _{CC} T <u>9/ 10/</u>	Outputs open MR = V _{CC} f _{CP} = 10 MHz 50% duty cycle One bit toggling f _i = 5 MHz 50% duty cycle For nonswitching inputs, V _{IN} = V _{CC} or GND	For switching inputs, V _{IN} = V _{CC} or GND	All	5.5 V	4, 5, 6		4.0	mA
			For switching inputs, V _{IN} = 3.4 V or GND					4, 5, 6	
		Outputs open <u>4/</u> MR = V _{CC} f _{CP} = 10 MHz 50% duty cycle Eight bits toggling f _i = 2.5 MHz 50% duty cycle For nonswitching inputs, V _{IN} = V _{CC} or GND	For switching inputs, V _{IN} = V _{CC} or GND	All		5.5 V	4, 5, 6		7.8
			For switching inputs, V _{IN} = 3.4 V or GND						4, 5, 6
Low level ground bounce noise	V _{OLP} <u>5/ 11/</u>	V _{IH} = 3.0 V V _{IL} = 0.0 V T _A = +25°C See figure 4		01, 03, 05	5.0 V	4		1500	mV
								02, 04, 06	
	01, 03, 05	5.0 V	4		-1700				
					02, 04, 06	5.0 V	4		-1000
									02, 04, 06

See footnotes at end of table.

STANDARD MICROCIRCUIT DRAWING DLA LAND AND MARITIME COLUMBUS, OHIO 43218-3990	SIZE A		5962-92215
		REVISION LEVEL G	SHEET 7

TABLE I. Electrical performance characteristics - Continued.

Test and MIL-STD-883 test method <u>1/</u>	Symbol	Test conditions <u>2/</u> -55°C ≤ T _C ≤ +125°C +4.5 V ≤ V _{CC} ≤ +5.5 V unless otherwise specified	Device type	V _{CC}	Group A subgroups	Limits <u>3/</u>		Unit	
						Min	Max		
High level V _{CC} bounce noise	V _{OHP} <u>5/ 11/</u>	V _{IH} = 3.0 V V _{IL} = 0.0 V T _A = +25°C See figure 4 See 4.4.1b	01, 03, 05	5.0 V	4		500	mV	
							260		
	V _{OHV} <u>5/ 11/</u>		01, 03, 05	5.0 V	4		-500	mV	
							-340		
Functional test 3014	<u>12/</u>	V _{IH} = 2.0 V, V _{IL} = 0.8 V Verify output V _O See 4.4.1d	All	4.5 V	7, 8	L	H		
				5.5 V		7, 8	L	H	
Propagation delay time, clock to output, CP, Qn 3003	t _{PLH} , t _{PHL} <u>13/</u>	C _L = 50 pF minimum R _L = 500Ω See figure 5	01, 02	4.5 V	9, 10, 11	2.0	15.0	ns	
						03, 04	2.0		8.3
							05, 06		2.0
Propagation delay time, MR to Qn 3003	t _{PZH} , t _{PZL} <u>13/</u>		01, 02	4.5 V	9, 10, 11	2.0	15.0	ns	
						03, 04	2.0		8.3
			05, 06	2.0	6.8				
				Setup time, Dn to CP	t _s		01, 02	4.5 V	9, 10, 11
03, 04	2.0								
	05, 06	2.0							
Hold time, Dn from CP	t _h		01, 02	4.5 V	9, 10, 11	2.0		ns	
						03, 04	1.5		
							05, 06		1.5
Clock pulse width, CP high and low	t _w		01, 02	4.5 V	9, 10, 11	7.0		ns	
						03, 04	6.0		
							05, 06		6.0
Reset pulse width, MR low	t _w		01, 02	4.5 V	9, 10, 11	7.0		ns	
						03, 04	6.0		
							05, 06		6.0
Recovery time, MR to CP	t _{rec}		01, 02	4.5 V	9, 10, 11	5.0		ns	
						03, 04	2.5		
							05, 06		2.5

1/ For tests not listed in the referenced MIL-STD-883 (e.g. ΔICC), utilize the general test procedure of 883 under the conditions listed herein.

2/ Each input/output, as applicable, shall be tested at the specified temperature, for the specified limits, to the tests in table I herein. Output terminals not designated shall be high level logic, low level logic, or open, except for all ICC and ΔICC tests, the output terminals shall be open. When performing these tests, the current meter shall be placed in the circuit such that all current flows through the meter.

**STANDARD
MICROCIRCUIT DRAWING**
DLA LAND AND MARITIME
COLUMBUS, OHIO 43218-3990

SIZE
A

5962-92215

REVISION LEVEL
G

SHEET **8**

TABLE I. Electrical performance characteristics - Continued.

- 3/ For negative and positive voltage and current values, the sign designates the potential difference in reference to GND and the direction of current flow, respectively; and the absolute value of the magnitude, not the sign, is relative to the minimum and maximum limits, as applicable, listed herein. All devices shall meet or exceed the limits specified in table I at $4.5\text{ V} \leq V_{CC} \leq 5.5\text{ V}$.
- 4/ This parameter is guaranteed, if not tested, to the limits specified in table I.
- 5/ This test is required only for group A testing, see 4.4.1 herein.
- 6/ Not more than one output should be shorted at a time. The duration of the short circuit test should not exceed one second.
- 7/ I_{CCD} may be verified by the following equation:

$$I_{CCD} = \frac{I_{CCT} - I_{CC} - D_H N_T \Delta I_{CC}}{f_{CP}/2 + f_i N_i}$$

where I_{CCT} , I_{CC} (I_{CCL} or I_{CCH} in table I), and ΔI_{CC} shall be the measured values of these parameters, for the device under test, when tested as described in table I, herein. The values for D_H , N_T , f_{CP} , f_i , and N_i shall be as listed in the test conditions column for I_{CCT} in table I, herein.

- 8/ This test may be performed either one input at a time (preferred method) or with all input pins simultaneously at $V_{IN} = V_{CC} - 2.1\text{ V}$ (alternate method). Classes Q and V shall use the preferred method. When the test is performed using the alternate test method, the maximum limit is equal to the number of inputs at a high TTL input level times 2.0 mA; and the preferred method and limits are guaranteed.
- 9/ I_{CCT} is calculated as follows:
 $I_{CCT} = I_{CC} + D_H N_T \Delta I_{CC} + I_{CCD}(f_{CP}/2 + f_i N_i)$
 where:
 I_{CC} = Quiescent supply current (any I_{CCL} or I_{CCH})
 D_H = Duty cycle for TTL inputs at 3.4 V
 N_T = Number of TTL inputs at 3.4 V
 ΔI_{CC} = Quiescent supply current delta, TTL inputs at 3.4 V
 I_{CCD} = Dynamic power supply current caused by an input transition pair (HLH or LHL)
 f_{CP} = Clock frequency for registered devices ($f_{CP} = 0$ for nonregistered devices)
 f_i = input frequency
 N_i = Number of inputs at f_i
- 10/ For I_{CC} test in an ATE environment, the effect of parasitic output capacitive loading from the test environment must be taken into account, as its effect is not intended to be included in the test results. The impact must be characterized and appropriate offset factors must be applied to the test result.
- 11/ This test is for qualification only. Ground and V_{CC} bounce tests are performed on a non-switching (quiescent) output and are used to measure the magnitude of induced noise caused by other simultaneously switching outputs. The test is performed on a low noise bench test fixture. For the device under test, all outputs shall be loaded with 500Ω of load resistance and a minimum of 50 pF of load capacitance (see figure 4). Only chip capacitors and resistors shall be used. The output load components shall be located as close as possible to the device outputs. It is suggested, that whenever possible, this distance be kept to less than 0.25 inches. Decoupling capacitors shall be placed in parallel from V_{CC} to ground. The values of these decoupling capacitors shall be determined by the device manufacturer. The low and high level ground and V_{CC} bounce noise is measured at the quiet output using a 1 GHz minimum bandwidth oscilloscope with a 50Ω input impedance.
- 12/ Tests shall be performed in sequence, attributes data only. Functional tests shall include the truth table and other logic patterns used for fault detection. The test vectors used to verify the truth table shall, at a minimum, test all functions of each input and output. All possible input to output logic patterns per function shall be guaranteed, if not tested, to the truth table in figure 2 herein. Functional tests shall be performed in sequence as approved by the qualifying activity on qualified devices. For outputs, $L < 1.5\text{ V}$, $H \geq 1.5\text{ V}$.
- 13/ AC limits at $V_{CC} = 5.5\text{ V}$ are equal to the limits at $V_{CC} = 4.5\text{ V}$ and guaranteed by testing at $V_{CC} = 4.5\text{ V}$. Minimum propagation delay time limits for $V_{CC} = 4.5\text{ V}$ and 5.5 V are guaranteed, if not tested, to the limits specified in table I, herein. For propagation delay tests, all paths must be tested.

STANDARD MICROCIRCUIT DRAWING DLA LAND AND MARITIME COLUMBUS, OHIO 43218-3990	SIZE A		5962-92215
		REVISION LEVEL G	SHEET 9

Device types	All
Case outlines	R, S and 2
Terminal number	Terminal symbol
1	\overline{MR}
2	O0
3	D0
4	D1
5	O1
6	O2
7	D2
8	D3
9	O3
10	GND
11	CP
12	O4
13	D4
14	D5
15	O5
16	O6
17	D6
18	D7
19	O7
20	V _{CC}

Terminal descriptions	
Terminal symbol	Description
D _n (n = 0 to 7)	Data inputs
\overline{MR}	Asynchronous master reset control input
CP	Synchronous timing input
O _n (n = 0 to 7)	Outputs (noninverting)

FIGURE 1. Terminal connections.

STANDARD MICROCIRCUIT DRAWING DLA LAND AND MARITIME COLUMBUS, OHIO 43218-3990	SIZE A		5962-92215
		REVISION LEVEL G	SHEET 10

All device types			
Inputs			Output
\overline{OE}	CP	Dn	On
L	X	X	L
H	↑	h	H
H	↑	l	L

h = High voltage level meeting the set-up and hold timing requirements in table I herein relative to the low-to-high transition of CP.
l = low voltage level meeting the set-up and hold timing requirements in table I herein relative to the low-to-high transition of CP.
H = High voltage level
L = Low voltage level
X = Don't care
↑ = Low-to-high CP transition

FIGURE 2. Truth table.

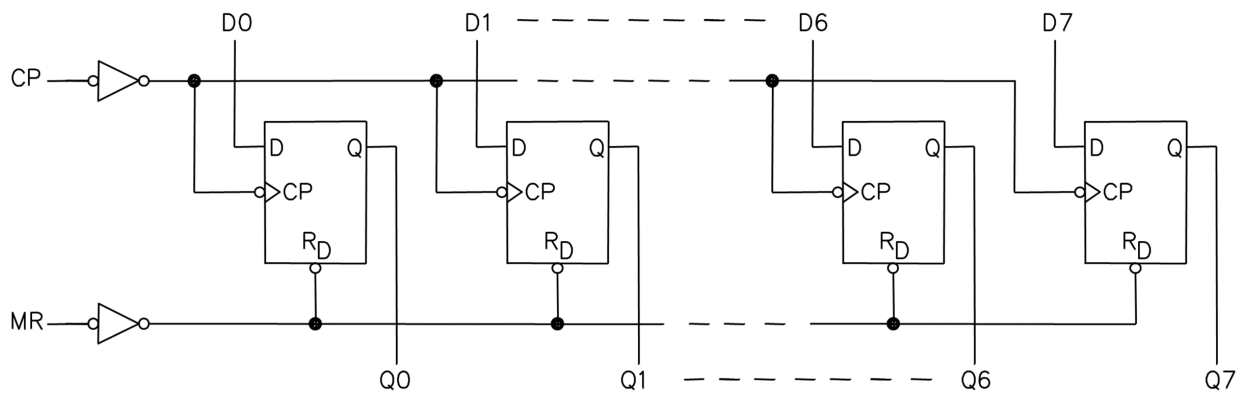

FIGURE 3. Block diagram.

**STANDARD
MICROCIRCUIT DRAWING**
DLA LAND AND MARITIME
COLUMBUS, OHIO 43218-3990

SIZE
A

5962-92215

REVISION LEVEL
G

SHEET **11**

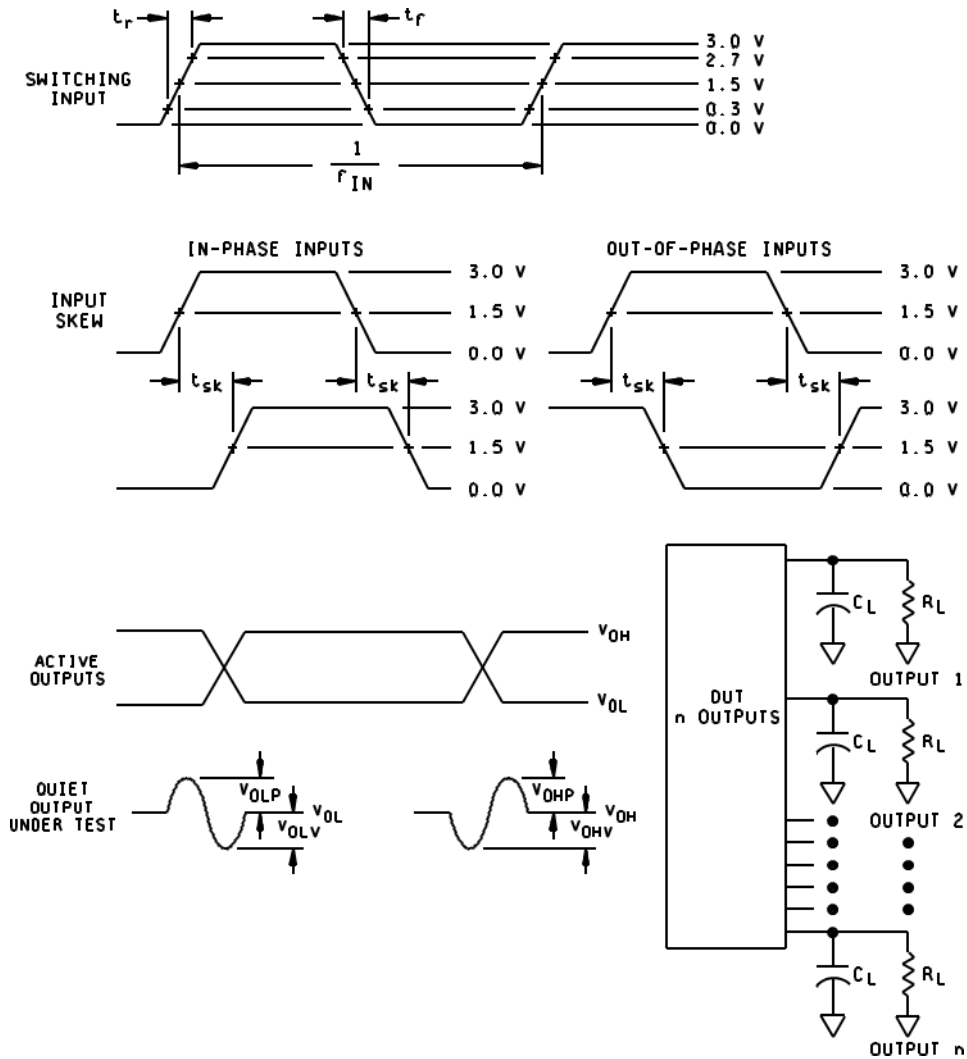

NOTES:

1. C_L includes a 47 pF chip capacitor (-0 percent, +20 percent) and at least 3 pF of equivalent capacitance from the test jig and probe.
2. $R_L = 450\Omega \pm 1$ percent, chip resistor in series with a 50Ω termination. For monitored outputs, the 50Ω termination shall be the 50Ω characteristic impedance of the coaxial connector to the oscilloscope.
3. Input signal to the device under test:
 - a. $V_{IN} = 0.0$ V to 3.0 V; duty cycle = 50 percent; $f_{IN} \geq 1$ MHz.
 - b. $t_r, t_f = 3.0$ ns ± 1.0 ns. For input signal generators incapable of maintaining these values of t_r and t_f , the 3.0 ns limit may be increased up to 10 ns, as needed, maintaining the ± 1.0 ns tolerance and guaranteeing the results at 3.0 ns ± 1.0 ns; skew between any two switching inputs signals (t_{sk}) ≤ 250 ps.

FIGURE 4. Ground bounce waveforms and test circuit.

STANDARD MICROCIRCUIT DRAWING DLA LAND AND MARITIME COLUMBUS, OHIO 43218-3990	SIZE A		5962-92215
		REVISION LEVEL G	SHEET 12

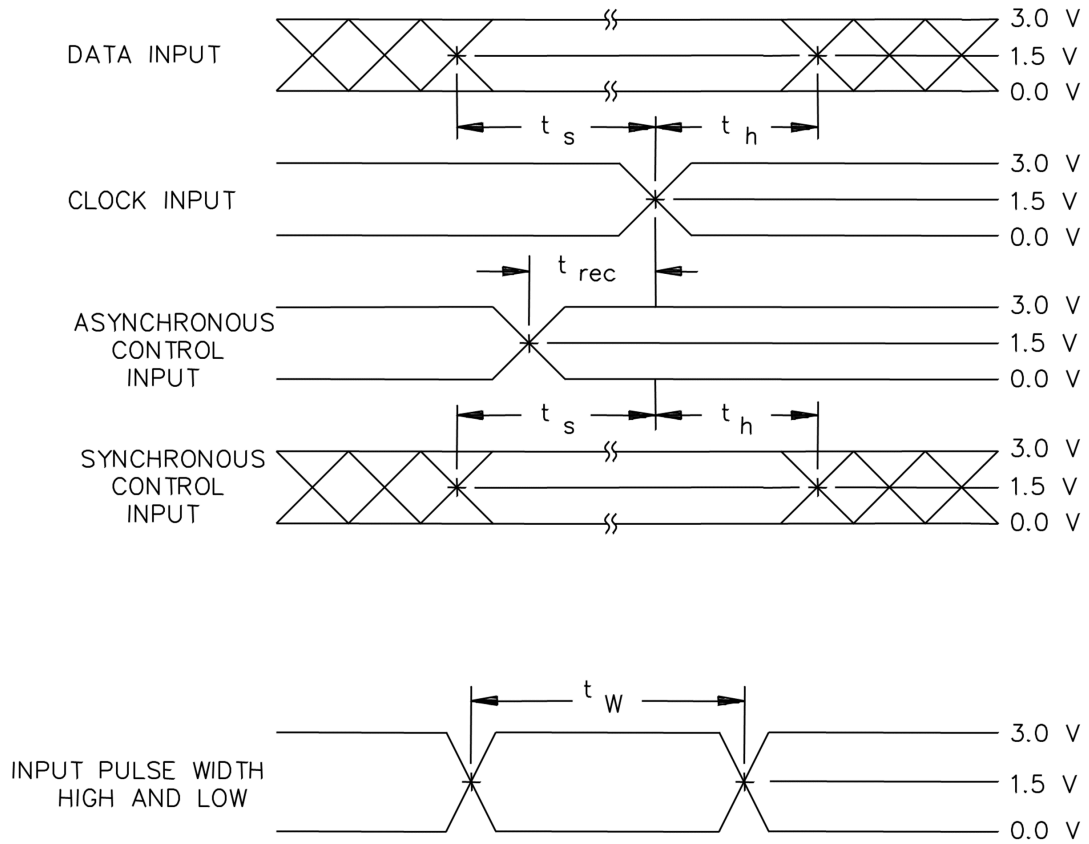

FIGURE 5. Switching waveforms and test circuit.

**STANDARD
MICROCIRCUIT DRAWING**
DLA LAND AND MARITIME
COLUMBUS, OHIO 43218-3990

SIZE
A

5962-92215

REVISION LEVEL
G

SHEET **13**

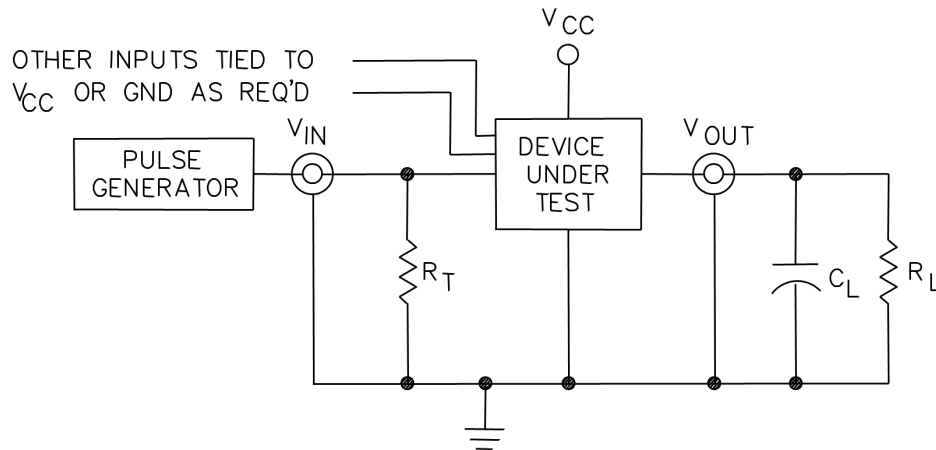
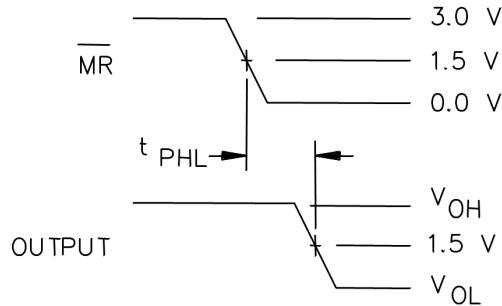
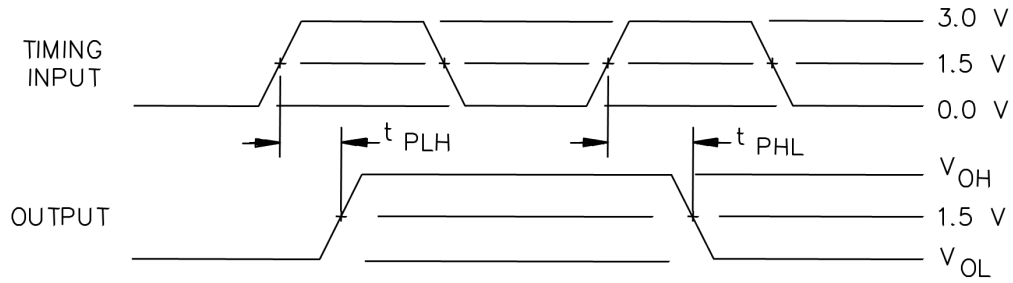

NOTES:

1. $C_L = 50 \text{ pF}$ minimum or equivalent (includes test jig and probe capacitance).
2. $R_L = 500\Omega$ or equivalent.
3. $R_T = 50\Omega$ or equivalent.
4. Input signal from pulse generator: $V_{IN} = 0.0 \text{ V}$ to 3.0 V ; $PRR \leq 10 \text{ MHz}$; $t_r \leq 2.5 \text{ ns}$; $t_f \leq 2.5 \text{ ns}$; t_r and t_f shall be measured from 0.3 V to 2.7 V and from 2.7 V to 0.3 V respectively; duty cycle = 50 percent.
5. Timing parameters shall be tested at a minimum input frequency of 1 MHz.
6. The outputs are measured one at a time with one transition per measurement.

FIGURE 5. Switching waveforms and test circuit – Continued.

STANDARD MICROCIRCUIT DRAWING DLA LAND AND MARITIME COLUMBUS, OHIO 43218-3990	SIZE A		5962-92215
		REVISION LEVEL G	SHEET 14

4. VERIFICATION

4.1 Sampling and inspection. For device classes Q and V, sampling and inspection procedures shall be in accordance with MIL-PRF-38535 or as modified in the device manufacturer's Quality Management (QM) plan. The modification in the QM plan shall not affect the form, fit, or function as described herein. For device class M, sampling and inspection procedures shall be in accordance with MIL-PRF-38535, appendix A.

4.2 Screening. For device classes Q and V, screening shall be in accordance with MIL-PRF-38535, and shall be conducted on all devices prior to qualification and technology conformance inspection. For device class M, screening shall be in accordance with method 5004 of MIL-STD-883, and shall be conducted on all devices prior to quality conformance inspection.

4.2.1 Additional criteria for device class M.

- a. Burn-in test, method 1015 of MIL-STD-883.
 - (1) Test condition A, B, C, or D. The test circuit shall be maintained by the manufacturer under document revision level control and shall be made available to the preparing or acquiring activity upon request. The test circuit shall specify the inputs, outputs, biases, and power dissipation, as applicable, in accordance with the intent specified in method 1015 of MIL-STD-883.
 - (2) $T_A = +125^{\circ}\text{C}$, minimum.
- b. Interim and final electrical test parameters shall be as specified in table II herein.

4.2.2 Additional criteria for device classes Q and V.

- a. The burn-in test duration, test condition and test temperature, or approved alternatives shall be as specified in the device manufacturer's QM plan in accordance with MIL-PRF-38535. The burn-in test circuit shall be maintained under document revision level control of the device manufacturer's Technology Review Board (TRB) in accordance with MIL-PRF-38535 and shall be made available to the acquiring or preparing activity upon request. The test circuit shall specify the inputs, outputs, biases, and power dissipation, as applicable, in accordance with the intent specified in method 1015 of MIL-STD-883.
- b. Interim and final electrical test parameters shall be as specified in table II herein.
- c. Additional screening for device class V beyond the requirements of device class Q shall be as specified in MIL-PRF-38535, appendix B.

4.3 Qualification inspection for device classes Q and V. Qualification inspection for device classes Q and V shall be in accordance with MIL-PRF-38535. Inspections to be performed shall be those specified in MIL-PRF-38535 and herein for groups A, B, C, D, and E inspections (see 4.4.1 through 4.4.4).

4.4 Conformance inspection. Technology conformance inspection for classes Q and V shall be in accordance with MIL-PRF-38535 including groups A, B, C, D, and E inspections, and as specified herein. Quality conformance inspection for device class M shall be in accordance with MIL-PRF-38535, appendix A and as specified herein. Inspections to be performed for device class M shall be those specified in method 5005 of MIL-STD-883 and herein for groups A, B, C, D, and E inspections (see 4.4.1 through 4.4.4).

4.4.1 Group A inspection.

- a. Tests shall be as specified in table II herein.
- b. Ground and V_{CC} bounce tests are required for all device classes. These tests shall be performed only for initial qualification, after process or design changes which may affect the performance of the device, and any changes to the test fixture. V_{OLP} , V_{OLV} , V_{OHP} , and V_{OHV} shall be measured for the worst case outputs of the device. All other outputs shall be guaranteed, if not tested, to the limits established for the worst case outputs. The worst case outputs tested are to be determined by the manufacturer. Test 5 devices assembled in the worst case package type supplied to this document. All other package types shall be guaranteed, if not tested, to the limits established for the worst case package. The package type to be tested shall be determined by the manufacturer. The device manufacturer will submit to DLA Land and Maritime-VA data that shall include all measured peak values for each device tested and detailed oscilloscope plots for each V_{OLP} , V_{OLV} , V_{OHP} , and V_{OHV} from one sample part per function. The plot shall contain the waveforms of both a switching output and the output under test.

STANDARD MICROCIRCUIT DRAWING DLA LAND AND MARITIME COLUMBUS, OHIO 43218-3990	SIZE A		5962-92215
		REVISION LEVEL G	SHEET 15

Each device manufacturer shall test product on the fixtures they currently use. When a new fixture is used, the device manufacturer shall inform DLA Land and Maritime-VA of this change and test the 5 devices on both the new and old test fixtures. The device manufacturer shall then submit to DLA Land and Maritime-VA data from testing on both fixtures that shall include all measured peak values for each device tested and detailed oscilloscope plots for each V_{OLP} , V_{OLV} , V_{OHP} , and V_{OHV} from one sample part per function. The plot shall contain the waveforms of both a switching output and the output under test.

- c. C_{IN} and C_{OUT} shall be measured only for initial qualification and after process or design changes which may affect capacitance. C_{IN} and C_{OUT} shall be measured between the designated terminal and GND at a frequency of 1 MHz. For C_{IN} and C_{OUT} , test all applicable pins on five devices with zero failures.
- d. For device class M, subgroups 7 and 8 tests shall be sufficient to verify the truth table in figure 2 herein. The test vectors used to verify the truth table shall, at a minimum, test all functions of each input and output. All possible input to output logic patterns per function shall be guaranteed, if not tested, to the truth table in figure 2, herein. For device classes Q and V, subgroups 7 and 8 shall include verifying the functionality of the device.

TABLE II. Electrical test requirements.

Test requirements	Subgroups (in accordance with MIL-STD-883, method 5005, table I)	Subgroups (in accordance with MIL-PRF-38535, table III)	
	Device class M	Device class Q	Device class V
Interim electrical parameters (see 4.2)	---	1	1
Final electrical parameters (see 4.2)	1/ 1, 2, 3, 4, 5, 6, 7, 8, 9, 10, 11	1/ 1, 2, 3, 4, 5, 6, 7, 8, 9, 10, 11	2/ 1, 2, 3, 4, 5, 6, 7, 8, 9, 10, 11
Group A test requirements (see 4.4)	1, 2, 3, 4, 5, 6, 7, 8, 9, 10, 11	1, 2, 3, 4, 5, 6, 7, 8, 9, 10, 11	1, 2, 3, 4, 5, 6, 7, 8, 9, 10, 11
Group C end-point electrical parameters (see 4.4)	1, 2, 3, 4, 5, 6	1, 2, 3, 4, 5, 6	1, 2, 3, 4, 5, 6, 7, 8, 9, 10, 11
Group D end-point electrical parameters (see 4.4)	1, 2, 3	1, 2, 3	1, 2, 3
Group E end-point electrical parameters (see 4.4)	1, 4, 7, 9	1, 4, 7, 9	1, 4, 7, 9

1/ PDA applies to subgroup 1.

2/ PDA applies to subgroups 1 and 7.

4.4.2 Group C inspection. The group C inspection end-point electrical parameters shall be as specified in table II herein.

4.4.2.1 Additional criteria for device class M. Steady-state life test conditions, method 1005 of MIL-STD-883:

- a. Test condition A, B, C, or D. The test circuit shall be maintained by the manufacturer under document revision level control and shall be made available to the preparing or acquiring activity upon request. The test circuit shall specify the inputs, outputs, biases, and power dissipation, as applicable, in accordance with the intent specified in method 1005 of MIL-STD-883.
- b. $T_A = +125^\circ\text{C}$, minimum.
- c. Test duration: 1,000 hours, except as permitted by method 1005 of MIL-STD-883.

STANDARD MICROCIRCUIT DRAWING DLA LAND AND MARITIME COLUMBUS, OHIO 43218-3990	SIZE A		5962-92215
		REVISION LEVEL G	SHEET 16

4.4.2.2 Additional criteria for device classes Q and V. The steady-state life test duration, test condition and test temperature, or approved alternatives shall be as specified in the device manufacturer's QM plan in accordance with MIL-PRF-38535. The test circuit shall be maintained under document revision level control by the device manufacturer's TRB in accordance with MIL-PRF-38535 and shall be made available to the acquiring or preparing activity upon request. The test circuit shall specify the inputs, outputs, biases, and power dissipation, as applicable, in accordance with the intent specified in method 1005 of MIL-STD-883.

4.4.3 Group D inspection. The group D inspection end-point electrical parameters shall be as specified in table II herein.

4.4.4 Group E inspection. Group E inspection is required only for parts intended to be marked as radiation hardness assured (see 3.5 herein).

- a. End-point electrical parameters shall be as specified in table II herein.
- b. For device classes Q and V, the devices or test vehicle shall be subjected to radiation hardness assured tests as specified in MIL-PRF-38535 for the RHA level being tested. For device class M, the devices shall be subjected to radiation hardness assured tests as specified in MIL-PRF-38535, appendix A for the RHA level being tested. All device classes must meet the postirradiation end-point electrical parameter limits as defined in table I at $T_A = +25^{\circ}\text{C}$ to $+55^{\circ}\text{C}$, after exposure, to the subgroups specified in table II herein.

5. PACKAGING

5.1 Packaging requirements. The requirements for packaging shall be in accordance with MIL-PRF-38535 for device classes Q and V or MIL-PRF-38535, appendix A for device class M.

6. NOTES

6.1 Intended use. Microcircuits conforming to this drawing are intended for use for Government microcircuit applications (original equipment), design applications, and logistics purposes.

6.1.1 Replaceability. Microcircuits covered by this drawing will replace the same generic device covered by a contractor prepared specification or drawing.

6.1.2 Substitutability. Device class Q devices will replace device class M devices.

6.2 Configuration control of SMD's. All proposed changes to existing SMD's will be coordinated with the users of record for the individual documents. This coordination will be accomplished using DD Form 1692, Engineering Change Proposal, or email communication.

6.3 Record of users. Military and industrial users should inform DLA Land and Maritime when a system application requires configuration control and which SMD's are applicable to that system. DLA Land and Maritime will maintain a record of users and this list will be used for coordination and distribution of changes to the drawings. Users of drawings covering microelectronic devices (FSC 5962) should contact DLA Land and Maritime-VA, telephone (614) 692-8108.

6.4 Comments. Comments on this drawing should be directed to DLA Land and Maritime-VA, Columbus, Ohio 43218-3990, or telephone (614) 692-0591.

6.5 Abbreviations, symbols, and definitions. The abbreviations, symbols, and definitions used herein are defined in MIL-PRF-38535 and MIL-HDBK-1331.

6.6 Sources of supply.

6.6.1 Sources of supply for device classes Q and V. Sources of supply for device classes Q and V are listed in MIL-HDBK-103 and QML-38535. The vendors listed in QML-38535 have submitted a certificate of compliance (see 3.6 herein) to DLA Land and Maritime-VA and have agreed to this drawing.

6.6.2 Approved sources of supply for device class M. Approved sources of supply for class M are listed in MIL-HDBK-103. The vendors listed in MIL-HDBK-103 have agreed to this drawing and a certificate of compliance (see 3.6 herein) has been submitted to and accepted by DLA Land and Maritime-VA.

STANDARD MICROCIRCUIT DRAWING DLA LAND AND MARITIME COLUMBUS, OHIO 43218-3990	SIZE A		5962-92215
		REVISION LEVEL G	SHEET 17

STANDARD MICROCIRCUIT DRAWING BULLETIN

DATE: 23-02-21

Approved sources of supply for SMD 5962-92215 are listed below for immediate acquisition information only and shall be added to MIL-HDBK-103 and QML-38535 during the next revision. MIL-HDBK-103 and QML-38535 will be revised to include the addition or deletion of sources. The vendors listed below have agreed to this drawing and a certificate of compliance has been submitted to and accepted by DLA Land and Maritime-VA. This information bulletin is superseded by the next dated revision of MIL-HDBK-103 and QML-38535. DLA Land and Maritime maintains an online database of all current sources of supply at <https://landandmaritimeapps.dla.mil/programs/smcr>.

Standard microcircuit drawing PIN <u>1</u> /	Vendor CAGE number	Vendor similar PIN <u>2</u> /
5962-9221501M2A	0C7V7	IDT54FCT273TLB
	3DTT2	P54FCT273TLMB
5962-9221501MRA	0C7V7	IDT54FCT273TDB
	3DTT2	P54FCT273TCMB
5962-9221501MSA	0C7V7	IDT54FCT273TEB
	3DTT2	P54FCT273TFSMB
5962-9221502M2A	<u>3</u> /	54FCT273AT
	3DTT2	P54FCT273TLMB
5962-9221502MRA	<u>3</u> /	54FCT273AT
	3DTT2	P54FCT273TCMB
5962-9221502MSA	3DTT2	P54FCT273TFSMB
5962-9221503M2A	0C7V7	IDT54FCT273ATLB
	01295	CY54FCT273ATLMB
	3DTT2	P54FCT273ATLMB
5962-9221503MRA	0C7V7	IDT54FCT273ATDB
	01295	CY54FCT273ATDMB
	3DTT2	P54FCT273ATCMB
5962-9221503MSA	0C7V7	IDT54FCT273ATEB
	3DTT2	P54FCT273ATFSMB
5962-9221504M2A	<u>3</u> /	54FCT273AT
	3DTT2	P54FCT273ATLMB
5962-9221504MRA	<u>3</u> /	54FCT273AT
	3DTT2	P54FCT273ATCMB
5962-9221504MSA	3DTT2	P54FCT273ATFSMB
5962-9221505M2A	0C7V7	IDT54FCT273CTLB
	3DTT2	P54FCT273CTLMB
5962-9221505MRA	0C7V7	IDT54FCT273CTDB
	3DTT2	P54FCT273CTCMB
5962-9221505MSA	0C7V7	IDT54FCT273CTEB
	3DTT2	P54FCT273CTFSMB
5962-9221506M2A	<u>3</u> /	54FCT273CT
	3DTT2	P54FCT273CTLMB
5962-9221506MRA	<u>3</u> /	54FCT273CT
	3DTT2	P54FCT273CTCMB
5962-9221506MSA	3DTT2	P54FCT273CTFSMB

STANDARD MICROCIRCUIT DRAWING BULLETIN – Continued.

DATE: 23-02-21

- 1/ The lead finish shown for each PIN representing a hermetic package is the most readily available from the manufacturer listed for that part. If the desired lead finish is not listed contact the vendor to determine its availability.
- 2/ Caution. Do not use this number for item acquisition. Items acquired to this number may not satisfy the performance requirements of this drawing.
- 3/ Not available from an approved source of supply.

<u>Vendor CAGE number</u>	<u>Vendor name and address</u>
01295	Texas Instruments Inc. Semiconductor Group 8505 Forest Ln. P.O. Box 660199 Dallas, TX 75243
0C7V7	Teledyne e2v, Inc. 765 Sycamore Drive Milpitas, CA 95035
3DTT2	Pyramid Semiconductor 1249 Reamwood Avenue Sunnyvale, CA 94089, USA

The information contained herein is disseminated for convenience only and the Government assumes no liability whatsoever for any inaccuracies in the information bulletin.