

## PI2DDR3212

## 1.35V/1.5V/1.8V 14 bit 2:1 DDR3/DDR4 Switch

## Features

- 14 bit 2:1 switch that supports DDR3 800 2133Mbps, DDR4 1600~4266 Mbps
- VDD 1.35V/ 1.5V/ 1.8V
- Flow through pinout option for easy layout
- SEL and Global Enable
- 110  $\mu$ A typ. operating current at 1.35V VDD.
- High impedance and low Coff channel output when disabled or deselected
- Low  $R_{ON}$ : 8 $\Omega$  typical
- 3dB Bandwidth: 3.3GHz
- Low insertion loss: -0.7dB ( $0 \leq f \leq 1$  GHz)
- Low return loss: -23dB ( $0 \leq f \leq 1$  GHz)
- Low cross-talk for high speed channels: -25dB typ. ( $0 < f < 2$ GHz)
- Low off-isolation: -28dB ( $0 \leq f \leq 1$  GHz)
- Low bit-to-bit skew 20ps Max
- ESD: 2KV HBM
- POD\_12, SSTL\_12, SSTL\_135, SSTL\_15 or SSTL\_18 signaling
- Totally Lead-Free & Fully RoHS Compliant (Notes 1 & 2)
- Halogen and Antimony Free. "Green" Device (Note 3)
- For automotive applications requiring specific change control (i.e. parts qualified to AEC-Q100/101/200, PPAP capable, and manufactured in IATF 16949 certified facilities), please [contact us](mailto:contact@diodes.com) or your local Diodes representative. <https://www.diodes.com/quality/product-definitions/>
- Packaging (Pb-free and Green)
  - 52-pin, 3.5x9mm TQFN (ZL)
  - 48-pin, 4.5x4.5mm TFBGA (NC) pin compatible with CBTW28DD14

## Application

- DDR3/DDR4 Memory Bus System
- NVDIMM Module
- Flash Memory Array sub system
- High Speed multiplexing

## Description

This 14-bit DDR3/DDR4 switch is designed for 1.35V/1.5V/1.8V supply voltage, POD\_12, SSTL\_135, SSTL\_15 or SSTL\_18 signaling and CMOS select input signals. It is designed for DDR3 or DDR4 memory bus with speed up to 5Gbps. It supports DDR3 800 2133Mbps and DDR4 1600~4266 Mbps.

PI2DDR3212 has a 1:2 demux or 2:1 mux topology. All 14-bit channels can be switched to one of the two ports simultaneously with the SEL input. This device also allows all ports to be disconnected.

PI2DDR3212 uses Diodes' proprietary high speed switch technology providing consistent high bandwidth across all channels, with very little insertion loss, cross-talk, and bit to bit skew.

It is available in a 52-pin TQFN 3.5x9mm package and 48-pin TFBGA 4.5x4.5mm package. The 48-pin version is pin compatible with CBTW28DD14.

## Block Diagram

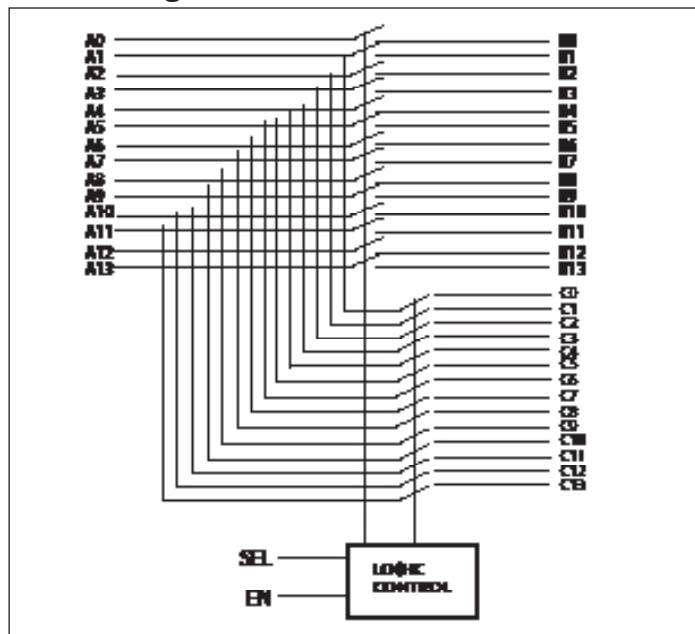

### Notes:

1. No purposely added lead. Fully EU Directive 2002/95/EC (RoHS), 2011/65/EU (RoHS 2) & 2015/863/EU (RoHS 3) compliant.
2. See <https://www.diodes.com/quality/lead-free/> for more information about Diodes Incorporated's definitions of Halogen- and Antimony-free, "Green" and Lead-free.
3. Halogen- and Antimony-free "Green" products are defined as those which contain <900ppm bromine, <900ppm chlorine (<1500ppm total Br + Cl) and <1000ppm antimony compounds.

**Pin Configuration (48-TFBGA )**

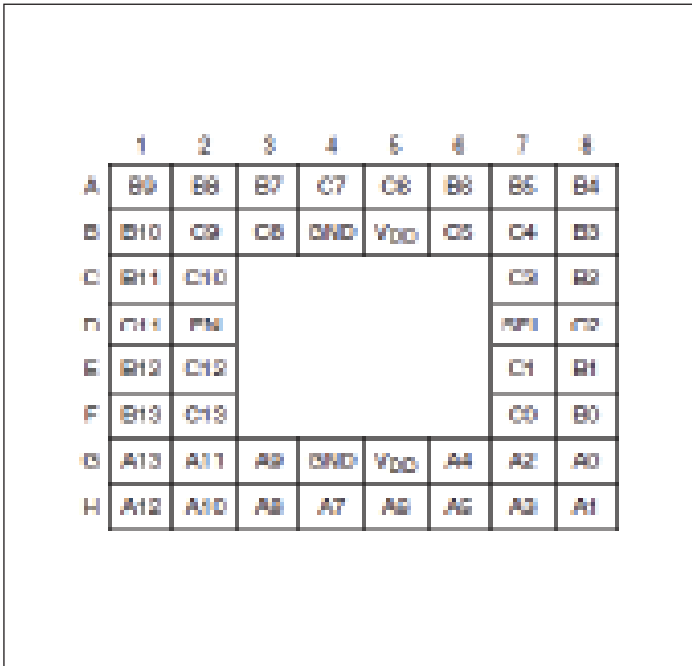

**Pin Configuration (52-TQFN)**

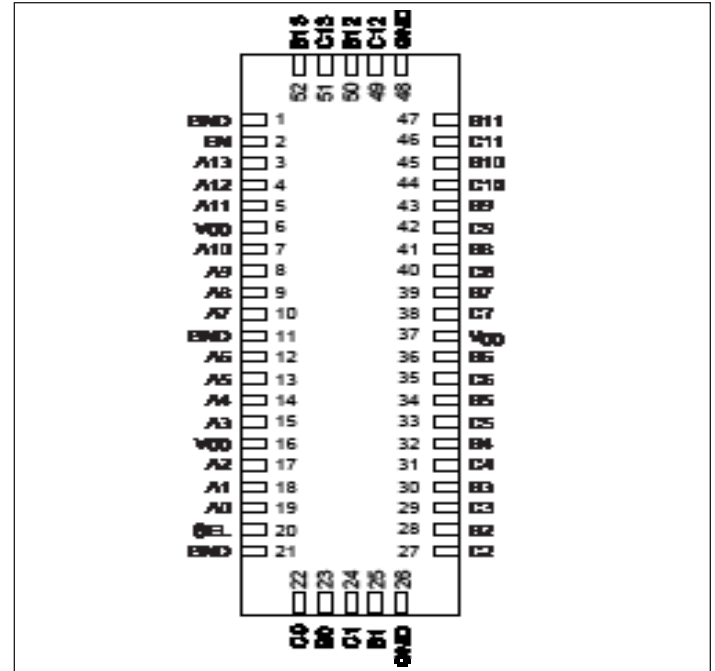

**Pin Description**

Pin Name	IO Type	Descriptions
VDD	Power	1.35V, 1.5V or 1.8V power supply.
GND	Ground	1.35V, Ground connection
A[0:13]	I/O	14-bit wide input/output, port A
B[0:13]	I/O	14-bit wide input/output, port B
C[0:13]	I/O	14-bit wide input/output, port C
SEL	I	CMOS input for channel selection
EN	I	CMOS input When HIGH, connection is set using the SEL input signal When LOW, all ports are mutually isolated

**Truth Table (SEL)**

SEL	Function
0	Output B is selected
1	Output C is selected

**Truth Table (EN)**

EN	Function
1	Global Enable
0	Global Disable

### Maximum Ratings

(Above which useful life may be impaired. For user guidelines, not tested.)

Supply Voltage to Ground Potential .....	-0.3V to 2.5V
All Inputs.....	-0.3V to $V_{DD}+0.3V$
Ambient Operating Temperature .....	-10 to +85°C
Storage Temperature.....	-65 to +150°C
Junction Temperature .....	150°C
Soldering Temperature.....	260°C

**Note:**

Stresses greater than those listed under MAXIMUM RATINGS may cause permanent damage to the device. This is a stress rating only and functional operation of the device at these or any other conditions above those indicated in the operational sections of this specification is not implied. Exposure to absolute maximum rating conditions for extended periods may affect reliability.

### Recommended Operation Conditions

Parameter	Min.	Typ.	Max.	Unit
Ambient Operating Temperature	-10		+85	°C
Power Supply Voltage (measured in respect to GND)	+1.28	1.8	+2.0	V

### Static Characteristics

Symbol	Parameter	Conditions	Min.	Typ.	Max.	Unit
$V_{DD}$	Supply Voltage		1.28	1.35/ 1.5/1.8	2	V
$I_{DD}$	$V_{DD}$ Supply Current	EN= HIGH; $V_{DD}=1.8V$		220	350	$\mu A$
		EN= LOW; $V_{DD}=1.8V$		0.1	10	$\mu A$
$I_{DD}$	$V_{DD}$ Supply Current	EN= HIGH; $V_{DD}=1.35V$		110	200	$\mu A$
		EN= LOW; $V_{DD}=1.35V$		0.05	2	$\mu A$
<b>Control Pin (SEL, EN)</b>						
$I_{IH}$	High level digital input current	$V_{IH}=V_{DD}$ , $V_{DD}=2.0V$			5	$\mu A$
$I_{IL}$	Low level digital input current	$V_{IL} = GND$ , $V_{DD}=2.0V$			5	$\mu A$
$V_{IH}$	High level digital input voltage		$0.8 * V_{DD}$			V
$V_{IL}$	Low level digital input voltage				$0.2 * V_{DD}$	V
<b>I/O Pin (A, B ,C)</b>						
$C_{OFF}$	Switch OFF capacitance	$f = 1MHz$ ; $V_{I/O} = 0V$		1.1		pF
$C_{ON}$	Switch ON capacitance	$f = 1MHz$ ; $V_{I/O} = 0V$		2.1		pF

**Dynamic Characteristics** (over recommended operating conditions unless otherwise noted)

Symbol	Parameter	Test Conditions	Min.	Typ. <sup>(1)</sup>	Max.	Units
tstartup	Startup time	Supply voltage valid or EN going HIGH to channels specified characteristics		5	10	μs
trcfg	Reconfiguration time	SEL state change to channel specified operating characteristics		0.02	0.04	
tpd	Propagation delay	From A port to B port or C port or vice versa		60		ps
tsk	Skew time	From any output to any output		18	20	ps
V <sub>I</sub>	Input Voltage		-0.3		V <sub>dd</sub> +0.3	V
B	Bandwidth	-3dB intercept		3.3		GHz
C	Crosstalk attenuation	Adjacent channels are on; 0 ≤ f ≤ 1GHz		-26		dB
I <sub>L</sub>	Insertion Loss	0 ≤ f ≤ 1GHz		-0.7		dB
		f = 2.5GHz		-2.5		dB
R <sub>L</sub>	Input Return Loss	0 ≤ f ≤ 1GHz		-23		dB
OI	Off Isolation	0 ≤ f ≤ 1 GHz		-28		dB

**Application Diagram**

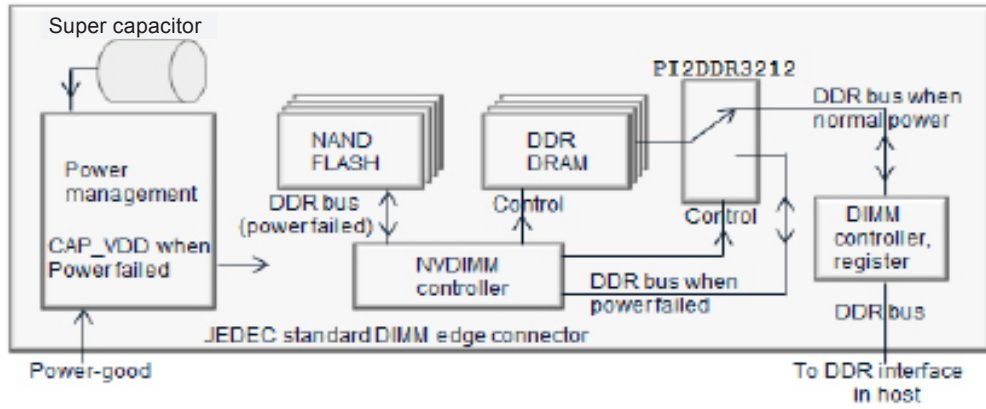

NVDIMM Application using PI2DDR3212

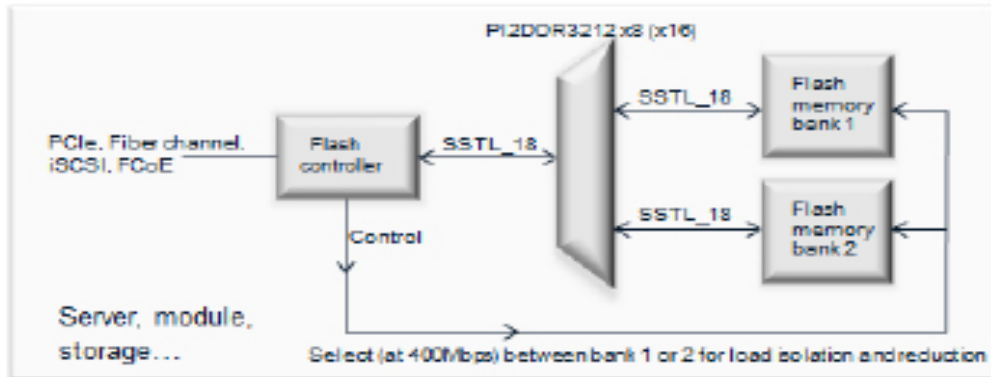

SSD, Flash Storage Application using PI2DDR3212

**PI2DDR3212**

**Part Marking**

ZL Package

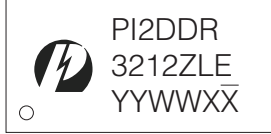

YY: Year  
WW: Workweek  
1st X: Assembly Code  
2nd X: Fab Code

NC Package

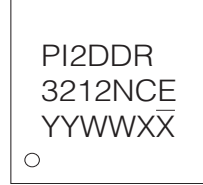

YY: Year  
WW: Workweek  
1st X: Assembly Code  
2nd X: Fab Code  
Bar above fab code means Cu wire

**PI2DDR3212**

**Packaging Mechanical: 48-TFBGA (NC)**

	SYMBOL	COMMON DIMENSIONS		
		MIN.	NOR.	MAX.
TOTAL THICKNESS	A	---	---	1.10
STAND OFF	A1	0.16	---	0.26
SUBSTRATE THICKNESS	A2	0.21		REF
MOLD THICKNESS	A3	0.54		REF
BODY SIZE	D	4.40	4.50	4.60
	E	4.40	4.50	4.60
BALL DIAMETER		0.30		
BALL OPENING		0.275		
BALL WIDTH	b	0.27	---	0.37
BALL PITCH	e	0.50		BSC
BALL COUNT	n	48		
EDGE BALL CENTER TO CENTER	D1	3.50		BSC
	E1	3.50		BSC
BODY CENTER TO CONTACT BALL	SD	0.25		BSC
	SE	0.25		BSC
PACKAGE EDGE TOLERANCE	aaa	0.1		
MOLD FLATNESS	bbb	0.1		
COPLANARITY	ddd	0.08		
BALL OFFSET (PACKAGE)	eee	0.15		
BALL OFFSET (BALL)	fff	0.08		

RECOMMENDED LAND PATTERN (not to scale)

**PERICOM**  
Enabling Serial Connectivity

DATE: 04/25/14

DESCRIPTION: 48-Ball, Thin Fine Pitch Ball Grid Array, TFBGA

PACKAGE CODE: NC (NC48)

DOCUMENT CONTROL #: PD-2103

REVISION: A

NOTE :  
 1. ALL DIMENSIONS ARE IN mm. ANGLES IN DEGREES.  
 2. REFER JEDEC MO-195.  
 3. RECOMMENDED LAND PATTERN IS FOR REFERENCE ONLY.

14-0123

**Packaging Mechanical: 52-TQFN (ZL)**

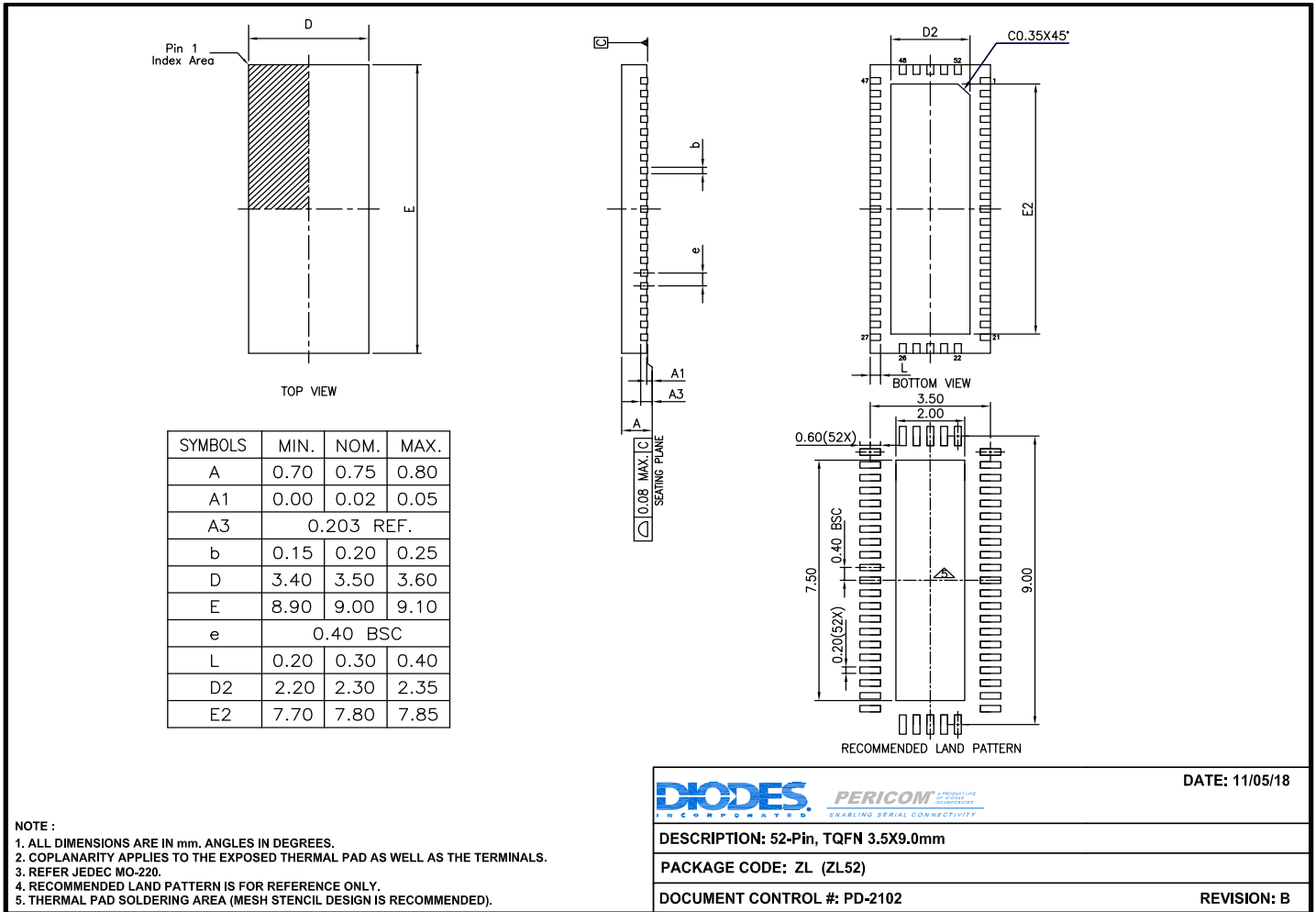

For latest package info.

please check: <http://www.diodes.com/design/support/packaging/pericom-packaging/packaging-mechanicals-and-thermal-characteristics/>

**Ordering Information**

Ordering Code	Packaging Code	Package Description
PI2DDR3212ZLEX	ZL	52-Pin, Thin Quad Flat No-Lead (TQFN)
PI2DDR3212NCEX	NC	48-Pin, Thin Fine Pitch Ball Grid Array (TFBGA)

**Notes:**

1. No purposely added lead. Fully EU Directive 2002/95/EC (RoHS), 2011/65/EU (RoHS 2) & 2015/863/EU (RoHS 3) compliant.
2. See <https://www.diodes.com/quality/lead-free/> for more information about Diodes Incorporated's definitions of Halogen- and Antimony-free, "Green" and Lead-free.
3. Halogen- and Antimony-free "Green" products are defined as those which contain <900ppm bromine, <900ppm chlorine (<1500ppm total Br + Cl) and <1000ppm antimony compounds.
4. E = Pb-free and Green
5. X suffix = Tape/Reel



**IMPORTANT NOTICE**

1. DIODES INCORPORATED (Diodes) AND ITS SUBSIDIARIES MAKE NO WARRANTY OF ANY KIND, EXPRESS OR IMPLIED, WITH REGARDS TO ANY INFORMATION CONTAINED IN THIS DOCUMENT, INCLUDING, BUT NOT LIMITED TO, THE IMPLIED WARRANTIES OF MERCHANTABILITY, FITNESS FOR A PARTICULAR PURPOSE OR NON-INFRINGEMENT OF THIRD PARTY INTELLECTUAL PROPERTY RIGHTS (AND THEIR EQUIVALENTS UNDER THE LAWS OF ANY JURISDICTION).
2. The Information contained herein is for informational purpose only and is provided only to illustrate the operation of Diodes' products described herein and application examples. Diodes does not assume any liability arising out of the application or use of this document or any product described herein. This document is intended for skilled and technically trained engineering customers and users who design with Diodes' products. Diodes' products may be used to facilitate safety-related applications; however, in all instances customers and users are responsible for (a) selecting the appropriate Diodes products for their applications, (b) evaluating the suitability of Diodes' products for their intended applications, (c) ensuring their applications, which incorporate Diodes' products, comply the applicable legal and regulatory requirements as well as safety and functional-safety related standards, and (d) ensuring they design with appropriate safeguards (including testing, validation, quality control techniques, redundancy, malfunction prevention, and appropriate treatment for aging degradation) to minimize the risks associated with their applications.
3. Diodes assumes no liability for any application-related information, support, assistance or feedback that may be provided by Diodes from time to time. Any customer or user of this document or products described herein will assume all risks and liabilities associated with such use, and will hold Diodes and all companies whose products are represented herein or on Diodes' websites, harmless against all damages and liabilities.
4. Products described herein may be covered by one or more United States, international or foreign patents and pending patent applications. Product names and markings noted herein may also be covered by one or more United States, international or foreign trademarks and trademark applications. Diodes does not convey any license under any of its intellectual property rights or the rights of any third parties (including third parties whose products and services may be described in this document or on Diodes' website) under this document.
5. Diodes' products are provided subject to Diodes' Standard Terms and Conditions of Sale (<https://www.diodes.com/about/company/terms-and-conditions/terms-and-conditions-of-sales/>) or other applicable terms. This document does not alter or expand the applicable warranties provided by Diodes. Diodes does not warrant or accept any liability whatsoever in respect of any products purchased through unauthorized sales channel.
6. Diodes' products and technology may not be used for or incorporated into any products or systems whose manufacture, use or sale is prohibited under any applicable laws and regulations. Should customers or users use Diodes' products in contravention of any applicable laws or regulations, or for any unintended or unauthorized application, customers and users will (a) be solely responsible for any damages, losses or penalties arising in connection therewith or as a result thereof, and (b) indemnify and hold Diodes and its representatives and agents harmless against any and all claims, damages, expenses, and attorney fees arising out of, directly or indirectly, any claim relating to any noncompliance with the applicable laws and regulations, as well as any unintended or unauthorized application.
7. While efforts have been made to ensure the information contained in this document is accurate, complete and current, it may contain technical inaccuracies, omissions and typographical errors. Diodes does not warrant that information contained in this document is error-free and Diodes is under no obligation to update or otherwise correct this information. Notwithstanding the foregoing, Diodes reserves the right to make modifications, enhancements, improvements, corrections or other changes without further notice to this document and any product described herein. This document is written in English but may be translated into multiple languages for reference. Only the English version of this document is the final and determinative format released by Diodes.
8. Any unauthorized copying, modification, distribution, transmission, display or other use of this document (or any portion hereof) is prohibited. Diodes assumes no responsibility for any losses incurred by the customers or users or any third parties arising from any such unauthorized use.
9. This Notice may be periodically updated with the most recent version available at <https://www.diodes.com/about/company/terms-and-conditions/important-notice>

The Diodes logo is a registered trademark of Diodes Incorporated in the United States and other countries.  
All other trademarks are the property of their respective owners.  
© 2023 Diodes Incorporated. All Rights Reserved.

[www.diodes.com](http://www.diodes.com)