

RapidCharge™ AC/DC Primary-Side Digital Quasi-Resonant Flyback Controller for Secondary-Side Regulation

1 Description

The iW9809 is a high-performance AC/DC primary-side digital flyback controller with adaptive multi-mode-control (MMC) working with secondary-side regulation (SSR) for applications requiring high resolution in output voltage/current setting. The device can support rapid charge applications such as travel adapters (TA) of 25W (5V/3A, 9V/2.77A, etc.). It operates in quasi-resonant switching mode and supports optional continuous conduction mode (CCM) for low line voltage and it uses multi-mode control (MMC) including PWM, PFM and burst mode to achieve less power loss and low EMI. It also provides a number of key built-in protection features. The iW9809 is optimized to work with Dialog's secondary-side controller, the iW70x, for SSR, synchronous rectifier (SR) control and USB PD 3.0 w/PPS protocol support. The iW9809/iW70x chipset can achieve tight multi-level constant voltage (CV) and multi-level constant current (CC) regulation in very fine steps for rapid charge applications. With SSR digital compensation, the chipset eliminates the need for external loop compensation components while maintaining stability under all operating conditions.

The iW9809 and iW70x chipset can support USB PD to achieve fast and smooth CV/CC transitions upon request by mobile devices (MD). The iW9809 and iW70x chipset can meet no-load power consumption of less than 20mW for a typical 25W design when output USB cable is detached.

Dialog's innovative proprietary technology ensures that power supplies designed with the iW9809 and iW70x chipset can achieve high efficiency, high accuracy voltage/current control and fast dynamic load response.

2 Features

- Supports Rapid Charge adapters applications of typical 25W and other power profiles
- Supports constant-voltage (CV) and constant-current (CC) regulation in fine steps using secondary-side regulation (SSR) control
- Proprietary constant-frequency switching with quasi-resonant (QR) operation achieves best size, efficiency and common mode noise
- Adaptive QR mode and optional continuous conduction mode (CCM) operation at low line voltage
- Adaptive multi-mode control (MMC) using PWM/ PFM/Burst modes based on input voltage and output voltage/current improves efficiency and eliminates audible noise
- Built-in single-point fault protections against AC line voltage brown-out, output short-circuit, output over-voltage, and optocoupler failure
- User programable internal OTP threshold for various thermal requirement
- < 20mW no load standby power with ample margin at 230V_{AC} when output USB cable is detached.
- 8-lead SOIC package

3 Applications

- Rapid-charging AC/DC adapters for smart phones, tablets and other portable devices

RapidCharge™ AC/DC Primary-Side Digital Quasi-Resonant Flyback Controller for Secondary-Side Regulation

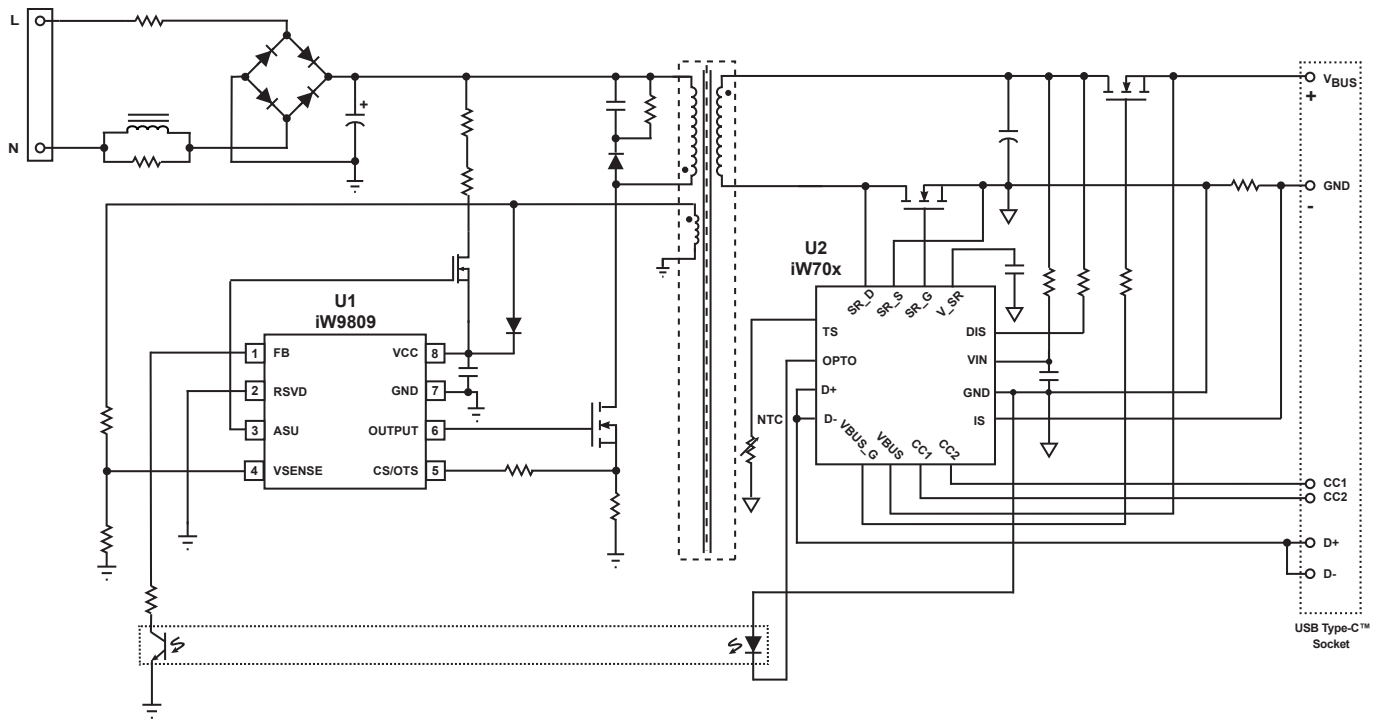

Figure 3.1 : iW9809 Typical Application Circuit with Active Start-up Circuit (Using iW70x as Secondary-Side Controller. Achieving Multi-Level CV/CC Regulation)

RapidCharge™ AC/DC Primary-Side Digital Quasi-Resonant Flyback Controller for Secondary-Side Regulation

4 Pinout Description

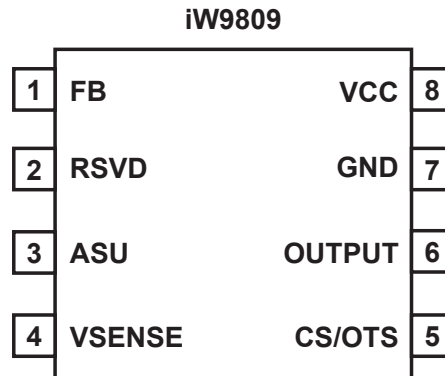

Figure 4.1 : 8-Lead SOIC Package

Pin Number	Pin Name	Type	Pin Description
1	FB	Analog Input	Feedback voltage. Used for determining multi-mode control and cycle-by-cycle peak current control.
2	RSVD	Reserved	Reserved. It is recommended that this pin be connected to GND.
3	ASU	Analog Output	Control Signal. Used for active start-up device (BJT or depletion mode N-FET).
4	VSENSE	Analog Input	Voltage sensing. Used output voltage sensing and auxiliary winding ringing voltage sensing.
5	CS/OTS	Analog Input	Current sensing. Used for cycle-by-cycle peak-current control and limit. During configuration stage, it can be used to configure certain parameters, such as internal over-temperature protection setting.
6	OUTPUT	Analog Output	Gate drive for power MOSFET.
7	GND	Ground	Ground.
8	VCC	Power Input	IC power supply.

RapidCharge™ AC/DC Primary-Side Digital Quasi-Resonant Flyback Controller for Secondary-Side Regulation

5 Absolute Maximum Ratings

Absolute maximum ratings are the parameter values or ranges which can cause permanent damage if exceeded.

Parameter	Symbol	Value	Units
DC supply voltage range	V_{VCC}	-0.3 to 45	V
Continuous DC supply current at VCC pin ($V_{VCC} = 15V$)	I_{VCC}	20	mA
VSENSE input ($I_{VSENSE} \leq 10mA$)		-0.7 to 10	V
FB voltage		-0.3 to 5.0	V
ASU voltage		-0.3 to 45	V
CS/OTS voltage		-0.3 to 5.5	V
OUTPUT voltage		-0.3 to 20	V
Maximum junction temperature	T_{JMAX}	150	°C
Operating junction temperature	T_{JOPT}	-40 to 150	°C
Storage temperature	T_{STO}	-65 to 150	°C
Thermal Resistance Junction-to-Ambient	θ_{JA}	160	°C/W
ESD rating per JEDEC JS-001-2017		$\pm 2,000$	V
Latch-up test per JESD78E		± 100	mA

Notes:

Note 1. Stresses beyond those listed under Absolute Maximum Ratings may cause permanent damage to the device. These are stress ratings only, so functional operation of the device at these or any other conditions beyond those indicated in the operational sections of the specification are not implied. Exposure to absolute maximum rating conditions for extended periods may affect device reliability.

RapidCharge™ AC/DC Primary-Side Digital Quasi-Resonant Flyback Controller for Secondary-Side Regulation

6 Physical Dimensions

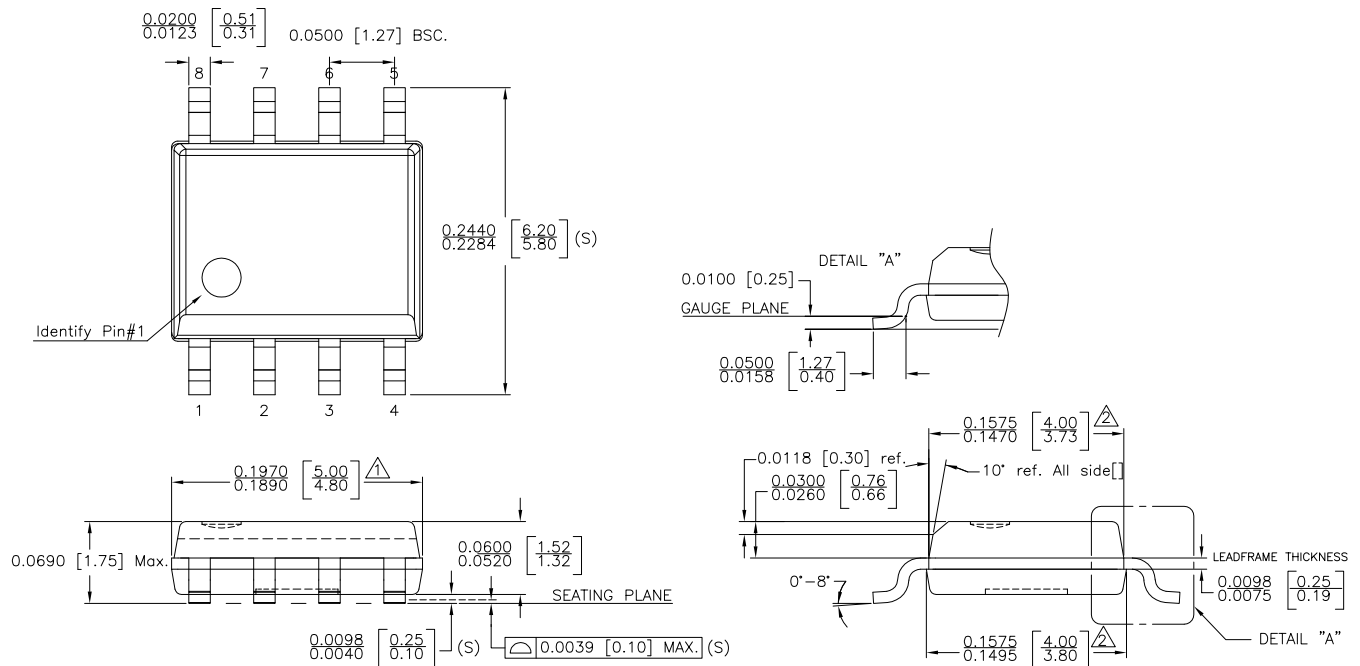

NOTE :

- △ DOES NOT INCLUDE MOLD FLASH, PROTRUSIONS OR GATE BURRS. MOLD FLASH, PROTRUSIONS AND GATE BURRS SHALL NOT EXCEED .006 INCH PER SIDE.
- △ DOES NOT INCLUDE INTER-LEAD FLASH OR PROTRUSIONS. INTER-LEAD FLASH AND PROTRUSIONS SHALL NOT EXCEED .010 INCH PER SIDE.
- 3. THIS PART IS COMPLIANT WITH JEDEC SPECIFICATION MS-012.
- 4. LEAD SPAN/STAND OFF HEIGHT/COPLANARITY ARE CONSIDERED AS SPECIAL CHARACTERISTIC.(S)
- 5. CONTROLLING DIMENSIONS IN INCHES. [mm]

STATUS: RELEASED		SCALE: DO NOT SCALE
TERMINAL FINISH: 100% Sn or NiPdAu (PPF)		
TITLE: 8 SOIC PACKAGE OUTLINE		
REV: D	REVISION NOTE: EJECTOR CHANGED TO DASHED LINE	DATE: 18-JUN-2020

Figure 6.1 : 8-Lead SOIC package outline drawing

7 Ordering Information

Part no.	Options					Package	Description
	V _{BUS} range	CCM	F _{SW(MAX)} at low line	F _{SW(MAX)} at high line	V _{BUS} /V _{SENSE}		
iW9809-00	3.3V to 11V	Yes	70kHz	75kHz	5:1	SOIC-8	Tape & Reel ¹
iW9809-02	3.3V to 21V	Yes	90kHz	95kHz	5:0.7	SOIC-8	Tape & Reel ¹

Note 1: Tape & Reel packing quantity is 2,500/reel. Minimum packing quantity is 2,500.

RapidCharge™ AC/DC Primary-Side Digital Quasi-Resonant Flyback Controller for Secondary-Side Regulation

8 Top Marking

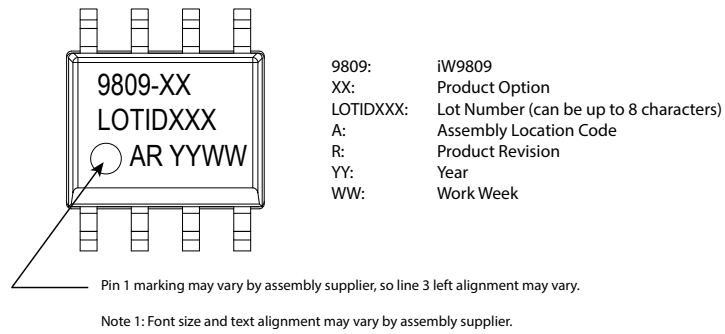

Figure 8.1 : Top Marking for the iW9809

RapidCharge™ AC/DC Primary-Side Digital Quasi-Resonant Flyback Controller for Secondary-Side Regulation

Disclaimer

Unless otherwise agreed in writing, the Dialog Semiconductor products (and any associated software) referred to in this document are not designed, authorized or warranted to be suitable for use in life support, life-critical or safety-critical systems or equipment, nor in applications where failure or malfunction of a Dialog Semiconductor product (or associated software) can reasonably be expected to result in personal injury, death or severe property or environmental damage. Dialog Semiconductor and its suppliers accept no liability for inclusion and/or use of Dialog Semiconductor products (and any associated software) in such equipment or applications and therefore such inclusion and/or use is at the customer's own risk.

Information in this document is believed to be accurate and reliable. However, Dialog Semiconductor does not give any representations or warranties, express or implied, as to the accuracy or completeness of such information. Dialog Semiconductor furthermore takes no responsibility whatsoever for the content in this document if provided by any information source outside of Dialog Semiconductor.

Dialog Semiconductor reserves the right to change without notice the information published in this document, including, without limitation, the specification and the design of the related semiconductor products, software and applications. Notwithstanding the foregoing, for any automotive grade version of the device, Dialog Semiconductor reserves the right to change the information published in this document, including, without limitation, the specification and the design of the related semiconductor products, software and applications, in accordance with its standard automotive change notification process.

Applications, software, and semiconductor products described in this document are for illustrative purposes only. Dialog Semiconductor makes no representation or warranty that such applications, software and semiconductor products will be suitable for the specified use without further testing or modification. Unless otherwise agreed in writing, such testing or modification is the sole responsibility of the customer and Dialog Semiconductor excludes all liability in this respect.

Nothing in this document may be construed as a license for customer to use the Dialog Semiconductor products, software and applications referred to in this document. Such license must be separately sought by customer with Dialog Semiconductor.

All use of Dialog Semiconductor products, software and applications referred to in this document is subject to Dialog Semiconductor's [Standard Terms and Conditions of Sale](#), available on the company website (www.dialog-semiconductor.com) unless otherwise stated.

Dialog, Dialog Semiconductor and the Dialog logo are trademarks of Dialog Semiconductor Plc or its subsidiaries. All other product or service names and marks are the property of their respective owners.

© 2021 Dialog Semiconductor. All rights reserved.

RoHS Compliance

Dialog Semiconductor's suppliers certify that its products are in compliance with the requirements of Directive 2011/65/EU of the European Parliament on the restriction of the use of certain hazardous substances in electrical and electronic equipment. RoHS certificates from our suppliers are available on request.

Contacting Dialog Semiconductor

United Kingdom (Headquarters)
Dialog Semiconductor (UK) LTD
Phone: +44 1793 757700

Germany
Dialog Semiconductor GmbH
Phone: +49 7021 805-0

The Netherlands
Dialog Semiconductor B.V.
Phone: +31 73 640 8822

Email
info_pcbg@diasemi.com

North America
Dialog Semiconductor Inc.
Phone: +1 408 845 8500

Japan
Dialog Semiconductor K. K.
Phone: +81 3 5769 5100

Taiwan
Dialog Semiconductor Taiwan
Phone: +886 281 786 222

Web site:
www.dialog-semiconductor.com

Hong Kong
Dialog Semiconductor Hong Kong
Phone: +852 2607 4271

Korea
Dialog Semiconductor Korea
Phone: +82 2 3469 8200

China (Shenzhen)
Dialog Semiconductor China
Phone: +86 755 2981 3669

China (Shanghai)
Dialog Semiconductor China
Phone: +86 21 5424 9058