

GreenPAK Programmable Mixed-Signal Matrix with Asynchronous State Machine and Dual Supply

General Description

The GPAK product family is based around Dialog Semiconductor's proprietary Zero Static Power ASM (Asynchronous State Machine). This machine is fault tolerant and operates continuously over a wide voltage range with very low latency. The SLG46880/81 provides a small, low power component for commonly used Mixed-Signal functions. The user creates their circuit design by programming the one time Non-Volatile Memory (NVM) to configure the interconnect logic, the IO Pins, and the macrocells of the SLG46880/81. This highly versatile device allows a wide variety of Mixed-Signal functions to be designed within a very small, low power single integrated circuit.

Key Features

- Two High Speed General Purpose Rail-to-Rail Analog Comparators (ACMPxH)
- Two Low Power General Purpose Rail-to-Rail Analog Comparators (ACMPxL)
- Two Voltage References
 - Two Vref Outputs
- Twelve Combination Function Macrocells
 - One Selectable DFF/LATCH or 2-bit LUT
 - Four Selectable DFF/LATCHES or 3-bit LUTs
 - One Selectable Pipe Delay or Ripple Counter, or 3-bit LUT
 - One Selectable Programmable Pattern Generator or 2-bit LUT
 - Four Selectable 8-bit CNT/DLYs or 3-bit LUTs
 - One Selectable 16-bit CNT/DLY or 4-bit LUT
- Asynchronous State Machine
 - Twelve States
 - Four Dynamic Memory Macrocells
 - f(1) Computation Macrocell with Dedicated ACMP
- Serial Communications
 - I²C Protocol Interface
- Programmable Delay with Edge Detector Output
- Deglitch Filter or Edge Detector
- Three Oscillators
 - 2.048 kHz Oscillator
 - 2.048 MHz Oscillator
 - 25 MHz Oscillator
- Crystal Oscillator
- Analog Temperature Sensor
- Power-On Reset
- Wide Range Power Supply
 - 2.5 V (±8 %) to 5 V (±10 %) V_{DD}
 - 2.5 V (±8 %) to 5 V (±10 %) V_{DD2} (V_{DD2} ≤ V_{DD}) for SLG46880
 - 1 V (±5 %) to 1.8 V (±10%) V_{DD2} for SLG46881
- Operating Temperature Range: -40 °C to 85 °C
- RoHS Compliant/Halogen-Free
- 32-pin STQFN: 4 mm x 4 mm x 0.55 mm, 0.4 mm pitch

Applications

- Personal Computers and Servers
- PC Peripherals
- Consumer Electronics
- Data Communications Equipment
- Handheld and Portable Electronics
- Smartphones and Fitness Bands
- Notebook and Tablet PCs

GreenPAK Programmable Mixed-Signal Matrix with Asynchronous State Machine and Dual Supply

Contents

General Description	1
Key Features	1
Applications	1
1 Block Diagram	9
2 Pinout	10
2.1 Pin Configuration - STQFN- 32L	10
3 Characteristics	12
3.1 Absolute Maximum Ratings	12
3.2 Electrostatic Discharge Ratings	12
3.3 Recommended Operating Conditions	12
3.4 Electrical Characteristics	13
3.5 Timing Characteristics	23
3.6 Oscillator Characteristics	27
3.7 Analog Comparator Characteristics	29
3.8 Analog Temperature Sensor Characteristics	31
4 User Programmability	34
5 IO Pins	35
5.1 IO Pins	35
5.2 Pull-Up/Down Resistors	35
5.3 100 ns Debounce Delay	35
5.4 Fast Pull-up/down during Power-up	35
5.5 Digital Input Latch	35
5.6 GPO Output Skew	36
5.7 Ultra-Low Power Digital Input (SLG46881 only)	36
5.8 GPI IO Structure (V _{DD})	37
5.9 GPI with Input Latch IO Structure (V _{DD})	39
5.10 GPI with I ² C Mode IO Structure (V _{DD})	41
5.11 GPIO with Matrix OE IO Structure (V _{DD} or V _{DD2})	43
5.12 GPIO with Matrix OE and Input Latch IO Structure (V _{DD} or V _{DD2})	45
5.13 GPI with Input Latch and Crystal Input IO Structure (V _{DD})	47
5.14 GPO Register OE IO Structure (V _{DD} or V _{DD2})	49
5.15 IO Typical Performance	50
6 Connection Matrix	53
6.1 Matrix Input Table	54
6.2 Matrix Output Table	55
6.3 Connection Matrix Virtual Inputs	58
6.4 Connection Matrix Virtual Outputs	58
7 Combination Function Macrocells	59
7.1 2-Bit LUT or D Flip-Flop Macrocells	59
7.2 2-bit LUT or Programmable Pattern Generator	61
7.3 3-Bit LUT or D Flip-Flop with Set/Reset Macrocells	63
7.4 3-Bit LUT or Pipe Delay/Ripple Counter Macrocell	69
7.5 3-Bit LUT or 8-Bit Counter/Delay Macrocells	73
7.6 CNT/DLY/FSM Timing Diagrams	78
7.7 4-Bit LUT or 16-Bit Counter/Delay Macrocell	86
7.8 Wake and Sleep Controller	88
8 Analog Comparators	93
8.1 ACMP0H Block Diagram	94
8.2 ACMP1H Block Diagram	95
8.3 ACMP2L Block Diagram	96
8.4 ACMP3L Block Diagram	97
8.5 ACMP Typical Performance	98
9 Programmable Delay/Edge Detector	102
9.1 Programmable Delay Timing Diagram - Edge Detector Output	102
10 Additional Logic Function	103

GreenPAK Programmable Mixed-Signal Matrix with Asynchronous
State Machine and Dual Supply

10.1 Deglitch Filter/Edge Detector	103
11 Voltage Reference	104
11.1 Voltage Reference Overview	104
11.2 Vref Selection Table	104
11.3 Truth Table for Vref0 Buffer and Output Switch Control	105
11.4 Truth Table for Vref1 Buffer and Output Switch Control	105
11.5 Vref Block Diagram	106
11.6 Vref Load Regulation	107
12 Clocking	109
12.1 General Description	109
12.2 Oscillator0 (2.048 kHz)	110
12.3 Oscillator1 (2.048 MHz)	111
12.4 Oscillator2 (25 MHz)	112
12.5 Clock Scheme	112
12.6 Crystal Oscillator	114
12.7 External Clocking	114
12.8 Oscillators Power-On Delay	115
12.9 Oscillators Accuracy	117
13 Power-On Reset	120
13.1 General Operation	120
13.2 POR Sequence	121
13.3 Macrocells Output States During POR Sequence	121
14 Asynchronous State Machine Subsystem	124
14.1 ASM Subsystem Overview	124
14.2 ASM Subsystem Input Signals	126
14.3 ASM Subsystem Output Signals	129
14.4 Basic ASM_Subsystem Timing	131
14.5 ASM Power Considerations	132
14.6 Asynchronous State Machines vs. Synchronous State Machines	133
14.7 ASM Special Case Timing Considerations	133
15 Asynchronous State Machine Macrocell	139
15.1 Asynchronous State Machine Overview	139
15.2 ASM Macrocell Input Signals	140
15.3 ASM Logical vs. Physical Design	143
16 Dynamic Memory Macrocell	145
16.1 Dynamic Memory Macrocell Overview	145
16.2 DM0_0 and DM0_1 Macrocell Architecture	146
16.3 DM1_0 and DM1_1 Macrocell Architecture	147
16.4 DMx_x Macrocell Input Signals	148
16.5 DMx_x Macrocell Output Signals	150
17 f(1) Computation Macrocell	152
17.1 f(1) Computation Macrocell Overview	152
17.2 f(1) Computation Macrocell Architecture	153
17.3 f(1) Computation Macrocell Input Signals	153
17.4 f(1) Computation Macrocell Output Signals	155
17.5 f(1) Command Registers	155
17.6 f(1) Typical Performance	162
18 Matrix Interface Macrocells	163
18.1 MI0, MI1, and MI2 Macrocell Architecture	163
18.2 Mlx Macrocell Input Signals	164
18.3 Mlx Macrocell Output Signals	164
19 I²C Serial Communications Macrocell	165
19.1 I ² C Serial Communications Macrocell Overview	165
19.2 I ² C Serial Communications Device Addressing	165
19.3 I ² C Serial General Timing	166
19.4 I ² C Serial Communications Commands	166
19.5 I ² C Serial Command Register Map	170

**GreenPAK Programmable Mixed-Signal Matrix with Asynchronous
State Machine and Dual Supply**

19.6 I ² C Additional Options	171
20 Analog Temperature Sensor	174
21 Register Definitions	177
21.1 Register Map	177
22 Package Top Marking System Definition	341
23 Package Information	342
23.1 STQFN Handling	343
23.2 Soldering Information	343
24 Ordering Information	343
24.1 Tape and Reel Specifications	343
24.2 Carrier Tape Drawing and Dimensions	343
25 Layout Guidelines	345
Glossary	346
Revision History	349

GreenPAK Programmable Mixed-Signal Matrix with Asynchronous State Machine and Dual Supply

Figures

Figure 1: Block Diagram.....	9
Figure 2: Steps to Create a Custom GreenPAK Device.....	34
Figure 3: Digital Input Latch Timing Diagram.....	35
Figure 4: Output Skew Timing Diagram.....	36
Figure 5: SLG46880 GPI IO Structure Diagram.....	37
Figure 6: SLG46881 GPI IO Structure Diagram.....	38
Figure 7: SLG46880 GPI with Input LATCH Structure Diagram.....	39
Figure 8: SLG46881 GPI with Input LATCH Structure Diagram.....	40
Figure 9: SLG46880 GPI with I2C Mode IO Structure Diagram.....	41
Figure 10: SLG46881 GPI with I2C Mode IO Structure Diagram.....	42
Figure 11: SLG46880 GPIO with Matrix OE IO Structure Diagram.....	43
Figure 12: SLG46881 GPIO with Matrix OE IO Structure Diagram.....	44
Figure 13: SLG46880 GPIO with Matrix OE and Input LATCH IO Structure Diagram.....	45
Figure 14: SLG46881 GPIO with Matrix OE and Input LATCH IO Structure Diagram.....	46
Figure 15: SLG46880 GPI with Input LATCH and Crystal Input IO Structure Diagram.....	47
Figure 16: SLG46881 GPI with Input LATCH and Crystal Input IO Structure Diagram.....	48
Figure 17: SLG46880/81 GPO Register OE IO Structure Diagram.....	49
Figure 18: Typical High Level Output Current vs. High Level Output Voltage at T = 25 °C.....	50
Figure 19: Typical Low Level Output Current vs. Low Level Output Voltage, 1x Drive at T = 25 °C, Full Range.....	50
Figure 20: Typical Low Level Output Current vs. Low Level Output Voltage, 1x Drive at T = 25 °C.....	51
Figure 21: Typical Low Level Output Current vs. Low Level Output Voltage, 2x Drive at T = 25 °C, Full Range.....	51
Figure 22: Typical Low Level Output Current vs. Low Level Output Voltage, 2x Drive at T = 25 °C.....	52
Figure 23: Connection Matrix.....	53
Figure 24: Connection Matrix Example.....	53
Figure 25: 2-bit LUT0 or DFF0.....	59
Figure 26: DFF Polarity Operations.....	61
Figure 27: 2-bit LUT1 or PGen.....	62
Figure 28: PGen Timing Diagram.....	62
Figure 29: 3-bit LUT0 or DFF1.....	64
Figure 30: 3-bit LUT1 or DFF2.....	65
Figure 31: 3-bit LUT2 or DFF3.....	65
Figure 32: 3-bit LUT3 or DFF4.....	66
Figure 33: DFF Polarity Operations with nReset.....	68
Figure 34: DFF Polarity Operations with nSet.....	69
Figure 35: 3-bit LUT8/Pipe Delay/Ripple Counter.....	71
Figure 36: Example: Ripple Counter Functionality.....	72
Figure 37: 3-bit LUT4 or CNT/DLY1.....	74
Figure 38: 3-bit LUT5 or CNT/DLY2.....	75
Figure 39: 3-bit LUT6 or CNT/DLY3.....	75
Figure 40: 3-bit LUT7 or CNT/DLY4.....	76
Figure 41: Delay Mode Timing Diagram.....	78
Figure 42: Counter Mode Timing Diagram without Two DFFs Synced Up.....	78
Figure 43: Counter Mode Timing Diagram with Two DFFs Synced Up.....	79
Figure 44: One-Shot Function Timing Diagram.....	79
Figure 45: Frequency Detection Mode Timing Diagram.....	80
Figure 46: Edge Detection Mode Timing Diagram.....	81
Figure 47: Delayed Edge Detection Mode Timing Diagram.....	82
Figure 48: Delay Mode Timing Diagram.....	83
Figure 49: CNT/FSM Timing Diagram (Reset Rising Edge Mode, Oscillator is Forced On, UP = 0) for Counter Data = 3.....	83
Figure 50: CNT/FSM Timing Diagram (Set Rising Edge Mode, Oscillator is Forced On, UP = 0) for Counter Data = 3.....	84
Figure 51: CNT/FSM Timing Diagram (Reset Rising Edge Mode, Oscillator is Forced On, UP = 1) for Counter Data = 3.....	84
Figure 52: CNT/FSM Timing Diagram (Set Rising Edge Mode, Oscillator is Forced On, UP = 1) for Counter Data = 3.....	85
Figure 53: Counter Value, Counter Data = 3.....	85
Figure 54: 4-bit LUT0 or CNT/DLY0.....	86
Figure 55: WS Controller.....	88

GreenPAK Programmable Mixed-Signal Matrix with Asynchronous State Machine and Dual Supply

Figure 56: Wake/Sleep Timing Diagram, Normal Wake Mode, Counter Reset is Used	89
Figure 57: Wake/Sleep Timing Diagram, Short Wake Mode, Counter Reset is Used	89
Figure 58: Wake/Sleep Timing Diagram, Normal Wake Mode, Counter Set is Used	90
Figure 59: Wake/Sleep Timing Diagram, Short Wake Mode, Counter Set is Used	90
Figure 60: ACMP0H Block Diagram	94
Figure 61: ACMP1H Block Diagram	95
Figure 62: ACMP2L Block Diagram	96
Figure 63: ACMP3L Block Diagram	97
Figure 64: Typical Propagation Delay vs. Vref for ACMPxH at T = 25 °C, Gain = 1, Buffer - Disabled, Hysteresis = 0	98
Figure 65: Typical Propagation Delay vs. Vref for ACMPxL at T = 25 °C, Gain = 1, Buffer - Disabled, Hysteresis = 0	98
Figure 66: ACMPxH Power-On Delay vs. V _{DD}	99
Figure 67: ACMPxL Power-On Delay vs. V _{DD}	99
Figure 68: ACMPxH Input Offset Voltage vs. Vref at T = -40 °C to 85 °C, Input Buffer Disabled	100
Figure 69: ACMPxL Input Offset Voltage vs. Vref at T = -40 °C to 85 °C, Input Buffer Disabled	100
Figure 70: ACMP Input Current Source vs. Input Voltage at T = -40 °C to 85 °C, V _{DD} = 3.3 V	101
Figure 71: Programmable Delay	102
Figure 72: Edge Detector Output	102
Figure 73: Deglitch Filter/Edge Detector	103
Figure 74: Voltage Reference Block Diagram	106
Figure 75: Typical Load Regulation, Vref = 320 mV, T = -40 °C to +85 °C, Buffer - Enable	107
Figure 76: Typical Load Regulation, Vref = 640 mV, T = -40 °C to +85 °C, Buffer - Enable	107
Figure 77: Typical Load Regulation, Vref = 1280 mV, T = -40 °C to +85 °C, Buffer - Enable	108
Figure 78: Typical Load Regulation, Vref = 2016 mV, T = -40 °C to +85 °C, Buffer - Enable	108
Figure 79: Oscillator0 Block Diagram	110
Figure 80: Oscillator1 Block Diagram	111
Figure 81: Oscillator2 Block Diagram	112
Figure 82: Clock Scheme	113
Figure 83: Crystal OSC Block Diagram	114
Figure 84: External Crystal Connection	114
Figure 85: Oscillator Startup Diagram	115
Figure 86: Oscillator0 Maximum Power-On Delay vs. V _{DD} at T = 25 °C, OSC0 = 2.048 kHz	116
Figure 87: Oscillator1 Maximum Power-On Delay vs. V _{DD} at T = 25 °C, OSC1 = 2.048 MHz	116
Figure 88: Oscillator2 Maximum Power-On Delay vs. V _{DD} at T = 25 °C, OSC2 = 25 MHz	117
Figure 89: Oscillator0 Frequency vs. Temperature, OSC0 = 2.048 kHz	117
Figure 90: Oscillator1 Frequency vs. Temperature, OSC1 = 2.048 MHz	118
Figure 91: Oscillator2 Frequency vs. Temperature, OSC2 = 25 MHz	118
Figure 92: Oscillators Total Error vs. Temperature	119
Figure 93: POR Sequence	121
Figure 94: Internal Macrocell States during POR Sequence	122
Figure 95: Power-Down	123
Figure 96: Asynchronous State Machine State Transitions	125
Figure 97: Connection Matrix to ASM Subsystem	126
Figure 98: ASM Subsystem Input Signals	128
Figure 99: Maximum 7 State Transitions out of a Given State	129
Figure 100: Maximum 11 State Transitions into Given State	129
Figure 101: ASM Subsystem Input Signals	130
Figure 102: State Transition	131
Figure 103: State Transition Timing	132
Figure 104: State Transition	132
Figure 105: State Transition Timing and Power Consumption	133
Figure 106: State Transition	134
Figure 107: State Transition Pulse Input Timing	134
Figure 108: State Transition - Competing Inputs	135
Figure 109: State Transition Timing - Competing Inputs Indeterminate	135
Figure 110: State Transition Timing - Competing Inputs Determinable	136
Figure 111: State Transition - Sequential	136
Figure 112: State Transition - Sequential Timing	137

GreenPAK Programmable Mixed-Signal Matrix with Asynchronous State Machine and Dual Supply

Figure 113: State Transition - Closed Cycling.....	137
Figure 114: State Transition - Closed Cycling Timing.....	138
Figure 115: Asynchronous State Machine State Transitions	139
Figure 116: 12 State ASM Macrocell.....	140
Figure 117: ASM Macrocell Input Signals	141
Figure 118: ASM Macrocell Output Signals	143
Figure 119: DM0_0/DM0_1	146
Figure 120: DM1_0/DM1_1	147
Figure 121: DM0_0/DM0_1 Inputs	148
Figure 122: DM1_0/DM1_1 Inputs	149
Figure 123: DM0_0/DM0_1 Outputs	150
Figure 124: DM1_0/DM1_1 Outputs	151
Figure 125: f(1) Computation Macrocell Architecture.....	153
Figure 126: f(1) Computation Macrocell Input Signals	154
Figure 127: f(1) Computation Macrocell Output Signals	155
Figure 128: f(1) Flowchart for Rising Edge Deglitch.....	160
Figure 129: f(1) Flowchart for Average Function for Captured Data	161
Figure 130: ACMP4F Power-On Delay vs. V_{DD}	162
Figure 131: ACMP4F Input Offset Voltage vs. V_{ref} at $T = -40\text{ }^{\circ}\text{C}$ to $85\text{ }^{\circ}\text{C}$, Input Buffer Disabled	162
Figure 132: Mix Macrocell Architecture.....	163
Figure 133: Basic Command Structure	166
Figure 134: I2C General Timing Characteristics	166
Figure 135: Byte Write Command, R/W = 0	167
Figure 136: Sequential Write Command	167
Figure 137: Current Address Read Command, R/W = 1	168
Figure 138: Random Read Command	168
Figure 139: Sequential Read Command	169
Figure 140: Reset Command Timing	169
Figure 141: Example of I2C Byte Write Bit Masking	173
Figure 142: Analog Temperature Sensor Structure Diagram.....	175
Figure 143: TS Output vs. Temperature, $V_{DD} = 2.3\text{ V}$ to 5.5 V	176

GreenPAK Programmable Mixed-Signal Matrix with Asynchronous State Machine and Dual Supply

Tables

Table 1: Functional Pin Description.....	10
Table 2: Pin Type Definitions	11
Table 3: Absolute Maximum Ratings.....	12
Table 4: Electrostatic Discharge Ratings	12
Table 5: Recommended Operating Conditions for SLG46880/81.....	12
Table 6: EC for SLG46880 at T = -40 °C to +85 °C, VDD = 2.3 V to 5.5 V Unless Otherwise Noted.....	13
Table 7: EC for SLG46881 at T = -40 °C to +85 °C, VDD = 2.3 V to 5.5 V Unless Otherwise Noted	15
Table 8: EC of the I ² C Pins at T = -40 °C to +85 °C, VDD = 2.3 V to 5.5 V Unless Otherwise Noted	19
Table 9: I ² C Pins Timing Characteristics at T = -40 °C to +85 °C, VDD = 2.3 V to 5.5 V Unless Otherwise Noted.....	20
Table 10: Asynchronous State Machine Specifications at T = 25 °C.....	20
Table 11: Typical Current Estimated for Each Macrocell at T = -40 °C to +85 °C	22
Table 12: Typical Delay Estimated for Each Macrocell at T = 25 °C.....	23
Table 13: Typical Delay Estimated for F(1) at T = 25 °C.....	24
Table 14: Programmable Delay Expected Delays and Widths (Typical) T = 25 °C	25
Table 15: Typical Filter Rejection Pulse Width at T = 25 °C	26
Table 16: Typical Counter/Delay Offset Measurements at T = 25 °C	26
Table 17: Oscillator0 2.048 kHz Frequency Limits.....	27
Table 18: Oscillator0 2.048 kHz Frequency Error (Error Calculated Relative to Nominal Value)	27
Table 19: Oscillator1 2.048 MHz Frequency Limits.....	27
Table 20: Oscillator1 2.048 MHz Frequency Error (Error Calculated Relative to Nominal Value)	27
Table 21: Oscillator2 25 MHz Frequency Limits.....	28
Table 22: Oscillator2 25 MHz Frequency Error (Error Calculated Relative to Nominal Value)	28
Table 23: Oscillators Power-On Delay at T = 25 °C, OSC Power Mode: "Auto Power-On".....	28
Table 24: ACMP Specifications at T = -40 °C to +85 °C, VDD = 2.3 V to 5.5 V Unless Otherwise Noted.....	29
Table 25: TS Output vs Temperature (Output range 1).....	31
Table 26: TS Output vs Temperature (Output Range 2)	32
Table 27: TS Output Error (Output Range 1)	32
Table 28: TS Output Error (Output Range 2)	33
Table 29: Matrix Input Table.....	54
Table 30: Matrix Output Table.....	55
Table 31: Connection Matrix Virtual Inputs	58
Table 32: 2-bit LUT0 Truth Table	60
Table 33: 2-bit LUT Standard Digital Functions	60
Table 34: 2-bit LUT1 Truth Table	63
Table 35: 2-bit LUT Standard Digital Functions	63
Table 36: 3-bit LUT0 Truth Table	67
Table 37: 3-bit LUT1 Truth Table	67
Table 38: 3-bit LUT2 Truth Table	67
Table 39: 3-bit LUT3 Truth Table	67
Table 40: 3-bit LUT Standard Digital Functions	67
Table 41: 3-bit LUT8 Truth Table	72
Table 42: 3-bit LUT4 Truth Table	77
Table 43: 3-bit LUT5 Truth Table	77
Table 44: 3-bit LUT6 Truth Table	77
Table 45: 3-bit LUT7 Truth Table	77
Table 46: 4-bit LUT0 Truth Table	87
Table 47: 4-bit LUT Standard Digital Functions	87
Table 48: WS Register Settings	92
Table 49: Vref Selection Table.....	104
Table 50: VrefO0 Truth Table.....	105
Table 51: VrefO1 Truth Table.....	105
Table 52: Oscillator Operation Mode Configuration Settings	109
Table 53: External Components Selection Table	114
Table 54: Read/Write Protection Options.....	170
Table 55: ASM Current State Bits Configuration.....	171
Table 56: Register Map.....	177

1 Block Diagram

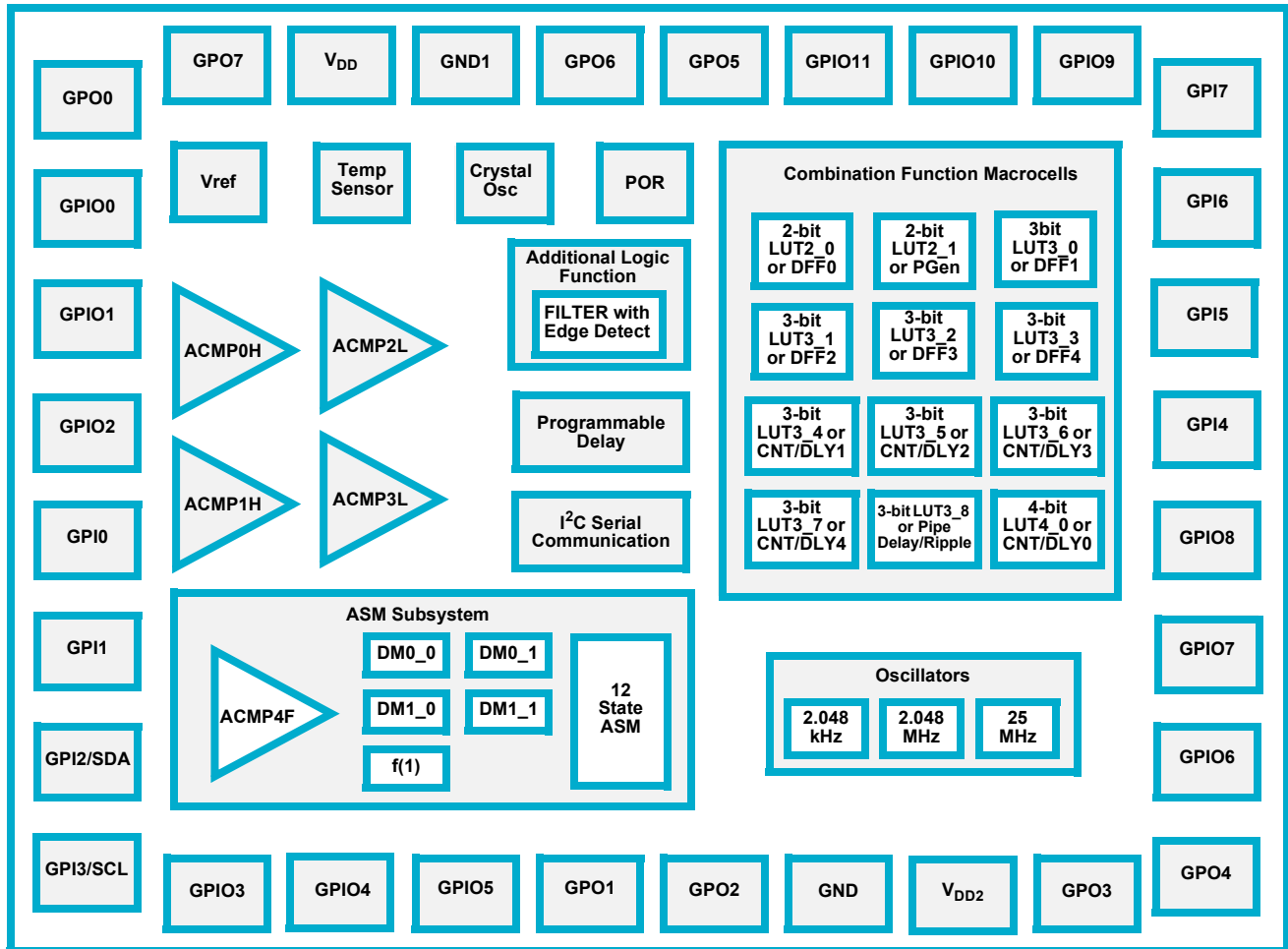

Figure 1: Block Diagram

GreenPAK Programmable Mixed-Signal Matrix with Asynchronous State Machine and Dual Supply

2 Pinout

2.1 PIN CONFIGURATION - STQFN- 32L

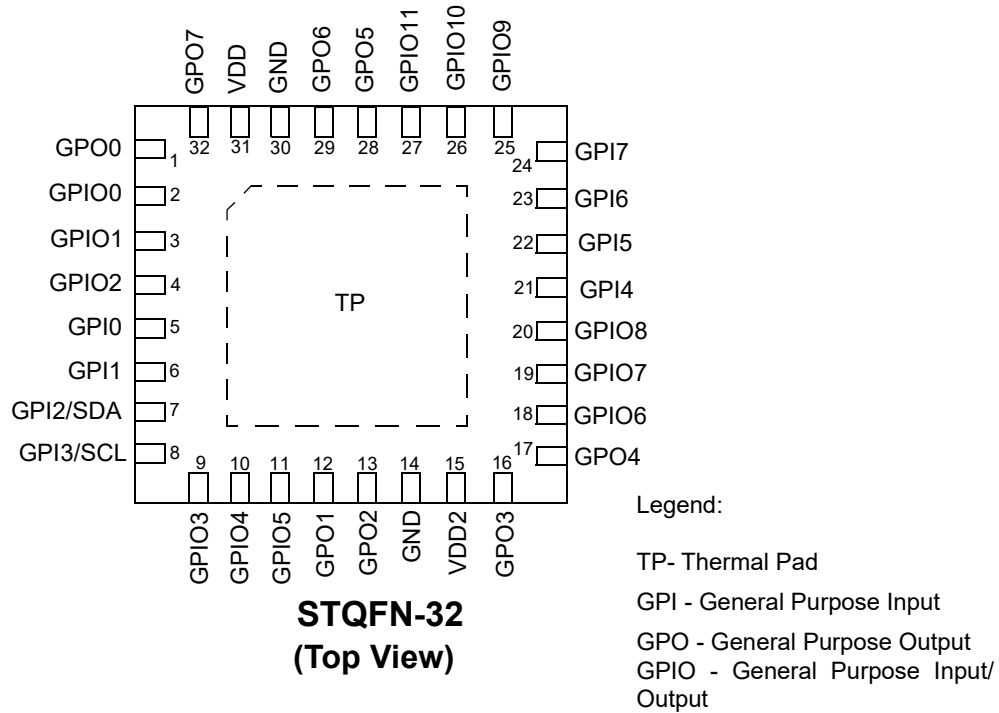

Table 1: Functional Pin Description

STQFN Pin #	Pin Name	Functions
1	GPO0	General Purpose Output or ACMP4F Input 1 or ASM1 output
2	GPIO0	General Purpose IO or ACMP4F Input 2
3	GPIO1	General Purpose IO or ACMP4F Input 3
4	GPIO2	General Purpose IO or VrefO1 or Din LATCH (en1)
5	GPI0	General Purpose Input or Din LATCH (en0)/EXT_CLK0
6	GPI1	General Purpose Input or Din LATCH (en0)/EXT_CLK1/Vref IN
7	GPI2/SDA	General Purpose Input/I ² C SDA
8	GPI3/SCL	General Purpose Input/I ² C SCL
9	GPIO3	General Purpose IO or Din LATCH (en1)
10	GPIO4	General Purpose IO or I ² C exp0 output
11	GPIO5	General Purpose IO or I ² C exp1 output
12	GPO1	General Purpose Output or ASM2 output
13	GPO2	General Purpose Output or ASM3 output
14	GND	Ground
15	V _{DD2}	Power Supply
16	GPO3	General Purpose Output or ASM4 output

GreenPAK Programmable Mixed-Signal Matrix with Asynchronous State Machine and Dual Supply

Table 1: Functional Pin Description(Continued)

STQFN Pin #	Pin Name	Functions
17	GPO4	General Purpose Output or ASM5 output
18	GPIO6	General Purpose IO or Din LATCH (en1) or I ² C exp2 output
19	GPIO7	General Purpose IO or Din LATCH (en1) or I ² C exp3 output
20	GPIO8	General Purpose IO or ACMP4F Input 7
21	GPI4	General Purpose Input (XTAL IN) or Din LATCH (en0)/EXT_CLK2
22	GPI5	General Purpose Input (XTAL OUT) or Din LATCH (en0)/EXT_CLK3
23	GPI6	General Purpose Input or ACMP4F Input 4
24	GPI7	General Purpose Input or ACMP4F Input 5
25	GPIO9	General Purpose IO or ACMP4F Input 6 or VrefO0
26	GPIO10	General Purpose IO or ACMP0H
27	GPIO11	General Purpose IO or ACMP1H
28	GPO5	General Purpose Output or ACMP2L or ASM6 output
29	GPO6	General Purpose Output or ACMP3L or ASM7 output
30	GND	Ground
31	V _{DD}	Power Supply
32	GPO7	General Purpose Output or ACMP4F Input 0 or ASM0 output
TP	TP	Thermal Pad. Must be connected to GND externally

Table 2: Pin Type Definitions

Pin Type	Description
V _{DD}	Power Supply
GPI	General Purpose Input
GPIO	General Purpose Input/Output
GPO	General Purpose Output
GND	Ground

GreenPAK Programmable Mixed-Signal Matrix with Asynchronous State Machine and Dual Supply

3 Characteristics

3.1 ABSOLUTE MAXIMUM RATINGS

Stresses beyond those listed under Absolute Maximum Ratings may cause permanent damage to the device. These are stress ratings only, so functional operation of the device at these or any other conditions beyond those indicated in the operational sections of the specification are not implied. Exposure to Absolute Maximum Rating conditions for extended periods may affect device reliability.

Table 3: Absolute Maximum Ratings

Parameter	Min	Max	Unit
Supply Voltage on V_{DD} relative to GND	-0.3	7	V
DC Input Voltage	GND - 0.5 V	$V_{DD} + 0.5$ V	V
Maximum Average or DC Current (Through V_{DD} or GND pin)	--	90	mA
Current at Input Pin	-1.0	1.0	mA
Input Leakage Current (Absolute Value)	--	1000	nA
Storage Temperature Range	-65	150	°C
Junction Temperature	--	150	°C
Moisture Sensitivity Level	1		

3.2 ELECTROSTATIC DISCHARGE RATINGS

Table 4: Electrostatic Discharge Ratings

Parameter	Min	Max	Unit
ESD Protection (Human Body Model)	2000	--	V
ESD Protection (Charged Device Model)	1300	--	V

3.3 RECOMMENDED OPERATING CONDITIONS

Table 5: Recommended Operating Conditions for SLG46880/81

Parameter	Condition	Min	Max	Unit
Supply Voltage (V_{DD})		2.3	5.5	V
Supply Voltage 2 (V_{DD2})	$V_{DD2} \leq V_{DD}$ for SLG46880	2.3	5.5	V
Supply Voltage 2 (V_{DD2})	$V_{DD2} \leq V_{DD}$ for SLG46881	0.95	1.98	V
Operating Temperature		-40	85	°C
Maximal Voltage Applied to any PIN in High Impedance State		--	$V_{DD} + 0.3$ (Note 1)	V
Capacitor Value at V_{DD}		0.1	--	μ F
Analog Input Common Mode Range	Allowable Input Voltage at Analog Pins	0	V_{DD}	V
Note 1 GPIs 0, 1, 2, 3, 4, 5, 6, 7, GPIOs 0, 1, 2, 3, 8, 9, 10, 11, GPOs 0, 5, 6, 7 are powered from V_{DD} and GPIOs 4, 5, 6, 7, GPOs 1, 2, 3, 4 are powered from V_{DD2} .				

GreenPAK Programmable Mixed-Signal Matrix with Asynchronous State Machine and Dual Supply

3.4 ELECTRICAL CHARACTERISTICS

Table 6: EC for SLG46880 at T = -40 °C to +85 °C, V_{DD} = 2.3 V to 5.5 V Unless Otherwise Noted

Parameter	Description	Condition	Min	Typ	Max	Unit
V _{IH}	HIGH-Level Input Voltage	Logic Input (Note 2)	0.7x V _{DD} (Note 1)	--	V _{DD} + 0.3 (Note 1)	V
		Logic Input with Schmitt Trigger	0.8x V _{DD} (Note 1)	--	V _{DD} + 0.3 (Note 1)	V
		Low-Level Logic Input (Note 2)	1.25	--	V _{DD} + 0.3 (Note 1)	V
V _{IL}	LOW-Level Input Voltage	Logic Input (Note 2)	GND- 0.3	--	0.3x V _{DD} (Note 1)	V
		Logic Input with Schmitt Trigger	GND- 0.3	--	0.2x V _{DD} (Note 1)	V
		Low-Level Logic Input (Note 2)	GND- 0.3	--	0.5	V
V _{HYS}	Schmitt Trigger Hysteresis Voltage	V _{DD} = 2.5 V ± 8 %	0.32	0.43	0.56	V
		V _{DD} = 3.3 V ± 10 %	0.36	0.46	0.57	V
		V _{DD} = 5 V ± 10 %	0.46	0.58	0.74	V
V _{OH}	HIGH-Level Output Voltage	Push-Pull, I _{OH} = 100 μA, 1x Drive, V _{DD} = 2.5 V ± 8 % (Note 1)	2.286	2.292	--	V
		Push-Pull, I _{OH} = 3 mA, 1x Drive, V _{DD} = V _{DD2} = 3.3 V ± 10 % (Note 1)	2.704	2.790	--	V
		Push-Pull, I _{OH} = 5 mA, 1x Drive, V _{DD} = V _{DD2} = 5 V ± 10 % (Note 1)	4.154	4.247	--	V
		Push-Pull, I _{OH} = 100 μA, 2x Drive, V _{DD} = 2.5 V ± 8 % (Note 1)	2.294	2.297	--	V
		Push-Pull, I _{OH} = 3 mA, 2x Drive, V _{DD} = V _{DD2} = 3.3 V ± 10 % (Note 1)	2.857	2.896	--	V
		Push-Pull, I _{OH} = 5 mA, 2x Drive, V _{DD} = V _{DD2} = 5 V ± 10 % (Note 1)	4.329	4.373	--	V
V _{OL}	LOW-Level Output Voltage	Push-Pull, I _{OL} = 100 μA, 1x Drive, V _{DD} = V _{DD2} = 2.5 V ± 8 % (Note 1)	--	0.006	0.025	V
		Push-Pull, I _{OL} = 3 mA, 1x Drive, V _{DD} = V _{DD2} = 3.3 V ± 10 % (Note 1)	--	0.158	0.217	V
		Push-Pull, I _{OL} = 5 mA, 1x Drive, V _{DD} = V _{DD2} = 5 V ± 10 % (Note 1)	--	0.212	0.297	V
		Push-Pull, I _{OL} = 100 μA, 2x Drive, V _{DD} = V _{DD2} = 2.5 V ± 8 % (Note 1)	--	0.003	0.013	V
		Push-Pull, I _{OL} = 3 mA, 2x Drive, V _{DD} = V _{DD2} = 3.3 V ± 10 % (Note 1)	--	0.079	0.107	V
		Push-Pull, I _{OL} = 5 mA, 2x Drive, V _{DD} = V _{DD2} = 5 V ± 10 % (Note 1)	--	0.099	0.136	V
		NMOS OD, I _{OL} = 100 μA, 1x Drive, V _{DD} = V _{DD2} = 2.5 V ± 8 % (Note 1)	--	0.003	0.011	V
		NMOS OD, I _{OL} = 3 mA, 1x Drive, V _{DD} = V _{DD2} = 3.3 V ± 10 % (Note 1)	--	0.063	0.087	V
		NMOS OD, I _{OL} = 5 mA, 1x Drive, V _{DD} = V _{DD2} = 5 V ± 10 % (Note 1)	--	0.079	0.114	V

GreenPAK Programmable Mixed-Signal Matrix with Asynchronous State Machine and Dual Supply

Table 6: EC for SLG46880 at T = -40 °C to +85 °C, V_{DD} = 2.3 V to 5.5 V Unless Otherwise Noted(Continued)

Parameter	Description	Condition	Min	Typ	Max	Unit
V _{OL}	LOW-Level Output Voltage	NMOS OD, I _{OL} = 100 μA, 2x Drive, V _{DD} = V _{DD2} = 2.5 V ± 8 % (Note 1)	--	0.001	0.002	V
		NMOS OD, I _{OL} = 3 mA, 2x Drive, V _{DD} = V _{DD2} = 3.3 V ± 10 % (Note 1)	--	0.033	0.046	V
		NMOS OD, I _{OL} = 5 mA, 2x Drive, V _{DD} = V _{DD2} = 5 V ± 10 % (Note 1)	--	0.041	0.061	V
I _{OH}	HIGH-Level Output Current	Push-Pull, V _{OH} = V _{DD} - 0.2, 1x Drive, V _{DD} = V _{DD2} = 2.5 V ± 8 % (Note 1)	1.55	2.14	--	mA
		Push-Pull, V _{OH} = 2.4 V, 1x Drive, V _{DD} = V _{DD2} = 3.3 V ± 10 % (Note 1)	5.54	7.48	--	mA
		Push-Pull, V _{OH} = 2.4 V, 1x Drive, V _{DD} = V _{DD2} = 5 V ± 10 % (Note 1)	19.89	24.83	--	mA
		Push-Pull, V _{OH} = V _{DD} - 0.2, 2x Drive, V _{DD} = V _{DD2} = 2.5 V ± 8 % (Note 1)	3.08	4.21	--	mA
		Push-Pull, V _{OH} = 2.4 V, 2x Drive, V _{DD} = V _{DD2} = 3.3 V ± 10 % (Note 1)	10.92	14.72	--	mA
		Push-Pull, V _{OH} = 2.4 V, 2x Drive, V _{DD} = V _{DD2} = 5 V ± 10 % (Note 1)	38.89	48.60	--	mA
I _{OL}	LOW-Level Output Current	Push-Pull, V _{OL} = 0.15 V, 1x Drive, V _{DD} = V _{DD2} = 2.5 V ± 8 % (Note 1)	1.66	2.19	--	mA
		Push-Pull, V _{OL} = 0.4 V, 1x Drive, V _{DD} = V _{DD2} = 3.3 V ± 10 % (Note 1)	5.26	7.00	--	mA
		Push-Pull, V _{OL} = 0.4 V, 1x Drive, V _{DD} = V _{DD2} = 5 V ± 10 % (Note 1)	7.15	9.76	--	mA
		Push-Pull, V _{OL} = 0.15 V, 2x Drive, V _{DD} = V _{DD2} = 2.5 V ± 8 % (Note 1)	3.32	4.29	--	mA
		Push-Pull, V _{OL} = 0.4 V, 2x Drive, V _{DD} = V _{DD2} = 3.3 V ± 10 % (Note 1)	10.40	13.69	--	mA
		Push-Pull, V _{OL} = 0.4 V, 2x Drive, V _{DD} = V _{DD2} = 5 V ± 10 % (Note 1)	14.06	18.98	--	mA
		NMOS OD, V _{OL} = 0.15 V, 1x Drive, V _{DD} = V _{DD2} = 2.5 V ± 8 % (Note 1)	4.15	5.38	--	mA
		NMOS OD, V _{OL} = 0.4 V, 1x Drive, V _{DD} = V _{DD2} = 3.3 V ± 10 % (Note 1)	12.90	17.14	--	mA
		NMOS OD, V _{OL} = 0.4 V, 1x Drive, V _{DD} = V _{DD2} = 5 V ± 10 % (Note 1)	16.98	23.70	--	mA
		NMOS OD, V _{OL} = 0.15 V, 2x Drive, V _{DD} = V _{DD2} = 2.5 V ± 8 % (Note 1)	7.89	10.40	--	mA
		NMOS OD, V _{OL} = 0.4 V, 2x Drive, V _{DD} = V _{DD2} = 3.3 V ± 10 % (Note 1)	24.47	33.02	--	mA
		NMOS OD, V _{OL} = 0.4 V, 2x Drive, V _{DD} = V _{DD2} = 5 V ± 10 % (Note 1)	31.20	45.10	--	mA
		T _{SU}	Startup Time	From V _{DD} rising past PON _{THR}	--	1.13
T _{WR}	NVM Page Write Time		--	--	20	ms
T _{ER}	NVM Page Erase Time		--	--	20	ms
PON _{THR}	Power-On Threshold	V _{DD} Level Required to Start Up the Chip	1.64	1.84	2.11	V
POFF _{THR}	Power-Off Threshold	V _{DD} Level Required to Switch Off the Chip	0.98	1.25	1.49	V

GreenPAK Programmable Mixed-Signal Matrix with Asynchronous State Machine and Dual Supply

Table 6: EC for SLG46880 at T = -40 °C to +85 °C, V_{DD} = 2.3 V to 5.5 V Unless Otherwise Noted(Continued)

Parameter	Description	Condition	Min	Typ	Max	Unit
R _{PULL}	Pull-up or Pull-down Resistance	1 M for Pull-up: V _{IN} = GND; for Pull-down: V _{IN} = V _{DD}	0.74	1.04	1.50	MΩ
		100 k for Pull-up: V _{IN} = GND; for Pull-down: V _{IN} = V _{DD}	87	104	132	kΩ
		10 k For Pull-up: V _{IN} = GND; for Pull-down: V _{IN} = V _{DD}	7	10	17	kΩ
C _{IN}	Input Capacitance		4		pF	

Note 1 GPIs 0, 1, 2, 3, 4, 5, 6, 7, GPIOs 0, 1, 2, 3, 8, 9, 10, 11, GPOs 0, 5, 6, 7 are powered from V_{DD} and GPIOs 4, 5, 6, 7, GPOs 1, 2, 3, 4 are powered from V_{DD2}.

Note 2 No hysteresis.

Table 7: EC for SLG46881 at T = -40 °C to +85 °C, V_{DD} = 2.3 V to 5.5 V Unless Otherwise Noted

Parameter	Description	Condition	Min	Typ	Max	Unit
V _{IH1}	HIGH-Level Input Voltage (GPIs 0, 1, 2, 3, 4, 5, 6, 7, GPIOs 0, 1, 2, 3, 8, 9, 10, 11)	Logic Input (Note 2)	0.7x V _{DD}	--	V _{DD} + 0.3	V
		Logic Input with Schmitt Trigger	0.8x V _{DD}	--	V _{DD} + 0.3	V
		Low-Level Logic Input (Note 2)	1.25	--	V _{DD} + 0.3	V
		Ultra-Low Power Digital Input (Note 2)	0.7x V _{DD2}	--	V _{DD2} + 0.3	
V _{IH2}	HIGH-Level Input Voltage (GPIOs 4, 5, 6, 7)	Ultra-Low Power Digital Input (Note 2)	0.7x V _{DD2}	--	V _{DD2} + 0.3	V
V _{IL1}	LOW-Level Input Voltage (GPIs 0, 1, 2, 3, 4, 5, 6, 7, GPIOs 0, 1, 2, 3, 8, 9, 10, 11)	Logic Input (Note 2)	GND- 0.3	--	0.3x V _{DD}	V
		Logic Input with Schmitt Trigger	GND- 0.3	--	0.2x V _{DD}	V
		Low-Level Logic Input (Note 2)	GND- 0.3	--	0.5	V
		Ultra-Low Power Digital Input (Note 2)	GND- 0.3	--	0.42x V _{DD2}	V
V _{IL2}	LOW-Level Input Voltage (GPIOs 4, 5, 6, 7)	Ultra-Low Power Digital Input (Note 2)	GND- 0.3	--	0.42x V _{DD2}	V
V _{HYS1}	Schmitt Trigger Hysteresis Voltage (GPIs 0, 1, 2, 3, 4, 5, 6, 7, GPIOs 0, 1, 2, 3, 8, 9, 10, 11)	V _{DD} = 2.5 V ± 8 %	0.27	0.43	0.59	V
		V _{DD} = 3.3 V ± 10 %	0.32	0.46	0.59	V
		V _{DD} = 5 V ± 10 %	0.42	0.58	0.76	V

GreenPAK Programmable Mixed-Signal Matrix with Asynchronous State Machine and Dual Supply

Table 7: EC for SLG46881 at T = -40 °C to +85 °C, V_{DD} = 2.3 V to 5.5 V Unless Otherwise Noted(Continued)

Parameter	Description	Condition	Min	Typ	Max	Unit
V _{OH1}	HIGH-Level Output Voltage (GPIOs 0, 1, 2, 3, 8, 9, 10, 11, GPOs 0, 5, 6, 7)	Push-Pull, I _{OH} = 100 μA, 1x Drive, V _{DD} = 2.5 V ± 8 %	2.29	2.49	--	V
		Push-Pull, I _{OH} = 3 mA, 1x Drive, V _{DD} = 3.3 V ± 10 %	2.69	3.11	--	V
		Push-Pull, I _{OH} = 5 mA, 1x Drive, V _{DD} = 5 V ± 10 %	4.14	4.77	--	V
		Push-Pull, I _{OH} = 100 μA, 2x Drive, V _{DD} = 2.5 V ± 8 %	2.29	2.50	--	V
		Push-Pull, I _{OH} = 3 mA, 2x Drive, V _{DD} = 3.3 V ± 10 %	2.85	3.21	--	V
		Push-Pull, I _{OH} = 5 mA, 2x Drive, V _{DD} = 5 V ± 10 %	4.32	4.88	--	V
V _{OH2}	HIGH-Level Output Voltage (GPIOs 4, 5, 6, 7, GPOs 1, 2, 3, 4)	Push-Pull, I _{OH} = 100 μA, 1x Drive, V _{DD2} = 1.0 V ± 5 %	0.923	0.957	--	V
		Push-Pull, I _{OH} = 100 μA, 1x Drive, V _{DD2} = 1.5 V ± 5 %	1.479	1.486	--	V
		Push-Pull, I _{OH} = 100 μA, 1x Drive, V _{DD2} = 1.8 V ± 10 %	1.780	1.886	--	V
		Push-Pull, I _{OH} = 100 μA, 2x Drive, V _{DD2} = 1.0 V ± 5 %	0.937	0.966	--	V
		Push-Pull, I _{OH} = 100 μA, 2x Drive, V _{DD2} = 1.5 V ± 5 %	1.489	1.493	--	V
		Push-Pull, I _{OH} = 100 μA, 2x Drive, V _{DD2} = 1.8 V ± 10 %	1.789	1.893	--	V
V _{OL1}	LOW-Level Output Voltage (GPIOs 0, 1, 2, 3, 8, 9, 10, 11, GPOs 0, 5, 6, 7)	Push-Pull, I _{OL} = 100 μA, 1x Drive, V _{DD} = 2.5 V ± 8 %	--	0.006	0.012	V
		Push-Pull, I _{OL} = 3 mA, 1x Drive, V _{DD} = 3.3 V ± 10 %	--	0.156	0.233	V
		Push-Pull, I _{OL} = 5 mA, 1x Drive, V _{DD} = 5 V ± 10 %	--	0.197	0.295	V
		Push-Pull, I _{OL} = 100 μA, 2x Drive, V _{DD} = 2.5 V ± 8 %	--	0.003	0.005	V
		Push-Pull, I _{OL} = 3 mA, 2x Drive, V _{DD} = 3.3 V ± 10 %	--	0.078	0.116	V
		Push-Pull, I _{OL} = 5 mA, 2x Drive, V _{DD} = 5 V ± 10 %	--	0.100	0.151	V
		NMOS OD, I _{OL} = 100 μA, 1x Drive, V _{DD} = 2.5 V ± 8 %	--	0.003	0.004	V
		NMOS OD, I _{OL} = 3 mA, 1x Drive, V _{DD} = 3.3 V ± 10 %	--	0.062	0.094	V
		NMOS OD, I _{OL} = 5 mA, 1x Drive, V _{DD} = 5 V ± 10 %	--	0.080	0.122	V
		NMOS OD, I _{OL} = 100 μA, 2x Drive, V _{DD} = 2.5 V ± 8 %	--	0.001	0.002	V
		NMOS OD, I _{OL} = 3 mA, 2x Drive, V _{DD} = 3.3 V ± 10 %	--	0.032	0.051	V
		NMOS OD, I _{OL} = 5 mA, 2x Drive, V _{DD} = 5 V ± 10 %	--	0.042	0.067	V

GreenPAK Programmable Mixed-Signal Matrix with Asynchronous State Machine and Dual Supply

Table 7: EC for SLG46881 at T = -40 °C to +85 °C, V_{DD} = 2.3 V to 5.5 V Unless Otherwise Noted(Continued)

Parameter	Description	Condition	Min	Typ	Max	Unit
V _{OL2}	LOW-Level Output Voltage (GPIOs 4, 5, 6, 7, GPOs 1, 2, 3, 4)	Push-Pull, I _{OL} = 100 μA, 1x Drive, V _{DD2} = 1.0 V ± 5 %	--	0.015	0.022	V
		Push-Pull, I _{OL} = 100 μA, 1x Drive, V _{DD2} = 1.5 V ± 5 %	--	0.012	0.018	V
		Push-Pull, I _{OL} = 100 μA, 1x Drive, V _{DD2} = 1.8 V ± 10 %	--	0.011	0.017	V
		Push-Pull, I _{OL} = 100 μA, 2x Drive, V _{DD2} = 1.0 V ± 5 %	--	0.007	0.011	V
		Push-Pull, I _{OL} = 100 μA, 2x Drive, V _{DD2} = 1.5 V ± 5 %	--	0.006	0.011	V
		Push-Pull, I _{OL} = 100 μA, 2x Drive, V _{DD2} = 1.8 V ± 10 %	--	0.006	0.008	V
		NMOS OD, I _{OL} = 100 μA, 1x Drive, V _{DD2} = 1.0 V ± 5 %	--	0.015	0.022	V
		NMOS OD, I _{OL} = 100 μA, 1x Drive, V _{DD2} = 1.5 V ± 5 %	--	0.012	0.018	V
		NMOS OD, I _{OL} = 100 μA, 1x Drive, V _{DD2} = 1.8 V ± 10 %	--	0.011	0.017	V
		NMOS OD, I _{OL} = 100 μA, 2x Drive, V _{DD2} = 1.0 V ± 5 %	--	0.007	0.011	V
		NMOS OD, I _{OL} = 100 μA, 2x Drive, V _{DD2} = 1.5 V ± 5 %	--	0.006	0.010	V
		NMOS OD, I _{OL} = 100 μA, 2x Drive, V _{DD2} = 1.8 V ± 10 %	--	0.006	0.008	V
I _{OH1}	HIGH-Level Output Current (GPIOs 0, 1, 2, 3, 8, 9, 10, 11, GPOs 0, 5, 6, 7)	Push-Pull, V _{OH} = V _{DD} - 0.2, 1x Drive, V _{DD} = 2.5 V ± 8 %	1.48	2.37	--	mA
		Push-Pull, V _{OH} = 2.4 V, 1x Drive, V _{DD} = 3.3 V ± 10 %	5.30	11.12	--	mA
		Push-Pull, V _{OH} = 2.4 V, 1x Drive, V _{DD} = 5 V ± 10 %	19.27	30.24	--	mA
		Push-Pull, V _{OH} = V _{DD} - 0.2, 2x Drive, V _{DD} = 2.5 V ± 8 %	2.91	4.67	--	mA
		Push-Pull, V _{OH} = 2.4 V, 2x Drive, V _{DD} = 3.3 V ± 10 %	10.47	21.89	--	mA
		Push-Pull, V _{OH} = 2.4 V, 2x Drive, V _{DD} = 5 V ± 10 %	37.75	59.04	--	mA
I _{OH2}	HIGH-Level Output Current (GPIOs 4, 5, 6, 7, GPOs 1, 2, 3, 4)	Push-Pull, V _{OH} = 2/3 V _{DD2} , 1x Drive, V _{DD2} = 1.0 V ± 5 %	1.16	1.55	--	mA
		Push-Pull, V _{OH} = 2/3 V _{DD2} , 1x Drive, V _{DD2} = 1.5 V ± 5 %	2.84	3.40	--	mA
		Push-Pull, V _{OH} = 2/3 V _{DD2} , 1x Drive, V _{DD2} = 1.8 V ± 10 %	3.55	4.52	--	mA
		Push-Pull, V _{OH} = 2/3 V _{DD2} , 2x Drive, V _{DD2} = 1.0 V ± 5 %	2.32	3.07	--	mA
		Push-Pull, V _{OH} = 2/3 V _{DD2} , 2x Drive, V _{DD2} = 1.5 V ± 5 %	5.57	6.74	--	mA
		Push-Pull, V _{OH} = 2/3 V _{DD2} , 2x Drive, V _{DD2} = 1.8 V ± 10 %	6.99	8.95	--	mA

GreenPAK Programmable Mixed-Signal Matrix with Asynchronous State Machine and Dual Supply

Table 7: EC for SLG46881 at T = -40 °C to +85 °C, V_{DD} = 2.3 V to 5.5 V Unless Otherwise Noted(Continued)

Parameter	Description	Condition	Min	Typ	Max	Unit
I _{OL1}	LOW-Level Output Current (GPIOs 0, 1, 2, 3, 8, 9, 10, 11, GPOs 0, 5, 6, 7)	Push-Pull, V _{OL} = 0.15 V, 1x Drive, V _{DD} = 2.5 V ± 8 %	1.58	2.26	--	mA
		Push-Pull, V _{OL} = 0.4 V, 1x Drive, V _{DD} = 3.3 V ± 10 %	4.94	7.24	--	mA
		Push-Pull, V _{OL} = 0.4 V, 1x Drive, V _{DD} = 5 V ± 10 %	6.65	9.82	--	mA
		Push-Pull, V _{OL} = 0.15 V, 2x Drive, V _{DD} = 2.5 V ± 8 %	3.07	4.43	--	mA
		Push-Pull, V _{OL} = 0.4 V, 2x Drive, V _{DD} = 3.3 V ± 10 %	9.63	14.18	--	mA
		Push-Pull, V _{OL} = 0.4 V, 2x Drive, V _{DD} = 5 V ± 10 %	12.86	19.13	--	mA
		NMOS OD, V _{OL} = 0.15 V, 1x Drive, V _{DD} = 2.5 V ± 8 %	3.83	5.55	--	mA
		NMOS OD, V _{OL} = 0.4 V, 1x Drive, V _{DD} = 3.3 V ± 10 %	11.92	17.72	--	mA
		NMOS OD, V _{OL} = 0.4 V, 1x Drive, V _{DD} = 5 V ± 10 %	15.81	23.84	--	mA
		NMOS OD, V _{OL} = 0.15 V, 2x Drive, V _{DD} = 2.5 V ± 8 %	7.18	10.72	--	mA
		NMOS OD, V _{OL} = 0.4 V, 2x Drive, V _{DD} = 3.3 V ± 10 %	22.17	34.11	--	mA
		NMOS OD, V _{OL} = 0.4 V, 2x Drive, V _{DD} = 5 V ± 10 %	28.68	45.34	--	mA
I _{OL2}	LOW-Level Output Current (GPIOs 4, 5, 6, 7, GPOs 1, 2, 3, 4)	Push-Pull, V _{OL} = 1/3 V _{DD2} , 1x Drive, V _{DD2} = 1.0 V ± 5 %	1.37	1.85	--	mA
		Push-Pull, V _{OL} = 1/3 V _{DD2} , 1x Drive, V _{DD2} = 1.5 V ± 5 %	3.26	4.00	--	mA
		Push-Pull, V _{OL} = 1/3 V _{DD2} , 1x Drive, V _{DD2} = 1.8 V ± 10 %	4.09	5.27	--	mA
		Push-Pull, V _{OL} = 1/3 V _{DD2} , 2x Drive, V _{DD2} = 1.0 V ± 5 %	2.70	3.67	--	mA
		Push-Pull, V _{OL} = 1/3 V _{DD2} , 2x Drive, V _{DD2} = 1.5 V ± 5 %	6.42	7.93	--	mA
		Push-Pull, V _{OL} = 1/3 V _{DD2} , 2x Drive, V _{DD2} = 1.8 V ± 10 %	8.08	10.44	--	mA
		NMOS OD, V _{OL} = 1/3 V _{DD2} , 1x Drive, V _{DD2} = 1.0 V ± 5 %	1.38	1.85	--	mA
		NMOS OD, V _{OL} = 1/3 V _{DD2} , 1x Drive, V _{DD2} = 1.5 V ± 5 %	3.24	4.00	--	mA
		NMOS OD, V _{OL} = 1/3 V _{DD2} , 1x Drive, V _{DD2} = 1.8 V ± 10 %	4.08	5.27	--	mA
		NMOS OD, V _{OL} = 1/3 V _{DD2} , 2x Drive, V _{DD2} = 1.0 V ± 5 %	2.70	3.67	--	mA
		NMOS OD, V _{OL} = 1/3 V _{DD2} , 2x Drive, V _{DD2} = 1.5 V ± 5 %	6.43	7.92	--	mA
		NMOS OD, V _{OL} = 1/3 V _{DD2} , 2x Drive, V _{DD2} = 1.8 V ± 10 %	8.09	10.44	--	mA
T _{SU}	Startup Time	From V _{DD} rising past PON _{THR}	--	1.13	1.72	ms
PON _{THR}	Power-On Threshold	V _{DD} Level Required to Start Up the Chip	1.64	1.84	2.11	V

GreenPAK Programmable Mixed-Signal Matrix with Asynchronous State Machine and Dual Supply

Table 7: EC for SLG46881 at T = -40 °C to +85 °C, V_{DD} = 2.3 V to 5.5 V Unless Otherwise Noted(Continued)

Parameter	Description	Condition	Min	Typ	Max	Unit
POFF _{THR}	Power-Off Threshold	V _{DD} Level Required to Switch Off the Chip	0.98	1.25	1.49	V
R _{PULL}	Pull-up or Pull-down Resistance	1 M for Pull-up: V _{IN} = GND; for Pull-down: V _{IN} = V _{DD}	0.85	1.048	1.32	MΩ
		100 k for Pull-up: V _{IN} = GND; for Pull-down: V _{IN} = V _{DD}	87	104.4	131	kΩ
		10 k for Pull-up: V _{IN} = GND; for Pull-down: V _{IN} = V _{DD}	7	10.36	14	kΩ
		1 M for Pull-up: V _{IN} = GND; for Pull-down: V _{IN} = V _{DD2}	0.85	1.05	1.35	MΩ
		100 k for Pull-up: V _{IN} = GND; for Pull-down: V _{IN} = V _{DD2}	88	112.5	150	kΩ
		10 k for Pull-up: V _{IN} = GND; for Pull-down: V _{IN} = V _{DD2}	9	14.14	22	kΩ
C _{IN}	Input Capacitance			4		pF

Note 1 GPIs 0, 1, 2, 3, 4, 5, 6, 7, GPIOs 0, 1, 2, 3, 8, 9, 10, 11, GPOs 0, 5, 6, 7 are powered from V_{DD} and GPIOs 4, 5, 6, 7, GPOs 1, 2, 3, 4 are powered from V_{DD2}.

Note 2 No hysteresis.

Table 8: EC of the I²C Pins at T = -40 °C to +85 °C, V_{DD} = 2.3 V to 5.5 V Unless Otherwise Noted

Parameter	Description	Condition	Fast-Mode		Fast-Mode Plus		Unit
			Min	Max	Min	Max	
V _{IL}	LOW-level Input Voltage		-0.5	0.3V _{DD}	-0.5	0.3 V _{DD}	V
V _{IH}	HIGH-level Input Voltage		0.7V _{DD}	5.5	0.7V _{DD}	5.5	V
V _{HYS}	Hysteresis of Schmitt Trigger Inputs		0.05V _{DD}	--	0.05V _{DD}	--	V
V _{OL1}	LOW-Level Output Voltage 1	(Open-Drain or open collector) at 3mA sink current V _{DD} > 2 V	0	0.4	0	0.4	V
V _{OL2}	LOW-Level Output Voltage 2	(Open-Drain or open collector) at 2 mA sink current V _{DD} ≤ 2 V	0	0.2V _{DD}	0	0.2V _{DD}	V
I _{OL}	LOW-Level Output Current (Note 1)	V _{OL} = 0.4 V, V _{DD} = 2.3 V	3	--	19.28	--	mA
		V _{OL} = 0.4 V, V _{DD} = 3.0 V	3	--	20	--	mA
		V _{OL} = 0.4 V, V _{DD} = 4.5 V	3	--	20	--	mA
		V _{OL} = 0.6 V	6	--	--	--	mA
t _{of}	Output Fall Time from V _{IHmin} to V _{ILmax} (Note 1)		14x (V _{DD} /5.5 V)	250	10x (V _{DD} /5.5 V)	120	ns
t _{SP}	Pulse Width of Spikes that must be suppressed by the Input Filter		0	50	0	50	ns

GreenPAK Programmable Mixed-Signal Matrix with Asynchronous State Machine and Dual Supply

Table 8: EC of the I²C Pins at T = -40 °C to +85 °C, V_{DD} = 2.3 V to 5.5 V Unless Otherwise Noted(Continued)

Parameter	Description	Condition	Fast-Mode		Fast-Mode Plus		Unit
			Min	Max	Min	Max	
I _i	Input Current each IO Pin	0.1V _{DD} < V _I < 0.9V _{DDmax}	-10	+10	-10	+10	μA
C _i	Capacitance for each IO Pin		--	10	--	10	pF

Note 1 Does not meet standard I²C specifications: t_{of} = 20x(V_{DD}/5.5 V) (min); For Fast-mode Plus I_{OL} = 20 mA (min) at V_{OL} = 0.4 V.
Note 2 For Fast-mode Plus SDA pin must be configured as NMOS 2x Open-Drain, see registers [893] in section 21.

Table 9: I²C Pins Timing Characteristics at T = -40 °C to +85 °C, V_{DD} = 2.3 V to 5.5 V Unless Otherwise Noted

Parameter	Description	Condition/Note	Fast-Mode		Fast-Mode Plus		Unit
			Min	Max	Min	Max	
F _{SCL}	Clock Frequency, SCL		--	400	--	1000	kHz
t _{LOW}	Clock Pulse Width Low		1300	--	500	--	ns
t _{HIGH}	Clock Pulse Width High		600	--	260	--	ns
t _i	Input Filter Spike Suppression (SCL, SDA)	V _{DD} = 2.5 V ± 8 %	--	95	--	168	ns
		V _{DD} = 3.3 V ± 10 %	--	95	--	157	
		V _{DD} = 5.0 V ± 10 %	--	111	--	156	
t _{AA}	Clock Low to Data Out Valid		--	900	--	450	ns
t _{BUF}	Bus Free Time between Stop and Start		1300	--	500	--	ns
t _{HD_STA}	Start Hold Time		600	--	260	--	ns
t _{SU_STA}	Start Set-up Time		600	--	260	--	ns
t _{HD_DAT}	Data Hold Time		0	--	0	--	ns
t _{SU_DAT}	Data Set-up Time		100	--	50	--	ns
t _R	Inputs Rise Time		--	300	--	120	ns
t _F	Inputs Fall Time		--	300	--	120	ns
t _{SU_STO}	Stop Set-up Time		600	--	260	--	ns
t _{DH}	Data Out Hold Time		50	--	50	--	ns

Note 1 Timing diagram can be found in the [Figure 134](#).

Table 10: Asynchronous State Machine Specifications at T = 25 °C

Parameter	Description	Condition	Min	Typ	Max	Unit
t _{st_out_delay}	Asynchronous State Machine Output Delay Time	V _{DD} = 2.5 V ± 8 %	133	--	277	ns
		V _{DD} = 3.3 V ± 10 %	96	--	190	
		V _{DD} = 5.0 V ± 10 %	70	--	123	
t _{st_out}	Asynchronous State Machine Output Transition Time	V _{DD} = 2.5 V ± 8 %	--	--	165	ns
		V _{DD} = 3.3 V ± 10 %	--	--	70	
		V _{DD} = 5.0 V ± 10 %	--	--	46	

GreenPAK Programmable Mixed-Signal Matrix with Asynchronous State Machine and Dual Supply

Table 10: Asynchronous State Machine Specifications at T = 25 °C(Continued)

Parameter	Description	Condition	Min	Typ	Max	Unit
t _{st_pulse}	Asynchronous State Machine Input Pulse Acceptance Time	V _{DD} = 2.5 V ± 8 %	28	--	--	ns
		V _{DD} = 3.3 V ± 10 %	19	--	--	
		V _{DD} = 5.0 V ± 10 %	12	--	--	
t _{st_comp}	Asynchronous State Machine Input Compete Time	V _{DD} = 2.5 V ± 8 %	--	--	10	ns
		V _{DD} = 3.3 V ± 10 %	--	--	7	
		V _{DD} = 5.0 V ± 10 %	--	--	5	
t _{st_sequential_delay}	Asynchronous State Machine Sequential Output Delay Time	V _{DD} = 2.5 V ± 8 %	229	--	485	ns
		V _{DD} = 3.3 V ± 10 %	162	--	330	
		V _{DD} = 5.0 V ± 10 %	119	--	208	
t _{st_dmlatch_delay}	Asynchronous State Machine Dynamic Memory Latch Delay	V _{DD} = 2.5 V ± 8 %	229	--	485	ns
		V _{DD} = 3.3 V ± 10 %	162	--	330	
		V _{DD} = 5.0 V ± 10 %	119	--	208	

GreenPAK Programmable Mixed-Signal Matrix with Asynchronous State Machine and Dual Supply

Table 11: Typical Current Estimated for Each Macrocell at T = -40 °C to +85 °C

Parameter	Description	Note	V _{DD} = 2.5 V	V _{DD} = 3.3 V	V _{DD} = 5.0 V	Unit
I	Current	Chip Quiescent (I ² C enable)	0.11	0.13	0.20	μA
		Chip Quiescent (I ² C disable)	0.10	0.12	0.20	μA
		Vref (SourceNone, SourceTempSensor)	0.39	0.43	0.53	μA
		Vref (ACMPxH or ACMPxL, 0.32 mV)	4.03	4.16	4.43	μA
		ACMP0H, 100 μA disabled, hysteresis disabled, gain 1 or 0.25, +IN - GPIO10, Vref = 32 mV	21.21	21.59	22.87	μA
		ACMP0H, 100 μA disabled, hysteresis disabled, gain 1, Buffered +IN - GPIO10, Vref = 32 mV	24.59	24.99	26.40	μA
		ACMP0,1H, 100 μA disabled, hysteresis disabled, gain 1, +IN - GPIO10, GPIO11, Vref = 32 mV	34.97	35.67	38.02	μA
		ACMP0,1H 100 μA disabled, ACMP2, 3L, hysteresis disabled, gain 1, +IN - GPIO10, GPIO11, GPO5, GPO6, Vref = 32 mV	36.32	36.96	39.37	μA
		ACMP0H, 100 μA disabled, hysteresis disabled, gain 1, +IN - V _{DD} , Vref = 32 mV	37.06	38.41	41.99	μA
		ACMP0H, 100 μA enabled, hysteresis disabled, gain 1, +IN - GPIO10, Vref = 32 mV	46.59	48.00	51.52	μA
		ACMP2L, hysteresis disabled, gain 1 or 0.25, +IN - GPO5, Vref = 32 mV	1.61	1.65	1.78	μA
		ACMP2,3L, hysteresis disabled, gain 1, +IN - GPO5, GPO6, Vref = 32 mV	1.86	1.91	2.04	μA
		OSC2 25 MHz, pre-divider = 1	111.45	150.85	244.34	μA
		OSC2 25 MHz, pre-divider = 4	42.67	54.93	84.46	μA
		OSC2 25 MHz, pre-divider = 8	30.94	38.56	57.16	μA
		OSC1 2.048 MHz, pre-divider = 1	16.20	17.52	20.42	μA
		OSC1 2.048 MHz, pre-divider = 4	13.83	14.37	15.60	μA
		OSC1 2.048 MHz, pre-divider = 8	13.42	13.83	14.78	μA
		OSC0 2.048 kHz, pre-divider = 1 or 4 or 8	0.39	0.43	0.53	μA
		Push-Pull 1x + 4 pF @ 25 kHz	0.4	5	16	μA
		Push-Pull 1x + 4 pF @ 2 MHz	22	47	106	μA
		Temperature Sensor, range 0.75 to 1.2, Source Matrix	4.64	4.74	4.85	μA
		Temperature Sensor, range 0.62 to 0.99, Source Matrix or Register	4.60	4.71	4.82	μA
		Temperature Sensor, range 0.62 to 0.99, Source Matrix or GPIO11	4.15	4.41	6.73	μA

GreenPAK Programmable Mixed-Signal Matrix with Asynchronous State Machine and Dual Supply

3.5 TIMING CHARACTERISTICS

Table 12: Typical Delay Estimated for Each Macrocell at T = 25 °C

Parameter	Description	Note	V _{DD} = 2.5 V		V _{DD} = 3.3 V		V _{DD} = 5 V		Unit
			Rising	Falling	Rising	Falling	Rising	Falling	
tpd	Delay	DFF Q	19	20	13	15	9	11	ns
tpd	Delay	DFF nQ	20	19	14	15	10	11	ns
tpd	Delay	DFF nRESET Q	--	23	--	16	--	11	ns
tpd	Delay	DFF nRESET nQ	23	--	15	--	10	--	ns
tpd	Delay	DFF nSET Q	23	--	15	--	10	--	ns
tpd	Delay	DFF nSET nQ	--	23	--	17	--	12	ns
tpd	Delay	DFF1 Second Q	20	21	14	15	9	11	ns
tpd	Delay	DFF1 Second nQ	21	20	14	15	9	10	ns
tpd	Delay	LATCH Q	18	20	13	14	9	10	ns
tpd	Delay	LATCH nQ	20	18	14	14	8	10	ns
tpd	Delay	LATCH nRESET Q	23	24	16	17	11	12	ns
tpd	Delay	LATCH nRESET nQ	24	24	16	17	11	13	ns
tpd	Delay	LATCH nSET Q	21	21	14	16	9	12	ns
tpd	Delay	LATCH nSET nQ	21	21	15	16	10	11	ns
tpd	Delay	LATCH1 second Q	20	21	14	15	9	11	ns
tpd	Delay	LATCH1 second nQ	21	20	15	15	10	11	ns
tpd	Delay	2-bit LUT	18	17	12	12	8	8	ns
tpd	Delay	3-bit LUT	22	24	16	18	11	13	ns
tpd	Delay	4-bit LUT	22	24	16	17	11	13	ns
tpd	Delay	DM 2-bit LUT IN0	16	18	11	13	7	9	ns
tpd	Delay	DM 3-bit LUT IN0 to 2-bit LUT IN0	18	21	13	15	9	10	ns
tpd	Delay	DM 3-bit LUT IN0 to CNT One Shot to 2-bit LUT IN1	52	55	38	39	26	26	ns
tpd	Delay	DM 3-bit LUT IN1 to 2-bit LUT IN0	17	19	12	14	8	9	ns
tpd	Delay	DM 3-bit LUT IN2 to 2-bit LUT IN0	18	19	12	14	8	10	ns
tpd	Delay	DM CNT Edge detect to 2-bit LUT IN1	41	42	29	30	20	20	ns
tpd	Delay	DM CNT Frequency detect to 2-bit LUT IN1	54	55	38	39	27	27	ns
tpd	Delay	DM CNT One Shot to 2-bit LUT IN1	52	54	37	38	25	26	ns
tpd	Delay	DM CNT Delay to 2-bit LUT IN1	44	44	31	32	21	22	ns
tpd	Delay	Low Voltage Digital input to PP 1x	42	224	29	152	20	96	ns
tpd	Delay	Digital input to with Schmitt Trigger to PP 1x	35	37	23	26	16	18	ns
tpd	Delay	Digital input to PP 1x	35	37	23	26	16	18	ns
tpd	Delay	Digital input to PP 2x	30	35	21	24	14	17	ns
tpd	Delay	PP 1x 3-State (Z to 0)	--	30	--	21	--	15	ns
tpd	Delay	PP 1x 3-State (Z to 1)	34	--	23	--	16	--	ns
tpd	Delay	PP 2x 3-State (Z to 0)	--	29	--	20	--	14	ns
tpd	Delay	PP 2x 3-State (Z to 1)	31	--	22	--	15	--	ns
tpd	Delay	Digital input to NMOS 1x	--	33	--	23	--	16	ns
tpd	Delay	Digital input to NMOS 2x	--	32	--	22	--	15	ns

GreenPAK Programmable Mixed-Signal Matrix with Asynchronous
 State Machine and Dual Supply

Table 12: Typical Delay Estimated for Each Macrocell at T = 25 °C(Continued)

Parameter	Description	Note	V _{DD} = 2.5 V		V _{DD} = 3.3 V		V _{DD} = 5 V		Unit
			Rising	Falling	Rising	Falling	Rising	Falling	
tpd	Delay	Ripple UP CLK CNT Q0	19	18	13	14	9	10	ns
tpd	Delay	Ripple UP CLK CNT Q1	24	26	17	19	12	15	ns
tpd	Delay	Ripple UP CLK CNT Q2	31	26	22	19	16	15	ns
tpd	Delay	Ripple DOWN CLK CNT Q0	18	18	13	14	9	10	ns
tpd	Delay	Ripple DOWN CLK CNT Q1	29	24	21	18	14	13	ns
tpd	Delay	Ripple DOWN CLK CNT Q2	29	31	21	23	15	17	ns
tpd	Delay	Ripple UP nSET CNT Q0	25	--	17	--	11	--	ns
tpd	Delay	Ripple UP nSET CNT Q1	24	--	17	--	11	--	ns
tpd	Delay	Ripple UP nSET CNT Q2	25	--	18	--	12	--	ns
tpd	Delay	Ripple DOWN nSET CNT Q0	25	--	17	--	11	--	ns
tpd	Delay	Ripple DOWN nSET CNT Q1	24	--	17	--	11	--	ns
tpd	Delay	Ripple DOWN nSET CNT Q2	25	--	17	--	12	--	ns
tpd	Delay	PGen CLK	18	18	12	13	8	10	ns
tpd	Delay	PGen nRESET (Z to 0)	--	20	--	15	--	11	ns
tpd	Delay	PGen nRESET (Z to 1)	22	--	15	--	10	--	ns
tpd	Delay	Pipe Delay Q	22	22	16	16	11	12	ns
tpd	Delay	Pipe Delay nQ	22	24	16	18	11	13	ns
tpd	Delay	Filter Q	165	144	112	101	71	68	ns
tpd	Delay	Filter nQ	145	164	101	113	67	72	ns
tpd	Delay	Edge detect	24	25	16	17	12	11	ns
tpd	Delay	Edge detect Delayed	242	243	177	179	129	130	ns
tw	Width	Edge detect	241	241	160	160	118	118	ns

Table 13: Typical Delay Estimated for F(1) at T = 25 °C

Parameter	Description	Note	V _{DD} = 2.5 V	V _{DD} = 3.3 V	V _{DD} = 5 V	Unit
tpd	Delay	Delay 0	159	111	71	ns
tpd	Delay	Delay 1	424	362	313	ns
tpd	Delay	Delay 10	786	722	672	ns
tpd	Delay	Delay 20	1185	1111	1070	ns
tpd	Delay	Delay 100	4395	4323	4264	ns
tpd	Delay	LOOP without Delay data	147	101	65	ns
tpd	Delay	LOOP with 0 Delay data	159	111	72	ns
tpd	Delay	LOOP with 1 Delay data	424	362	314	ns
tpd	Delay	LOOP with 10 Delay data	785	723	672	ns
tpd	Delay	LOOP with 20 Delay data	1186	1123	1071	ns
tpd	Delay	LOOP with 100 Delay data	4395	4324	4263	ns
tpd	Delay	INV	161	111	70	ns
tpd	Delay	AND	160	109	69	ns
tpd	Delay	OR	161	109	69	ns
tpd	Delay	XOR	160	109	69	ns

GreenPAK Programmable Mixed-Signal Matrix with Asynchronous State Machine and Dual Supply

Table 13: Typical Delay Estimated for F(1) at T = 25 °C(Continued)

Parameter	Description	Note	V _{DD} = 2.5 V	V _{DD} = 3.3 V	V _{DD} = 5 V	Unit
tpd	Delay	LOADx	322	219	137	ns
tpd	Delay	OUTx	163	110	69	ns
tpd	Delay	POP	160	109	69	ns
tpd	Delay	PUSH0	161	111	70	ns
tpd	Delay	RESET (Time for OUT0)	74	52	34	ns
tpd	Delay	RESET (Time to f1 init)	89	61	41	ns

Table 14: Programmable Delay Expected Delays and Widths (Typical) T = 25 °C

Parameter	Description	Note	V _{DD} = 2.5 V	V _{DD} = 3.3 V	V _{DD} = 5.0 V	Unit
time1	Pulse Width, 1 cell	mode: (any) edge detect, edge detect output	325	150	110	ns
time1	Pulse Width, 2 cell	mode: (any) edge detect, edge detect output	740	300	225	ns
time1	Pulse Width, 3 cell	mode: (any) edge detect, edge detect output	1020	450	340	ns
time1	Pulse Width, 4 cell	mode: (any) edge detect, edge detect output	1350	600	450	ns
time2	Delay, 1 cell	mode: (any) edge detect, edge detect output	44	18	14	ns
time2	Delay, 2 cell	mode: (any) edge detect, edge detect output	44	18	14	ns
time2	Delay, 3 cell	mode: (any) edge detect, edge detect output	44	18	14	ns
time2	Delay, 4 cell	mode: (any) edge detect, edge detect output	44	18	14	ns
time1	Pulse Width, 1 cell	mode: delayed (any) edge detect, delayed edge detect output	340	150	110	ns
time1	Pulse Width, 2 cell	mode: delayed (any) edge detect, delayed edge detect output	670	300	220	ns
time1	Pulse Width, 3 cell	mode: delayed (any) edge detect, delayed edge detect output	1000	450	335	ns
time1	Pulse Width, 4 cell	mode: delayed (any) edge detect, delayed edge detect output	1340	600	450	ns
time2	Delay, 1 cell	mode: delayed (any) edge detect, delayed edge detect output	570	220	140	ns
time2	Delay, 2 cell	mode: delayed (any) edge detect, delayed edge detect output	570	220	140	ns
time2	Delay, 3 cell	mode: delayed (any) edge detect, delayed edge detect output	570	220	140	ns
time2	Delay, 4 cell	mode: delayed (any) edge detect, delayed edge detect output	570	220	140	ns
time2	Delay, 1 cell	mode: both edge delay, edge detect output	382	375	126	ns
time2	Delay, 2 cell	mode: both edge delay, edge detect output	713	169	237	ns
time2	Delay, 3 cell	mode: both edge delay, edge detect output	1045	318	350	ns
time2	Delay, 4 cell	mode: both edge delay, edge detect output	1370	466	460	ns
time2	Delay, 1 cell	mode: both edge delay, delayed edge detect output	900	613	250	ns
time2	Delay, 2 cell	mode: both edge delay, delayed edge detect output	1250	520	360	ns
time2	Delay, 3 cell	mode: both edge delay, delayed edge detect output	1600	680	480	ns
time2	Delay, 4 cell	mode: both edge delay, delayed edge detect output	1900	815	600	ns

GreenPAK Programmable Mixed-Signal Matrix with Asynchronous State Machine and Dual Supply
Table 15: Typical Filter Rejection Pulse Width at T = 25 °C

Parameter	V _{DD} = 2.5 V	V _{DD} = 3.3 V	V _{DD} = 5.0 V	Unit
Filtered Pulse Width	< 123	< 84	< 52	ns

Table 16: Typical Counter/Delay Offset Measurements at T = 25 °C

Parameter	OSC Freq	OSC Power	V _{DD} = 2.5 V	V _{DD} = 3.3 V	V _{DD} = 5.0 V	Unit
Power-On time	25 MHz	auto	0.13	0.13	0.13	μs
Power-On time	2.048 MHz	auto	0.29	0.41	0.4	μs
Power-On time	2.048 kHz	auto	663	570	458	μs
frequency settling time	25 MHz	auto	4	4	8	μs
frequency settling time	2.048 MHz	auto	0.3	0.4	0.4	μs
frequency settling time	2.048 kHz	auto	660	570	480	μs
variable (CLK period)	25 MHz	forced	0-40	0-40	0-40	ns
variable (CLK period)	2.048 MHz	forced	0-0.5	0-0.5	0-0.5	μs
variable (CLK period)	2.048 kHz	forced	0-488	0-488	0-488	μs
tpd (non-delayed edge)	25 MHz/ 2.048 kHz	either	35	14	10	ns

GreenPAK Programmable Mixed-Signal Matrix with Asynchronous State Machine and Dual Supply

3.6 OSCILLATOR CHARACTERISTICS

Table 17: Oscillator0 2.048 kHz Frequency Limits

Power Supply Range (V _{DD}), V	Temperature Range			
	+25 °C		-40 °C to +85 °C	
	Minimum Value, kHz	Maximum Value, kHz	Minimum Value, kHz	Maximum Value, kHz
2.5 V ±8 %	2.026	2.071	1.907	2.088
3.3 V ±10 %	2.025	2.070	1.906	2.088
5 V ±10 %	2.025	2.071	1.905	2.087
2.5 V to 4.5 V	2.026	2.071	1.906	2.088
2.3 V to 5.5 V	2.025	2.071	1.905	2.088

Table 18: Oscillator0 2.048 kHz Frequency Error (Error Calculated Relative to Nominal Value)

Power Supply Range (V _{DD}), V	Temperature Range			
	+25 °C		-40 °C to +85 °C	
	Error (% at Minimum)	Error (% at Maximum)	Error (% at Minimum)	Error (% at Maximum)
2.5 V ±8 %	-1.07 %	1.12 %	-6.91 %	1.95 %
3.3 V ±10 %	-1.09 %	1.09 %	-6.94 %	1.94 %
5 V ±10 %	-1.12 %	1.11 %	-6.96 %	1.92 %
2.5 V to 4.5 V	-1.09 %	1.10 %	-6.96 %	1.95 %
2.3 V to 5.5 V	-1.12 %	1.12 %	-6.96 %	1.95 %

Table 19: Oscillator1 2.048 MHz Frequency Limits

Power Supply Range (V _{DD}), V	Temperature Range			
	+25 °C		-40 °C to +85 °C	
	Minimum Value, MHz	Maximum Value, MHz	Minimum Value, MHz	Maximum Value, MHz
2.5 V ±8 %	2.021	2.068	1.987	2.088
3.3 V ±10 %	2.024	2.069	1.990	2.089
5 V ±10 %	2.026	2.072	1.994	2.092
2.5 V to 4.5 V	2.022	2.071	1.988	2.090
2.3 V to 5.5 V	2.021	2.072	1.987	2.092

Table 20: Oscillator1 2.048 MHz Frequency Error (Error Calculated Relative to Nominal Value)

Power Supply Range (V _{DD}), V	Temperature Range			
	+25 °C		-40 °C to +85 °C	
	Error (% at Minimum)	Error (% at Maximum)	Error (% at Minimum)	Error (% at Maximum)
2.5 V ±8 %	-1.32 %	0.96 %	-2.98 %	1.93 %
3.3 V ±10 %	-1.14 %	1.01 %	-2.80 %	2.01 %

GreenPAK Programmable Mixed-Signal Matrix with Asynchronous State Machine and Dual Supply

Table 20: Oscillator1 2.048 MHz Frequency Error (Error Calculated Relative to Nominal Value)(Continued)

Power Supply Range (V _{DD}), V	Temperature Range			
	+25 °C		-40 °C to +85 °C	
	Error (% at Minimum)	Error (% at Maximum)	Error (% at Minimum)	Error (% at Maximum)
5 V ±10 %	-1.03 %	1.18 %	-2.61 %	2.13 %
2.5 V to 4.5 V	-1.27 %	1.09 %	-2.91 %	2.04 %
2.3 V to 5.5 V	-1.32 %	1.18 %	-2.98 %	2.13 %

Table 21: Oscillator2 25 MHz Frequency Limits

Power Supply Range (V _{DD}), V	Temperature Range			
	+25 °C		-40 °C to +85 °C	
	Minimum Value, MHz	Maximum Value, MHz	Minimum Value, MHz	Maximum Value, MHz
2.5 V ±8 %	24.588	25.238	23.622	25.669
3.3 V ±10 %	24.668	25.261	23.678	25.732
5 V ±10 %	24.736	25.353	23.723	25.803
2.5 V to 4.5 V	24.620	25.288	23.656	25.769
2.3 V to 5.5 V	24.588	25.353	23.622	25.803

Table 22: Oscillator2 25 MHz Frequency Error (Error Calculated Relative to Nominal Value)

Power Supply Range (V _{DD}), V	Temperature Range			
	+25 °C		-40 °C to +85 °C	
	Error (% at Minimum)	Error (% at Maximum)	Error (% at Minimum)	Error (% at Maximum)
2.5 V ±8 %	-1.65 %	0.96 %	-5.51 %	2.68 %
3.3 V ±10 %	-1.33 %	1.05 %	-5.29 %	2.93 %
5 V ±10 %	-1.06 %	1.42 %	-5.11 %	3.21 %
2.5 V to 4.5 V	-1.52 %	1.16 %	-5.38 %	3.08 %
2.3 V to 5.5 V	-1.65 %	1.42 %	-5.51 %	3.21 %

3.6.1 OSC Power-On Delay

Table 23: Oscillators Power-On Delay at T = 25 °C, OSC Power Mode: "Auto Power-On"

Power Supply Range (V _{DD}), V	Oscillator0 2.048 kHz		Oscillator1 2.048 MHz		Oscillator2 25 MHz		Oscillator2 25MHz Start with Delay	
	Typical Value, μs	Maximum Value, μs	Typical Value, μs	Maximum Value, μs	Typical Value, μs	Maximum Value, μs	Typical Value, μs	Maximum Value, μs
2.3	702.100	879.295	0.314	0.329	0.034	0.040	0.131	0.142
2.5	663.423	824.027	0.291	0.308	0.029	0.035	0.130	0.140
2.7	632.868	779.510	0.274	0.291	0.025	0.029	0.128	0.139
3	597.220	728.822	0.322	0.972	0.021	0.024	0.127	0.137

GreenPAK Programmable Mixed-Signal Matrix with Asynchronous State Machine and Dual Supply

Table 23: Oscillators Power-On Delay at T = 25 °C, OSC Power Mode: "Auto Power-On"

Power Supply Range (V _{DD}), V	Oscillator0 2.048 kHz		Oscillator1 2.048 MHz		Oscillator2 25 MHz		Oscillator2 25MHz Start with Delay	
	Typical Value, μs	Maximum Value, μs	Typical Value, μs	Maximum Value, μs	Typical Value, μs	Maximum Value, μs	Typical Value, μs	Maximum Value, μs
3.3	569.862	690.555	0.411	0.842	0.018	0.020	0.126	0.139
3.6	548.042	660.574	0.434	0.454	0.015	0.019	0.126	0.139
4	525.124	628.266	0.423	0.441	0.013	0.015	0.126	0.139
4.2	515.409	615.041	0.418	0.437	0.012	0.015	0.127	0.141
4.5	502.266	596.996	0.412	0.431	0.011	0.015	0.128	0.142
5	481.578	570.706	0.404	0.422	0.010	0.011	0.129	0.143
5.5	457.522	539.814	0.397	0.415	0.010	0.010	0.129	0.143

3.7 ANALOG COMPARATOR CHARACTERISTICS

Table 24: ACMP Specifications at T = -40 °C to +85 °C, V_{DD} = 2.3 V to 5.5 V Unless Otherwise Noted

Parameter	Description	Note	Condition	Min	Typ	Max	Unit
V _{ACMP}	ACMP0H, ACMP1H, ACMP2L, ACMP3L Input Voltage Range	Positive Input	V _{DD} = 2.5 V ± 5 %	0	--	V _{DD}	V
		Negative Input		0	--	2.016	V
		Positive Input	V _{DD} = 3.3 V ± 10 %	0	--	V _{DD}	V
		Negative Input		0	--	2.016	V
		Positive Input	V _{DD} = 5.0 V ± 10 %	0	--	V _{DD}	V
		Negative Input		0	--	2.016	V
V _{offset}	ACMP0H, ACMP1H Input Offset Voltage	V _{hys} = 0 mV, Gain = 1, V _{ref} = 32 mV to 2016 mV	T = 25 °C	0	--	5.68	mV
				0	--	6.33	mV
	ACMP2L, ACMP3L Input Offset Voltage		T = 25 °C	0	--	5.09	mV
				0	--	5.55	mV
t _{start}	ACMP0H, ACMP1H Start Time	ACMP Power-On delay, Minimal required wake time for the "Wake and Sleep function"	T = 25 °C	--	25.0	36.3	μs
				--	26.2	51.4	μs
	ACMP2L, ACMP3L Start Time		T = 25 °C	--	139.3	233.3	μs
				--	144.6	326.6	μs

GreenPAK Programmable Mixed-Signal Matrix with Asynchronous State Machine and Dual Supply

Table 24: ACMP Specifications at T = -40 °C to +85 °C, V_{DD} = 2.3 V to 5.5 V Unless Otherwise Noted (Continued)

Parameter	Description	Note	Condition	Min	Typ	Max	Unit
V _{HYS}	ACMP0H, ACMP1H Built-in Hysteresis	V _{HYS} = 32 mV	T = 25 °C	23.60	--	36.74	mV
		V _{HYS} = 64 mV	T = 25 °C	56.32	--	66.79	mV
		V _{HYS} = 192 mV	T = 25 °C	189.50	--	196.00	mV
		V _{HYS} = 32 mV		21.16	--	38.84	mV
		V _{HYS} = 64 mV		52.77	--	67.32	mV
		V _{HYS} = 192 mV		180.62	--	196.00	mV
	ACMP2L, ACMP3L Built-in Hysteresis	V _{HYS} = 32 mV	T = 25 °C	26.46	--	34.43	mV
		V _{HYS} = 64 mV	T = 25 °C	56.58	--	67.38	mV
		V _{HYS} = 192 mV	T = 25 °C	185.24	--	197.32	mV
		V _{HYS} = 32 mV		22.28	--	36.86	mV
		V _{HYS} = 64 mV		54.49	--	68.02	mV
		V _{HYS} = 192 mV		183.47	--	197.32	mV
R _{sin}	Series Input Resistance	Gain = 1x		--	100.0	--	MΩ
		Gain = 0.5x		--	1.0	--	MΩ
		Gain = 0.33x		--	0.8	--	MΩ
		Gain = 0.25x		--	1.0	--	MΩ
PROP	Propagation Delay, Response Time for ACMP0H, ACMP1H	Gain = 1, V _{ref} = 32 mV to 2016 mV, Overdrive = 5 mV	Low to High	--	2.53	4.73	μs
			High to Low	--	1.88	9.48	μs
		Gain = 1, V _{ref} = 32 mV to 2016 mV, Overdrive = 10 mV	Low to High	--	1.75	3.20	μs
			High to Low	--	1.36	2.30	μs
		Gain = 1, V _{ref} = 32 mV to 2016 mV, Overdrive = 100 mV	Low to High	--	0.81	7.42	μs
			High to Low	--	0.55	0.84	μs
	Propagation Delay, Response Time for ACMP2L, ACMP3L	Gain = 1, V _{ref} = 32 mV to 2016 mV, Overdrive = 5 mV	Low to High	--	74.91	139.75	μs
			High to Low	--	72.28	213.26	μs
		Gain = 1, V _{ref} = 32 mV to 2016 mV, Overdrive = 10 mV	Low to High	--	49.54	70.23	μs
			High to Low	--	46.92	68.44	μs
		Gain = 1, V _{ref} = 32 mV to 2016 mV, Overdrive = 100 mV	Low to High	--	18.41	29.06	μs
			High to Low	--	16.54	26.87	μs
G	Gain error (including threshold and internal V _{ref} error)	G = 1,		--	1	--	
		G = 0.5,		0.497	--	0.504	
		G = 0.33,		0.330	--	0.337	
		G = 0.25,		0.247	--	0.253	

GreenPAK Programmable Mixed-Signal Matrix with Asynchronous State Machine and Dual Supply

Table 24: ACMP Specifications at T = -40 °C to +85 °C, V_{DD} = 2.3 V to 5.5 V Unless Otherwise Noted (Continued)

Parameter	Description	Note	Condition	Min	Typ	Max	Unit
Vref	Vref0 Output Capacitance Loading		Resistance Load = 1 MΩ	--	--	5	pF
			Resistance Load = 560 kΩ	--	--	10	pF
			Resistance Load = 100 kΩ	--	--	40	pF
			Resistance Load = 10 kΩ	--	--	80	pF
			Resistance Load = 2 kΩ	--	--	120	pF
			Resistance Load = 1 kΩ, Vref = 32 mV to 1024 mV	--	--	150	pF
Vref	Vref1 Output Capacitance Loading		Resistance Load = 1 MΩ	--	--	15	pF
			Resistance Load = 560 kΩ	--	--	27	pF
			Resistance Load = 100 kΩ	--	--	64	pF
			Resistance Load = 10 kΩ	--	--	120	pF
			Resistance Load = 2 kΩ	--	--	180	pF
			Resistance Load = 1 kΩ, Vref = 32 mV to 1024 mV	--	--	210	pF
I _s	Input Current Source		V _{in} = V _{DD} - 0.7 V	83.3	95.4	109.8	μA

3.8 ANALOG TEMPERATURE SENSOR CHARACTERISTICS

Temperature Sensor typical nonlinearity ±0.27 % for output range 1 and ±0.29 % for output range 2 at V_{DD} = 3.3 V.

Table 25: TS Output vs Temperature (Output range 1)

T, °C	V _{DD} = 2.5 V		V _{DD} = 3.3 V		V _{DD} = 5.0 V	
	Typical, mV	Accuracy, %	Typical, mV	Accuracy, %	Typical, mV	Accuracy, %
-40	997	±0.45	997	±0.45	997	±0.45
-30	973	±0.22	973	±0.22	973	±0.22
-20	950	±0.28	950	±0.28	950	±0.29
-10	927	±0.21	927	±0.20	927	±0.21
0	905	±0.30	905	±0.30	905	±0.30
10	882	±0.28	882	±0.28	882	±0.28
20	859	±0.27	859	±0.27	859	±0.28
30	836	±0.21	836	±0.21	836	±0.21
40	813	±0.29	813	±0.28	813	±0.28

GreenPAK Programmable Mixed-Signal Matrix with Asynchronous State Machine and Dual Supply

Table 25: TS Output vs Temperature (Output range 1)(Continued)

T, °C	V _{DD} = 2.5 V		V _{DD} = 3.3 V		V _{DD} = 5.0 V	
	Typical, mV	Accuracy, %	Typical, mV	Accuracy, %	Typical, mV	Accuracy, %
50	790	±0.32	790	±0.32	790	±0.32
60	766	±0.52	766	±0.52	766	±0.51
70	743	±0.62	743	±0.62	743	±0.61
80	719	±0.82	719	±0.82	719	±0.82
85	707	±0.82	707	±0.82	707	±0.82

Table 26: TS Output vs Temperature (Output Range 2)

T, °C	V _{DD} = 2.5 V		V _{DD} = 3.3 V		V _{DD} = 5.0 V	
	Typical, mV	Accuracy, %	Typical, mV	Accuracy, %	Typical, mV	Accuracy, %
-40	1186	±0.54	1187	±0.50	1187	±0.60
-30	1158	±0.29	1158	±0.29	1158	±0.29
-20	1131	±0.26	1131	±0.27	1131	±0.27
-10	1104	±0.26	1104	±0.26	1104	±0.25
0	1076	±0.37	1076	±0.37	1076	±0.37
10	1049	±0.36	1049	±0.37	1049	±0.37
20	1021	±0.36	1021	±0.35	1021	±0.37
30	994	±0.24	994	±0.25	994	±0.25
40	966	±0.34	966	±0.33	966	±0.33
50	938	±0.46	938	±0.47	938	±0.47
60	910	±0.63	910	±0.64	910	±0.64
70	881	±0.75	881	±0.75	881	±0.75
80	852	±0.93	852	±0.93	852	±0.92
85	838	±1.02	838	±1.03	838	±1.02

Table 27: TS Output Error (Output Range 1)

V _{DD} , V	Error at T							
	-40 °C, %	-20 °C, %	0 °C, %	20 °C, %	40 °C, %	60 °C, %	80 °C, %	85 °C, %
2.30	±0.44	±0.28	±0.30	±0.28	±0.29	±0.52	±0.82	±0.82
2.50	±0.45	±0.28	±0.30	±0.27	±0.29	±0.52	±0.82	±0.82
2.70	±0.46	±0.28	±0.30	±0.27	±0.28	±0.52	±0.84	±0.84
3.00	±0.45	±0.29	±0.30	±0.27	±0.28	±0.53	±0.82	±0.82
3.30	±0.45	±0.28	±0.30	±0.27	±0.28	±0.52	±0.82	±0.82
3.60	±0.45	±0.28	±0.31	±0.27	±0.28	±0.53	±0.82	±0.82
4.00	±0.45	±0.28	±0.30	±0.27	±0.28	±0.52	±0.82	±0.82
4.20	±0.44	±0.28	±0.30	±0.28	±0.28	±0.52	±0.82	±0.82
4.50	±0.45	±0.28	±0.30	±0.27	±0.28	±0.51	±0.82	±0.82
5.00	±0.45	±0.29	±0.30	±0.28	±0.28	±0.51	±0.82	±0.82
5.50	±0.44	±0.28	±0.30	±0.28	±0.28	±0.51	±0.82	±0.83

GreenPAK Programmable Mixed-Signal Matrix with Asynchronous State Machine and Dual Supply
Table 28: TS Output Error (Output Range 2)

V _{DD} , V	Error at T							
	-40 °C, %	-20 °C, %	0 °C, %	20 °C, %	40 °C, %	60 °C, %	80 °C, %	85 °C, %
2.30	±0.62	±0.27	±0.37	±0.35	±0.34	±0.63	±0.94	±1.02
2.50	±0.54	±0.26	±0.37	±0.36	±0.34	±0.63	±0.93	±1.02
2.70	±0.72	±0.26	±0.37	±0.36	±0.34	±0.62	±0.94	±1.03
3.00	±0.41	±0.26	±0.37	±0.36	±0.33	±0.64	±0.93	±1.02
3.30	±0.50	±0.27	±0.37	±0.35	±0.33	±0.64	±0.93	±1.03
3.60	±0.66	±0.26	±0.37	±0.36	±0.34	±0.64	±0.93	±1.02
4.00	±0.82	±0.26	±0.37	±0.36	±0.34	±0.64	±0.93	±1.03
4.20	±0.43	±0.27	±0.37	±0.36	±0.34	±0.64	±0.92	±1.02
4.50	±0.72	±0.27	±0.37	±0.37	±0.34	±0.64	±0.92	±1.02
5.00	±0.60	±0.27	±0.37	±0.37	±0.33	±0.64	±0.92	±1.02
5.50	±0.58	±0.27	±0.37	±0.36	±0.34	±0.64	±0.93	±1.03

GreenPAK Programmable Mixed-Signal Matrix with Asynchronous State Machine and Dual Supply

4 User Programmability

The SLG46880/81 is a user programmable device with a one time programmable (OTP) memory array that is used to configure the 12 state ASM, logic, and Mixed-Signal circuits. Three of the IO Pins provide a connection for the bit patterns into the OTP on board memory. A programming development kit allows the user the ability to create initial devices. Once the design is finalized, the programming code (.gpx file) is forwarded to Dialog Semiconductor to integrate into a production process.

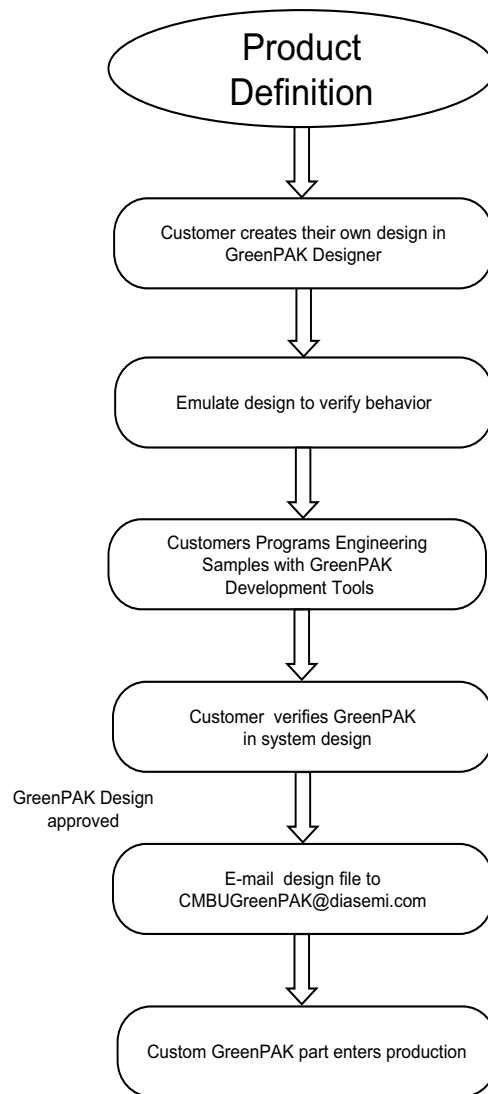

Figure 2: Steps to Create a Custom GreenPAK Device

GreenPAK Programmable Mixed-Signal Matrix with Asynchronous State Machine and Dual Supply

5 IO Pins

5.1 IO PINS

The SLG46880/81 has a total of 12 GPIO, 8 GPI, and 8 GPO pins, which can function either as a user defined Input or Output, or as a special function (such as outputting the voltage reference), as well as a signal for programming of the on-chip Non Volatile Memory (NVM). Refer to Section 2 for pin definitions.

GPIs 0, 1, 2, 3, 4, 5, 6, 7, GPIOs 0, 1, 2, 3, 8, 9, 10, 11, GPOs 0, 5, 6, 7 are powered from V_{DD} and GPIOs 4, 5, 6, 7, GPOs 1, 2, 3, 4 are powered from V_{DD2} . All internal macrocells are powered from V_{DD} . Voltage on V_{DD2} Pin must be less or equal voltage on V_{DD} Pin.

In case V_{DD2} floating and any Pin powered from V_{DD2} is configured as input, ESD pin protection diodes must be considered when applying an input signal to the pin. This will cause a significant current leakage.

In case V_{DD2} floating and any Pin powered from V_{DD2} is configured as Output, the pin will behave as NMOS Open-Drain.

It is not recommended to connect V_{DD2} to the GND.

5.2 PULL-UP/DOWN RESISTORS

All IO Pins have the option of user-selectable resistors that can be connected to the pin structure. The selectable values on these resistors are 10 k Ω , 100 k Ω , and 1 M Ω . The internal resistors can be configured as either Pull-up or Pull-downs.

5.3 100 NS DEBOUNCE DELAY

100 ns debounce can be enabled for GPIO, GPI1, GPI5, and GPI6 by setting registers [536], [537], [538], and [539], respectively.

5.4 FAST PULL-UP/DOWN DURING POWER-UP

During power-up, IO Pull-up/down resistance will switch to 2.6 k Ω initially and then it will switch to normal setting value. This function is enabled by register [670].

5.5 DIGITAL INPUT LATCH

Digital Input Latch can be enabled for GPIO, GPI1, GPI4, GPI5, GPIO2, GPIO3, GPIO6, GPIO7. For timing diagram refer to Figure 3.

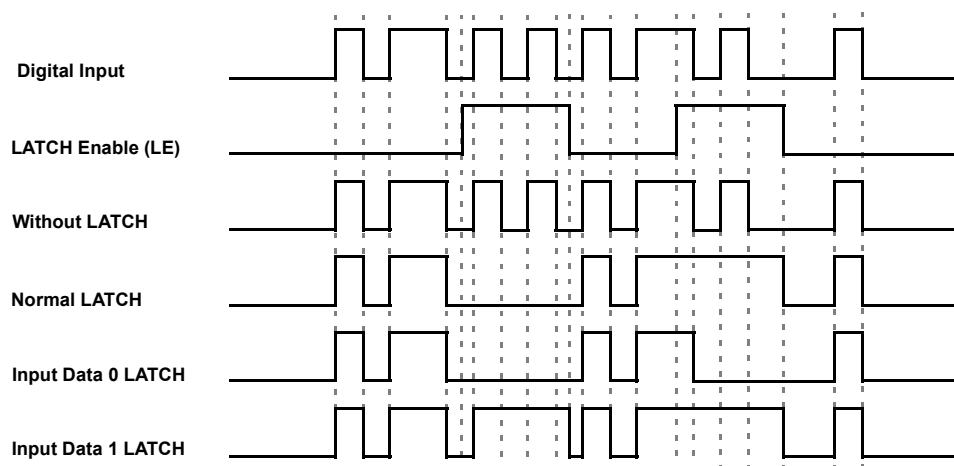

Figure 3: Digital Input Latch Timing Diagram

GreenPAK Programmable Mixed-Signal Matrix with Asynchronous State Machine and Dual Supply

5.6 GPO OUTPUT SKEW

Output Skew function can be enabled for GPOs 0 to 7. Once enabled for any GPO (register [671]), Output Skew becomes valid for all GPOs. All eight GPOs are grouped in pairs: GPO0 and GPO7, GPO1 and GPO2, GPO3 and GPO4, GPO5 and GPO6. Output Skew allows to delay each pair before setting HIGH or LOW consequently. See [Figure 4](#).

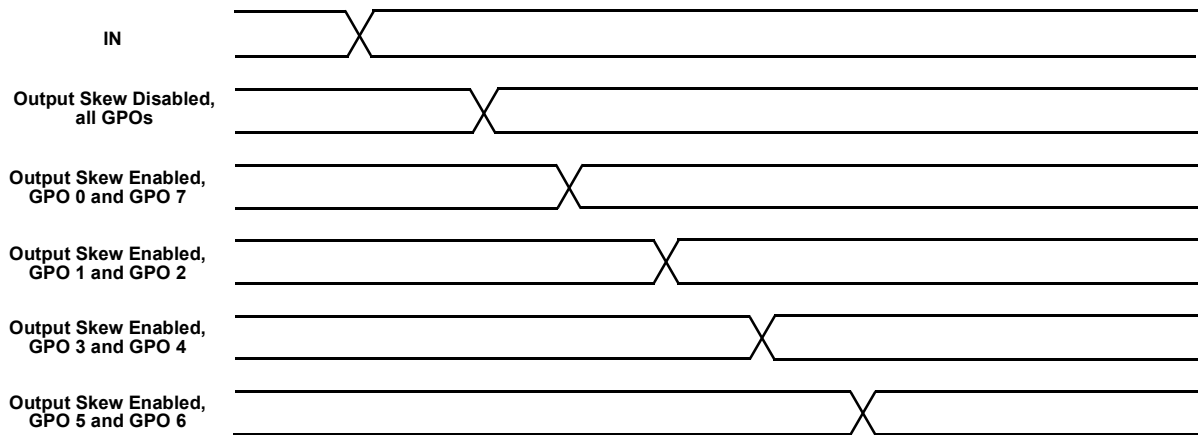

Figure 4: Output Skew Timing Diagram

5.7 ULTRA-LOW POWER DIGITAL INPUT (SLG46881 ONLY)

SLG46881 has an Ultra-Low Power Digital Input option that can be applied to GPIOs 0 to 11 and GPIs 1 to 7. Note that when Ultra-Low Power Digital Input is enabled, Pull-up resistors for GPIOs 0 to 3, 8 to 11, GPIs 1 to 7 switch from V_{DD} to V_{DD2} .

GreenPAK Programmable Mixed-Signal Matrix with Asynchronous State Machine and Dual Supply

5.8 GPI IO STRUCTURE (V_{DD})

5.8.1 SLG46880 GPI IO Structure (for GPIs 6, 7)

Input Mode [1:0]
 00: Digital In without Schmitt Trigger, wosmt_en = 1
 01: Digital In with Schmitt Trigger, smt_en = 1
 10: Low Voltage Digital In mode, lv_en = 1
 11: Analog IO mode

Note 1: 100 ns debounce is available for GPI6 only
 Note 2: Can be varied over PVT, for reference only

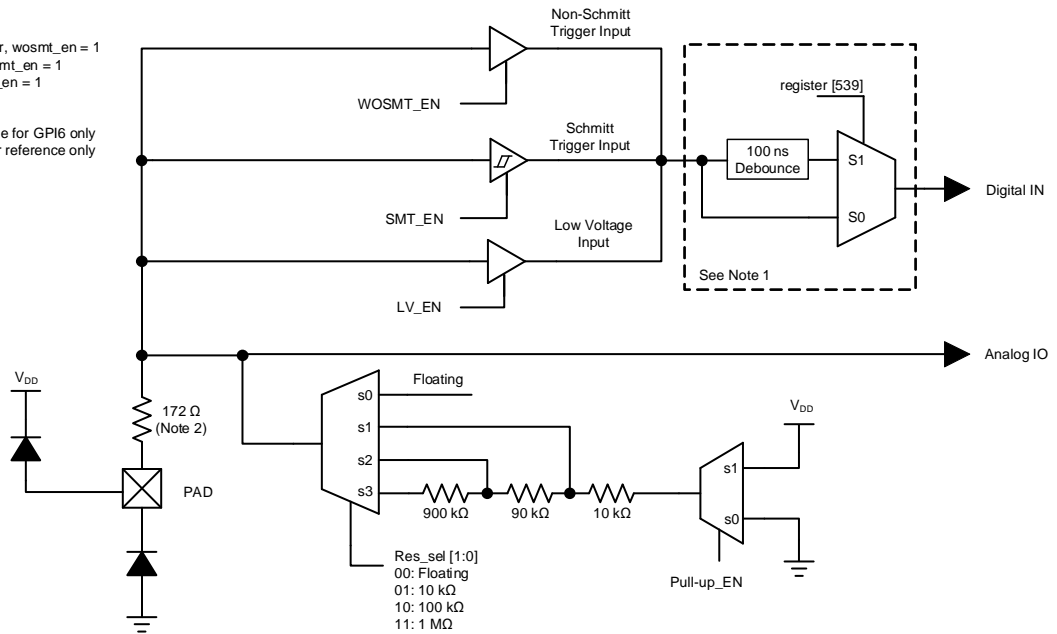

Figure 5: SLG46880 GPI IO Structure Diagram

GreenPAK Programmable Mixed-Signal Matrix with Asynchronous State Machine and Dual Supply

5.8.2 SLG46881 GPI IO Structure (for GPIs 6, 7)

Input Mode [1:0]
 00: Digital In without Schmitt Trigger, wosmt_en = 1
 01: Digital In with Schmitt Trigger, smt_en = 1
 10: Low Voltage Digital In mode, lv_en = 1
 11: Analog IO mode

Note 1: 100 ns debounce is available for GPI6 only
 Note 2: Can be varied over PVT, for reference only

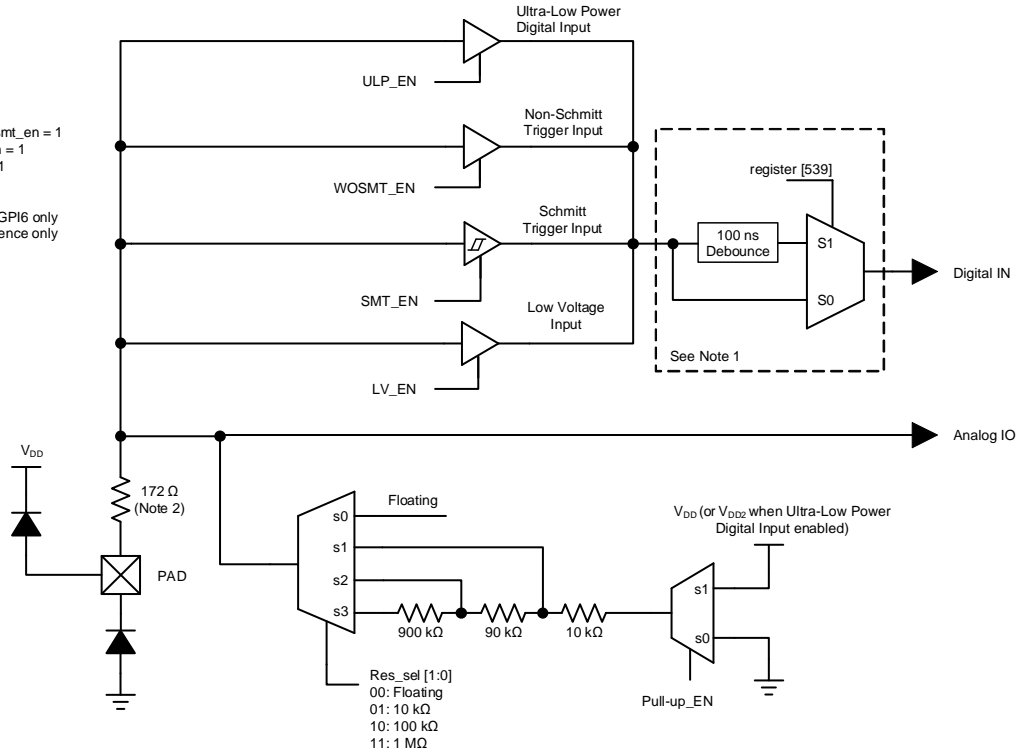

Figure 6: SLG46881 GPI IO Structure Diagram

GreenPAK Programmable Mixed-Signal Matrix with Asynchronous State Machine and Dual Supply

5.9 GPI WITH INPUT LATCH IO STRUCTURE (V_{DD})

5.9.1 SLG46880 GPI with Input LATCH IO Structure (for GPIs 0, 1)

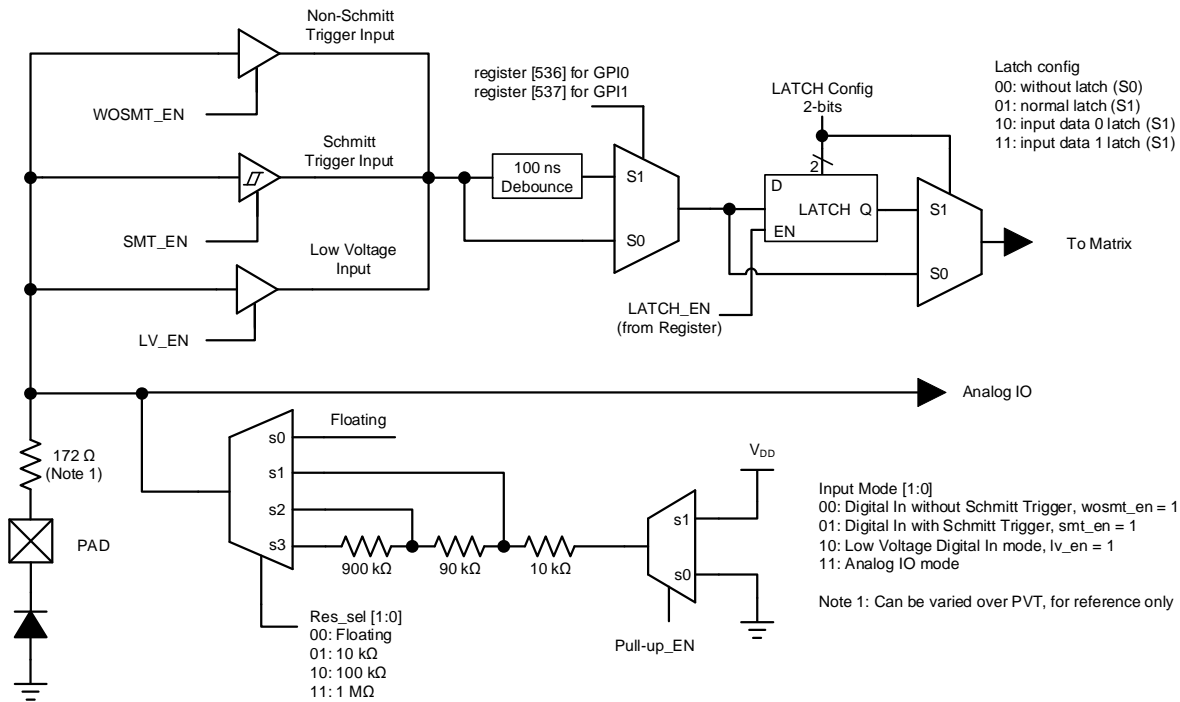

Figure 7: SLG46880 GPI with Input LATCH Structure Diagram

GreenPAK Programmable Mixed-Signal Matrix with Asynchronous State Machine and Dual Supply

5.9.2 SLG46881 GPI with Input LATCH IO Structure (for GPIs 0, 1)

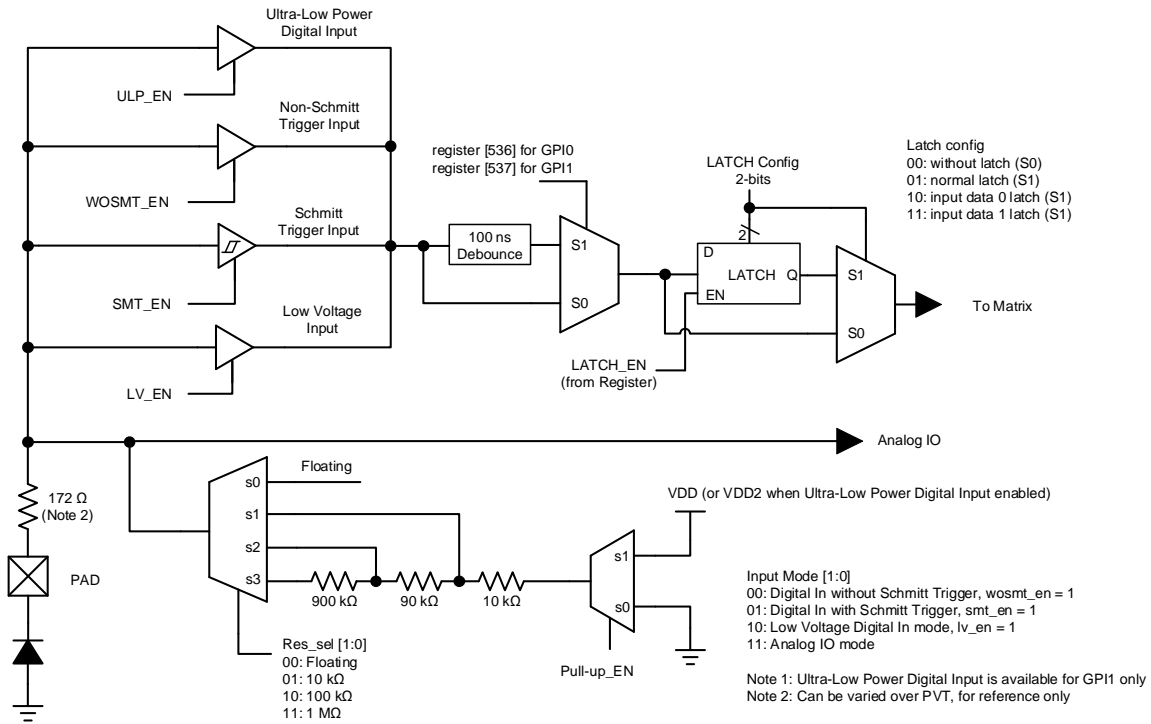

Figure 8: SLG46881 GPI with Input LATCH Structure Diagram

GreenPAK Programmable Mixed-Signal Matrix with Asynchronous State Machine and Dual Supply

5.10 GPI WITH I²C MODE IO STRUCTURE (V_{DD})

5.10.1 SLG46880 GPI with I²C Mode Structure (for GPIs 2, 3)

Input Mode [1:0]
 00: Digital In without Schmitt Trigger, wosmt_en = 1
 01: Reserved
 10: Low Voltage Digital In mode, lv_en = 1
 11: Reserved

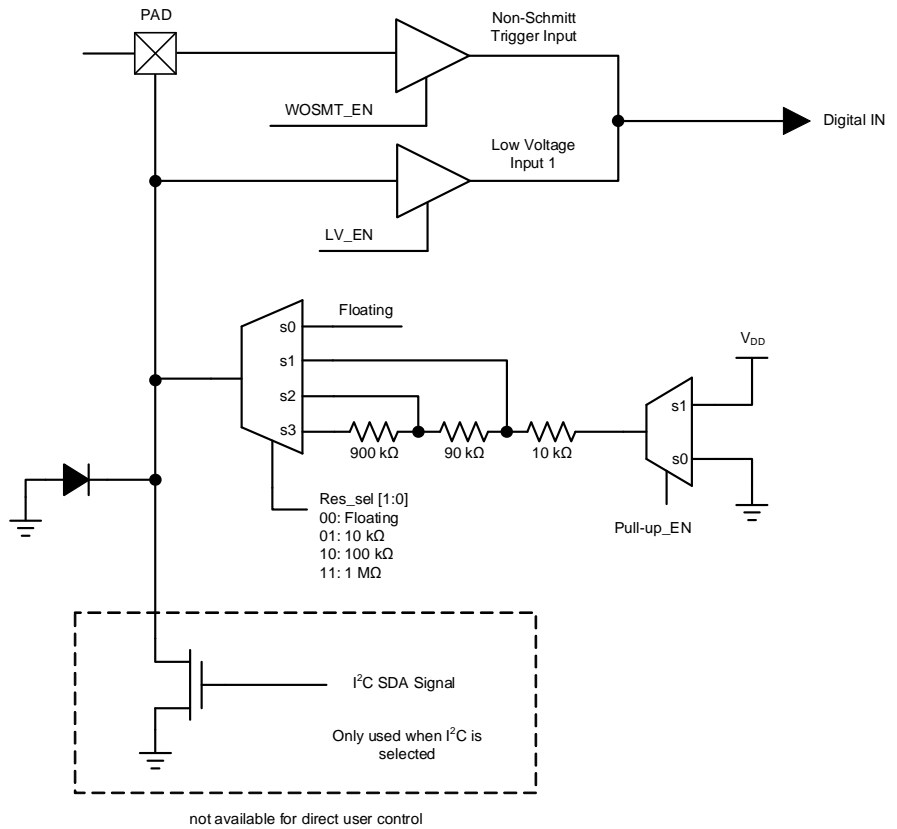

Figure 9: SLG46880 GPI with I²C Mode IO Structure Diagram

GreenPAK Programmable Mixed-Signal Matrix with Asynchronous State Machine and Dual Supply

5.10.2 SLG46881 GPI with I²C Mode Structure (for GPIs 2, 3)

Input Mode [1:0]
 00: Digital In without Schmitt Trigger, wosmt_en = 1
 01: Reserved
 10: Low Voltage Digital In mode, lv_en = 1
 11: Reserved

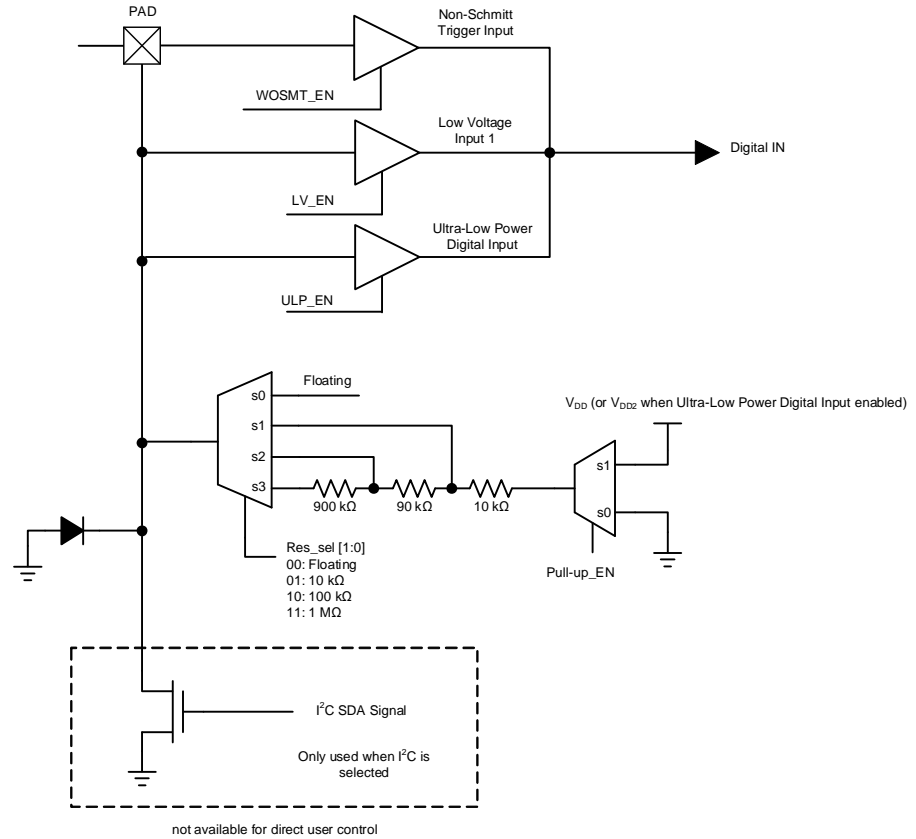

Figure 10: SLG46881 GPI with I²C Mode IO Structure Diagram

GreenPAK Programmable Mixed-Signal Matrix with Asynchronous State Machine and Dual Supply

5.11 GPIO WITH MATRIX OE IO STRUCTURE (V_{DD} OR V_{DD2})

5.11.1 SLG46880 GPIO with Matrix OE IO Structure (for GPIOs 0, 1, 8, 9, 10, 11 with V_{DD} , and GPIOs 4, 5 with V_{DD2})

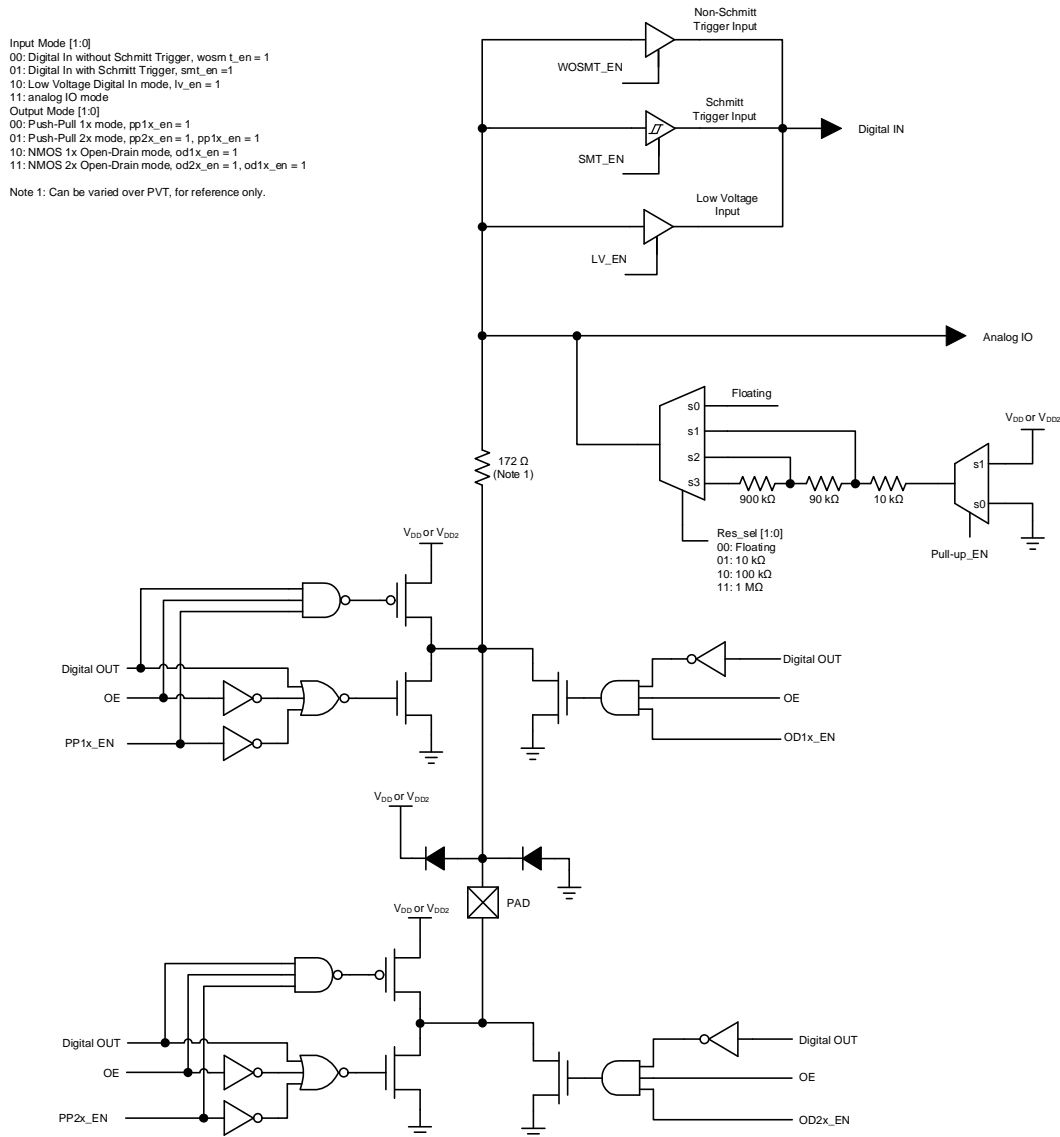

Figure 11: SLG46880 GPIO with Matrix OE IO Structure Diagram

GreenPAK Programmable Mixed-Signal Matrix with Asynchronous State Machine and Dual Supply

5.11.2 SLG46881 GPIO with Matrix OE IO Structure (for GPIOs 0, 1, 8, 9, 10, 11 with V_{DD} , and GPIOs 4, 5 with V_{DD2})

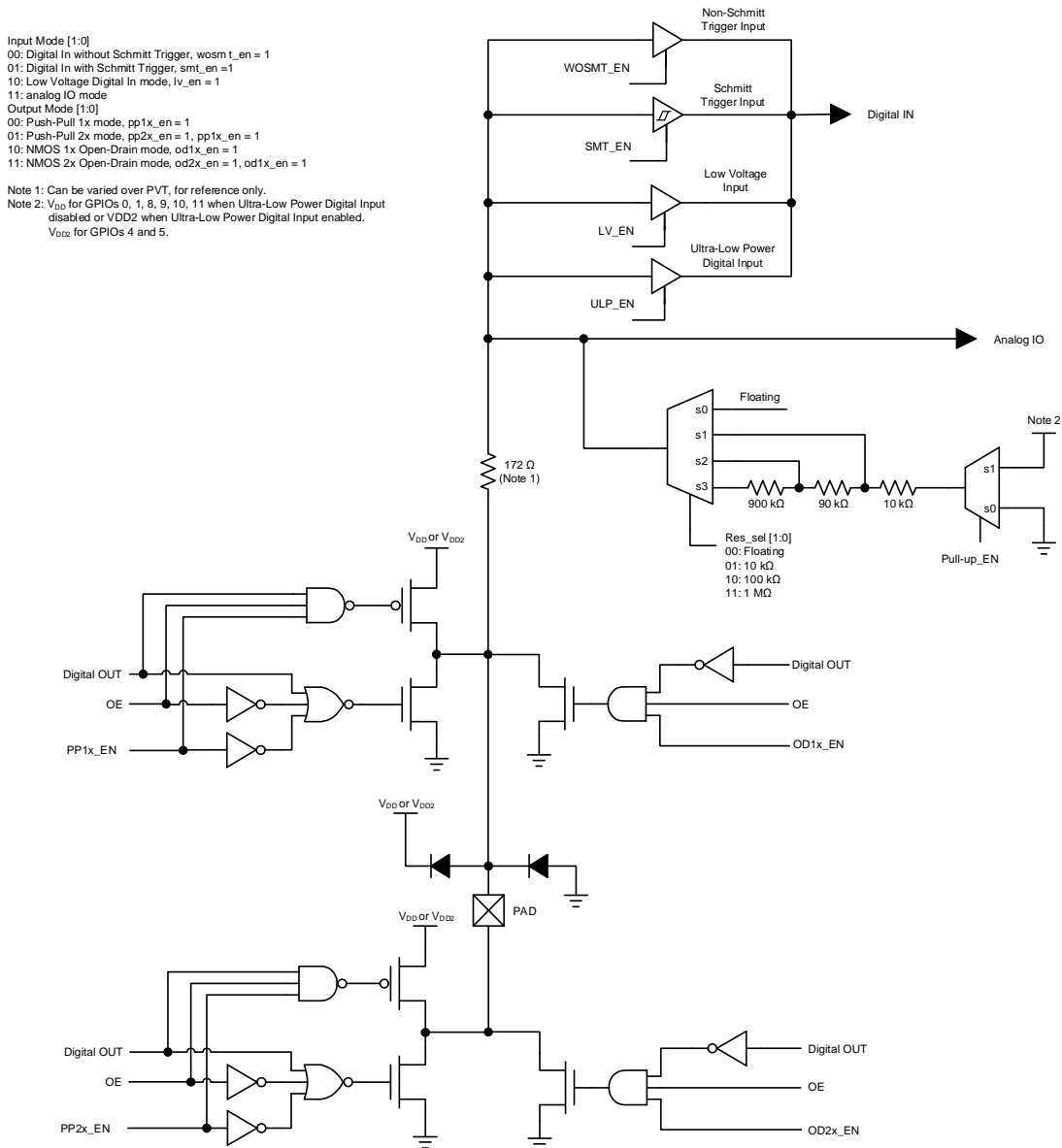

Figure 12: SLG46881 GPIO with Matrix OE IO Structure Diagram

GreenPAK Programmable Mixed-Signal Matrix with Asynchronous State Machine and Dual Supply

5.12 GPIO WITH MATRIX OE AND INPUT LATCH IO STRUCTURE (V_{DD} OR V_{DD2})

5.12.1 SLG46880 GPIO with Matrix OE and Input LATCH IO Structure (for GPIOs 2, 3 with V_{DD} , GPIOs 6, 7 with V_{DD2})

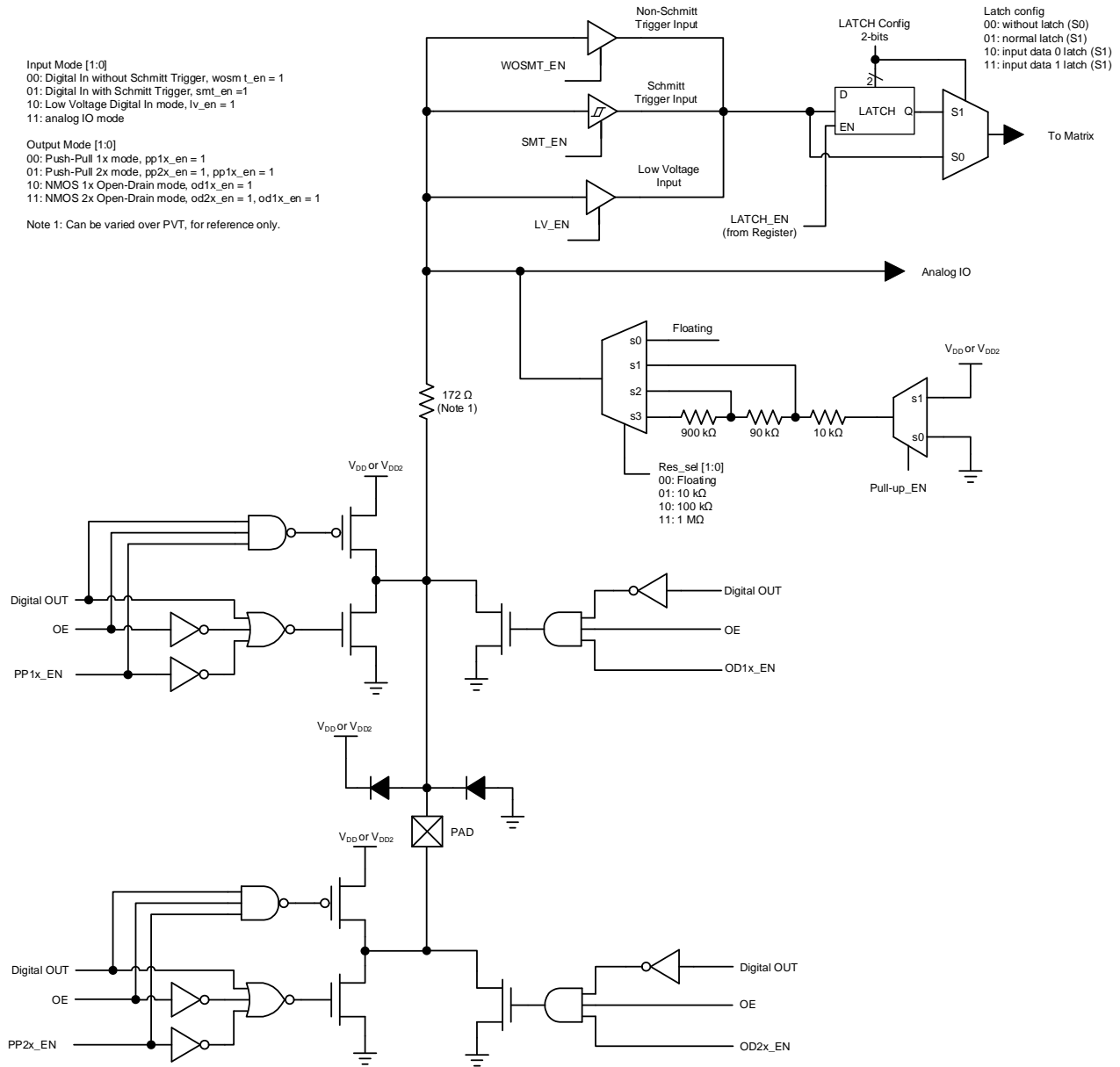

Figure 13: SLG46880 GPIO with Matrix OE and Input LATCH IO Structure Diagram

GreenPAK Programmable Mixed-Signal Matrix with Asynchronous State Machine and Dual Supply

5.12.2 SLG46881 GPIO with Matrix OE and Input LATCH IO Structure (for GPIOs 2, 3 with V_{DD} , GPIOs 6, 7 with V_{DD2})

Input Mode [1:0]
 00: Digital In without Schmitt Trigger, wosmt_en = 1
 01: Digital In with Schmitt Trigger, smt_en = 1
 10: Low Voltage Digital In mode, lv_en = 1
 11: analog IO mode

Output Mode [1:0]
 00: Push-Pull 1x mode, pp1x_en = 1
 01: Push-Pull 2x mode, pp2x_en = 1, pp1x_en = 1
 10: NMOS 1x Open-Drain mode, od1x_en = 1
 11: NMOS 2x Open-Drain mode, od2x_en = 1, od1x_en = 1

Note 1: Can be varied over PVT, for reference only.
 Note 2: V_{DD} for GPIOs 0, 1, 8, 9, 10, 11 when Ultra-Low Power Digital Input disabled or V_{DD2} when Ultra-Low Power Digital Input enabled.
 V_{DD2} for GPIOs 4 and 5.

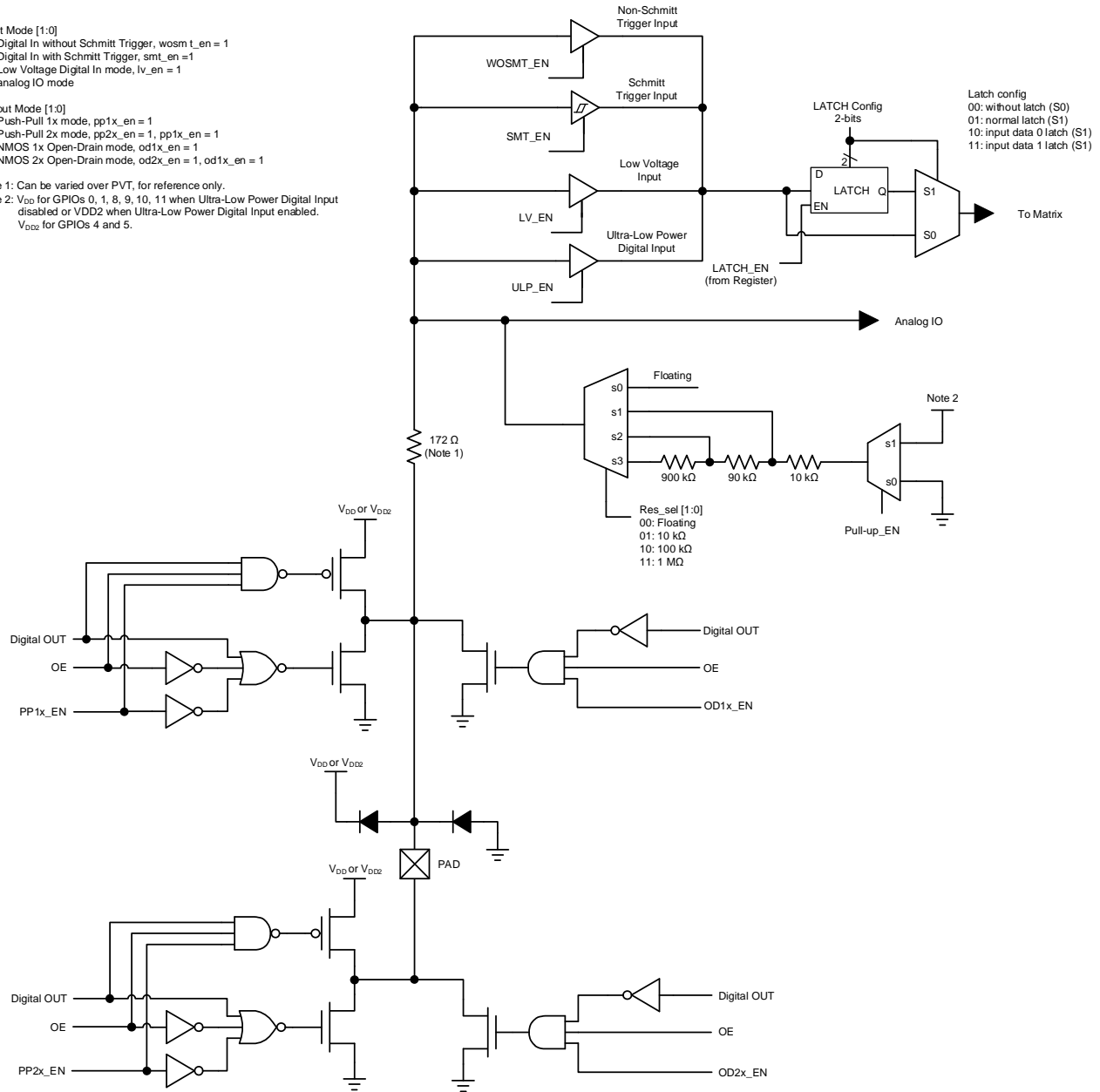

Figure 14: SLG46881 GPIO with Matrix OE and Input LATCH IO Structure Diagram

GreenPAK Programmable Mixed-Signal Matrix with Asynchronous State Machine and Dual Supply

5.13 GPI WITH INPUT LATCH AND CRYSTAL INPUT IO STRUCTURE (V_{DD})

5.13.1 SLG46880 GPI with Input LATCH and Crystal Input IO Structure (for GPIs 4, 5)

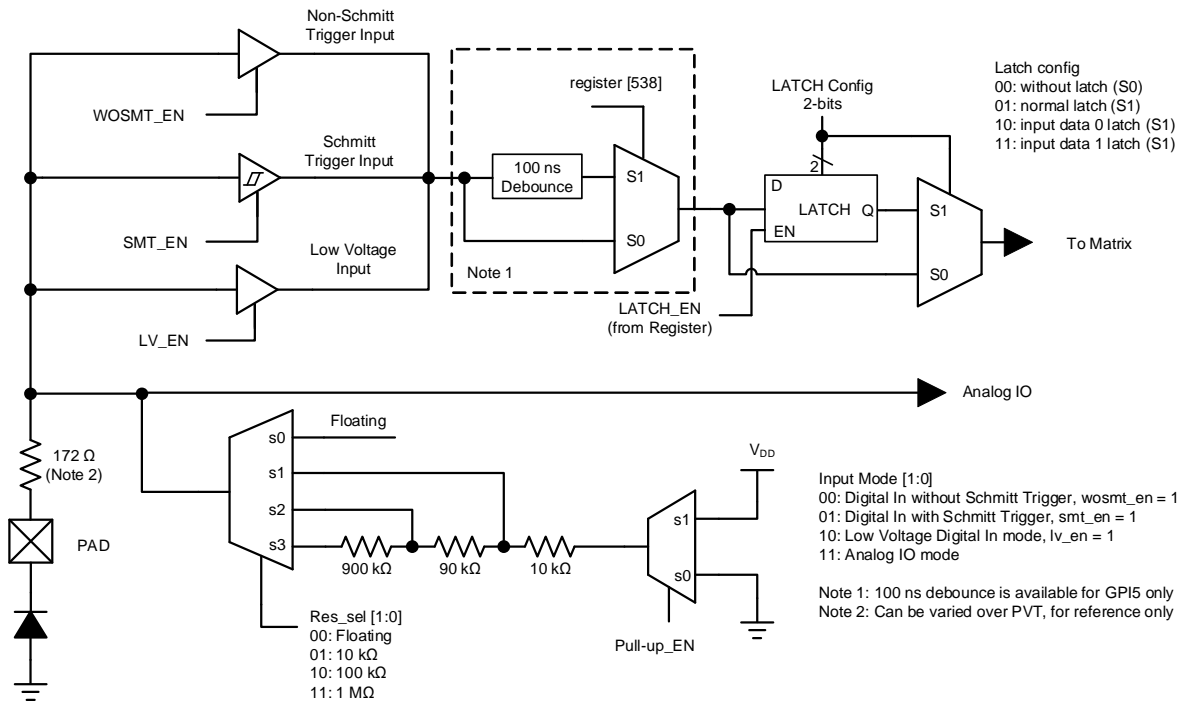

Figure 15: SLG46880 GPI with Input LATCH and Crystal Input IO Structure Diagram

GreenPAK Programmable Mixed-Signal Matrix with Asynchronous State Machine and Dual Supply

5.13.2 SLG46881 GPI with Input LATCH and Crystal Input IO Structure (for GPIs 4, 5)

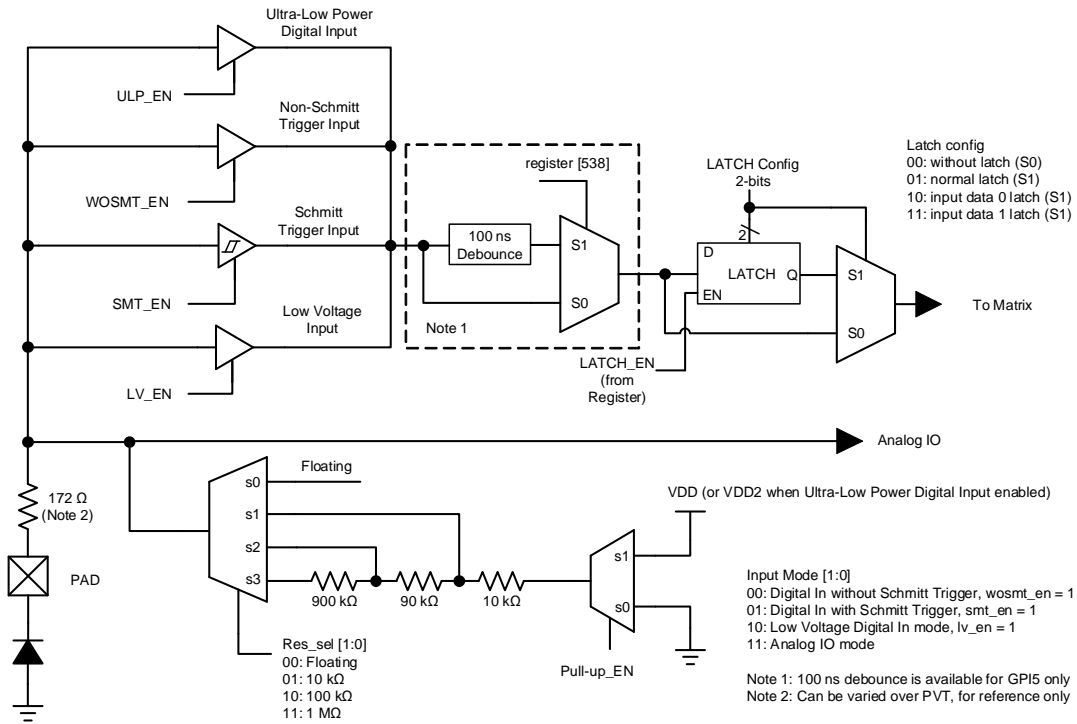

Figure 16: SLG46881 GPI with Input LATCH and Crystal Input IO Structure Diagram

GreenPAK Programmable Mixed-Signal Matrix with Asynchronous State Machine and Dual Supply

5.14 GPO REGISTER OE IO STRUCTURE (V_{DD} OR V_{DD2})

5.14.1 GPO Register OE IO Structure (for GPOs 0, 5, 6, 7 for V_{DD} , and GPOs 1, 2, 3, 4 for V_{DD2})

Output Mode [1:0]
 00: Push-Pull 1x mode, pp1x_en = 1
 01: Push-Pull 2x mode, pp2x_en = 1, pp1x_en = 1
 10: NMOS 1x Open-Drain mode, od1x_en = 1
 11: NMOS 2x Open-Drain mode, od2x_en = 1, od1x_en = 1

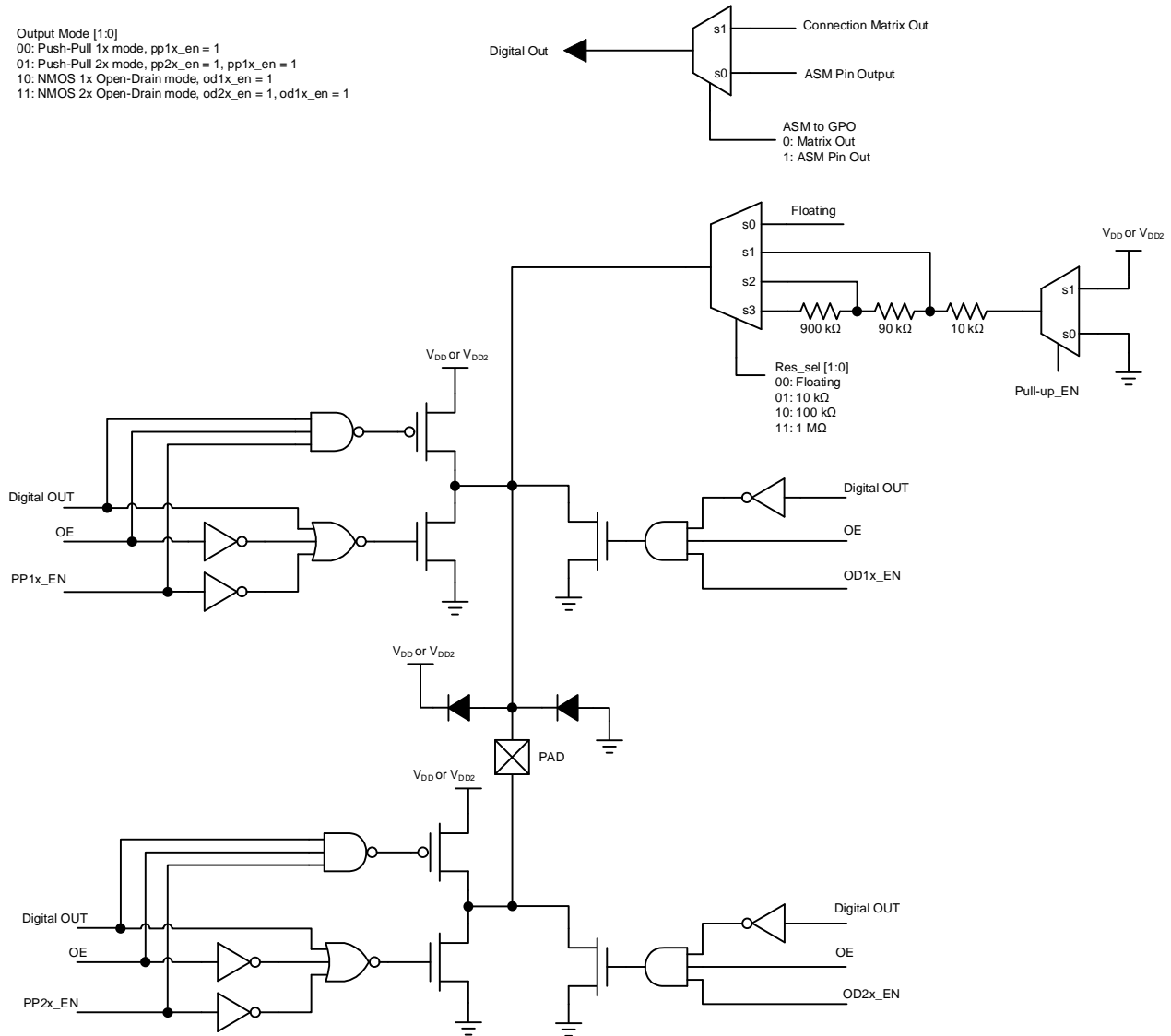

Figure 17: SLG46880/81 GPO Register OE IO Structure Diagram

GreenPAK Programmable Mixed-Signal Matrix with Asynchronous State Machine and Dual Supply

5.15 IO TYPICAL PERFORMANCE

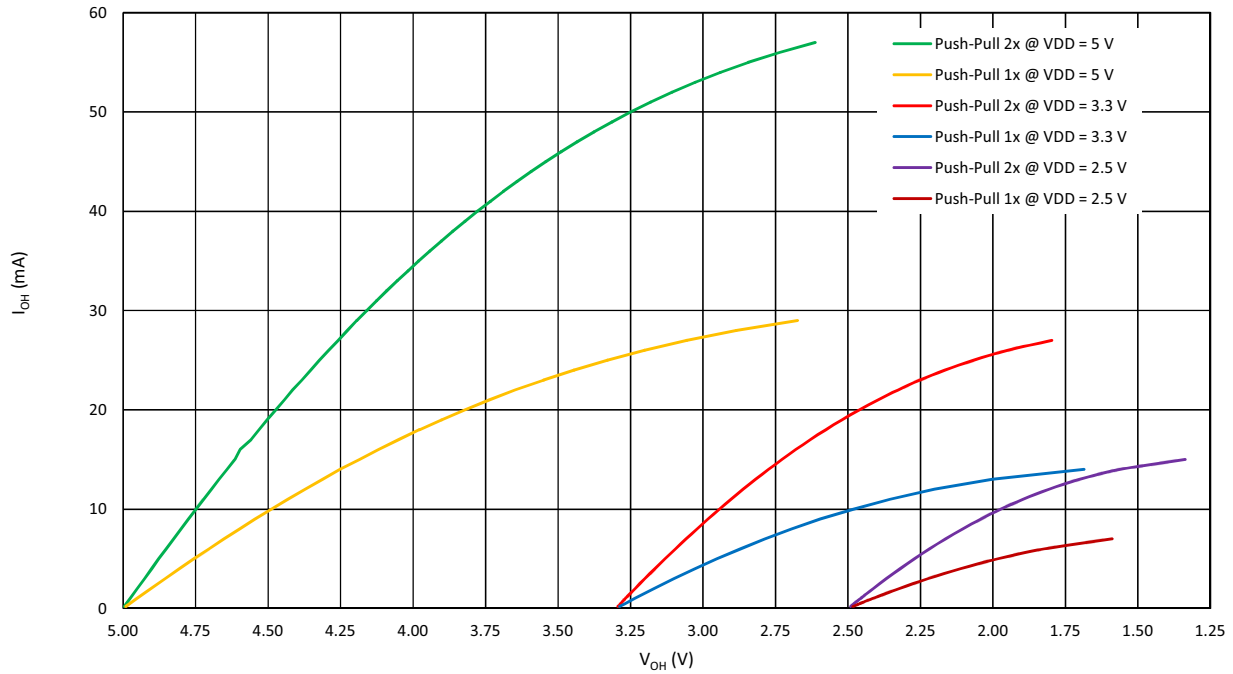

Figure 18: Typical High Level Output Current vs. High Level Output Voltage at T = 25 °C

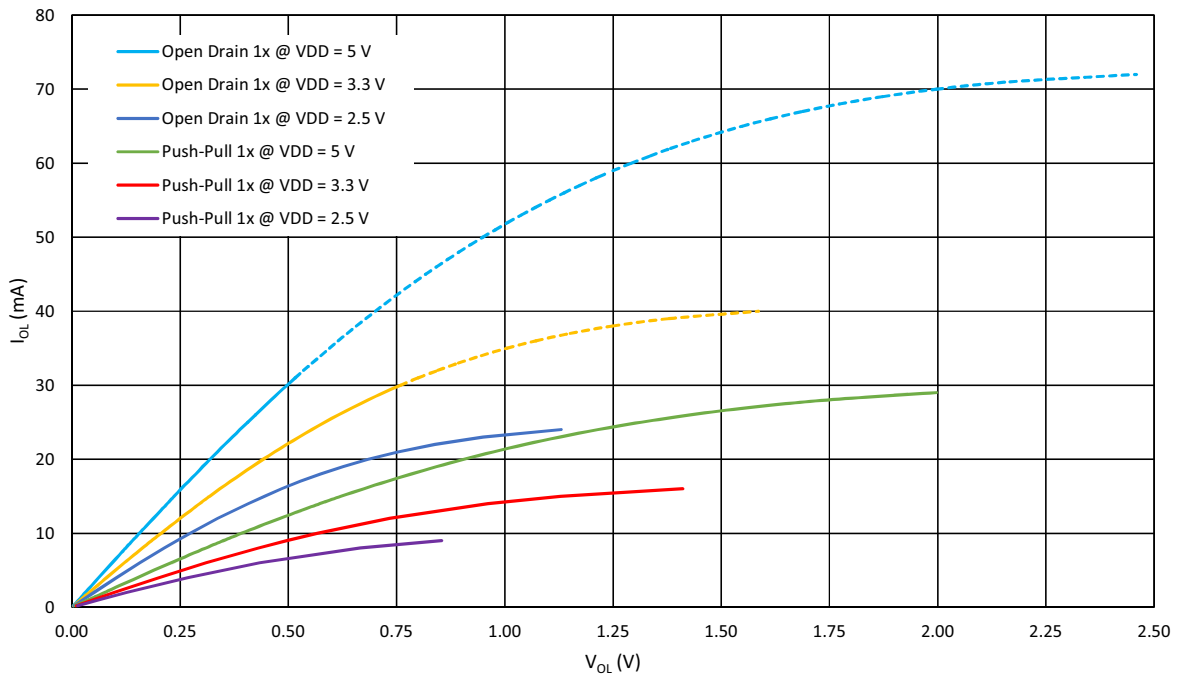

Figure 19: Typical Low Level Output Current vs. Low Level Output Voltage, 1x Drive at T = 25 °C, Full Range

GreenPAK Programmable Mixed-Signal Matrix with Asynchronous State Machine and Dual Supply

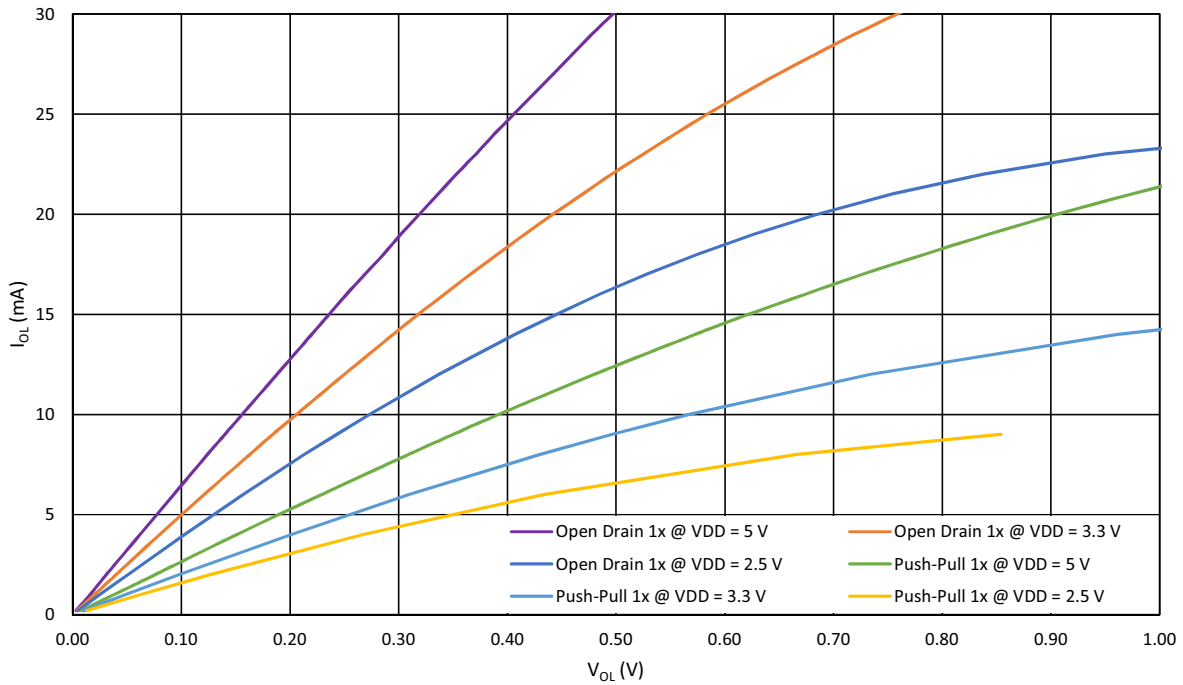

Figure 20: Typical Low Level Output Current vs. Low Level Output Voltage, 1x Drive at T = 25 °C

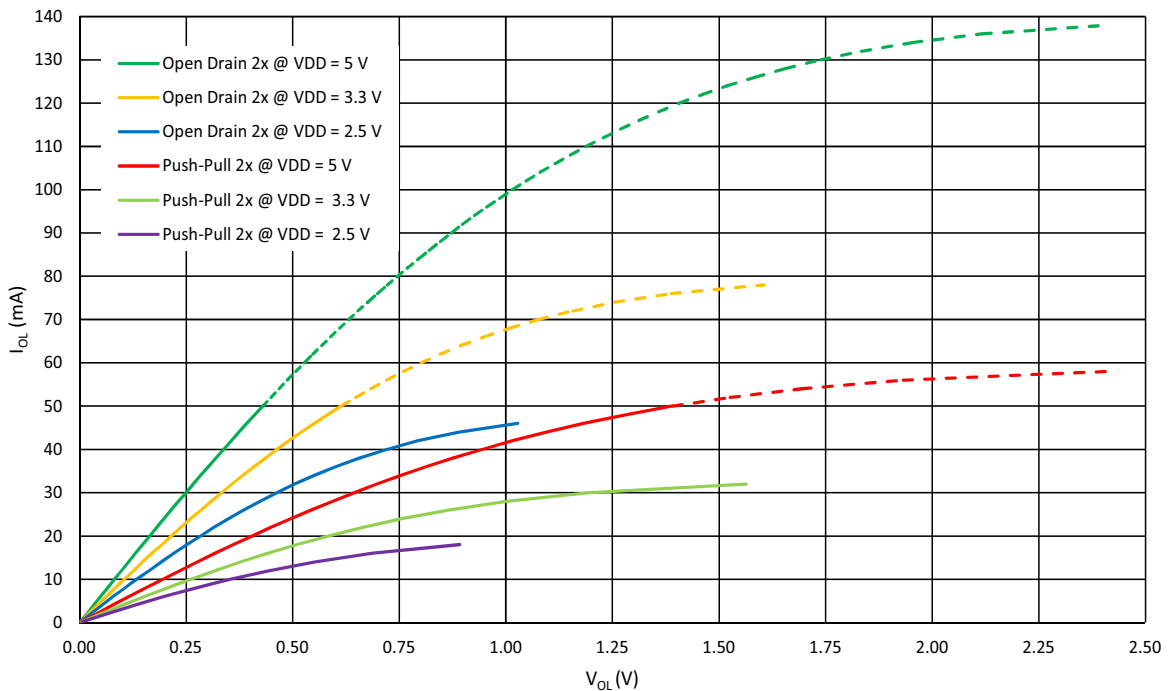

Figure 21: Typical Low Level Output Current vs. Low Level Output Voltage, 2x Drive at T = 25 °C, Full Range

GreenPAK Programmable Mixed-Signal Matrix with Asynchronous State Machine and Dual Supply

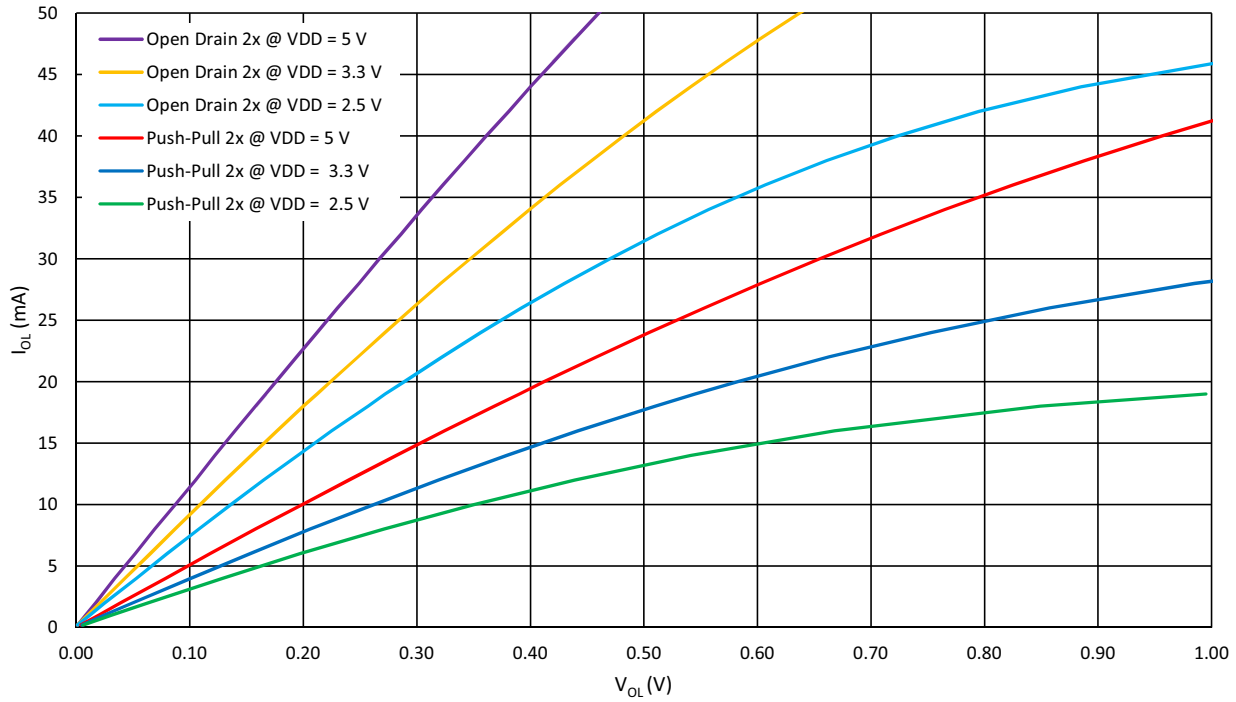

Figure 22: Typical Low Level Output Current vs. Low Level Output Voltage, 2x Drive at T = 25 °C

6 Connection Matrix

The Connection Matrix in the SLG46880/81 is used to create the internal routing for internal functional macrocells of the device once it is programmed. The registers are programmed from the one-time NVM cell during Test Mode Operation. The output of each functional macrocell within the SLG46880/81 has a specific digital bit code assigned to it that is either set to active “High” or inactive “Low”, based on the design that is created. Once the 4096 register bits within the SLG46880/81 are programmed a fully custom circuit will be created.

The Connection Matrix has 64 inputs, 84 outputs and 17 state dependent outputs. Each of the 64 inputs to the Connection Matrix is hard-wired to the digital output of a particular source macrocell, including IO pins, LUTs, analog comparators, other digital resources, such as V_{DD} and GND. The input to a digital macrocell uses a 6-bit register to select one of these 64 input lines.

For a complete list of the SLG46880/81’s register table, see Section 21.

Matrix Input Signal Functions	N				
GND	0				
GPIO0 Digital In	1				
GPIO1 Digital In	2				
GPIO2 Digital In	3				
⋮	⋮				
nRST_core (POR)	62				
V_{DD}	63				

Matrix Inputs	N	0	1	2	⋮	83
Registers		register [5:0]	register [11:6]	register [17:12]	⋮	registers [503:498]
Function		Matrix OUT: IN0 of LUT2_0 or Clock Input of DFF0	Matrix OUT: IN1 of LUT2_0 or Data Input of DFF0	Matrix Out: IN0 of LUT2_1 or Clock Input of PGen	⋮	DM EXT CLK1

Figure 23: Connection Matrix

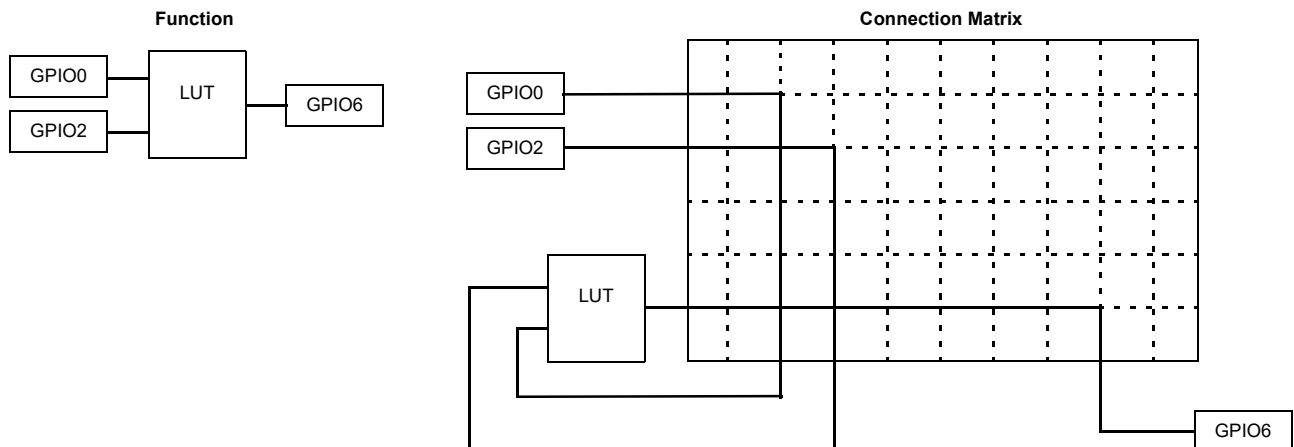

Figure 24: Connection Matrix Example

GreenPAK Programmable Mixed-Signal Matrix with Asynchronous State Machine and Dual Supply

6.1 MATRIX INPUT TABLE

Table 29: Matrix Input Table

Matrix Input Number	Matrix Input Signal Function	Matrix Decode					
		5	4	3	2	1	0
0	GND	0	0	0	0	0	0
1	GPIO0 Digital Input	0	0	0	0	0	1
2	GPIO1 Digital Input	0	0	0	0	1	0
3	GPIO2 Digital Input	0	0	0	0	1	1
4	GPIO Digital Input	0	0	0	1	0	0
5	GPI1 Digital Input	0	0	0	1	0	1
6	GPIO3 Digital Input	0	0	0	1	1	0
7	GPIO4 Digital Input	0	0	0	1	1	1
8	LUT2_0/DFF0 Output	0	0	1	0	0	0
9	LUT2_1/PGen Output	0	0	1	0	0	1
10	LUT3_0/DFF1 Output	0	0	1	0	1	0
11	LUT3_1/DFF2 Output	0	0	1	0	1	1
12	LUT3_2/DFF3 Output	0	0	1	1	0	0
13	LUT3_3/DFF4 Output	0	0	1	1	0	1
14	LUT3_4/CNT_DLY1(8bit) Output	0	0	1	1	1	0
15	LUT3_5/CNT_DLY2(8bit) Output	0	0	1	1	1	1
16	LUT3_6/CNT_DLY3(8bit) Output	0	1	0	0	0	0
17	LUT3_7/CNT_DLY4(8bit) Output	0	1	0	0	0	1
18	LUT4_0/CNT_DLY0(16bit) Output	0	1	0	0	1	0
19	LUT3_8/Pipe Delay Output0/Ripple CNT Output0	0	1	0	0	1	1
20	Pipe Delay Output1/Ripple CNT Output1	0	1	0	1	0	0
21	Internal 2.048 MHz Osc Output	0	1	0	1	0	1
22	Internal 2.048 kHz Osc Output	0	1	0	1	1	0
23	Internal 25 MHz Osc Output	0	1	0	1	1	1
24	Filter/Edge Detect Output/Ripple CNT Output2	0	1	1	0	0	0
25	Programmable Delay with Edge Detector Output	0	1	1	0	0	1
26	F(1) Function Output0	0	1	1	0	1	0
27	F(1) Function Output1	0	1	1	0	1	1
28	F(1) Function Output2	0	1	1	1	0	0
29	DM0_0 Macrocell Output0	0	1	1	1	0	1
30	DM0_0 Macrocell Output1	0	1	1	1	1	0
31	DM0_0 Macrocell Output2	0	1	1	1	1	1
32	GPI2/SDA Digital Input or I ² C_virtual_0 Input	1	0	0	0	0	0
33	GPI3/SCL Digital Input or I ² C_virtual_1 Input	1	0	0	0	0	1
34	I ² C_virtual_2 Input	1	0	0	0	1	0
35	I ² C_virtual_3 Input	1	0	0	0	1	1
36	I ² C_virtual_4 Input	1	0	0	1	0	0
37	I ² C_virtual_5 Input	1	0	0	1	0	1

GreenPAK Programmable Mixed-Signal Matrix with Asynchronous State Machine and Dual Supply

Table 29: Matrix Input Table(Continued)

Matrix Input Number	Matrix Input Signal Function	Matrix Decode					
		5	4	3	2	1	0
38	I ² C_virtual_6 Input	1	0	0	1	1	0
39	I ² C_virtual_7 Input	1	0	0	1	1	1
40	DM0_1 Macrocell Output0	1	0	1	0	0	0
41	DM0_1 Macrocell Output1	1	0	1	0	0	1
42	DM0_1 Macrocell Output2	1	0	1	0	1	0
43	ASM Connection Matrix Output RAM 0	1	0	1	0	1	1
44	ASM Connection Matrix Output RAM 1	1	0	1	1	0	0
45	ASM Connection Matrix Output RAM 2	1	0	1	1	0	1
46	ASM Connection Matrix Output RAM 0	1	0	1	1	1	0
47	GPIO5 Digital Input	1	0	1	1	1	1
48	GPIO6 Digital Input	1	1	0	0	0	0
49	GPIO7 Digital Input	1	1	0	0	0	1
50	GPIO8 Digital Input	1	1	0	0	1	0
51	GPI4 Digital Input/Crystal OSC	1	1	0	0	1	1
52	GPI5 Digital Input	1	1	0	1	0	0
53	GPI6 Digital Input	1	1	0	1	0	1
54	GPI7 Digital Input	1	1	0	1	1	0
55	GPIO9 Digital Input	1	1	0	1	1	1
56	ACMP0H Output	1	1	1	0	0	0
57	ACMP1H Output	1	1	1	0	0	1
58	ACMP2L Output	1	1	1	0	1	0
59	ACMP3L output	1	1	1	0	1	1
60	GPIO10 Digital Input	1	1	1	1	0	0
61	GPIO11 Digital Input	1	1	1	1	0	1
62	nRST_core (POR) as matrix input	1	1	1	1	1	0
63	V _{DD}	1	1	1	1	1	1

6.2 MATRIX OUTPUT TABLE

Table 30: Matrix Output Table

Register Bit Address	Matrix Output Signal Function	Matrix Output Number
[5:0]	Matrix Out 0: IN0 of LUT2_0 or Clock Input of DFF0	0
[11:6]	Matrix Out 1: IN1 of LUT2_0 or Data Input of DFF0	1
[17:12]	Matrix Out 2: IN0 of LUT2_1 or Clock Input of PGen	2
[23:18]	Matrix Out 3: IN1 of LUT2_1 or nRST of PGen	3
[29:24]	Matrix Out 4: IN0 of LUT3_0 or Clock Input of DFF1	4
[35:30]	Matrix Out 5: IN1 of LUT3_0 or Data Input of DFF1	5
[41:36]	Matrix Out 6: IN2 of LUT3_0 or nRST (nSET) of DFF1	6
[47:42]	Matrix Out 7: IN0 of LUT3_1 or Clock Input of DFF2	7
[53:48]	Matrix Out 8: IN1 of LUT3_1 or Data Input of DFF2	8

GreenPAK Programmable Mixed-Signal Matrix with Asynchronous State Machine and Dual Supply

Table 30: Matrix Output Table(Continued)

Register Bit Address	Matrix Output Signal Function	Matrix Output Number
[59:54]	Matrix Out 9: IN2 of LUT3_1 or nRST (nSET) of DFF2	9
[65:60]	Matrix Out 10: IN0 of LUT3_2 or Clock Input of DFF3	10
[71:66]	Matrix Out 11: IN1 of LUT3_2 or Data Input of DFF3	11
[77:72]	Matrix Out 12: IN2 of LUT3_2 or nRST (nSET) of DFF3	12
[83:78]	Matrix Out 13: IN0 of LUT3_3 or Clock Input of DFF4	13
[89:84]	Matrix Out 14: IN1 of LUT3_3 or Data Input of DFF4	14
[95:90]	Matrix Out 15: IN2 of LUT3_3 or nRST (nSET) of DFF4	15
[101:96]	Matrix Out 16:IN0 of LUT3_4 or Delay1 Input (or Counter1 nRST Input)	16
[107:102]	Matrix Out 17:IN1 of LUT3_4 or External Clock1 Input of Delay1 (or Counter1)	17
[113:108]	Matrix Out 18:IN2 of LUT3_4	18
[119:114]	Matrix Out 19:IN0 of LUT3_5 or Delay2 Input (or Counter2 nRST Input)	19
[125:120]	Matrix Out 20:IN1 of LUT3_5 or External Clock1 Input of Delay2 (or Counter2)	20
[131:126]	Matrix Out 21:IN2 of LUT3_5	21
[137:132]	Matrix Out 22:IN0 of LUT3_6 or Delay3 Input (or Counter3 nRST Input)	22
[143:138]	Matrix Out 23:IN1 of LUT3_6 or External Clock1 Input of Delay3 (or Counter3)	23
[149:144]	Matrix Out 24:IN2 of LUT3_6	24
[155:150]	Matrix Out 25:IN0 of LUT3_7 or Delay4 Input (or Counter4 nRST Input)	25
[161:156]	Matrix Out 26:IN1 of LUT3_7 or External Clock1 Input of Delay4 (or Counter4)	26
[167:162]	Matrix Out 27:IN2 of LUT3_7	27
[173:168]	Matrix Out 28:IN0 of LUT3_8 or Input of Pipe Delay	28
[179:174]	Matrix Out 29:IN1 of LUT3_8 or nRST of Pipe Delay	29
[185:180]	Matrix Out 30:IN2 of LUT3_8 or Clock of Pipe Delay	30
[191:186]	Matrix Out 31:IN0 of LUT4_0 or Delay0 Input (or Counter0 nRST Input)	31
[197:192]	Matrix Out 32:IN1 of LUT4_0 or External Clock Input of Delay0 (or Counter0)	32
[203:198]	Matrix Out 33:IN2 of LUT4_0 or UP Input of FSM0	33
[209:204]	Matrix Out 34:IN3 of LUT4_0 or KEEP Input of FSM0	34
[215:210]	Matrix Out 35: ACMP0H Power-down	35
[221:216]	Matrix Out 36: ACMP1H Power-down	36
[227:222]	Matrix Out 37: ACMP2L Power-down	37
[233:228]	Matrix Out 38: ACMP3L Power-down	38
[239:234]	Matrix Out 39: GPO7 DOUT	39
[245:240]	Matrix Out 40: GPO0 DOUT	40
[251:246]	Matrix Out 41: GPIO0 DOUT	41
[257:252]	Matrix Out 42: GPIO0 DOUT OE	42
[263:258]	Matrix Out 43: GPIO1 DOUT	43
[269:264]	Matrix Out 44: GPIO1 DOUT OE	44
[275:270]	Matrix Out 45: GPIO2 DOUT	45
[281:276]	Matrix Out 46: GPIO2 DOUT OE	46
[287:282]	Matrix Out 47: GPIO3 DOUT	47

GreenPAK Programmable Mixed-Signal Matrix with Asynchronous State Machine and Dual Supply

Table 30: Matrix Output Table(Continued)

Register Bit Address	Matrix Output Signal Function	Matrix Output Number
[293:288]	Matrix Out 48: GPIO3 DOUT OE	48
[299:294]	Matrix Out 49: GPIO4 DOUT	49
[305:300]	Matrix Out 50: GPIO4 DOUT OE	50
[311:306]	Matrix Out 51: GPIO5 DOUT	51
[317:312]	Matrix Out 52: GPIO5 DOUT OE	52
[323:318]	Matrix Out 53: GPO1 DOUT	53
[329:324]	Matrix Out 54: GPO2 DOUT	54
[335:330]	Matrix Out 55: GPO3 DOUT	55
[341:336]	Matrix Out 56: GPO4 DOUT	56
[347:342]	Matrix Out 57: GPIO6 DOUT OE	57
[353:348]	Matrix Out 58: GPIO6 DOUT	58
[359:354]	Matrix Out 59: GPIO7 DOUT	59
[365:360]	Matrix Out 60: GPIO7 DOUT OE	60
[371:366]	Matrix Out 61: GPIO8 DOUT OE	61
[377:372]	Matrix Out 62: GPIO8 DOUT	62
[383:378]	Matrix Out 63: GPIO9 DOUT OE	63
[389:384]	Matrix Out 64: GPIO9 DOUT	64
[395:390]	Matrix Out 65: GPIO10 DOUT OE	65
[401:396]	Matrix Out 66: GPIO10 DOUT	66
[407:402]	Matrix Out 67: GPIO11 DOUT OE	67
[413:408]	Matrix Out 68: GPIO11 DOUT	68
[419:414]	Matrix Out 69: GPO5 DOUT	69
[425:420]	Matrix Out 70: GPO6 DOUT	70
[431:426]	Matrix Out 71: ASM nRST	71
[437:432]	Matrix Out 72: OSC0 ENABLE	72
[443:438]	Matrix Out 73: OSC1 ENABLE	73
[449:444]	Matrix Out 74: OSC2 ENABLE	74
[455:450]	Matrix Out 75: Filter/Edge detect input	75
[461:456]	Matrix Out 76: F1 interrupt	76
[467:462]	Matrix Out 77: Programmable delay/edge detect input	77
[473:468]	Matrix Out 78: Temp sensor/Crystal OSC/Vref Out_0/Vref Out_1 Power Up	78
[479:474]	Matrix Out 79: GPI LATCH enable	79
[485:480]	Matrix Out 80: GPIO LATCH enable	80
[491:486]	Matrix Out 81: BG enable	81
[497:492]	DM_EXT_CLK0	82
[503:498]	DM_EXT_CLK1	83

Note: For each Address, the two most significant bits are unused.

GreenPAK Programmable Mixed-Signal Matrix with Asynchronous State Machine and Dual Supply

6.3 CONNECTION MATRIX VIRTUAL INPUTS

As mentioned previously, the Connection Matrix inputs come from the outputs of various digital macrocells on the device. Eight of the Connection Matrix inputs have the special characteristic that the state of these signal lines comes from a corresponding data bit written as a register value via I²C. This gives the user the ability to write data via the serial channel, and have this information translated into signals that can be driven into the Connection Matrix and from the Connection Matrix to the digital inputs of other macrocells on the device. The I²C address for reading and writing these register values is at 0x1DB (475).

Six of the eight Connection Matrix Virtual Inputs are dedicated to this virtual input function. An I²C write command to these register bits will set the signal values going into the Connection Matrix to the desired state. A read command to these register bits will read either the original data values coming from the NVM memory bits (that were loaded during the initial device startup), or the values from a previous write command (if that has happened).

Two of the eight Connection Matrix Virtual Inputs are shared with Pin digital inputs (GPI3/SCL Digital Input or I²C_virtual_1 Input), and (GPI2/SDA Digital Input or I²C_virtual_0 Input). If the virtual input mode is selected, an I²C write command to these register bits will set the signal values going into the Connection Matrix to the desired state. A read command to these register bits will read either the original data values coming from the NVM memory bits (that were loaded during the initial device startup), or the values from a previous write command (if that has happened). The I²C disable/enable register bit [4084] selects whether the Connection Matrix input comes from the Pin input or from the virtual register.

- Select SCL & Virtual Input 1 or GPI3/SCL.
- Select SDA & Virtual Input 0 or GPI2/SDA.

See [Table 31](#) for Connection Matrix Virtual Inputs.

Table 31: Connection Matrix Virtual Inputs

Matrix Input Number	Matrix Input Signal Function	Register Bit Addresses (d)
32	I ² C_virtual_0 Input	[3800]
33	I ² C_virtual_1 Input	[3801]
34	I ² C_virtual_2 Input	[3802]
35	I ² C_virtual_3 Input	[3803]
36	I ² C_virtual_4 Input	[3804]
37	I ² C_virtual_5 Input	[3805]
38	I ² C_virtual_6 Input	[3806]
39	I ² C_virtual_7 Input	[3807]

6.4 CONNECTION MATRIX VIRTUAL OUTPUTS

The digital outputs of the various macrocells are routed to the Connection Matrix to enable interconnections to the inputs of other macrocells in the device. At the same time, it is possible to read the state of each of the macrocell outputs as a register value via I²C. This option, called Connection Matrix Virtual Outputs, allows the user to remotely read the values of each macrocell output. The I²C addresses for reading these register values are 0x1D7 (471) to 0x1DE (478). Write commands to these same register values will be ignored (with the exception of the Virtual Input register bits at 0x1DB (475)).

7 Combination Function Macrocells

The SLG46880/81 has 12 combination function macrocells that can serve more than one logic or timing function. In each case, they can serve as a Look Up Table (LUT), or as another logic or timing function. See the list below for the functions that can be implemented in these macrocells.

- One macrocell that can serve as either 2-bit LUT or as D Flip-Flop
- Four macrocells that can serve as either 3-bit LUTs or as D Flip-Flops with Set/Reset Input
- One macrocell that can serve as either 3-bit LUT or as Pipe Delay/Ripple Counter
- One macrocell that can serve as either 2-bit LUT or as Programmable Pattern Generator (PGen)
- One macrocell that can serve as either 4-bit LUT or as 16-Bit Counter/Delay/FSM
- Four macrocells that can serve as either 3-bit LUTs or as 8-Bit Counter/Delays

Inputs/Outputs for the 12 combination function macrocells are configured from the connection matrix with specific logic functions which are defined by the state of NVM bits.

When used as a LUT to implement combinatorial logic functions, the outputs of the LUTs can be configured to any user defined function, including the following standard digital logic devices (AND, NAND, OR, NOR, XOR, XNOR). Inputs/Outputs for the 11 combination function macrocells are configured from the connection matrix with specific logic functions being defined by the state of NVM bits.

7.1 2-BIT LUT OR D FLIP-FLOP MACROCELLS

There is one macrocell that can serve as either 2-bit LUT or as D Flip-Flop. When used to implement LUT functions, the 2-bit LUT takes in two input signals from the connection matrix and produces a single output, which goes back into the connection matrix. When used to implement D Flip-Flop function, the two input signals from the connection matrix go to the data (D) and clock (CLK) inputs for the Flip-Flop, with the output going back to the connection matrix.

The operation of the D Flip-Flop and LATCH will follow the functional descriptions below:

- DFF: CLK is rising edge triggered, then Q = D; otherwise Q will not change
- LATCH: when CLK is Low, then Q = D; otherwise Q remains its previous value (input D has no effect on the output, when CLK is High).

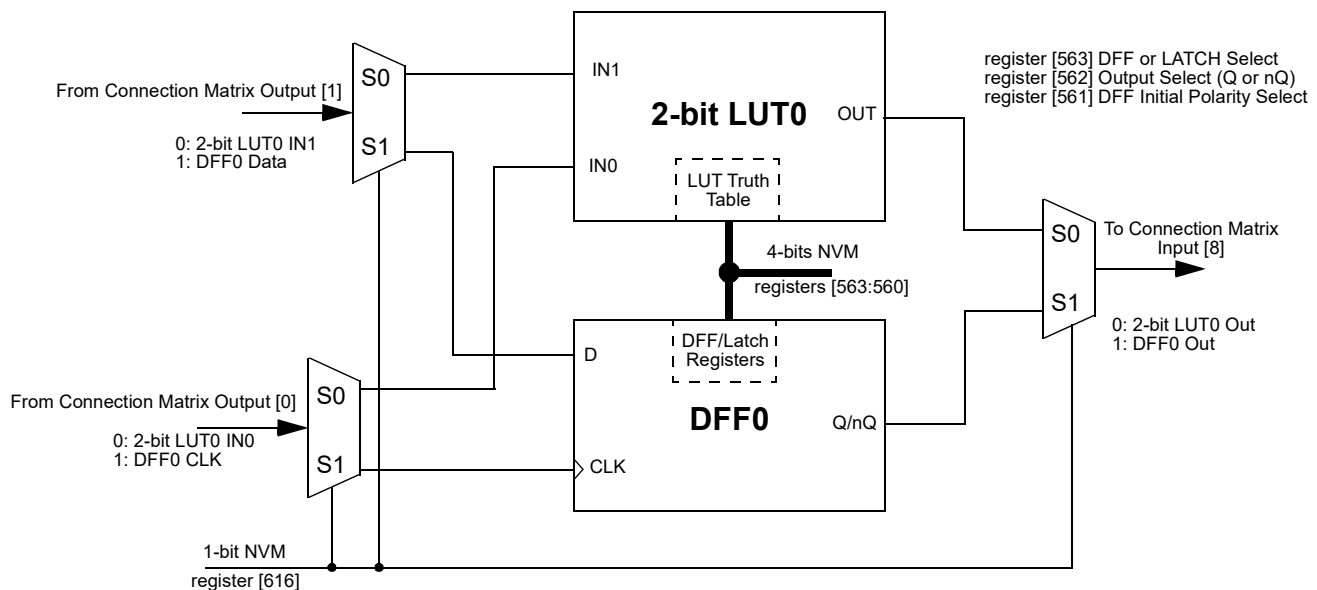

Figure 25: 2-bit LUT0 or DFF0

GreenPAK Programmable Mixed-Signal Matrix with Asynchronous State Machine and Dual Supply

7.1.1 2-Bit LUT or D Flip-Flop Macrocell Used as 2-Bit LUT

Table 32: 2-bit LUT0 Truth Table

IN1	IN0	OUT	
0	0	register [560]	LSB
0	1	register [561]	
1	0	register [562]	
1	1	register [563]	MSB

This macrocell, when programmed for a LUT function, uses a 4-bit register to define their output function:

2-Bit LUT0 is defined by registers [563:560]

Table 33 shows the register bits for the standard digital logic devices (AND, NAND, OR, NOR, XOR, XNOR) that can be created within each of the 2-bit LUT logic cells.

Table 33: 2-bit LUT Standard Digital Functions

Function	MSB			LSB
AND-2	1	0	0	0
NAND-2	0	1	1	1
OR-2	1	1	1	0
NOR-2	0	0	0	1
XOR-2	0	1	1	0
XNOR-2	1	0	0	1

7.1.2 Initial Polarity Operations

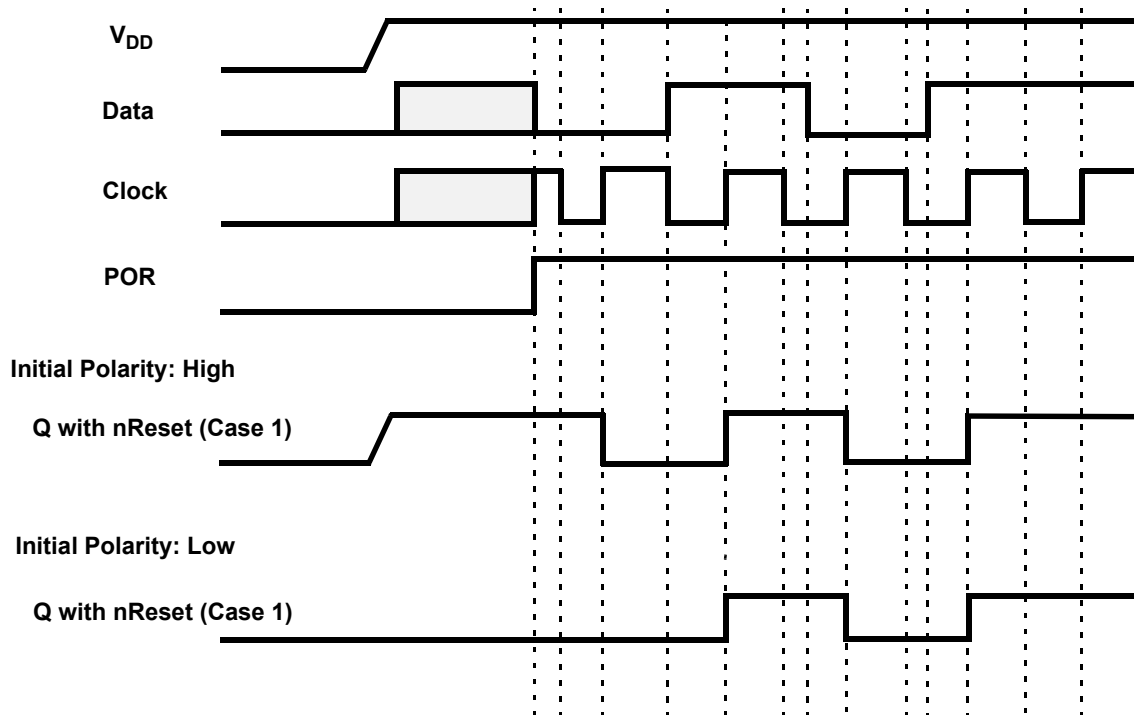

Figure 26: DFF Polarity Operations

7.2 2-BIT LUT OR PROGRAMMABLE PATTERN GENERATOR

The SLG46880/81 has one combination function macrocell that can serve as a logic or timing function. This macrocell can serve as a Look Up Table (LUT), or Programmable Pattern Generator (PGen).

When used to implement LUT functions, the 2-bit LUT takes in two input signals from the connection matrix and produces a single output, which goes back into the connection matrix. When used as a LUT to implement combinatorial logic functions, the outputs of the LUT can be configured to any user defined function, including the following standard digital logic devices (AND, NAND, OR, NOR, XOR, XNOR). The user can also define the combinatorial relationship between inputs and outputs to be any selectable function.

When operating as a Programmable Pattern Generator, the output of the macrocell with clock out a sequence of two to sixteen bits that are user selectable in their bit values, and user selectable in the number of bits (up to sixteen) that are output before the pattern repeats.

GreenPAK Programmable Mixed-Signal Matrix with Asynchronous State Machine and Dual Supply

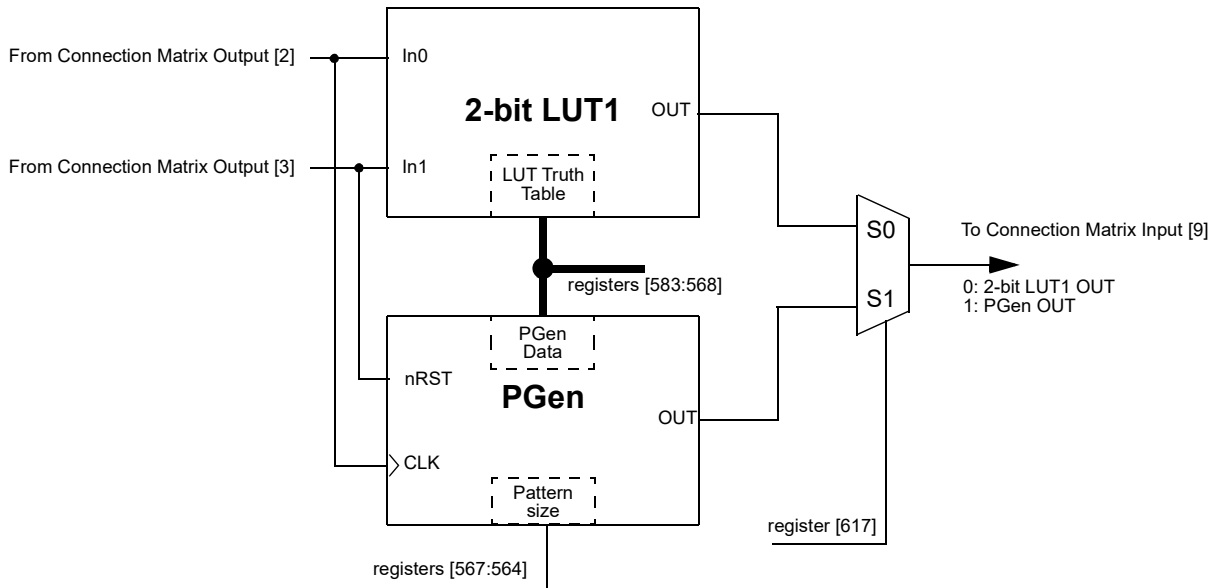

Figure 27: 2-bit LUT1 or PGen

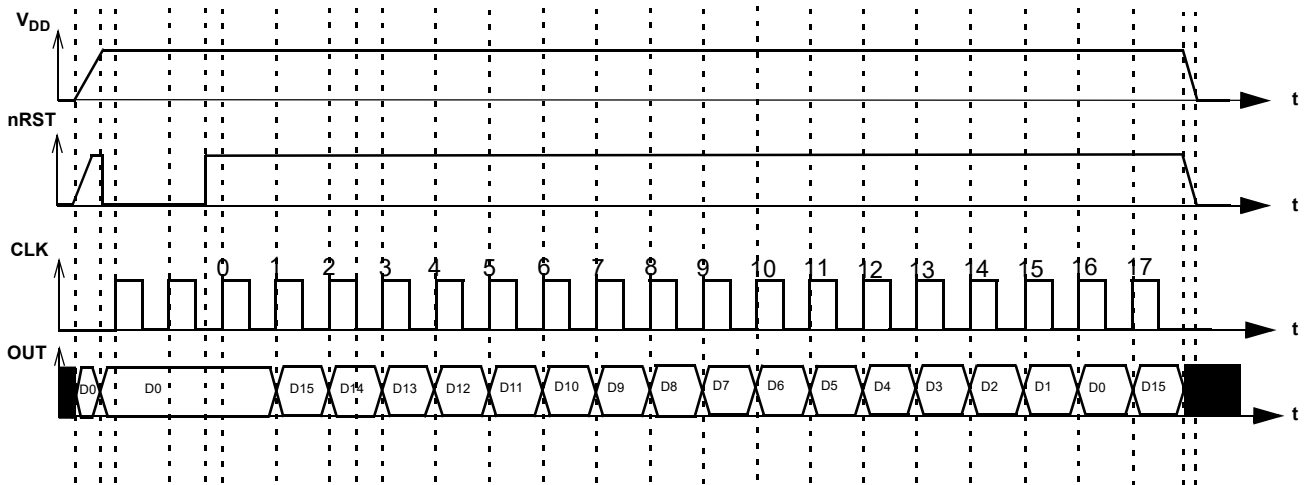

Figure 28: PGen Timing Diagram

GreenPAK Programmable Mixed-Signal Matrix with Asynchronous State Machine and Dual Supply

7.2.1 2-Bit LUT or PGen Macrocell Used as 2-Bit LUT

Table 34: 2-bit LUT1 Truth Table

IN1	IN0	OUT	
0	0	register [564]	LSB
0	1	register [565]	
1	0	register [566]	
1	1	register [567]	MSB

This macrocell, when programmed for a LUT function, uses a 4-bit register to define their output function:

2-Bit LUT1 is defined by registers [567:564]

Table 35 shows the register bits for the standard digital logic devices (AND, NAND, OR, NOR, XOR, XNOR) that can be created within each of the 2-bit LUT logic cells.

Table 35: 2-bit LUT Standard Digital Functions

Function	MSB			LSB
AND-2	1	0	0	0
NAND-2	0	1	1	1
OR-2	1	1	1	0
NOR-2	0	0	0	1
XOR-2	0	1	1	0
XNOR-2	1	0	0	1

7.3 3-BIT LUT OR D FLIP-FLOP WITH SET/RESET MACROCELLS

There are four macrocells that can serve as either 3-bit LUTs or as D Flip-Flops with Set/Reset inputs. When used to implement LUT functions, the 3-bit LUTs each take in three input signals from the connection matrix and produce a single output, which goes back into the connection matrix. When used to implement D Flip-Flop function, the three input signals from the connection matrix go to the data (D) and clock (CLK), and Reset/Set (nRST/nSET) inputs for the Flip-Flop, with the output going back to the connection matrix.

DFF1 operation will flow the functional description below:

- if register [619] = 0, and the CLK is rising edge triggered, then Q = D, otherwise Q will not change
- if register [619] = 1, then data from D is written into the DFF by the rising edge on CLK and output to Q by the falling edge on CLK

GreenPAK Programmable Mixed-Signal Matrix with Asynchronous State Machine and Dual Supply

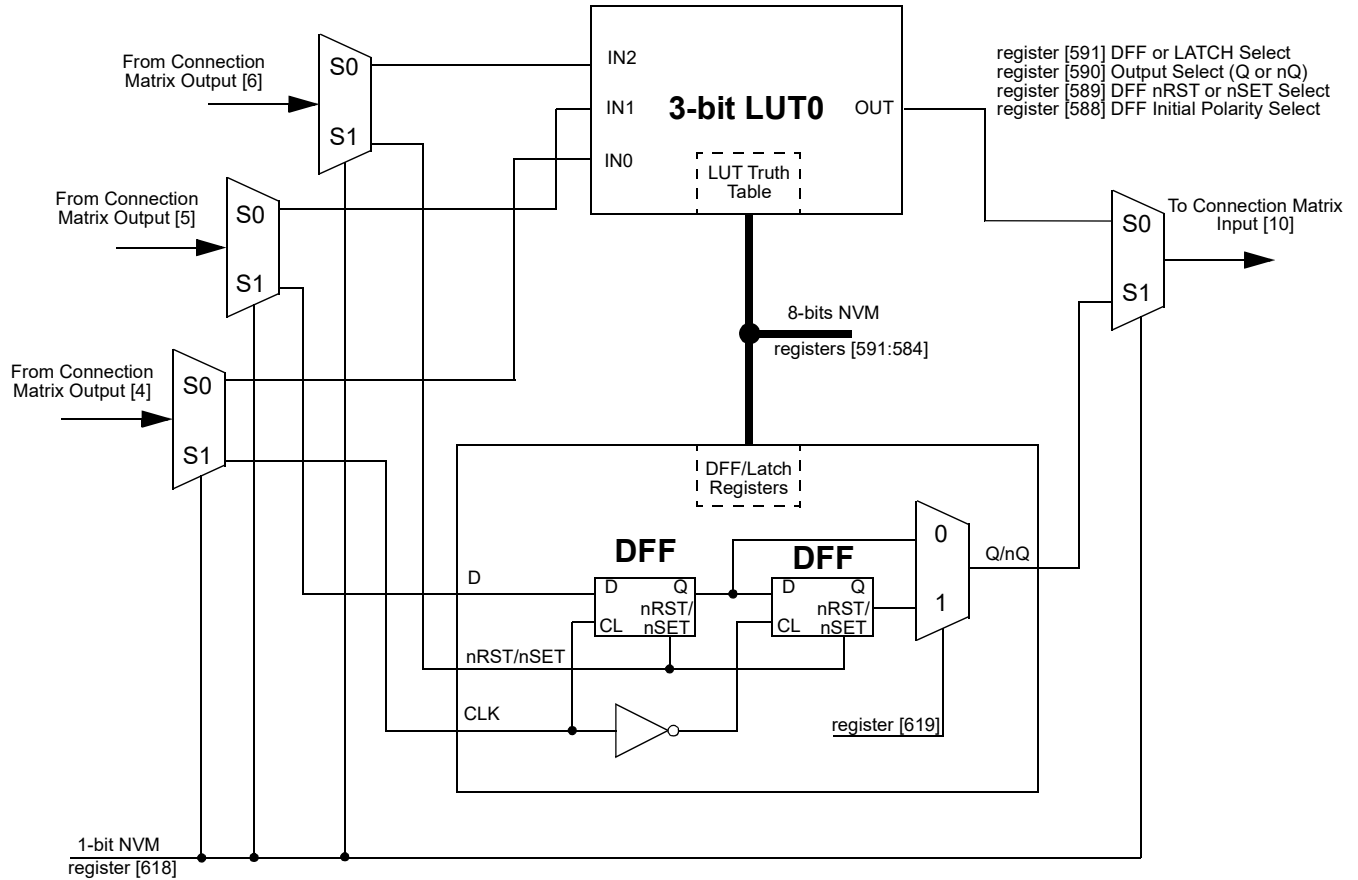

Figure 29: 3-bit LUT0 or DFF1

GreenPAK Programmable Mixed-Signal Matrix with Asynchronous State Machine and Dual Supply

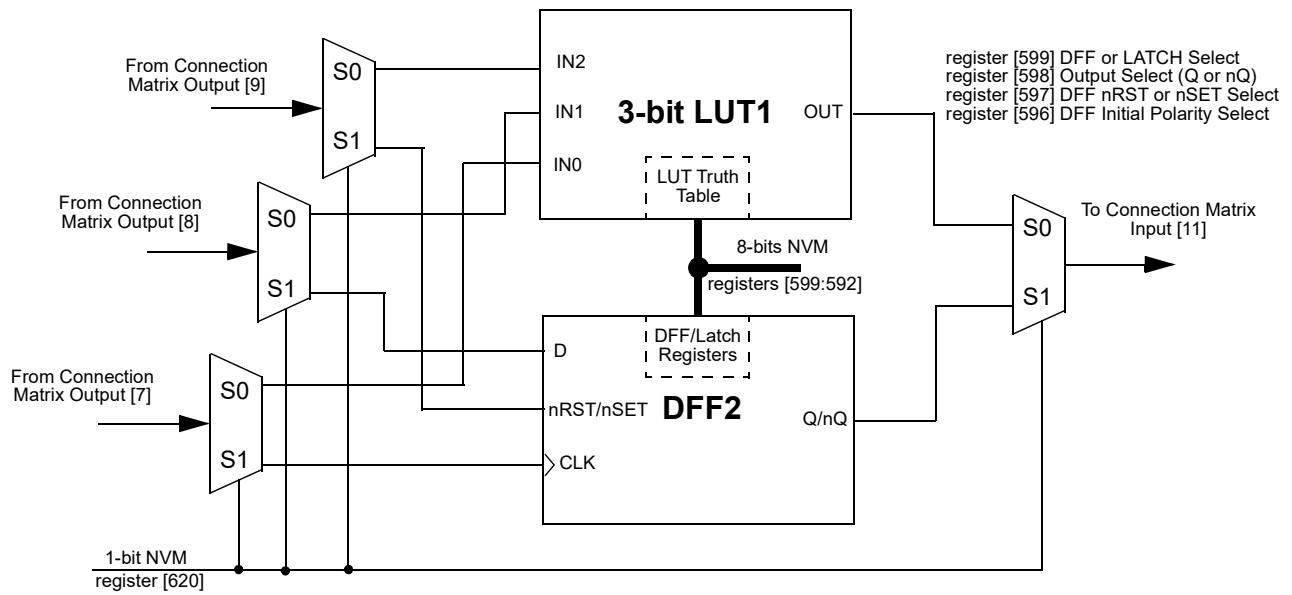

Figure 30: 3-bit LUT1 or DFF2

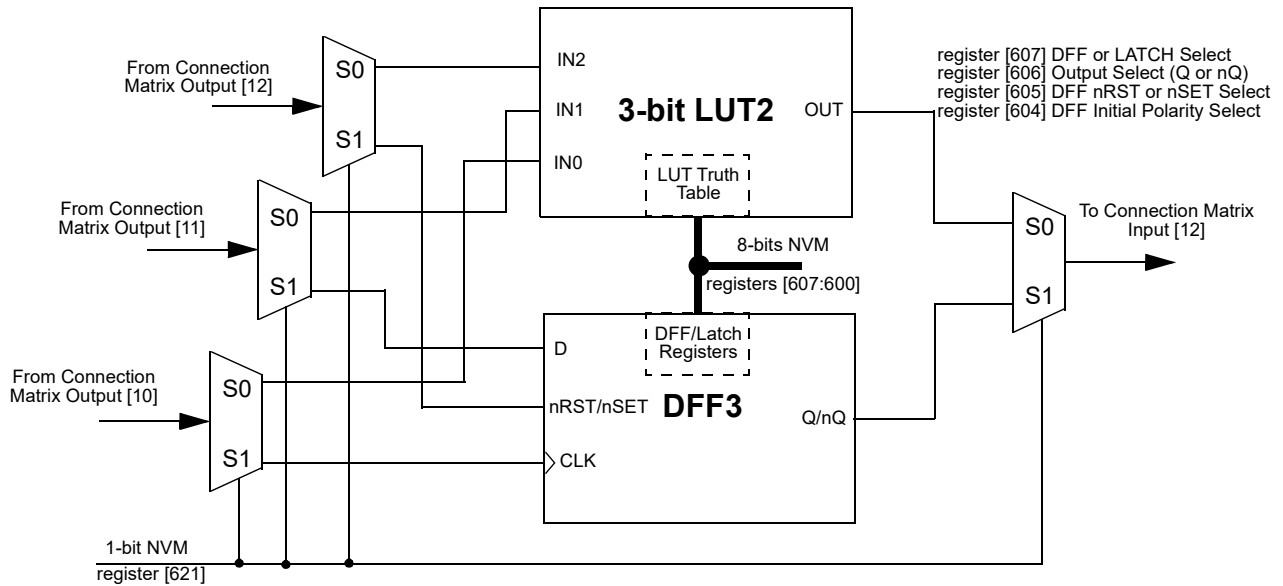

Figure 31: 3-bit LUT2 or DFF3

GreenPAK Programmable Mixed-Signal Matrix with Asynchronous State Machine and Dual Supply

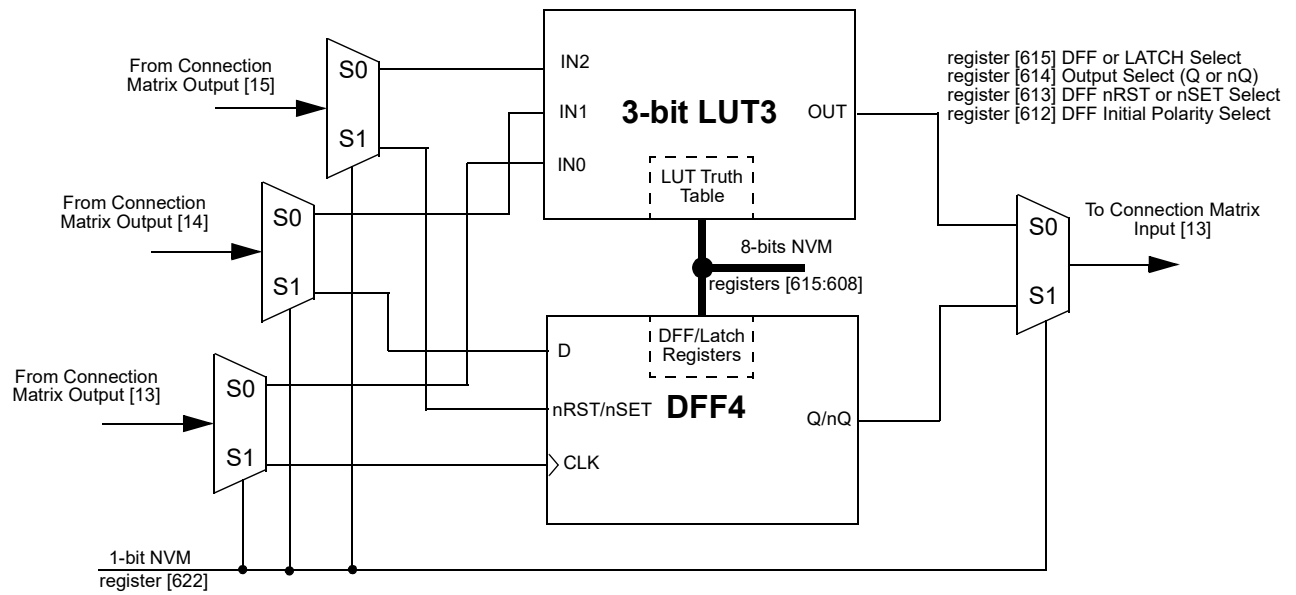

Figure 32: 3-bit LUT3 or DFF4

GreenPAK Programmable Mixed-Signal Matrix with Asynchronous State Machine and Dual Supply

7.3.1 3-Bit LUT or D Flip-Flop Macrocells Used as 3-Bit LUTs

Table 36: 3-bit LUT0 Truth Table

IN2	IN1	IN0	OUT	
0	0	0	register [584]	LSB
0	0	1	register [585]	
0	1	0	register [586]	
0	1	1	register [587]	
1	0	0	register [588]	
1	0	1	register [589]	
1	1	0	register [590]	
1	1	1	register [591]	MSB

Table 37: 3-bit LUT1 Truth Table

IN2	IN1	IN0	OUT	
0	0	0	register [592]	LSB
0	0	1	register [593]	
0	1	0	register [594]	
0	1	1	register [595]	
1	0	0	register [596]	
1	0	1	register [597]	
1	1	0	register [598]	
1	1	1	register [599]	MSB

Table 38: 3-bit LUT2 Truth Table

IN2	IN1	IN0	OUT	
0	0	0	register [600]	LSB
0	0	1	register [601]	
0	1	0	register [602]	
0	1	1	register [603]	
1	0	0	register [604]	
1	0	1	register [605]	
1	1	0	register [606]	
1	1	1	register [607]	MSB

Table 39: 3-bit LUT3 Truth Table

IN2	IN1	IN0	OUT	
0	0	0	register [608]	LSB
0	0	1	register [609]	
0	1	0	register [610]	
0	1	1	register [611]	
1	0	0	register [612]	
1	0	1	register [613]	
1	1	0	register [614]	
1	1	1	register [615]	MSB

Each macrocell, when programmed for a LUT function, uses a 8-bit register to define their output function:

3-Bit LUT0 is defined by registers [591:584]

3-Bit LUT1 is defined by registers [599:592]

3-Bit LUT2 is defined by registers [607:600]

3-Bit LUT3 is defined by registers [615:608]

Table 40 shows the register bits for the standard digital logic devices (AND, NAND, OR, NOR, XOR, XNOR) that can be created within each of the four 3-bit LUT logic cells.

Table 40: 3-bit LUT Standard Digital Functions

Function	MSB							LSB
AND-3	1	0	0	0	0	0	0	0
NAND-3	0	1	1	1	1	1	1	1
OR-3	1	1	1	1	1	1	1	0
NOR-3	0	0	0	0	0	0	0	1
XOR-3	1	0	0	1	0	1	1	0
XNOR-3	0	1	1	0	1	0	0	1

7.3.2 Initial Polarity Operations

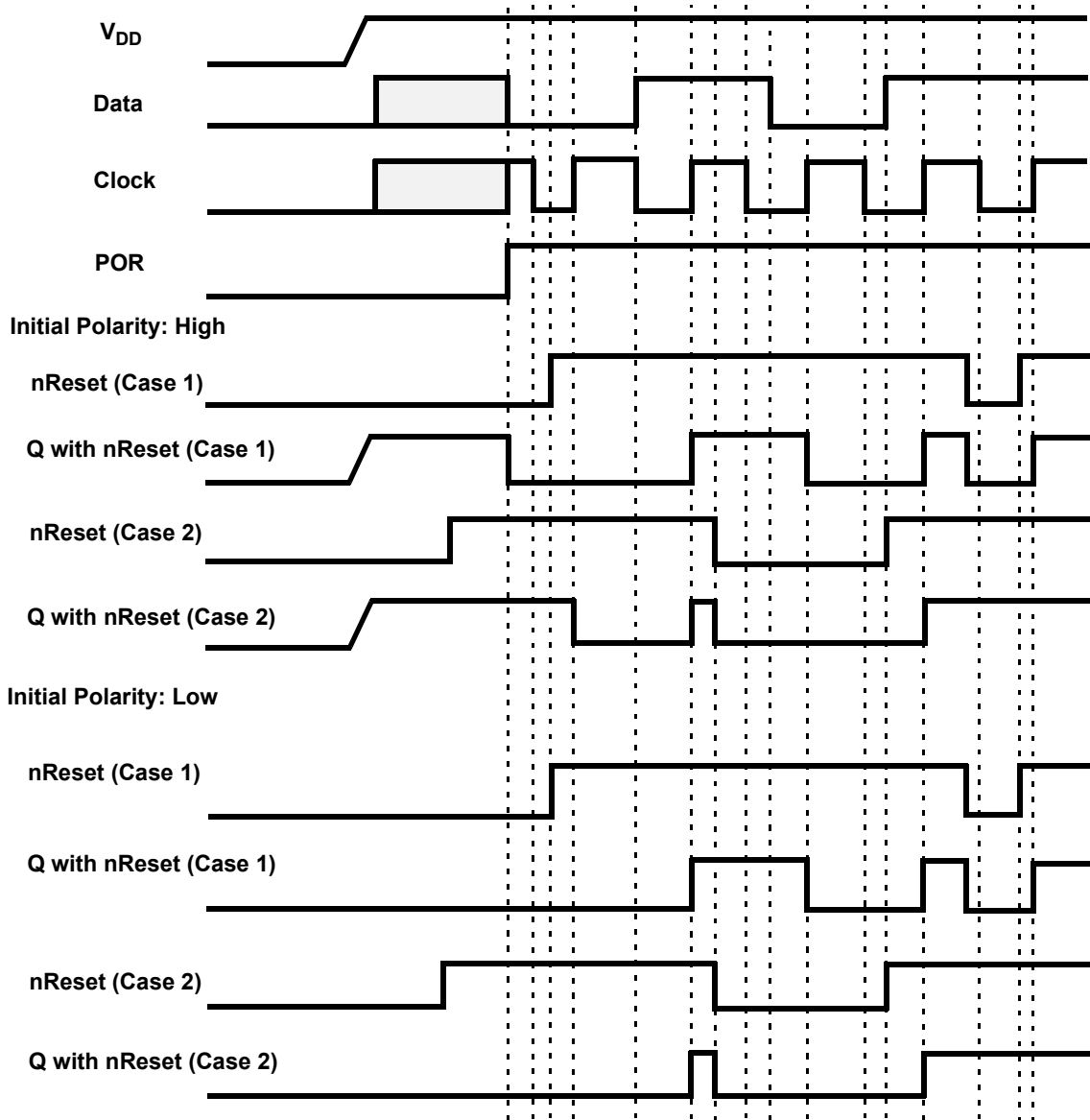

Figure 33: DFF Polarity Operations with nReset

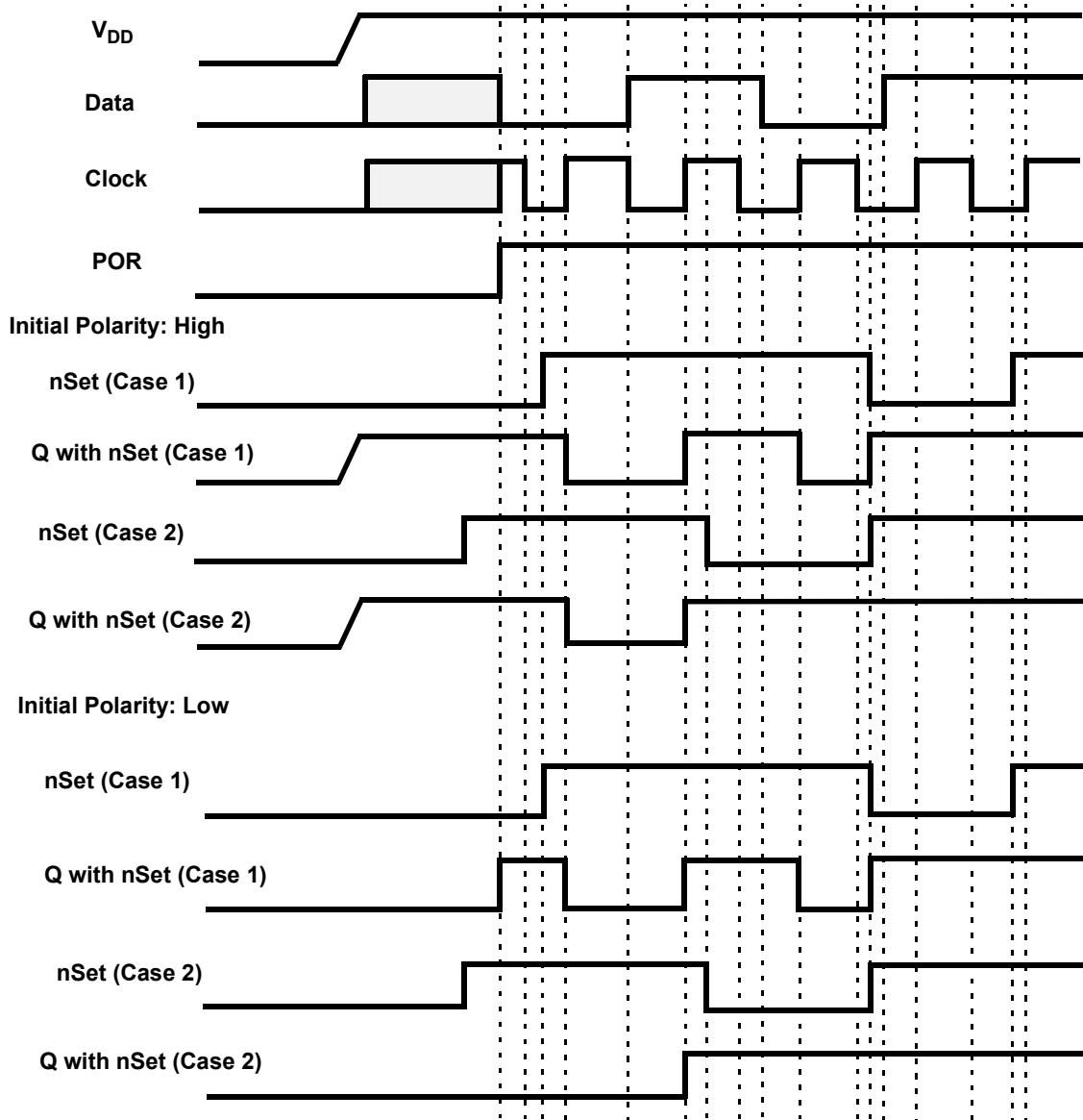

Figure 34: DFF Polarity Operations with nSet

7.4 3-BIT LUT OR PIPE DELAY/RIPPLE COUNTER MACROCELL

There is one macrocell that can serve as either a 3-bit LUT or as a Pipe Delay/Ripple Counter.

When used to implement LUT functions, the 3-bit LUT takes in three input signals from the connection matrix and produces a single output, which goes back into the connection matrix.

When used as a Pipe Delay, there are three inputs signals from the matrix, Input (IN), Clock (CLK), and Reset (nRST). The Pipe Delay cell is built from 16 D Flip-Flop logic cells that provide the three delay options, two of which are user selectable. The DFF cells are tied in series where the output (Q) of each delay cell goes to the next DFF cell input (IN). Both of the two outputs (OUT0 and OUT1) provide user selectable options for 1 to 16 stages of delay. There are delay output points for each set of the OUT0 and OUT1 outputs to a 4-input mux that is controlled by registers [547:544] for OUT0 and registers [551:548] for OUT1. The 4-input mux is used to control the selection of the amount of delay.

GreenPAK Programmable Mixed-Signal Matrix with Asynchronous State Machine and Dual Supply

The overall time of the delay is based on the clock used in the SLG46880/81 design. Each DFF cell has a time delay of the inverse of the clock time (either external clock or the Oscillator within the SLG46880/81). The sum of the number of DFF cells used will be the total time delay of the Pipe Delay logic cell. OUT1 Output can be inverted (as selected by register [552]).

In the Ripple Counter mode there are 3 options for setting, which use 7 bits. There are 3 bits to set **nSET value (SV)** in range from 0 to 7. It is a value, which will be set into the Ripple Counter outputs when nSET input goes LOW. **End value (EV)** will use 3 bits for setting outputs code, which will be last code in the cycle. After reaching the EV, the Ripple Counter goes to the first code by the rising edge on CLK input. The **Functionality mode** option uses 1 bit. This setting defines how exactly Ripple Counter will operate.

The user can select one of the functionality modes by register: RANGE or FULL. If the RANGE option is selected, the count starts from SV. If UP input is LOW the count goes down: $SV \rightarrow EV \rightarrow EV-1$ to $SV+1 \rightarrow SV$, and others (if SV is smaller than EV), or $SV \rightarrow SV-1$ to $EV+1 \rightarrow EV \rightarrow SV$ (if SV is bigger than EV). If UP input is HIGH, count starts from SV up to EV, and others.

In the FULL range configuration the Ripple Counter functions as follows. If UP input is LOW, the count starts from SV and goes down to 0. Then current counter value jumps to EV and goes down to 0, and others.

If UP input is HIGH, count goes up starting from SV. Then current counter value jumps to 0 and counts up to EV, and others. See Ripple Counter functionality example in [Figure 36](#).

Every step is executed by the rising edge on CLK input.

GreenPAK Programmable Mixed-Signal Matrix with Asynchronous State Machine and Dual Supply

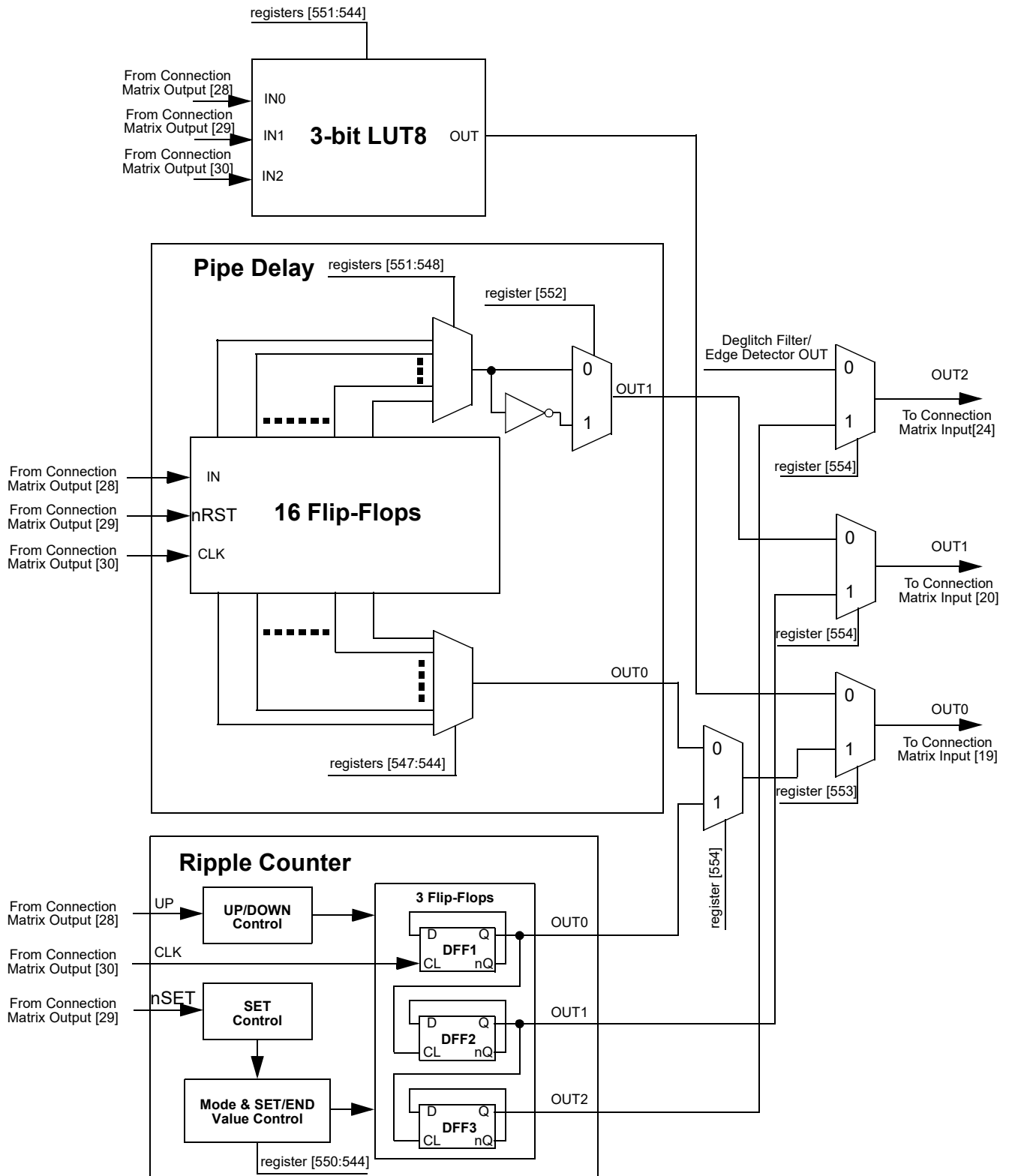

Figure 35: 3-bit LUT8/Pipe Delay/Ripple Counter

GreenPAK Programmable Mixed-Signal Matrix with Asynchronous State Machine and Dual Supply

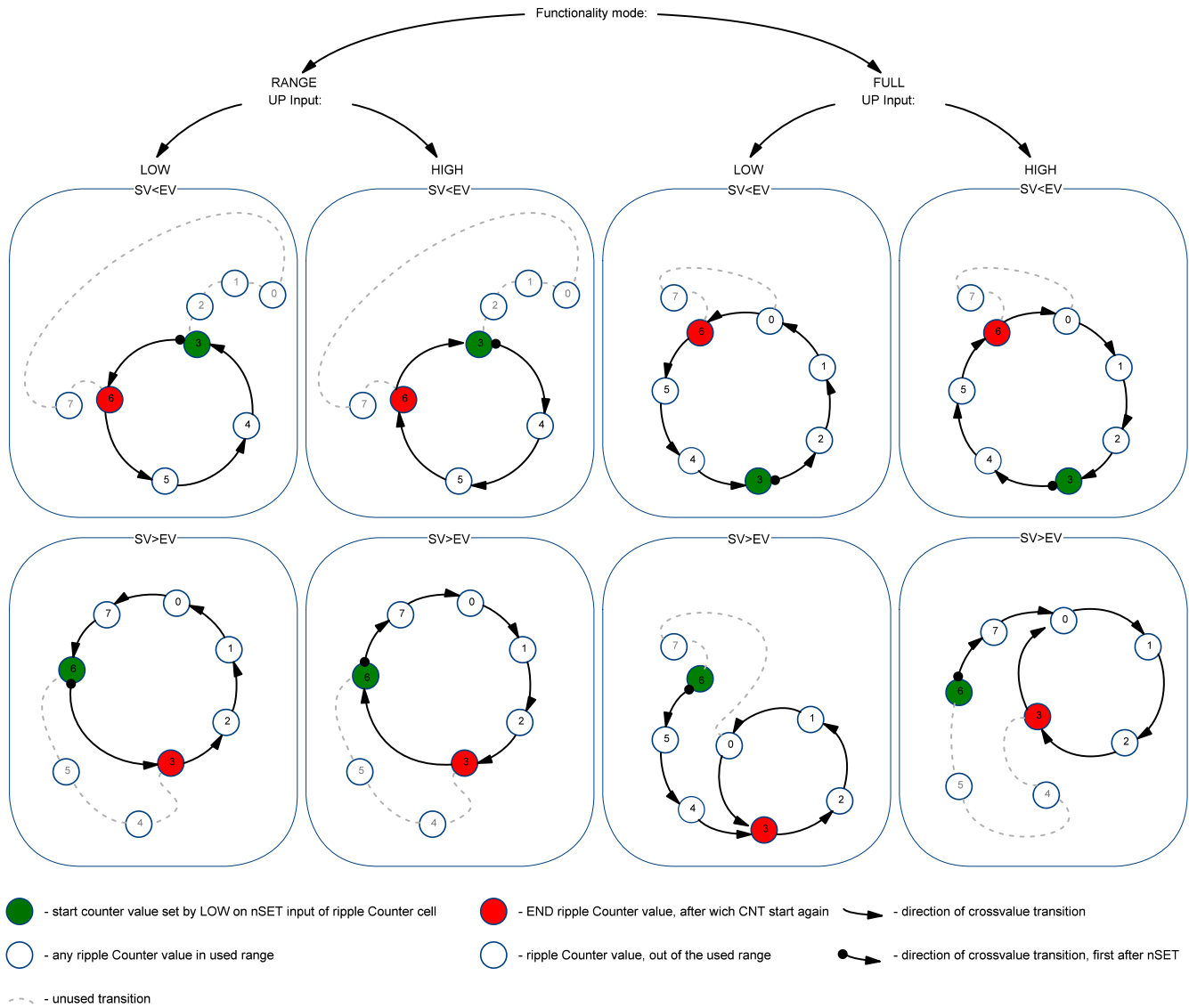

Figure 36: Example: Ripple Counter Functionality

7.4.1 3-Bit LUT or Pipe Delay Macrocells Used as 3-Bit LUT

Table 41: 3-bit LUT8 Truth Table

IN2	IN1	IN0	OUT
0	0	0	register [544]
0	0	1	register [545]
0	1	0	register [546]
0	1	1	register [547]
1	0	0	register [548]
1	0	1	register [549]
1	1	0	register [550]
1	1	1	register [551]

GreenPAK Programmable Mixed-Signal Matrix with Asynchronous State Machine and Dual Supply

Each macrocell, when programmed for a LUT function, uses a 8-bit register to define their output function:

3-Bit LUT8 is defined by registers [551:544]

7.5 3-BIT LUT OR 8-BIT COUNTER/DELAY MACROCELLS

There are four macrocells that can serve as either 3-bit LUTs or as Counter/Delays. When used to implement LUT function, the 3-bit LUT takes in three input signals from the connection matrix and produces a single output, which goes back into the connection matrix. When used to implement 8-Bit Counter/Delay function, two of the three input signals from the connection matrix go to the external clock (EXT_CLK) and reset (DLY_IN/CNT Reset) inputs for the Counter/Delay, with the output going back to the connection matrix.

Counter/Delay macrocell has an initial value, which defines its initial value after GPAK is powered up. It is possible to select initial Low or initial High, as well as initial value defined by a Delay In signal.

For example, in case initial LOW option is used, the rising edge delay will start operation.

These macrocells can also operate in a frequency detection mode.

Delay time and Output Period can be calculated using the following formulas:

- Delay time: $[(\text{Counter data} + 2)/\text{CLK input frequency} - \text{Offset (Note)}]$
- Output Period: $[(\text{Counter data} + 1)/\text{CLK input frequency} - \text{Offset (Note)}]$

One Shot pulse width can be calculated using formula:

- Pulse width = $[(\text{Counter Data} + 2)/\text{CLK input frequency} - \text{Offset (Note)}]$

Note: Offset is the asynchronous time offset between the input signal and the first clock pulse.

Three of the four macrocells can have their active count value read via I²C (CNT0, CNT2, and CNT4). See Section 19.6.1 for further details.

GreenPAK Programmable Mixed-Signal Matrix with Asynchronous State Machine and Dual Supply

7.5.1 3-Bit LUT or 8-Bit CNT/DLY Block Diagrams

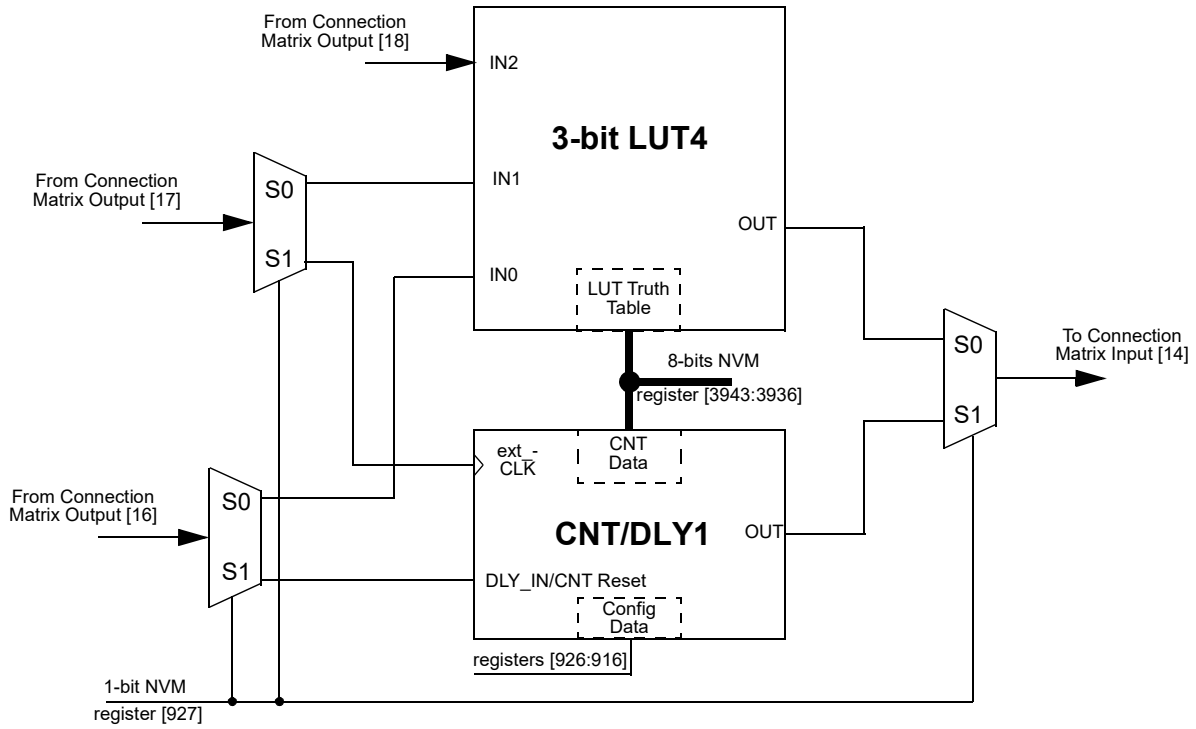

Figure 37: 3-bit LUT4 or CNT/DLY1

GreenPAK Programmable Mixed-Signal Matrix with Asynchronous State Machine and Dual Supply

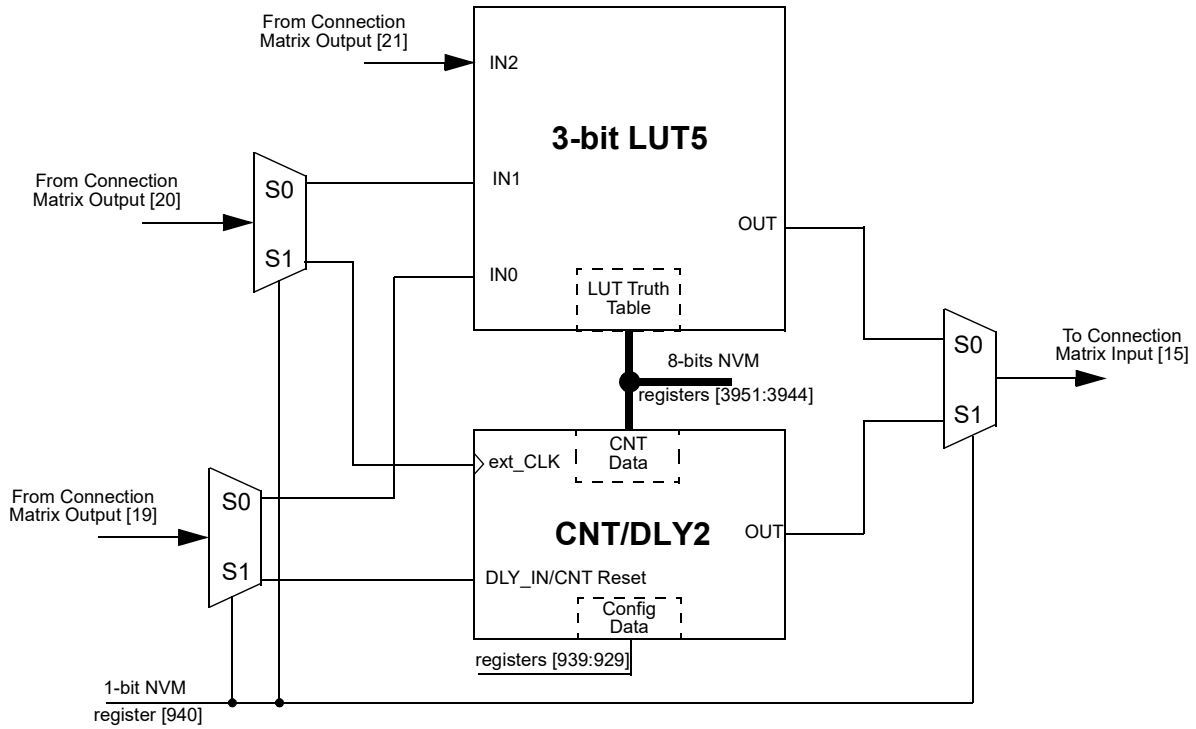

Figure 38: 3-bit LUT5 or CNT/DLY2

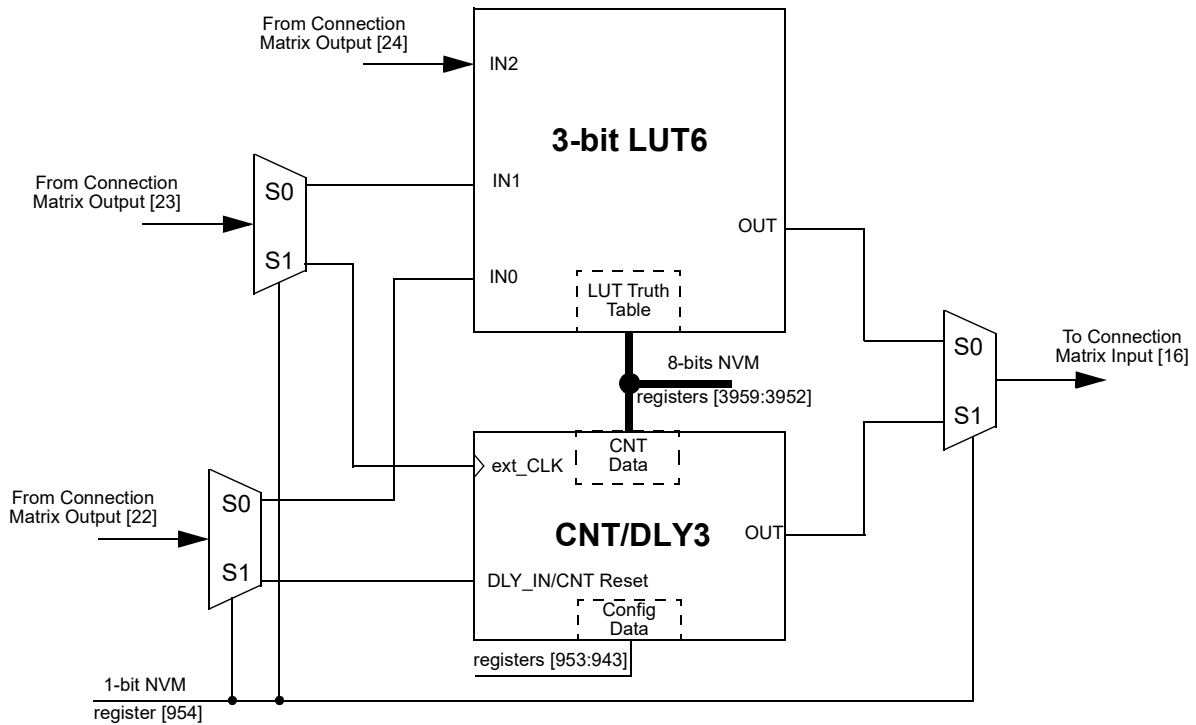

Figure 39: 3-bit LUT6 or CNT/DLY3

GreenPAK Programmable Mixed-Signal Matrix with Asynchronous State Machine and Dual Supply

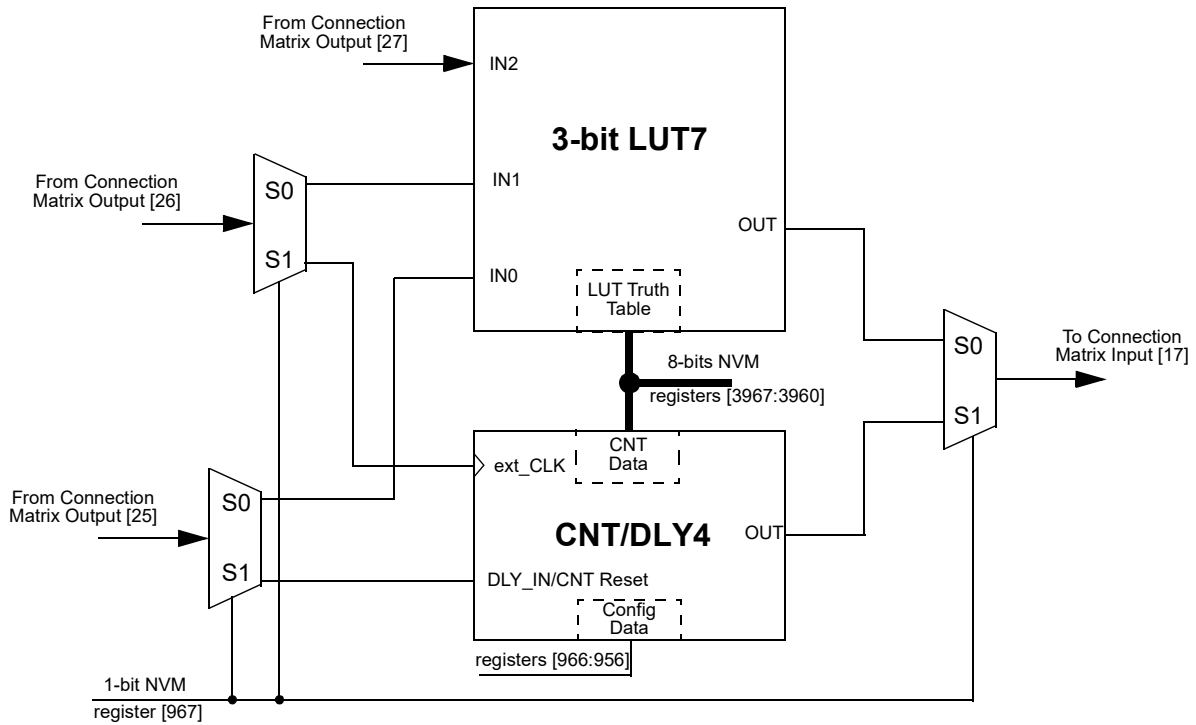

Figure 40: 3-bit LUT7 or CNT/DLY4

GreenPAK Programmable Mixed-Signal Matrix with Asynchronous State Machine and Dual Supply

7.5.2 3-Bit LUT or CNT/DLYs Used as 3-Bit LUTs

Table 42: 3-bit LUT4 Truth Table

IN2	IN1	IN0	OUT	
0	0	0	register [3936]	LSB
0	0	1	register [3937]	
0	1	0	register [3938]	
0	1	1	register [3939]	
1	0	0	register [3940]	
1	0	1	register [3941]	
1	1	0	register [3942]	
1	1	1	register [3943]	MSB

Table 43: 3-bit LUT5 Truth Table

IN2	IN1	IN0	OUT	
0	0	0	register [3944]	LSB
0	0	1	register [3945]	
0	1	0	register [3946]	
0	1	1	register [3947]	
1	0	0	register [3948]	
1	0	1	register [3949]	
1	1	0	register [3950]	
1	1	1	register [3951]	MSB

Table 44: 3-bit LUT6 Truth Table

IN2	IN1	IN0	OUT	
0	0	0	register [3952]	LSB
0	0	1	register [3953]	
0	1	0	register [3954]	
0	1	1	register [3955]	
1	0	0	register [3956]	
1	0	1	register [3957]	
1	1	0	register [3958]	
1	1	1	register [3959]	MSB

Table 45: 3-bit LUT7 Truth Table

IN2	IN1	IN0	OUT	
0	0	0	register [3960]	LSB
0	0	1	register [3961]	
0	1	0	register [3962]	
0	1	1	register [3963]	
1	0	0	register [3964]	
1	0	1	register [3965]	
1	1	0	register [3966]	
1	1	1	register [3967]	MSB

Each macrocell, when programmed for a LUT function, uses a 8-bit register to define their output function:

3-Bit LUT4 is defined by registers [3943:3936]

3-Bit LUT5 is defined by registers [3951:3944]

3-Bit LUT6 is defined by registers [3959:3952]

3-Bit LUT7 is defined by registers [3967:3960]

GreenPAK Programmable Mixed-Signal Matrix with Asynchronous State Machine and Dual Supply

7.6 CNT/DLY/FSM TIMING DIAGRAMS

7.6.1 Delay Mode (Edge Select: Both, Counter Data: 3) CNT/DLY2 to CNT/DLY6

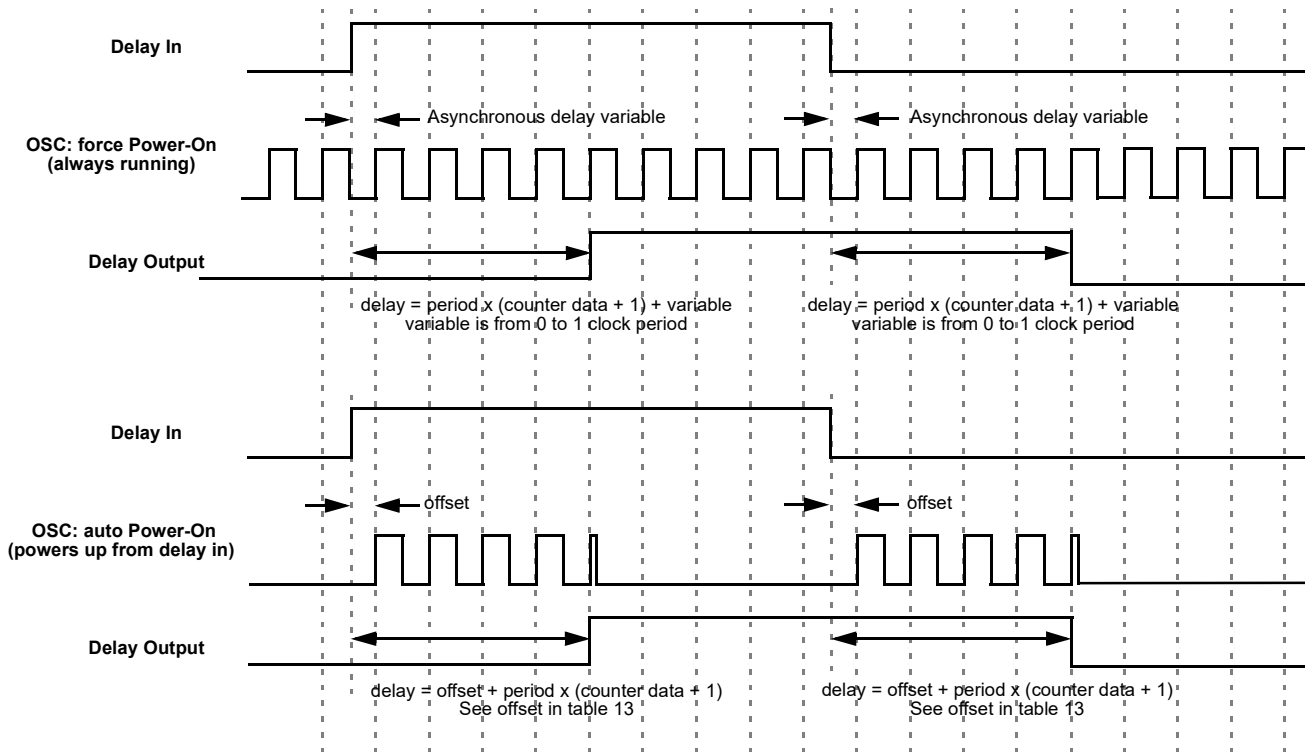

Figure 41: Delay Mode Timing Diagram

7.6.2 Count Mode (Count Data: 3), Counter Reset (Rising Edge Detect) CNT/DLY2 to CNT/DLY6

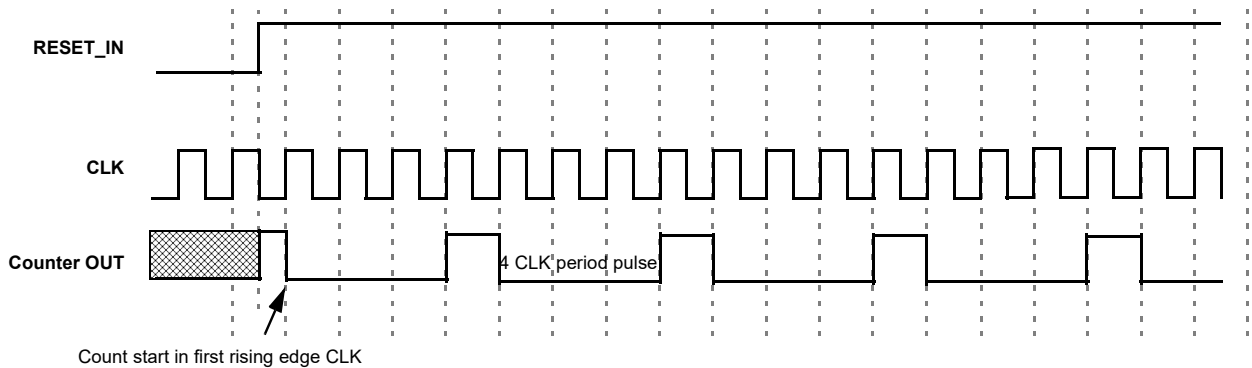

Figure 42: Counter Mode Timing Diagram without Two DFFs Synced Up

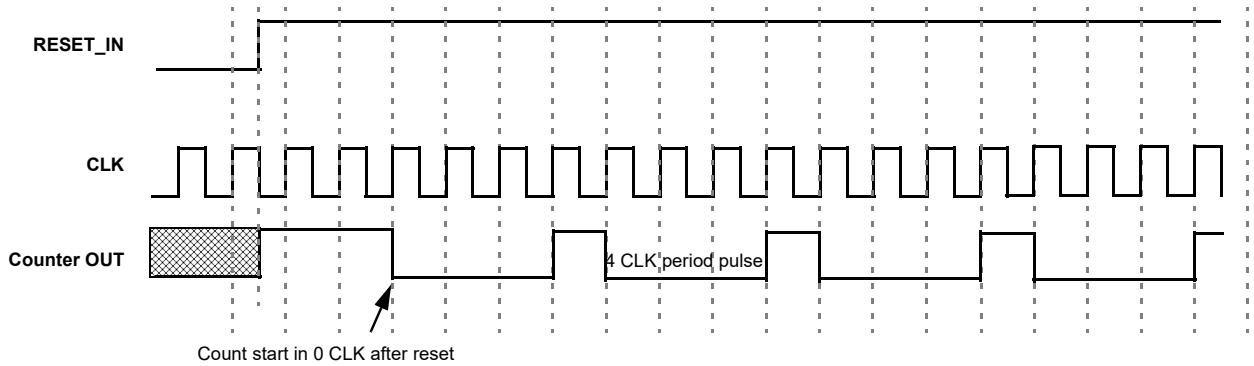

Figure 43: Counter Mode Timing Diagram with Two DFFs Synced Up

7.6.3 One-Shot Mode CNT/DLY0 to CNT/DLY6

This macrocell will generate a pulse whenever a selected edge is detected on its input. Register bits set the edge selection. The pulse width determines by counter data and clock selection properties. The output pulse polarity (non-inverted or inverted) is selected by register bit. Any incoming edges will be ignored during the pulse width generation. The following diagram shows one-shot function for non-inverted output.

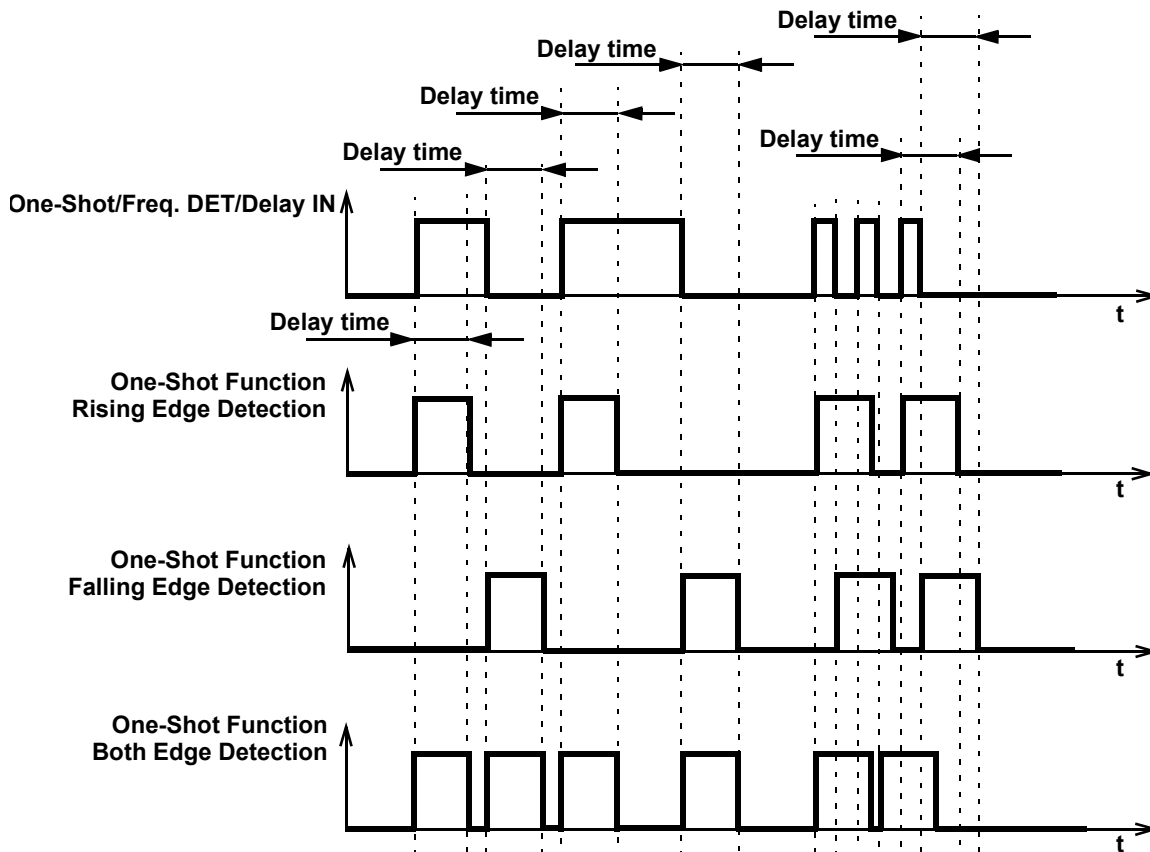

Figure 44: One-Shot Function Timing Diagram

GreenPAK Programmable Mixed-Signal Matrix with Asynchronous State Machine and Dual Supply

This macrocell generates a high level pulse with a set width (defined by counter data) when detecting the respective edge. It does not restart while pulse is high.

7.6.4 Frequency Detection Mode CNT/DLY0 to CNT/DLY6

Rising Edge: The output goes high if the time between two successive edges is less than the delay. The output goes low if the second rising edge has not come after the last rising edge in specified time.

Falling Edge: The output goes high if the time between two falling edges is less than the set time. The output goes low if the second falling edge has not come after the last falling edge in specified time.

Both Edge: The output goes high if the time between the rising and falling edges is less than the set time, which is equivalent to the length of the pulse. The output goes low if after the last rising/falling edge and specified time, the second edge has not come.

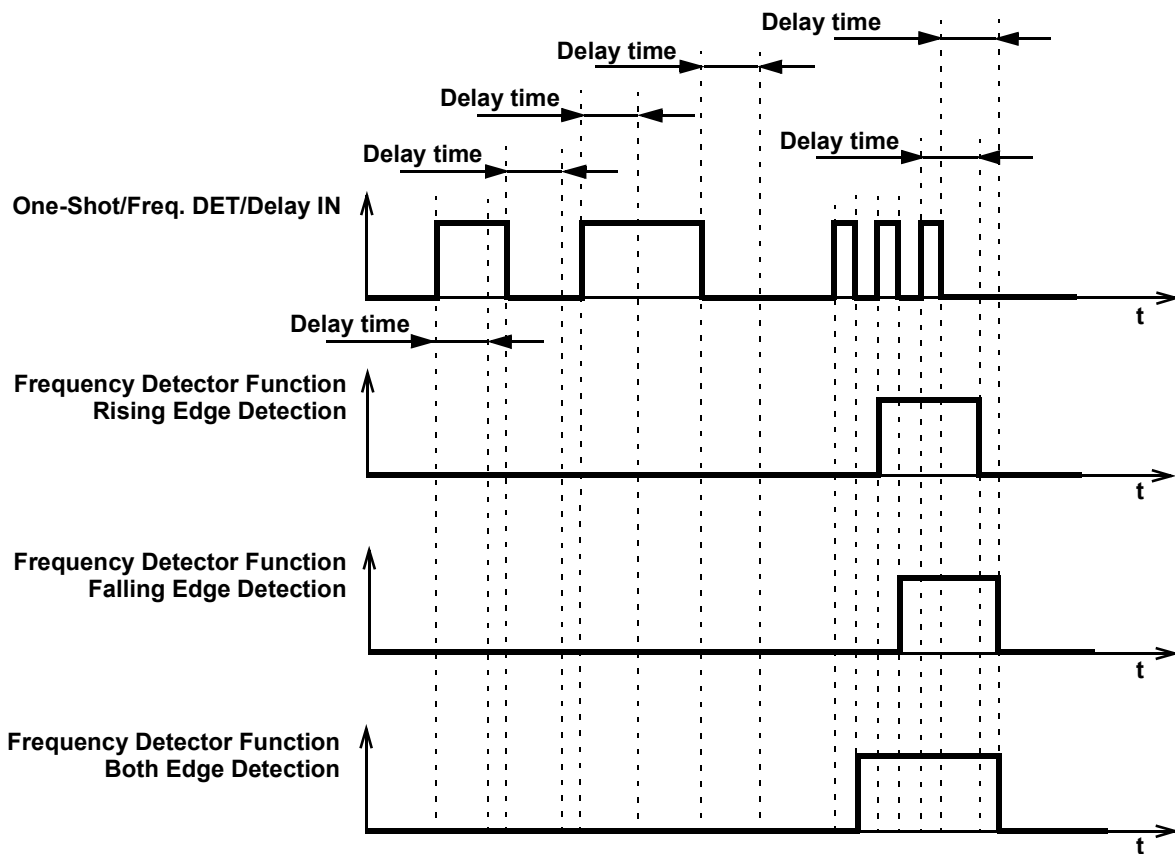

Figure 45: Frequency Detection Mode Timing Diagram

GreenPAK Programmable Mixed-Signal Matrix with Asynchronous State Machine and Dual Supply

7.6.5 Edge Detection Mode CNT/DLY2 to CNT/DLY6

The macrocell generates high level short pulse when detecting the respective edge. See [Table 14](#).

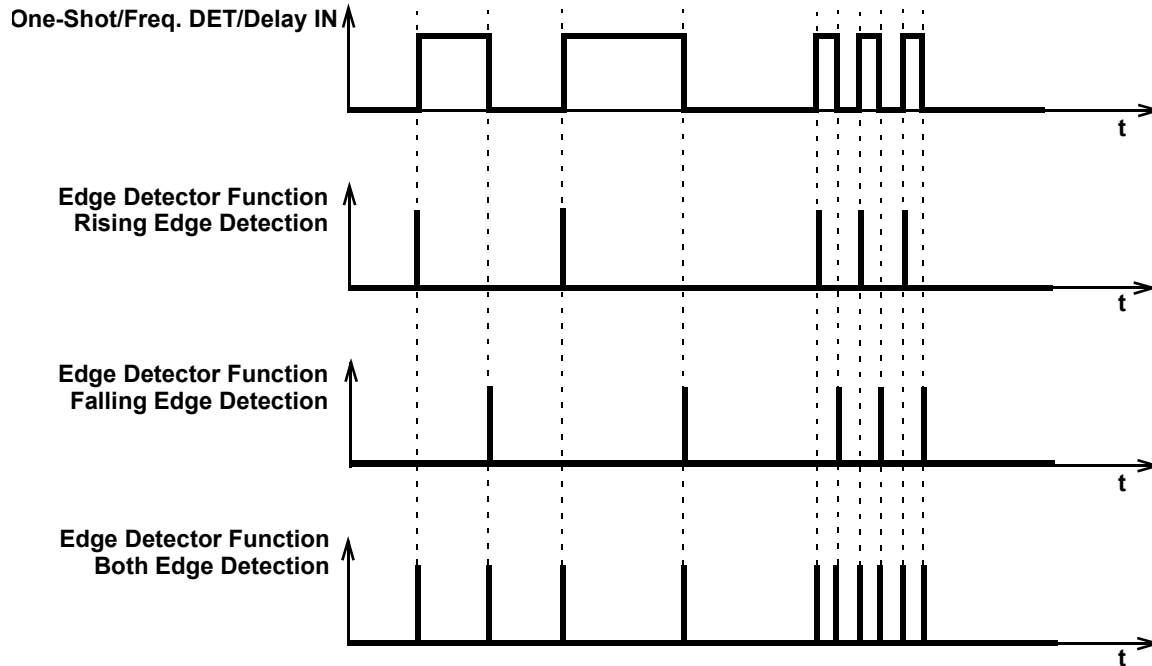

Figure 46: Edge Detection Mode Timing Diagram

GreenPAK Programmable Mixed-Signal Matrix with Asynchronous State Machine and Dual Supply

7.6.5.1 Delayed Edge Detection Mode

In Delayed Edge Detection Mode, High level short pulses are generated on the macrocell output after the configured delay time if the corresponding edge was detected on the input.

If the input signal is changed during the set delay time, the pulse will not be generated. See Figure 47.

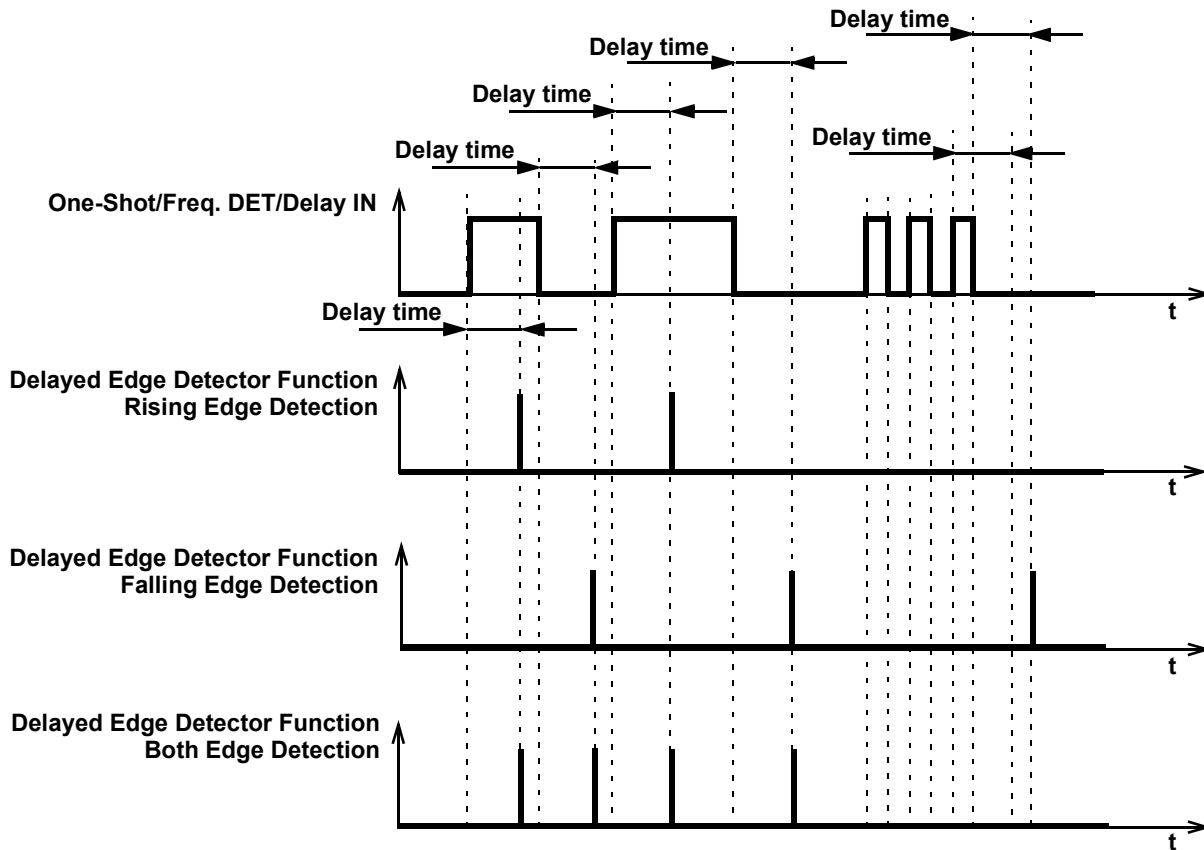

Figure 47: Delayed Edge Detection Mode Timing Diagram

GreenPAK Programmable Mixed-Signal Matrix with Asynchronous State Machine and Dual Supply

7.6.6 Delay Mode CNT/DLY0 to CNT/DLY6

The macrocell shifts the respective edge to a set time and restarts by appropriate edge. It works as a filter if the input signal is shorter than the delay time.

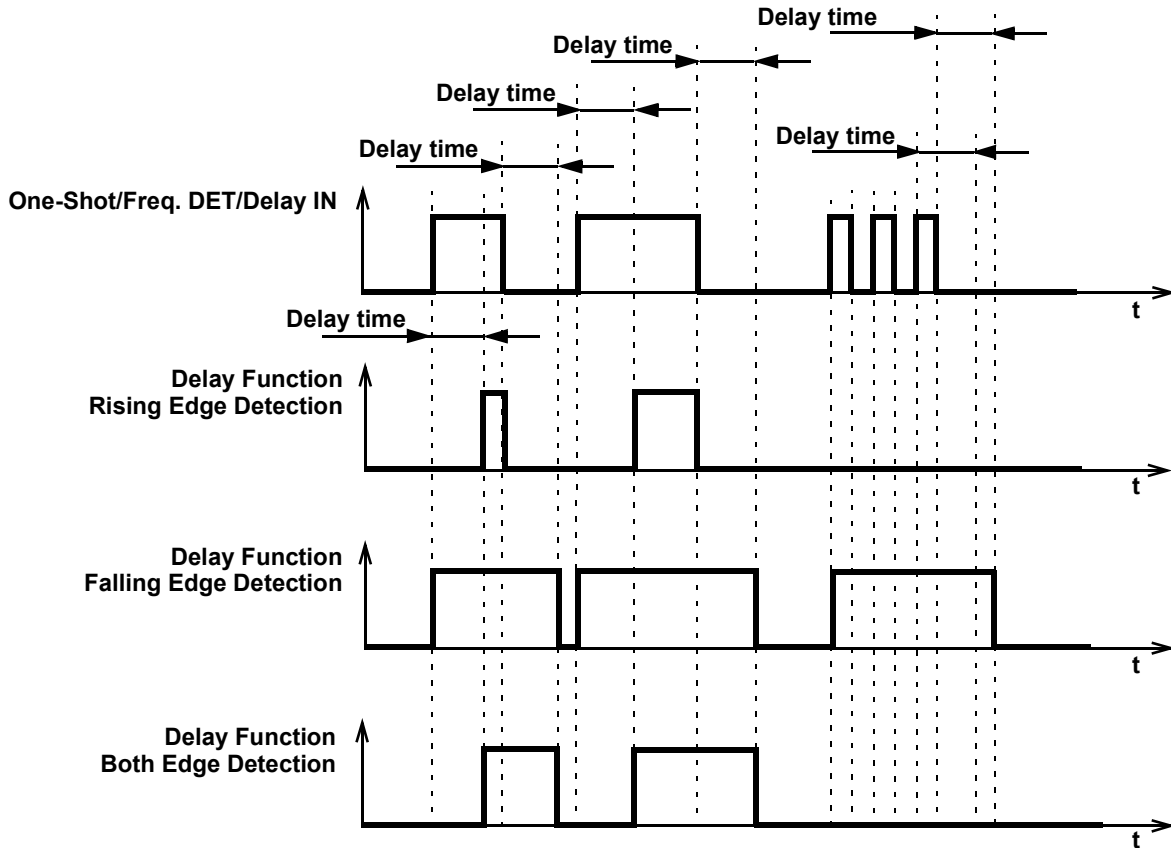
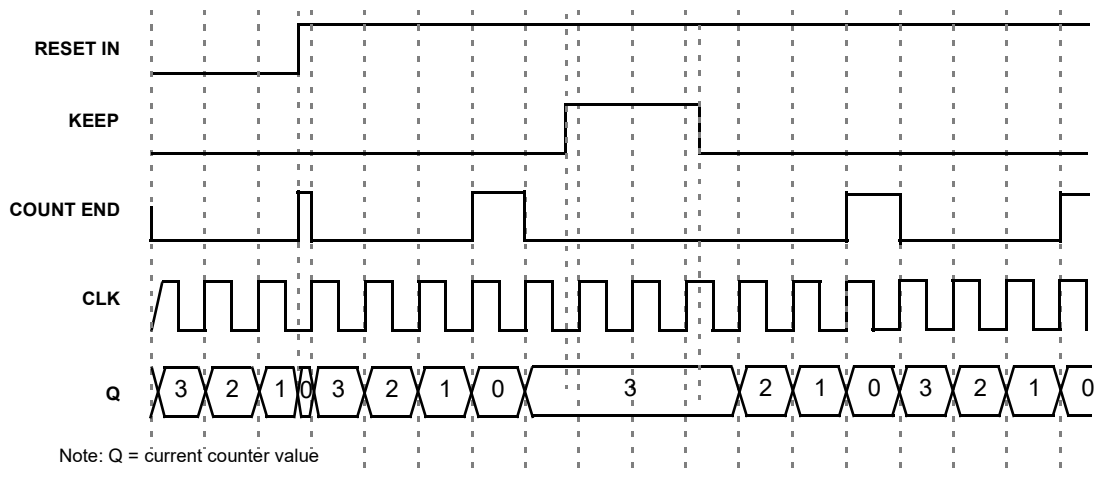

Figure 48: Delay Mode Timing Diagram

7.6.7 CNT/FSM Mode CNT/DLY0, CNT/DLY1



Note: Q = current counter value

Figure 49: CNT/FSM Timing Diagram (Reset Rising Edge Mode, Oscillator is Forced On, UP = 0) for Counter Data = 3

GreenPAK Programmable Mixed-Signal Matrix with Asynchronous State Machine and Dual Supply

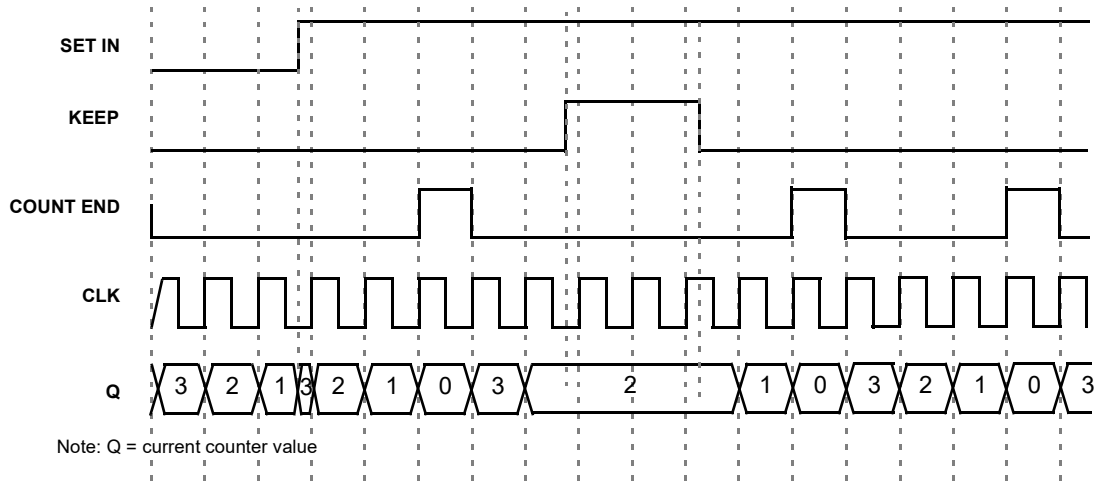

Figure 50: CNT/FSM Timing Diagram (Set Rising Edge Mode, Oscillator is Forced On, UP = 0) for Counter Data = 3

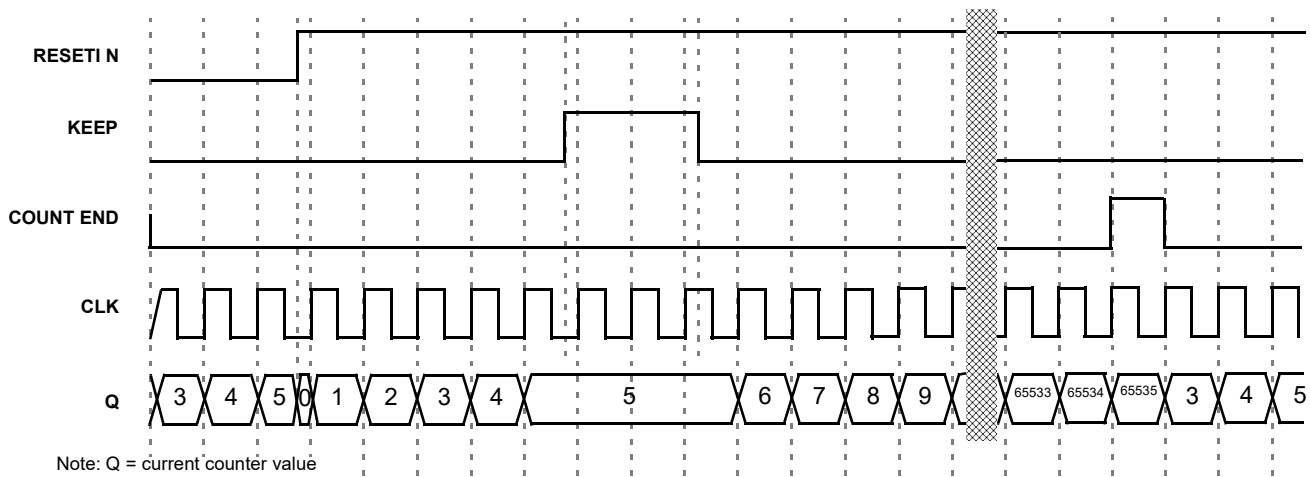

Figure 51: CNT/FSM Timing Diagram (Reset Rising Edge Mode, Oscillator is Forced On, UP = 1) for Counter Data = 3

GreenPAK Programmable Mixed-Signal Matrix with Asynchronous State Machine and Dual Supply

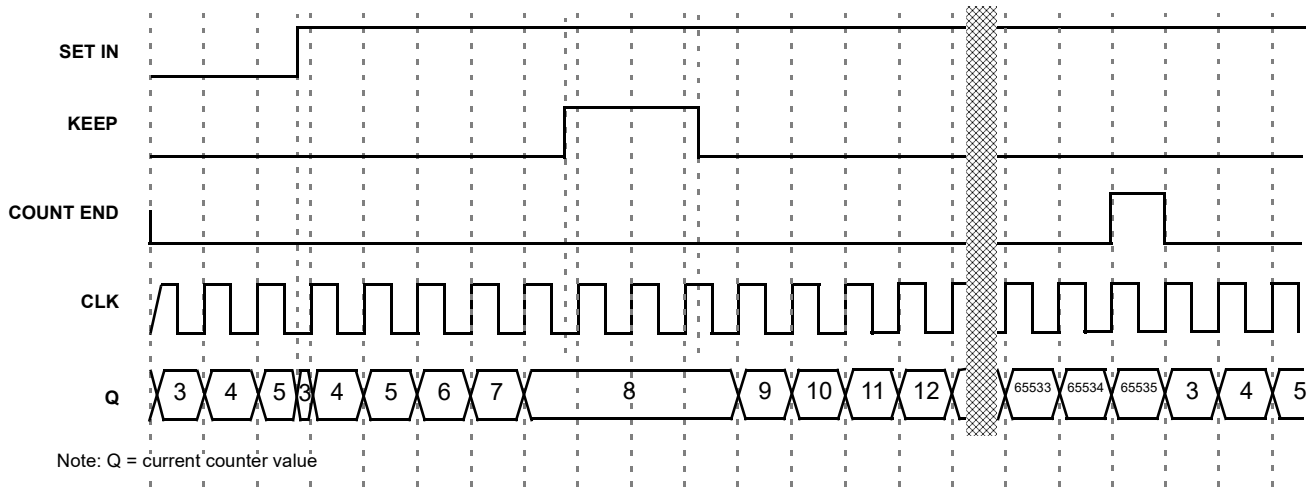

Figure 52: CNT/FSM Timing Diagram (Set Rising Edge Mode, Oscillator is Forced On, UP = 1) for Counter Data = 3

7.6.8 Difference in Counter Value for Counter, Delay, One-Shot, and Frequency Detect Modes

There is a difference in counter value for Counter and Delay/One-Shot/Frequency Detect modes. The counter value is shifted for two rising edges of the clock signal in Delay/One-Shot/Frequency Detect modes compared to Counter mode. See Figure 53.

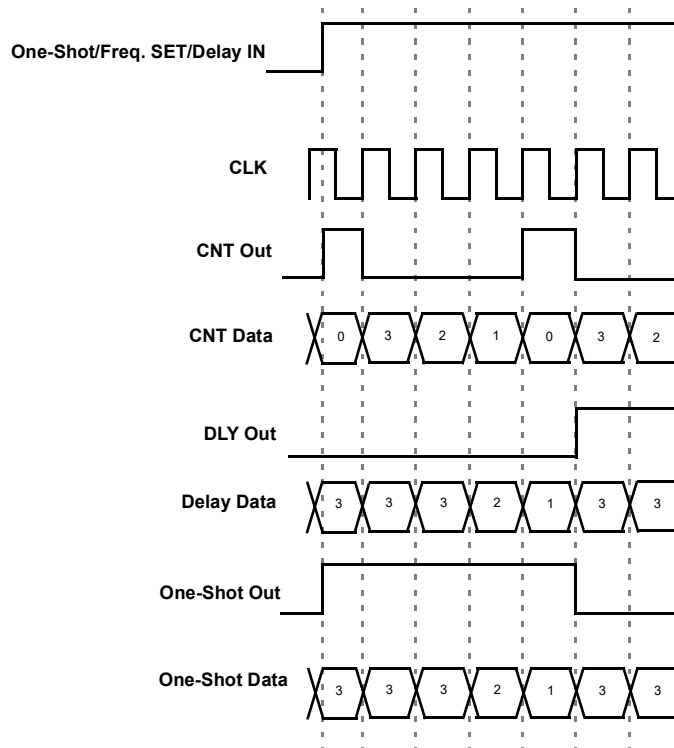

Figure 53: Counter Value, Counter Data = 3

GreenPAK Programmable Mixed-Signal Matrix with Asynchronous State Machine and Dual Supply

7.7 4-BIT LUT OR 16-BIT COUNTER/DELAY MACROCELL

There is one macrocell that can serve as either 4-bit LUT or as 16-bit Counter/Delay. When used to implement LUT function, the 4-bit LUT takes in four input signals from the Connection Matrix and produces a single output, which goes back into the Connection Matrix. When used to implement 16-Bit Counter/Delay function, two of the four input signals from the connection matrix go to the external clock (EXT_CLK) and reset (DLY_IN/CNT Reset) for the counter/delay, with the output going back to the connection matrix.

This macrocell has an optional Finite State Machine (FSM) function. There are two additional matrix inputs for Up and Keep to support FSM functionality.

This macrocell can also operate in a one-shot mode, which will generate an output pulse of user-defined width.

This macrocell can also operate in a frequency detection or edge detection mode.

This macrocell can have its active count value read via I²C. See Section 19.6.1 for further details.

7.7.1 4-Bit LUT or 16-Bit CNT/DLY Block Diagram

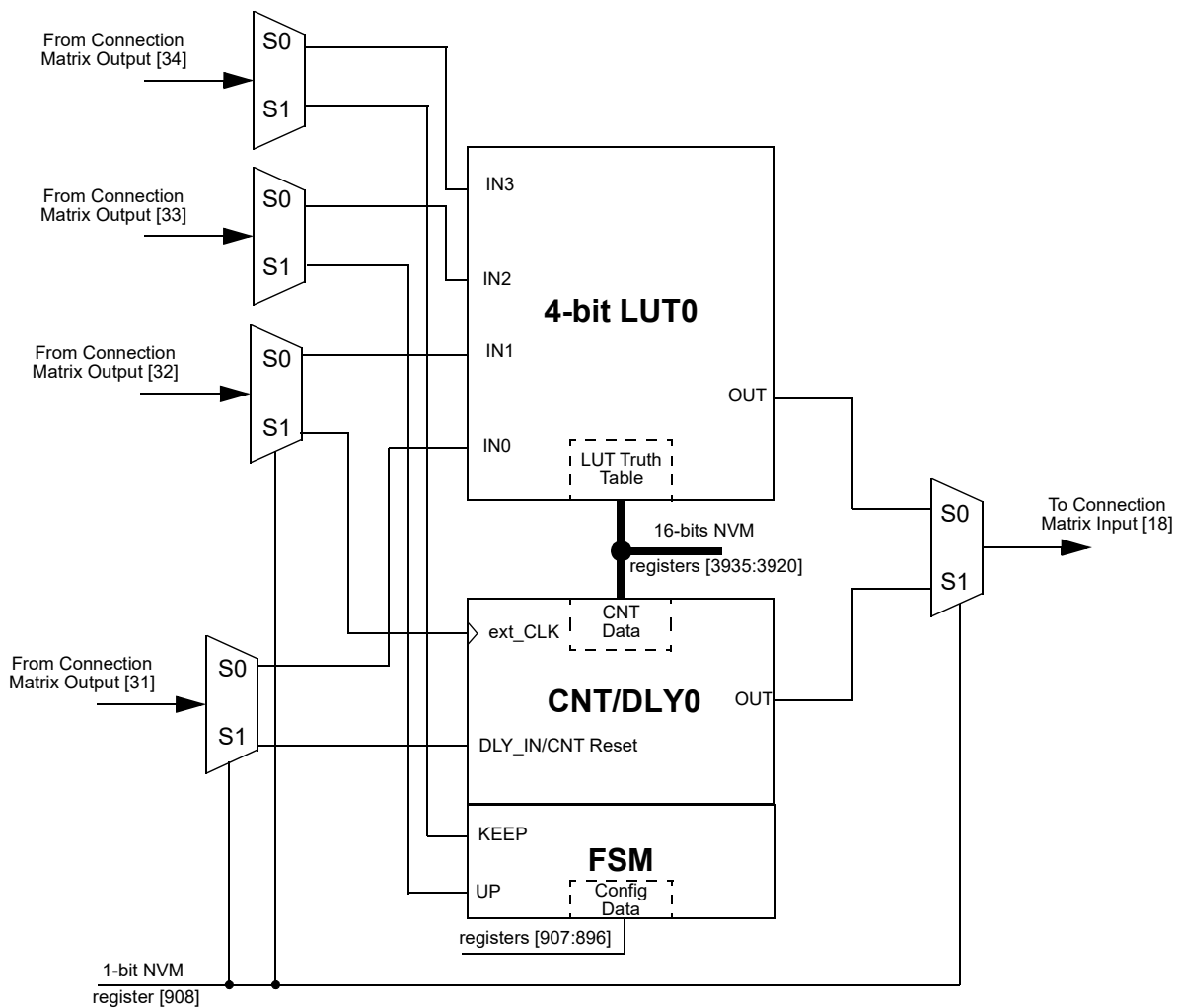

Figure 54: 4-bit LUT0 or CNT/DLY0

GreenPAK Programmable Mixed-Signal Matrix with Asynchronous State Machine and Dual Supply

7.7.2 4-Bit LUT or 16-Bit Counter/Delay Macrocells Used as 4-Bit LUTs

Table 46: 4-bit LUT0 Truth Table

IN3	IN2	IN1	IN0	OUT	
0	0	0	0	register [3920]	LSB
0	0	0	1	register [3921]	
0	0	1	0	register [3922]	
0	0	1	1	register [3923]	
0	1	0	0	register [3924]	
0	1	0	1	register [3925]	
0	1	1	0	register [3926]	
0	1	1	1	register [3927]	
1	0	0	0	register [3928]	
1	0	0	1	register [3929]	
1	0	1	0	register [3930]	
1	0	1	1	register [3931]	
1	1	0	0	register [3932]	
1	1	0	1	register [3933]	
1	1	1	0	register [3934]	
1	1	1	1	register [3935]	MSB

This macrocell, when programmed for a LUT function, uses a 16-bit register to define their output function:

4-Bit LUT0 is defined by registers [3935:3920]

Table 47: 4-bit LUT Standard Digital Functions

Function	MSB															LSB
AND-4	1	0	0	0	0	0	0	0	0	0	0	0	0	0	0	0
NAND-4	0	1	1	1	1	1	1	1	1	1	1	1	1	1	1	1
OR-4	1	1	1	1	1	1	1	1	1	1	1	1	1	1	1	0
NOR-4	0	0	0	0	0	0	0	0	0	0	0	0	0	0	0	1
XOR-4	0	1	1	0	1	0	0	1	1	0	0	1	0	1	1	0
XNOR-4	1	0	0	1	0	1	1	0	0	1	1	0	1	0	0	1

GreenPAK Programmable Mixed-Signal Matrix with Asynchronous State Machine and Dual Supply

7.8 WAKE AND SLEEP CONTROLLER

The SLG46880/81 has a Wake and Sleep (WS) function for ACMP0H and ACMP1H. The macrocell CNT/DLY0 can be reconfigured for this purpose registers [897:896] = 11 and register [910] = 1. The WS serves for power saving, it allows to switch on and off selected ACMPs on selected bit of 16-bit counter.

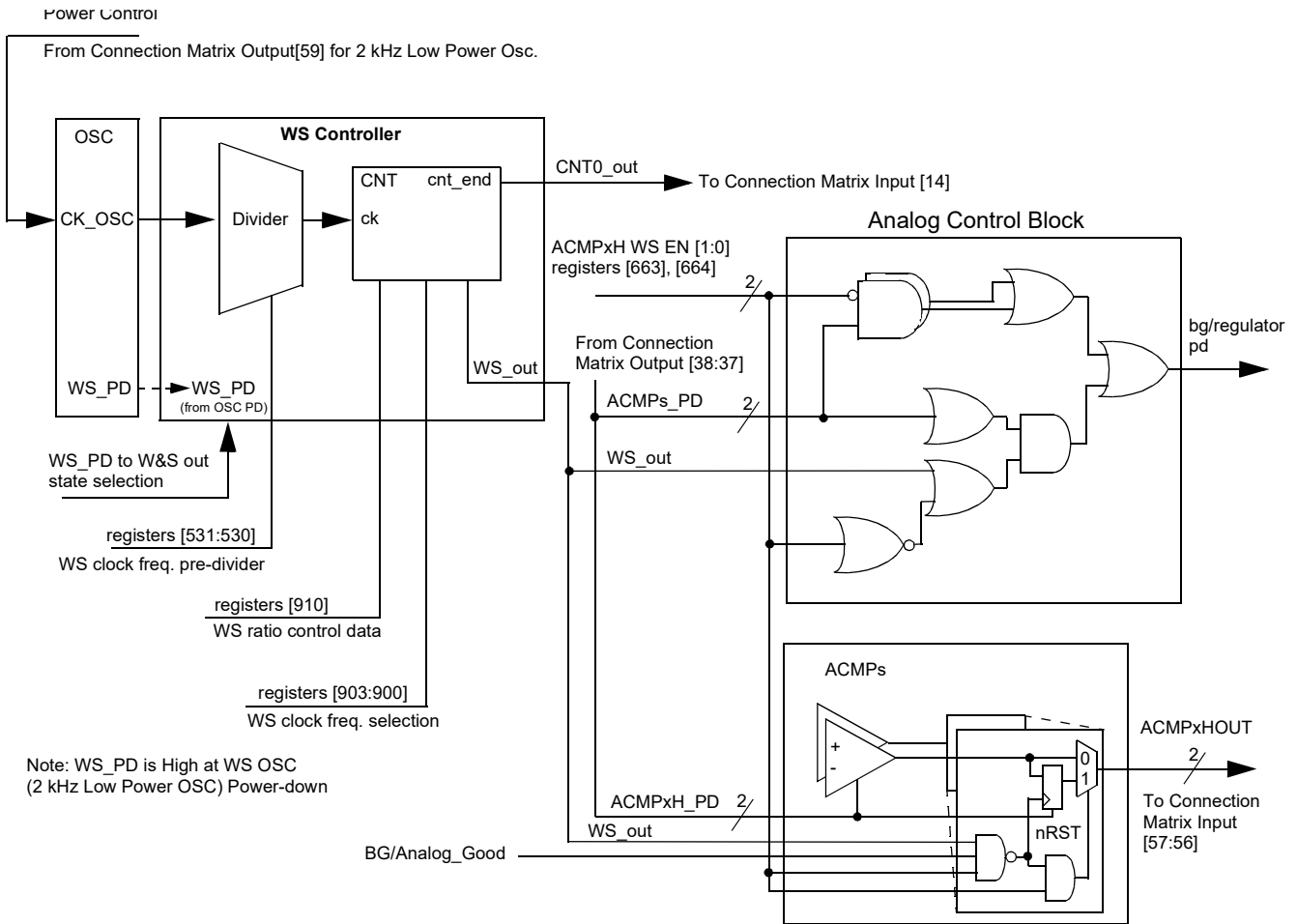

Figure 55: WS Controller

GreenPAK Programmable Mixed-Signal Matrix with Asynchronous State Machine and Dual Supply

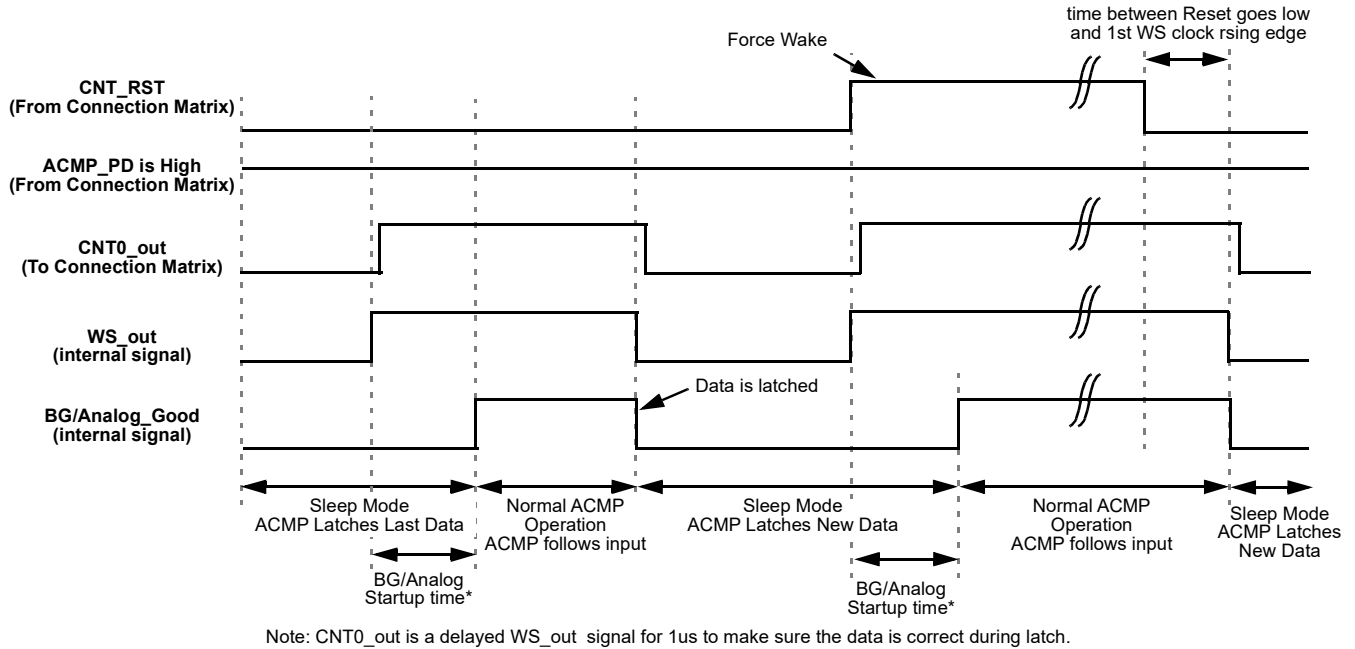

Figure 56: Wake/Sleep Timing Diagram, Normal Wake Mode, Counter Reset is Used

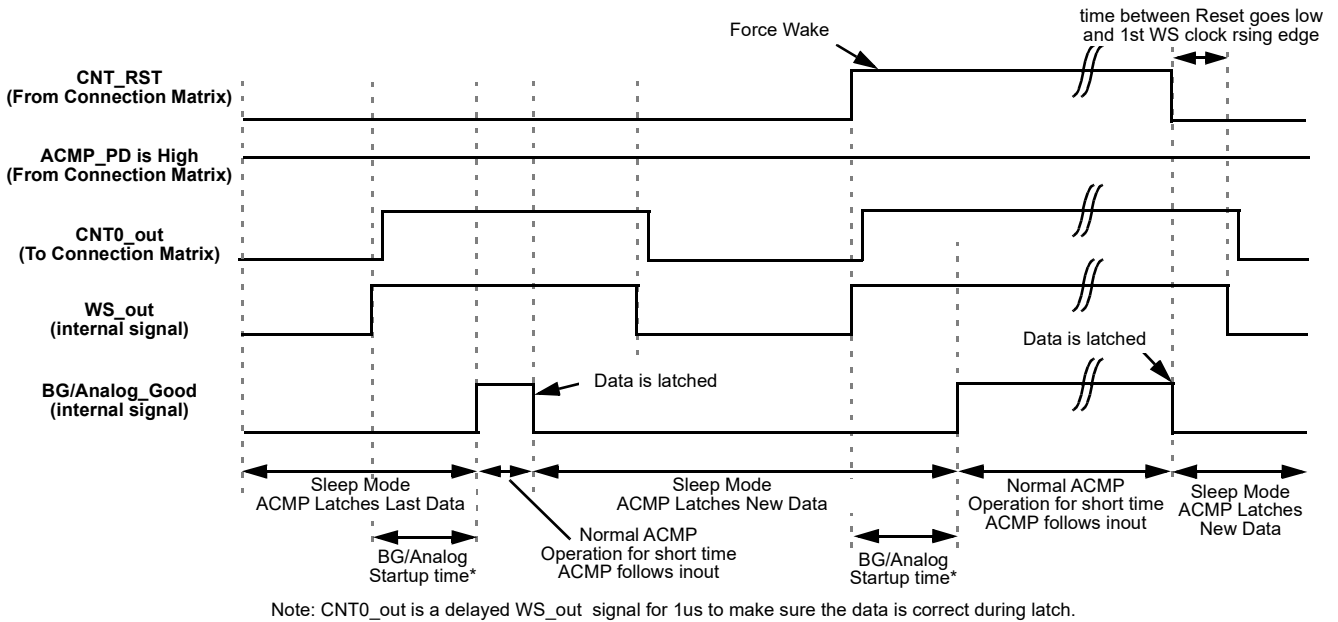

Figure 57: Wake/Sleep Timing Diagram, Short Wake Mode, Counter Reset is Used

GreenPAK Programmable Mixed-Signal Matrix with Asynchronous State Machine and Dual Supply

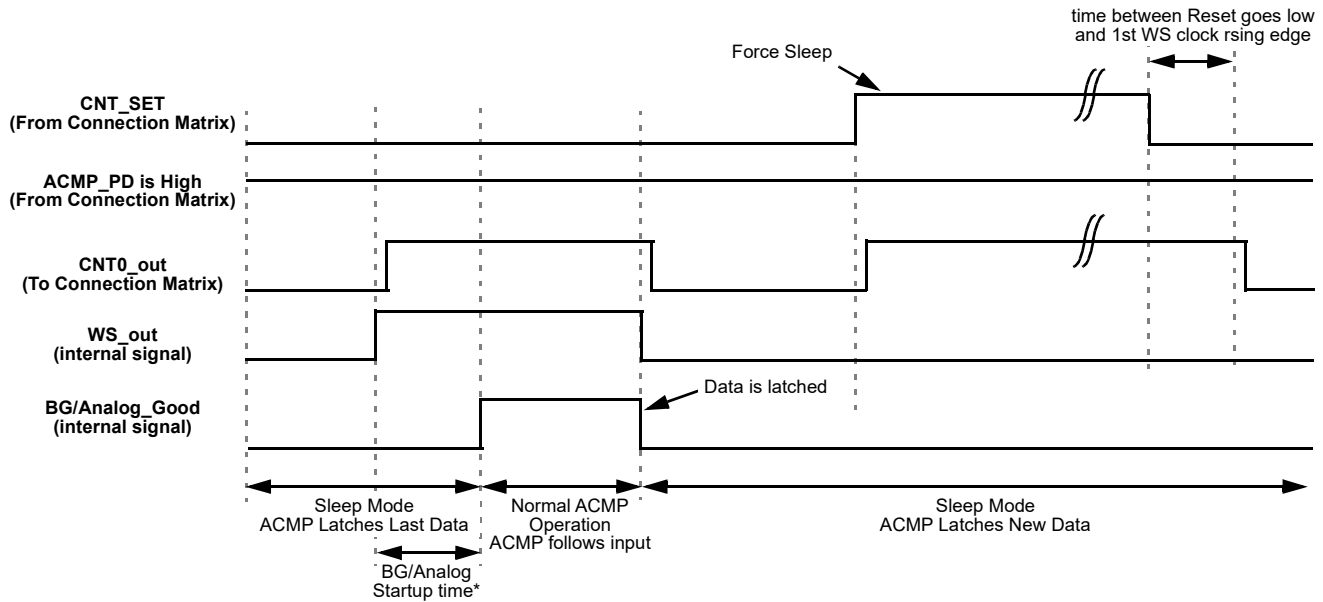

Figure 58: Wake/Sleep Timing Diagram, Normal Wake Mode, Counter Set is Used

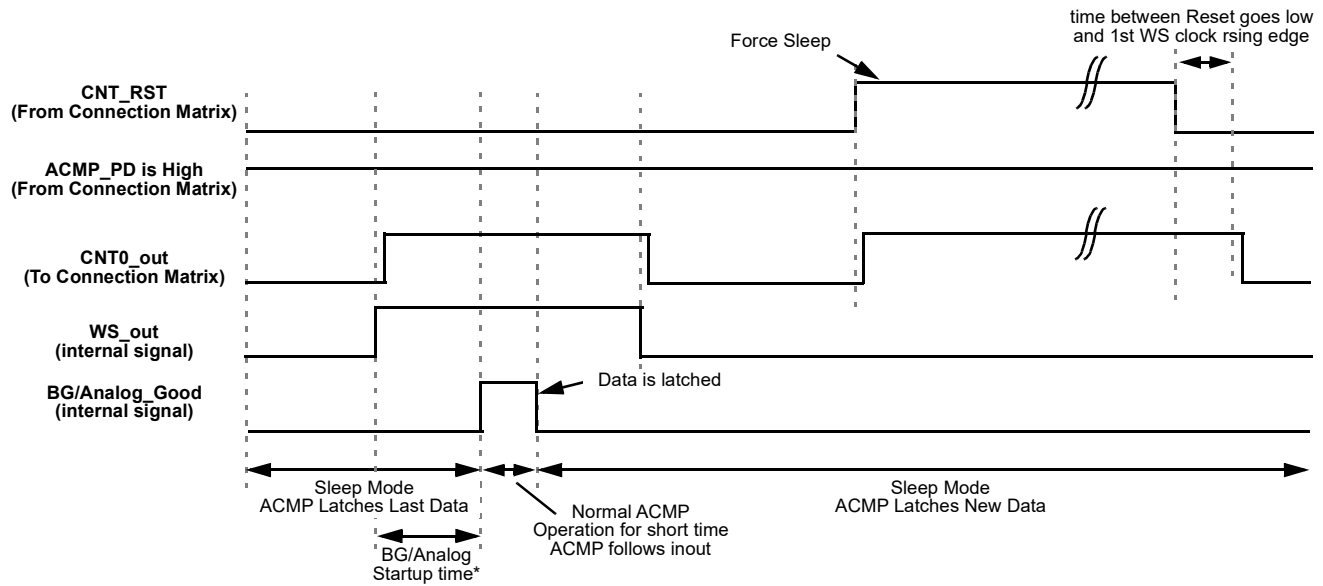

Figure 59: Wake/Sleep Timing Diagram, Short Wake Mode, Counter Set is Used

Note: If low power BG is powered on/off by WS, the wake time should be longer than 2.1 ms. The BG/analog start up time will take maximal 2 ms. If low power BG is always on, OSC0 period is longer than required wake time. The short wake mode can be used to reduce the current consumption.

To use any ACMPxH under WS controller the following settings must be done:

- ACMPxH Power Up Input from matrix = 1 (for each ACMPxH separately).

GreenPAK Programmable Mixed-Signal Matrix with Asynchronous State Machine and Dual Supply

- CNT/DLY0 must be set to Wake and Sleep Controller function (for all ACMPxH).
- Register WS → enable (for each ACMPxH separately).
- CNT/DLY0 set/reset input = 0 (for all ACMPxH).

As the OSC any oscillator with any pre-divider can be used. The user can select a period of time while the ACMPxH is sleeping in a range of 1 to 65535 clock cycles. Before they are sent to sleep their outputs are latched, so the ACMPs remain their state (High or Low) while sleeping.

WS controller has the following settings:

- Wake and Sleep Output State (High/Low)
 - If OSC is powered off (Power-down option is selected; Power-down input = 1) and Wake and Sleep Output State = High, the ACMPxH is continuously on.
 - If OSC is powered off (Power-down option is selected; Power-down input = 1) and Wake and Sleep Output State = Low, the ACMPxH is continuously off.
 - Both cases WS function is turned off.
- Counter Data (Range: 1 to 65535)
 - User can select wake and sleep ratio of the ACMP; counter data = sleep time, one clock = wake time.
- Q mode - defines the state of WS counter data when Set/Reset signal appears
 - Reset - when active signal appears, the WS counter will reset to zero and High level signal on its output will turn on the ACMPs. When Reset signal goes out, the WS counter will go Low and turn off the ACMPxH until the counter counts up to the end.
 - Set - when active signal appears, the WS counter will stop and Low level signal on its output will turn off the ACMPxH. When Set signal goes out, the WS counter will go on counting and High level signal will turn on the ACMPxH while counter is counting up to the end.

Note: The OSC0 matrix power down to control ACMP W/S is not supported for short wait time option.

- Edge Select defines the edge for Q mode
 - High level Set/Reset - switches mode Set/Reset when level is High

Note: Q mode operates only in case of "High Level Set/Reset".

- Wake time selection - time required for wake signal to turn the ACMPxH on

Normal Wake Time - when WS signal is High, it takes BG/analog start up time to turn the ACMPs on. They will stay on until WS signal is Low again. Wake time is one clock period. It should be longer than BG turn on time and minimal required comparing time of the ACMP.

Short Wake Time - when WS signal is High, it takes BG/analog start up time to turn the ACMPs on. They will stay on for 1 μ s and turn off regardless of WS signal. The WS signal width does not matter.

- Keep - pauses counting while Keep = 1
- Up - reverses counting
 - If Up = 1, CNT is counting up from user selected value to 65535.
 - If Up = 0, CNT is counting down from user selected value to 0.

GreenPAK Programmable Mixed-Signal Matrix with Asynchronous State Machine and Dual Supply

7.8.1 WS Register Settings

Table 48: WS Register Settings

Signal Function	Register Bit Address	Register Definition
Counter/delay0 Clock Source Select	registers [903:900]	0000: OSC2 0001: OSC2 /4 0010: OSC1 0011: OSC1 /8 0100: OSC1 /64 0101: OSC1 /512 0110: OSC0 0111: OSC0 /8 1000: OSC0 /64 1001: OSC0 /512 1010: OSC0 /4096 1011: OSC0 /32768 1100: OSC0 /262144 1101: CNT4 Overflow 1110: External 1111: Reserved
ACMP0H Wake & Sleep function Enable	register [663]	0: Disable 1: Enable
ACMP1H Wake & Sleep function Enable	register [664]	0: Disable 1: Enable
Wake Sleep Output State When WS Oscillator is Power-down if DLY/CNT0 Mode Selection is "11"	register [909]	0: Low 1: High
DLY/CNT0 (16bits, [15:0] = [3935:3920]) Control Data	registers [3935:3920]	1 - 65535

GreenPAK Programmable Mixed-Signal Matrix with Asynchronous State Machine and Dual Supply

8 Analog Comparators

There are four General Purpose Rail-to-Rail Analog Comparator (ACMP) macrocells in the SLG46880/81. In order for the ACMP cells to be used in a GreenPAK design, the power up signals (ACMP0H PWR UP, ACMP1H PWR UP, ACMP2L PWR UP, and ACMP3L PWR UP) need to be active. By connecting to signals coming from the Connection Matrix, it is possible to have each ACMP be on continuously, off continuously, or switched on periodically based on a digital signal coming from the Connection Matrix. When ACMP is powered down, output is low.

Two of the four General Purpose Rail-to-Rail Analog Comparators are optimized for high speed operation (ACMP0H and ACMP1H), and two of the four are optimized for low power operation (ACMP2L and ACMP3L).

Each of the ACMP cells has a positive input signal that can be provided by a variety of external sources, and can also have a selectable gain stage before connection to the analog comparator. Each of the ACMP cells has a negative input signal that is either created from an internal Vref or provided by way of the external sources.

PWR UP = 1 → ACMP is powered up.

PWR UP = 0 → ACMP is powered down.

During power-up, the ACMP output will remain LOW, and then become valid 51.4 μs (max) after power up signal goes high for ACMP0H and ACMP1H, and become valid 326.6 μs (max) after power up signal goes high for ACMP2L and ACMP3L. Input bias current < 1 nA (typ). The Gain divider is unbuffered and consists of 2 MΩ resistors.

Each High Speed ACMP (ACMP0H and ACMP1H) has an optional Rail-to-Rail Input Buffer, which can be used along with the Gain divider to increase ACMP input resistance. However, Input buffer will increase an input offset voltage.

Each cell also has a hysteresis selection, to offer hysteresis of (0, 32, 64, 192) mV. The hysteresis option is available when using an internal Vref only.

ACMP0H IN+ options are GPIO10, buffered GPIO10, V_{DD}

ACMP1H IN+ options are GPIO11, buffered GPIO11, ACMP0H IN+ MUX output

ACMP2L IN+ options are GPO5, ACMP0H IN+ MUX output, ACMP1H IN+ MUX output

ACMP3L IN+ options are GPO6, ACMP2L IN+ MUX output, Temp Sensor OUT

GreenPAK Programmable Mixed-Signal Matrix with Asynchronous State Machine and Dual Supply

8.1 ACMP0H BLOCK DIAGRAM

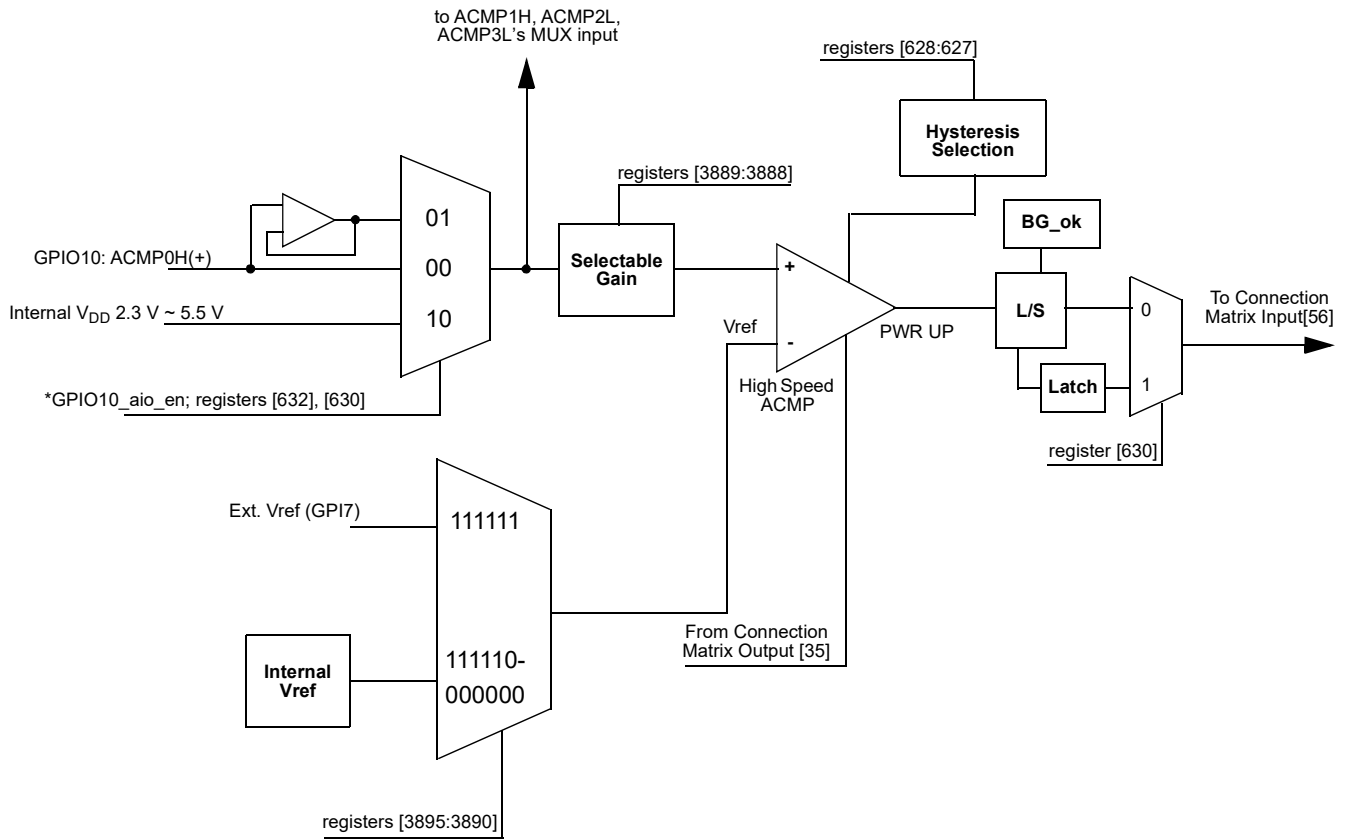

Figure 60: ACMP0H Block Diagram

GreenPAK Programmable Mixed-Signal Matrix with Asynchronous State Machine and Dual Supply

8.2 ACMP1H BLOCK DIAGRAM

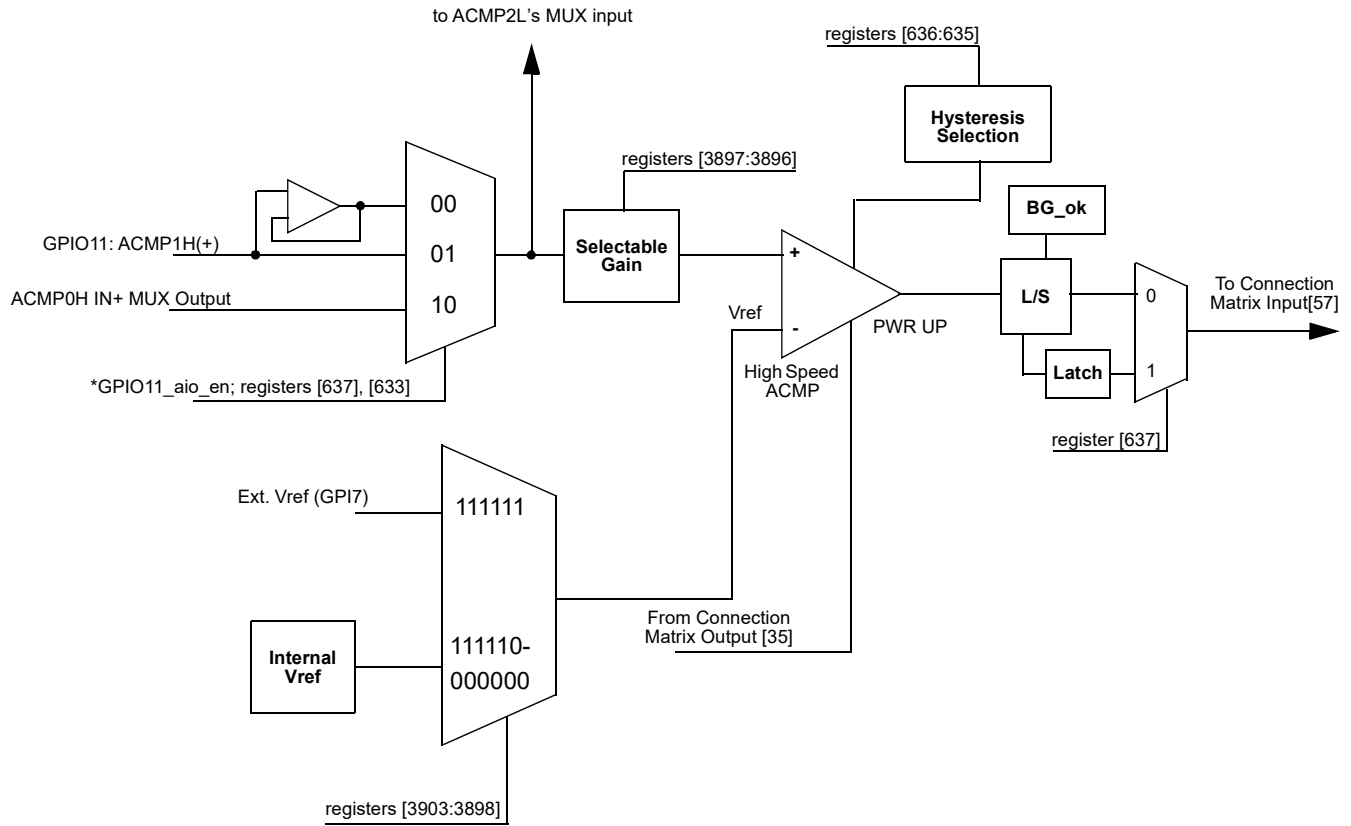

Figure 61: ACMP1H Block Diagram

GreenPAK Programmable Mixed-Signal Matrix with Asynchronous State Machine and Dual Supply

8.3 ACMP2L BLOCK DIAGRAM

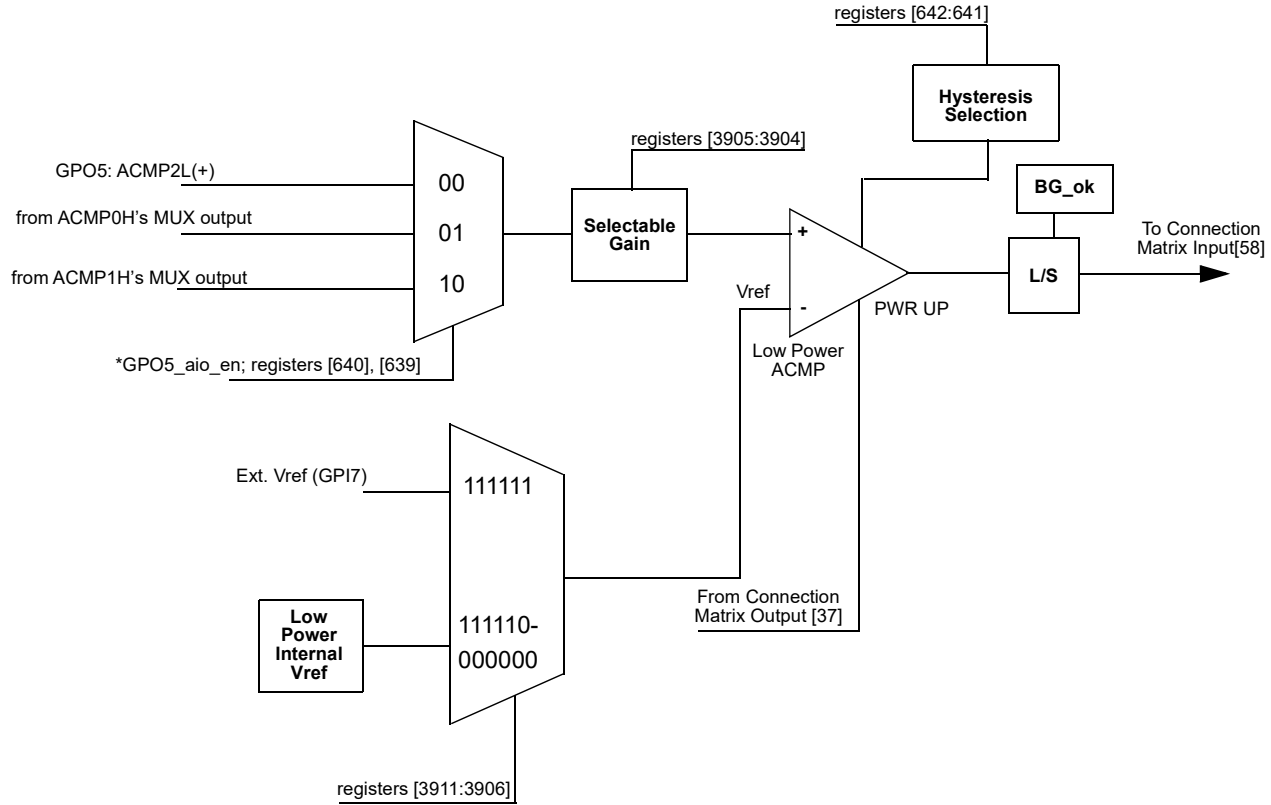

Figure 62: ACMP2L Block Diagram

8.4 ACMP3L BLOCK DIAGRAM

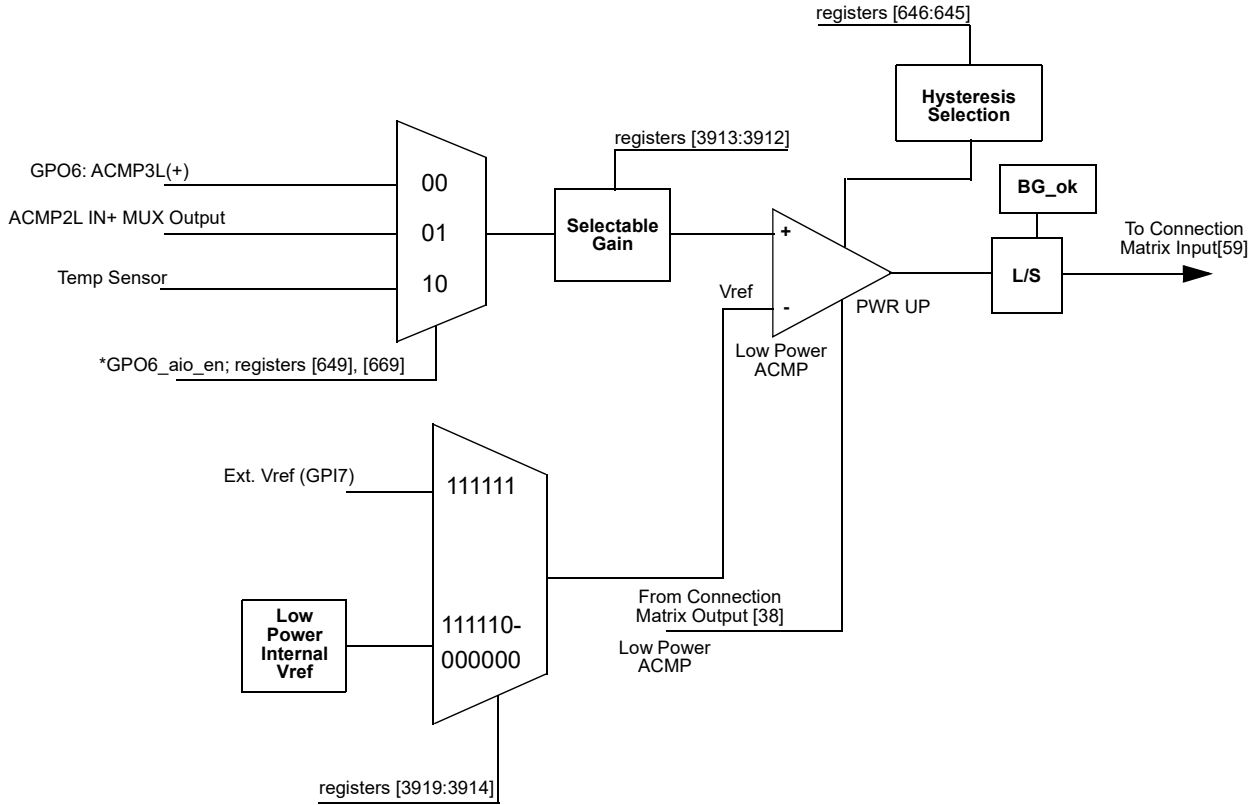

Figure 63: ACMP3L Block Diagram

8.5 ACMP TYPICAL PERFORMANCE

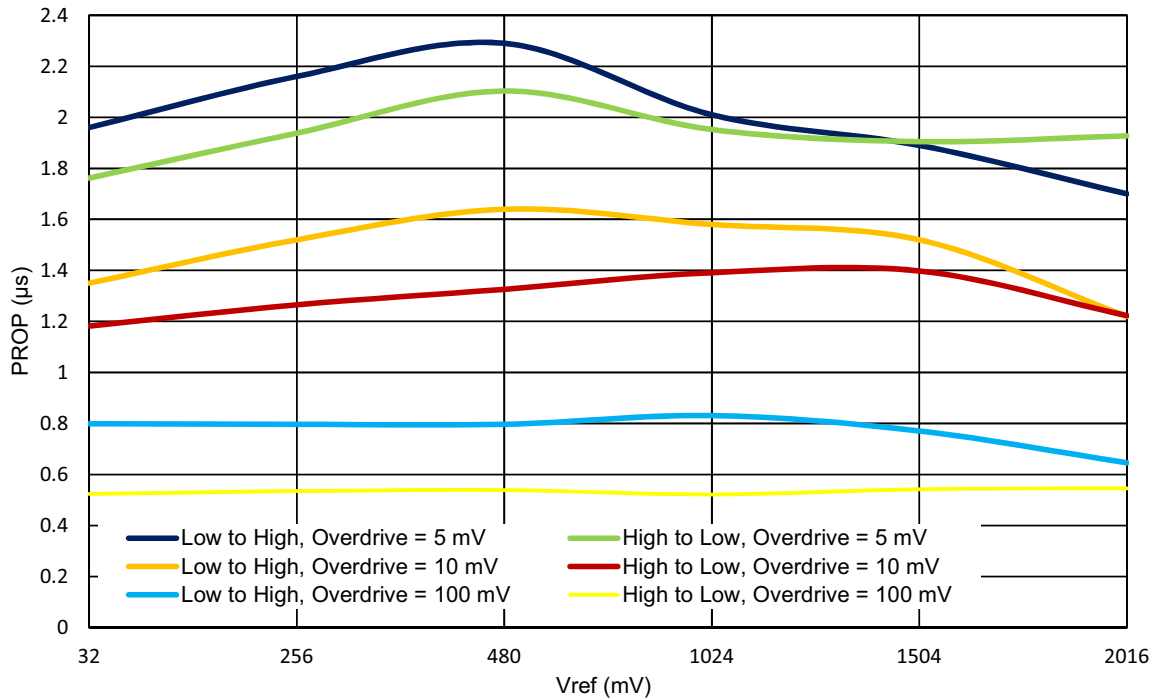

Figure 64: Typical Propagation Delay vs. Vref for ACMPxH at T = 25 °C, Gain = 1, Buffer - Disabled, Hysteresis = 0

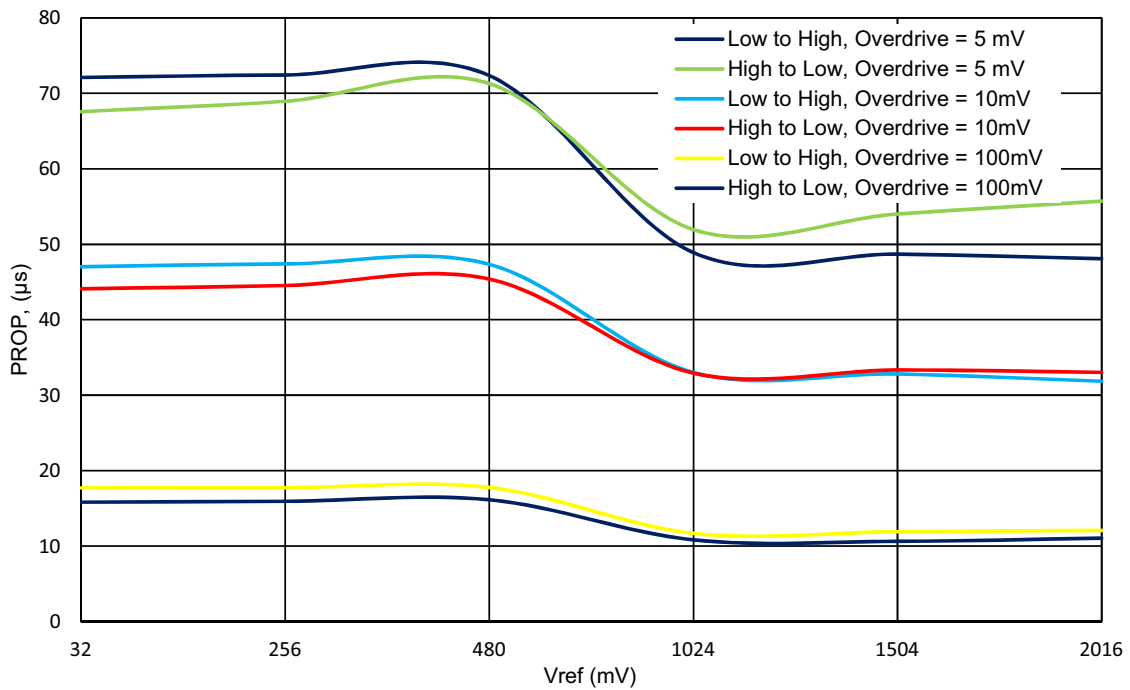

Figure 65: Typical Propagation Delay vs. Vref for ACMPxL at T = 25 °C, Gain = 1, Buffer - Disabled, Hysteresis = 0

GreenPAK Programmable Mixed-Signal Matrix with Asynchronous State Machine and Dual Supply

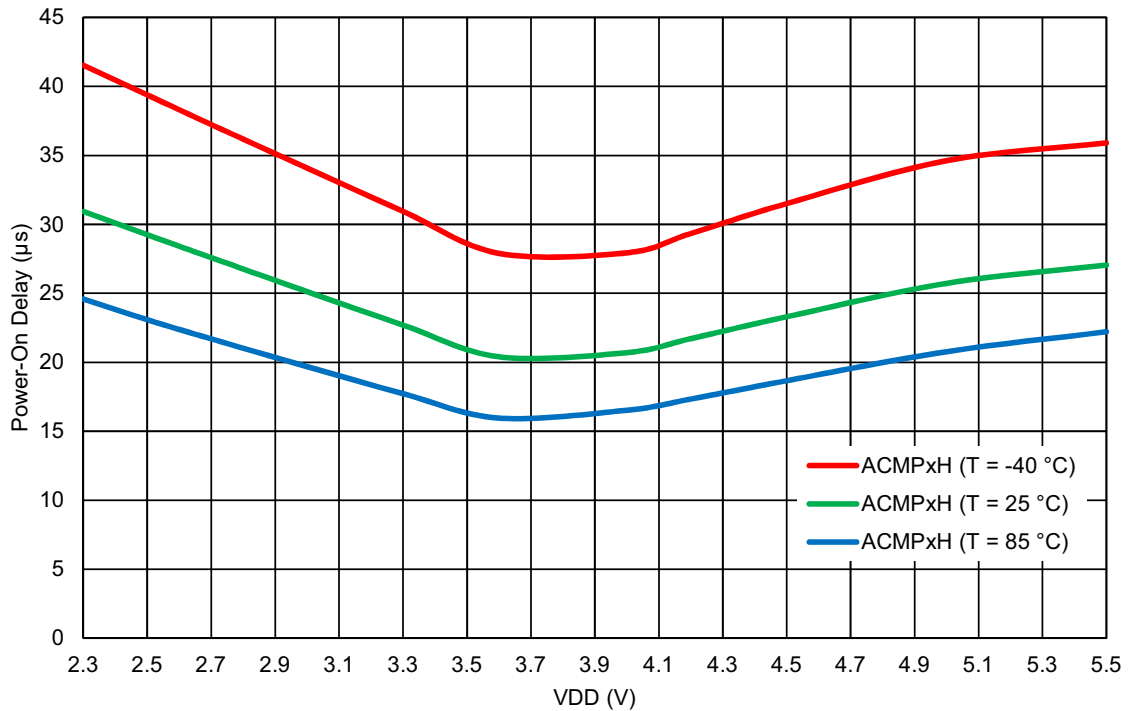

Figure 66: ACMPxH Power-On Delay vs. V_{DD}

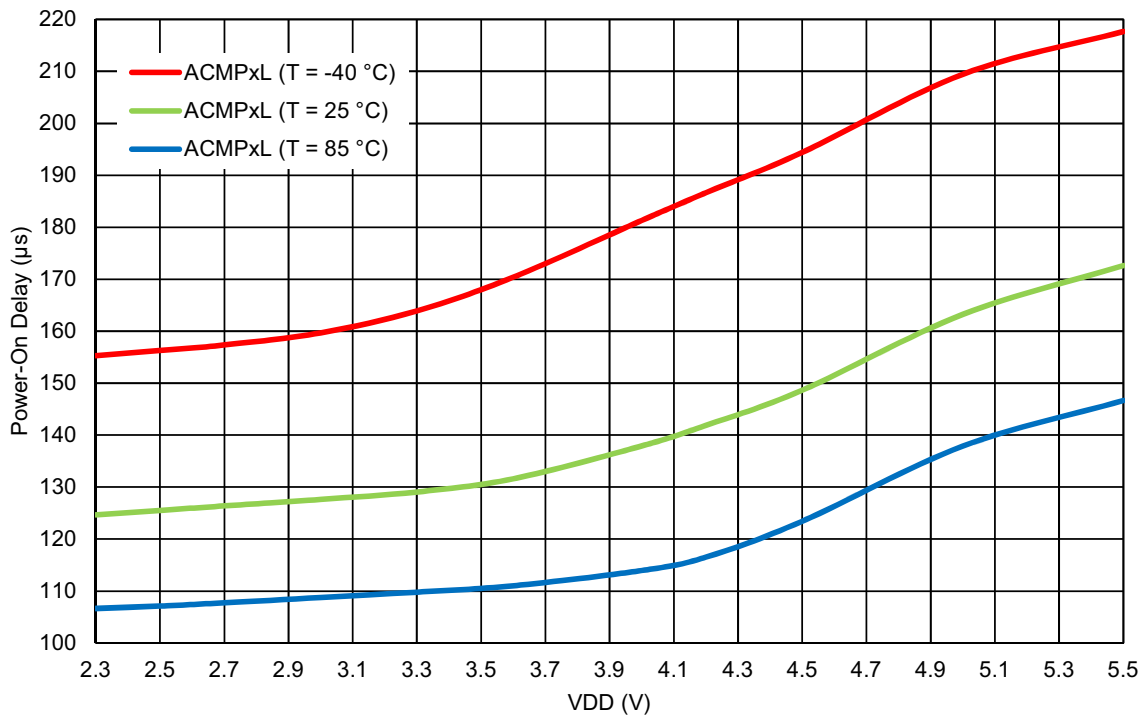

Figure 67: ACMPxL Power-On Delay vs. V_{DD}

GreenPAK Programmable Mixed-Signal Matrix with Asynchronous State Machine and Dual Supply

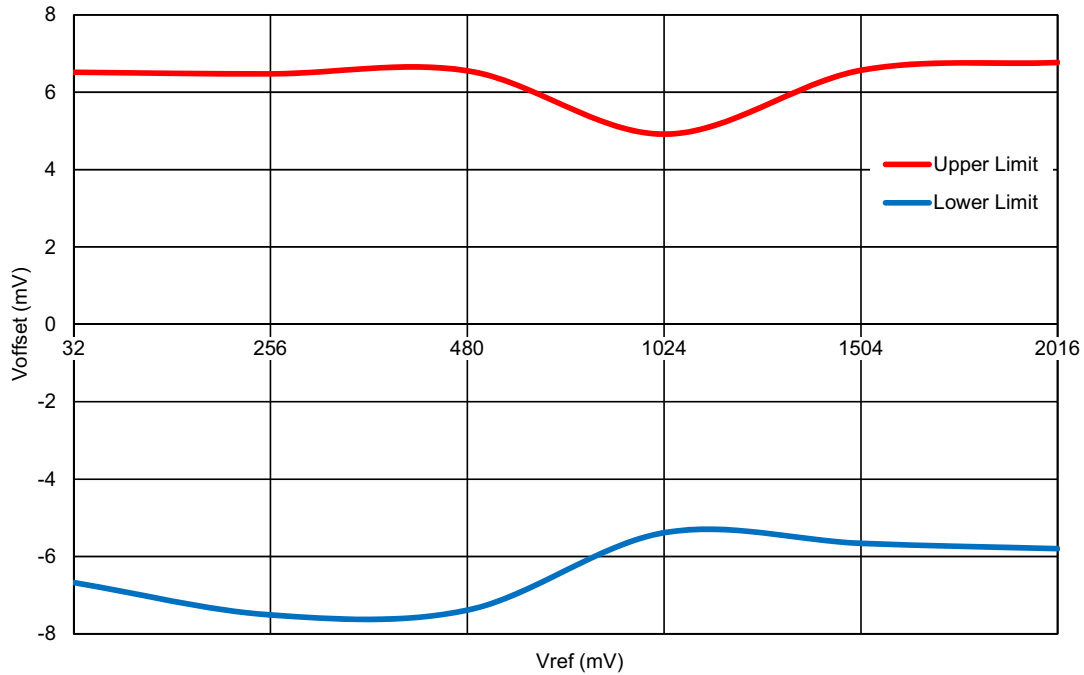

Figure 68: ACMPxH Input Offset Voltage vs. Vref at T = -40 °C to 85 °C, Input Buffer Disabled

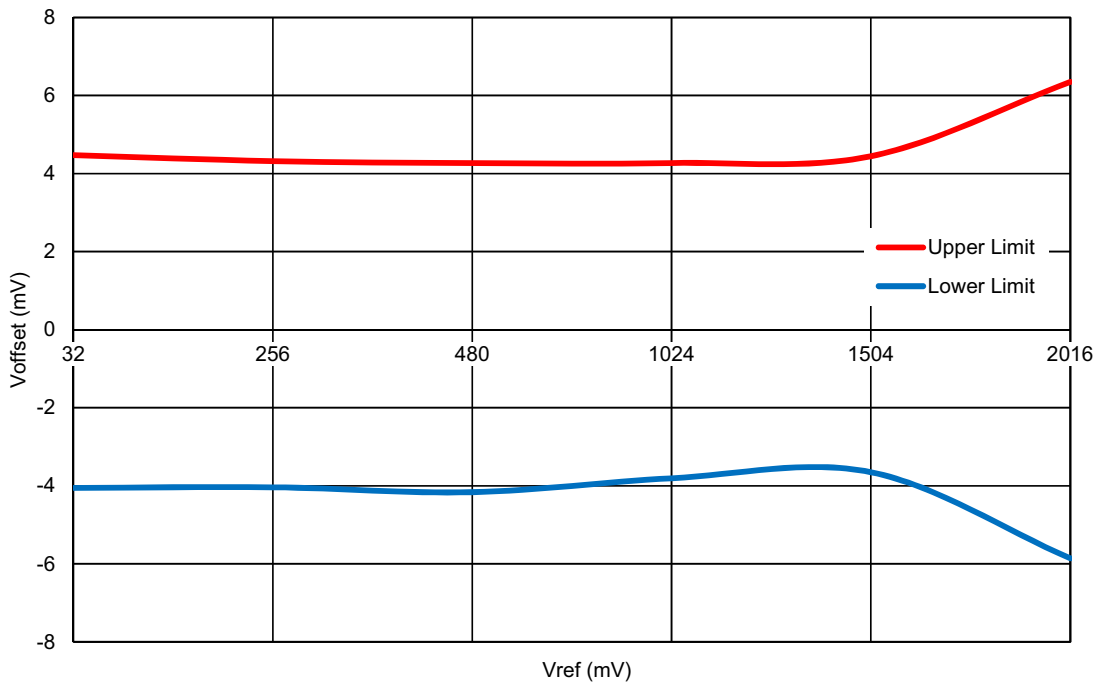

Figure 69: ACMPxL Input Offset Voltage vs. Vref at T = -40 °C to 85 °C, Input Buffer Disabled

GreenPAK Programmable Mixed-Signal Matrix with Asynchronous State Machine and Dual Supply

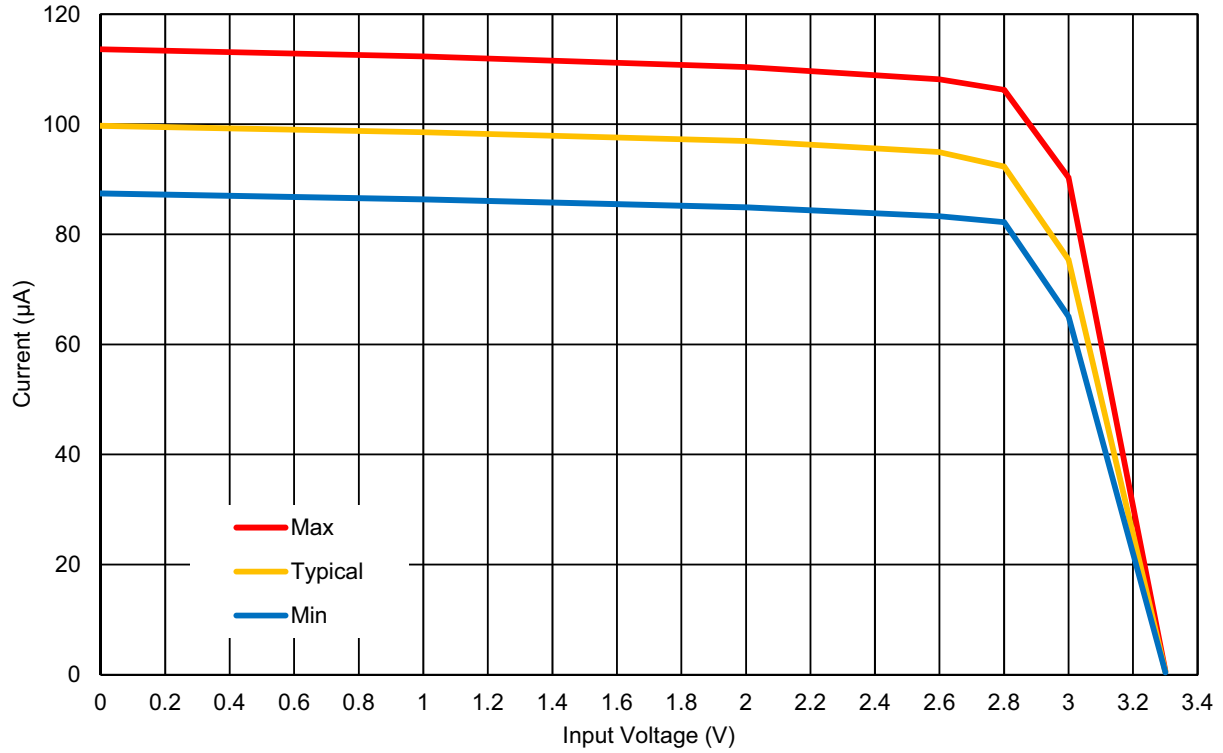

Figure 70: ACMP Input Current Source vs. Input Voltage at T = -40 °C to 85 °C, V_{DD} = 3.3 V

9 Programmable Delay/Edge Detector

The SLG46880/81 has a programmable time delay logic cell available that can generate a delay that is selectable from one of four timings (time1) configured in the GreenPAK Designer. The programmable time delay cell can generate one of four different delay patterns, rising edge detection, falling edge detection, both edge detection, and both edge delay. These four patterns can be further modified with the addition of delayed edge detection, which adds an extra unit of delay as well as glitch rejection during the delay period. See Figure 72 for further information.

Note: The input signal must be longer than the delay, otherwise it will be filtered out.

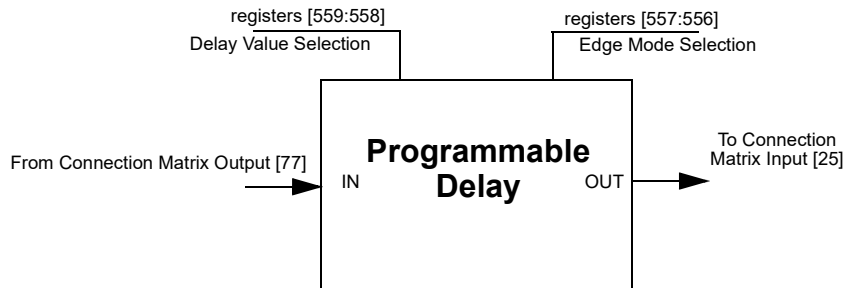

Figure 71: Programmable Delay

9.1 PROGRAMMABLE DELAY TIMING DIAGRAM - EDGE DETECTOR OUTPUT

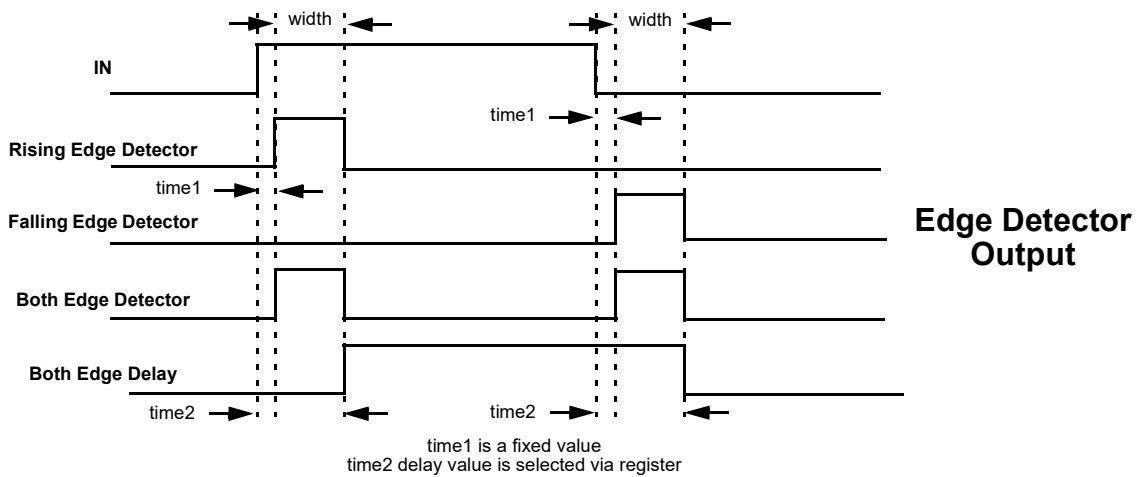

Figure 72: Edge Detector Output

Please refer to Table 14.

10 Additional Logic Function

The SLG46880/81 has one additional logic function that is connected directly to the Connection Matrix inputs and outputs. There is one deglitch filter, with edge detector function.

10.1 DEGLITCH FILTER/EDGE DETECTOR

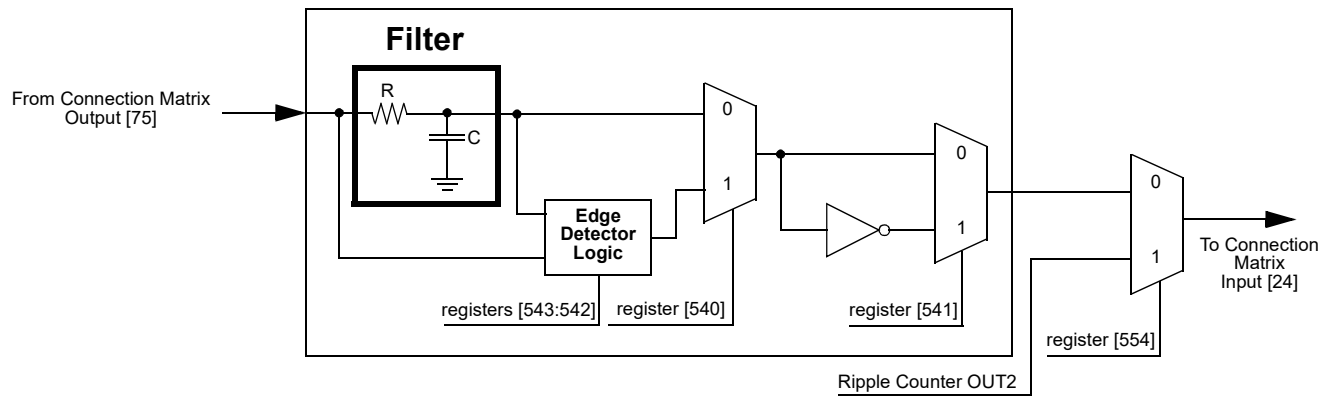

Figure 73: Deglitch Filter/Edge Detector

GreenPAK Programmable Mixed-Signal Matrix with Asynchronous State Machine and Dual Supply

11 Voltage Reference

11.1 VOLTAGE REFERENCE OVERVIEW

The SLG46880/81 has a Voltage Reference (Vref) Macrocell to provide references to the four analog comparators. This macrocell can supply a user selection of fixed voltage references, or temperature sensor output. The macrocell also has the option to output reference voltages on GPIO2 and GPIO9. See [Table 49](#) for the available selections for each analog comparator. Also, see [Figure 74](#), which shows the reference output structure.

11.2 VREF SELECTION TABLE

Table 49: Vref Selection Table

SEL[5:0]	Vref	SEL[5:0]	Vref
0	0.032	32	1.056
1	0.064	33	1.088
2	0.096	34	1.12
3	0.128	35	1.152
4	0.16	36	1.184
5	0.192	37	1.216
6	0.224	38	1.248
7	0.256	39	1.28
8	0.288	40	1.312
9	0.32	41	1.344
10	0.352	42	1.376
11	0.384	43	1.408
12	0.416	44	1.44
13	0.448	45	1.472
14	0.48	46	1.504
15	0.512	47	1.536
16	0.544	48	1.568
17	0.576	49	1.6
18	0.608	50	1.632
19	0.64	51	1.664
20	0.672	52	1.696
21	0.704	53	1.728
22	0.736	54	1.76
23	0.768	55	1.792
24	0.8	56	1.824
25	0.832	57	1.856
26	0.864	58	1.888
27	0.896	59	1.92
28	0.928	60	1.952
29	0.96	61	1.984
30	0.992	62	2.016
31	1.024	63	External

GreenPAK Programmable Mixed-Signal Matrix with Asynchronous State Machine and Dual Supply

11.3 TRUTH TABLE FOR VREF0 BUFFER AND OUTPUT SWITCH CONTROL

Table 50: VrefO0 Truth Table

Function Enable	VrefO0 Source Selection	VrefO0 Buffer Selection	VrefO0 Buffer Enable	Matrix out78	TS PD Selection	TS PD Register Control	GPIO9 Analog Mode Enable	Buffer state	Output switch	Note	
	register [655:654]	register [623]	register [653]		register [651]	register [650]	register [856:855]= 11, means enable				
None	00	0	0	0	0	0	Disable	Off	Off	VrefO0 is all off	
ACMP0H_Vref	01	0	0	0	0	0	Disable	Off	Off	VrefO0 select ACMP0H; output has no buffer; pd comes from register [653]	
	01	0	0	0	0	0	Enable	Off	On		
	01	0	1	0	0	0	Disable	On	Off	VrefO0 select ACMP0H; output has buffer; pd comes from register [653]	
	01	0	1	0	0	0	Enable	On	On		
	01	1	0	0	0	0	Disable	Off	Off	VrefO0 select ACMP0H; output has no buffer; pd comes from matrix78	
	01	1	0	0	0	0	Enable	Off	On		
	01	1	0	1	0	0	Disable	On	Off		
ACMP1H_Vref	10	0	0	0	0	0	Disable	Off	Off	VrefO0 select ACMP1H; output has no buffer; pd comes from register [653]	
	10	0	0	0	0	0	Enable	Off	On		
	10	0	1	0	0	0	Disable	On	Off	VrefO0 select ACMP1H; output has buffer; pd comes from register [653]	
	10	0	1	0	0	0	Enable	On	On		
	10	1	0	0	0	0	Disable	Off	Off	VrefO0 select ACMP1H; output has no buffer; pd comes from matrix78	
	10	1	0	0	0	0	Enable	Off	On		
	10	1	0	1	0	0	Disable	On	Off		
TS function	11	0	0	0	0	0	Disable	Off	Off	TS enable comes from register [650]	
	11	0	0	0	0	0	Enable	Off	Off		
	11	0	0	0	0	1	Disable	On	Off		
	11	0	0	0	0	0	0	Enable	On	On	TS enable comes from Matrix78
	11	0	0	0	0	0	Disable	Off	Off		
	11	0	0	0	0	0	0	Enable	Off	Off	
	11	0	0	1	0	0	0	Disable	On	Off	
11	0	0	1	0	0	0	Enable	On	On		

11.4 TRUTH TABLE FOR VREF1 BUFFER AND OUTPUT SWITCH CONTROL

Table 51: VrefO1 Truth Table

Function Enable	VrefO1 Source Selection	VrefO1 Buffer Selection	GPIO2 Analog Mode Enable	Buffer state	Output switch	Note
	registers [658:657]	register [656]	registers [708:707]= 11, means enable			
None	00	0	Disable	Off	Off	VrefO1 is all off
ACMP2L_Vref	01	0	Disable	Off	Off	VrefO1 select ACMP2L; output has no buffer; pd come from register [656]
	01	0	Enable	Off	On	
	01	1	Disable	On	Off	VrefO1 select ACMP2L; output has buffer; pd come from register [656]
	01	1	Enable	On	On	

GreenPAK Programmable Mixed-Signal Matrix with Asynchronous State Machine and Dual Supply

Table 51: VrefO1 Truth Table(Continued)

Function Enable	VrefO1 Source Selection	VrefO1 Buffer Selection	GPIO2 Analog Mode Enable	Buffer state	Output switch	Note
	registers [658:657]	register [656]	registers [708:707]= 11, means enable			
ACMP3L_Vref	10	0	Disable	Off	Off	VrefO1 select ACMP2L; output has no buffer; pd come from register [656]
	10	0	Enable	Off	On	
	10	1	Disable	On	Off	VrefO1 select ACMP2L; output has buffer; pd come from register [656]
	10	1	Enable	On	On	

valid output mode

11.5 VREF BLOCK DIAGRAM

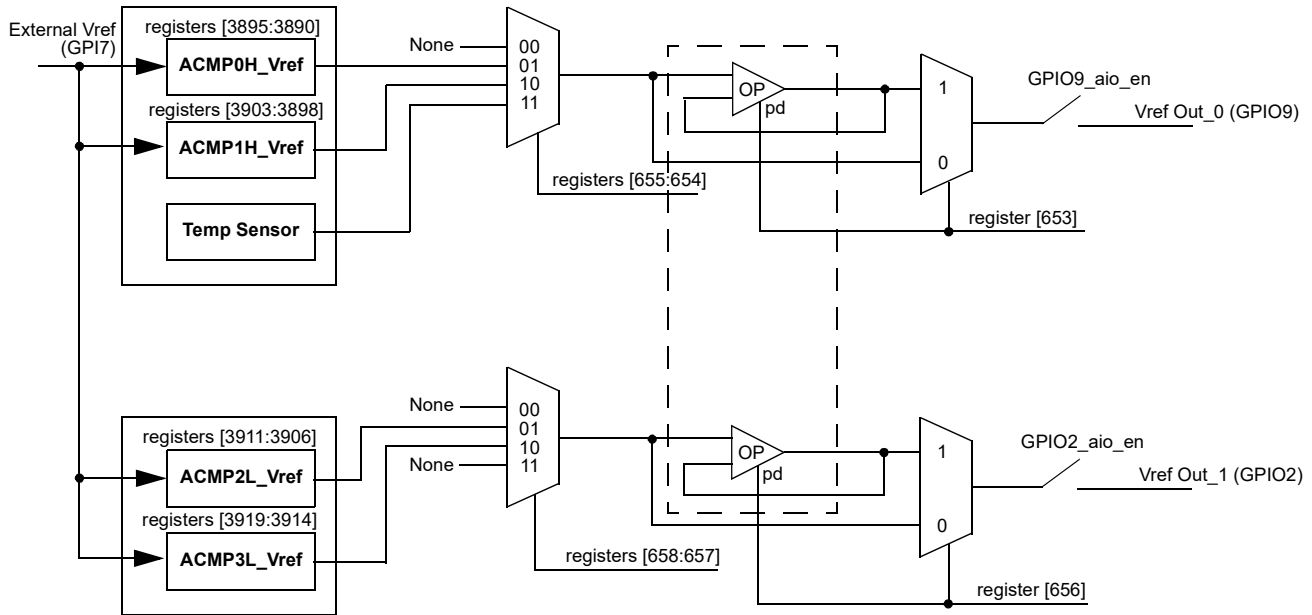

Figure 74: Voltage Reference Block Diagram

GreenPAK Programmable Mixed-Signal Matrix with Asynchronous State Machine and Dual Supply

11.6 VREF LOAD REGULATION

Note 1 It is not recommended to use Vref connected to external pin without buffer.

Note 2 Vref buffer performance is not guaranteed at $V_{DD} < 2.7\text{ V}$.

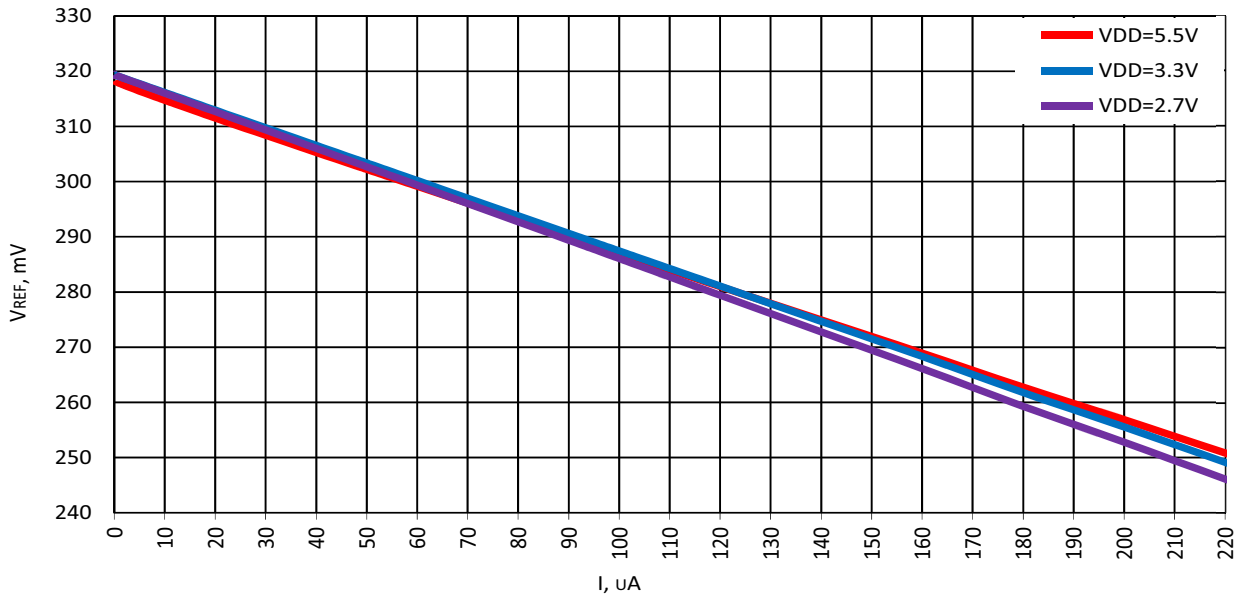

Figure 75: Typical Load Regulation, Vref = 320 mV, T = -40 °C to +85 °C, Buffer - Enable

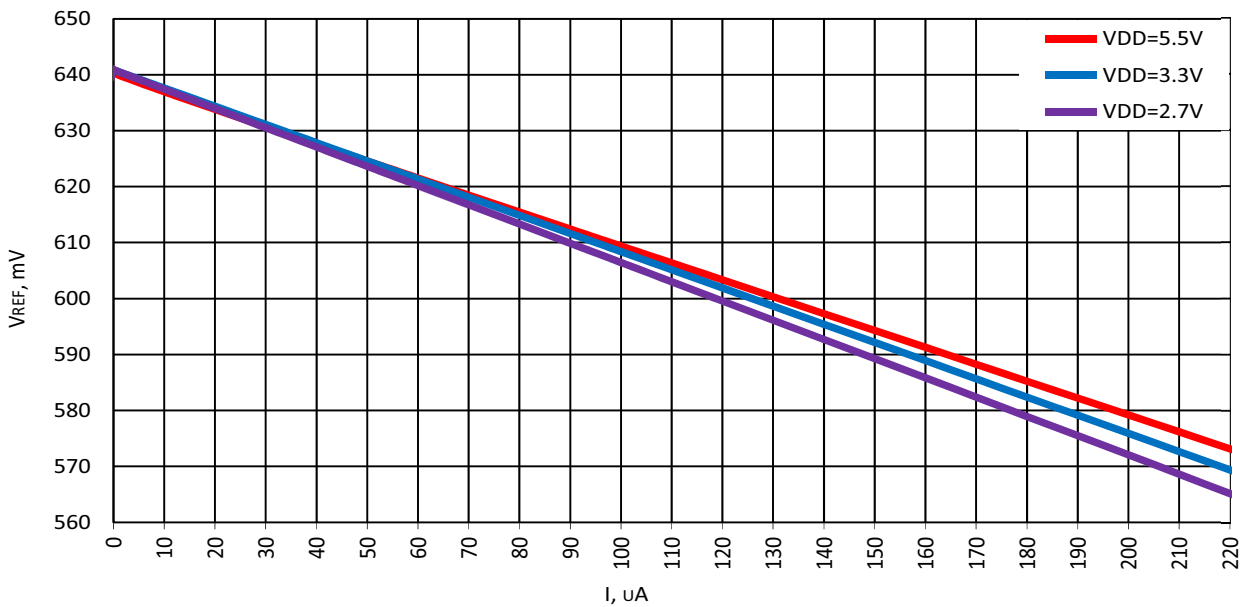

Figure 76: Typical Load Regulation, Vref = 640 mV, T = -40 °C to +85 °C, Buffer - Enable

GreenPAK Programmable Mixed-Signal Matrix with Asynchronous State Machine and Dual Supply

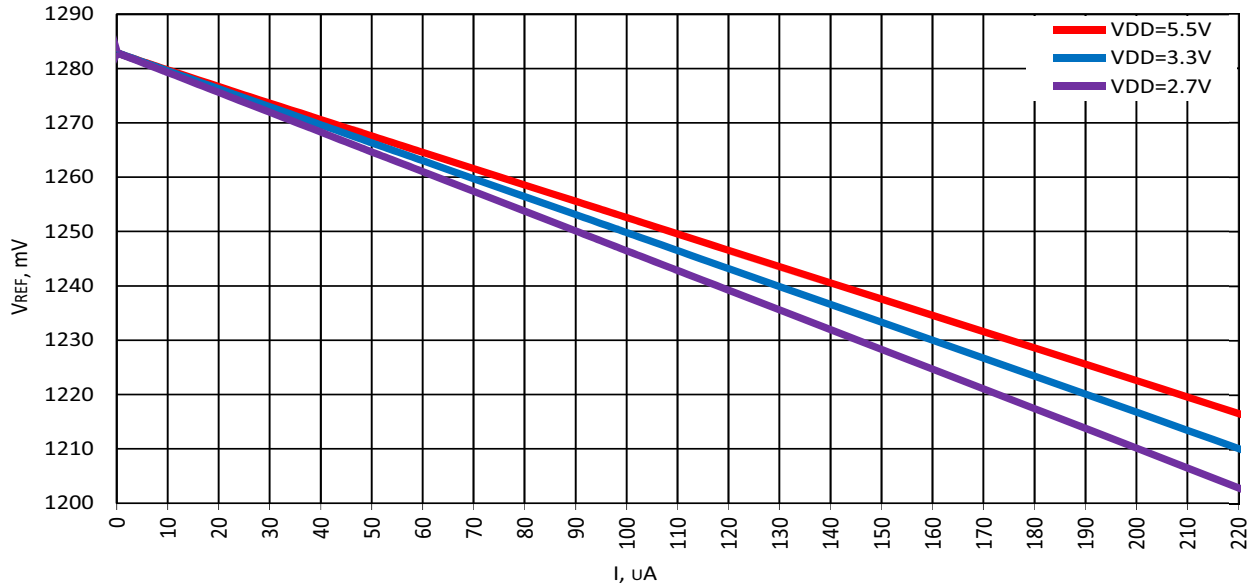

Figure 77: Typical Load Regulation, Vref = 1280 mV, T = -40 °C to +85 °C, Buffer - Enable

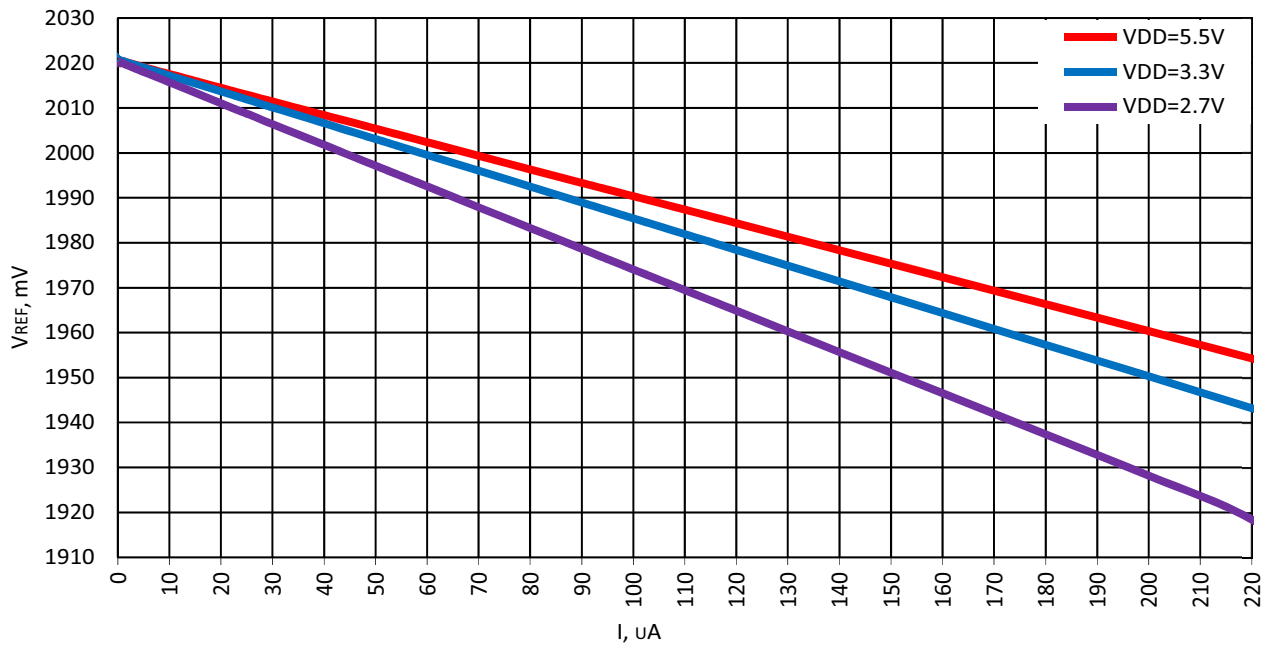

Figure 78: Typical Load Regulation, Vref = 2016 mV, T = -40 °C to +85 °C, Buffer - Enable

GreenPAK Programmable Mixed-Signal Matrix with Asynchronous State Machine and Dual Supply

12 Clocking

12.1 GENERAL DESCRIPTION

The SLG46880/81 has three internal oscillators to support a variety of applications:

- Oscillator0 (2.048 kHz)
- Oscillator1 (2.048 MHz)
- Oscillator2 (25 MHz)

There are two divider stages for each oscillator that gives the user flexibility for introducing clock signals to connection matrix, as well as various other Macrocells. The pre-divider (first stage) for Oscillator allows the selection of /1, /2, /4 or /8 to divide down frequency from the fundamental. The second stage divider has an input of frequency from the pre-divider, and outputs one of eight different frequencies divided by /1, /2, /3, /4, /8, /12, /24 or /64 on Connection Matrix Input lines [27], [28], and [29]. Please see [Figure 82](#) for more details on the SLG46880/81 clock scheme.

Oscillator2 (25 MHz) has an additional function of 100 ns delayed startup, which can be enabled/disabled by register [525]. This function is recommended to use when analog blocks are used along with the Oscillator.

The Matrix Power-down/Force On function allows switching off or force on the oscillator using an external pin. The Matrix Power-down/Force On (Connection Matrix Output [72], [73], [74]) signal has the highest priority. The OSC operates according to the [Table 52](#).

Table 52: Oscillator Operation Mode Configuration Settings

POR	External Clock Selection	Signal From Connection Matrix	Register: Power-Down or Force On by Matrix Input	Register: Auto Power-On or Force On	OSC Enable Signal from CNT/DLY Macrocells	OSC Operation Mode
0	X	X	X	X	X	OFF
1	1	X	X	X	X	Internal OSC is OFF, logic is ON
1	0	1	0	X	X	OFF
1	0	1	1	X	X	ON
1	0	0	X	1	X	ON
1	0	0	X	0	CNT/DLY requires OSC	ON
1	0	0	X	0	CNT/DLY does not require OSC	OFF

Note: The OSC will run only when any macrocell that uses OSC is powered on.

GreenPAK Programmable Mixed-Signal Matrix with Asynchronous State Machine and Dual Supply

12.2 OSCILLATOR0 (2.048 KHZ)

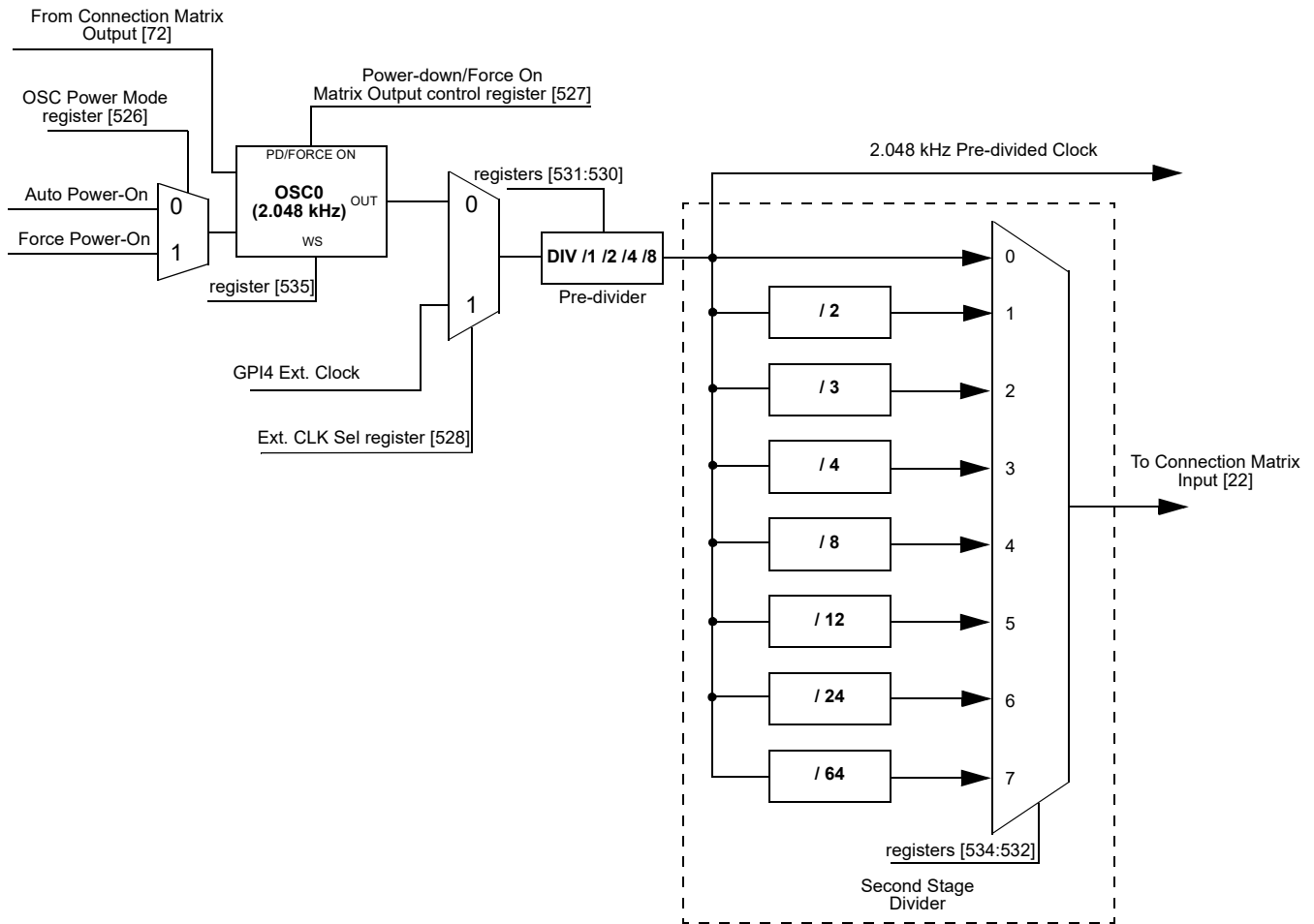

Figure 79: Oscillator0 Block Diagram

GreenPAK Programmable Mixed-Signal Matrix with Asynchronous State Machine and Dual Supply

12.3 OSCILLATOR1 (2.048 MHZ)

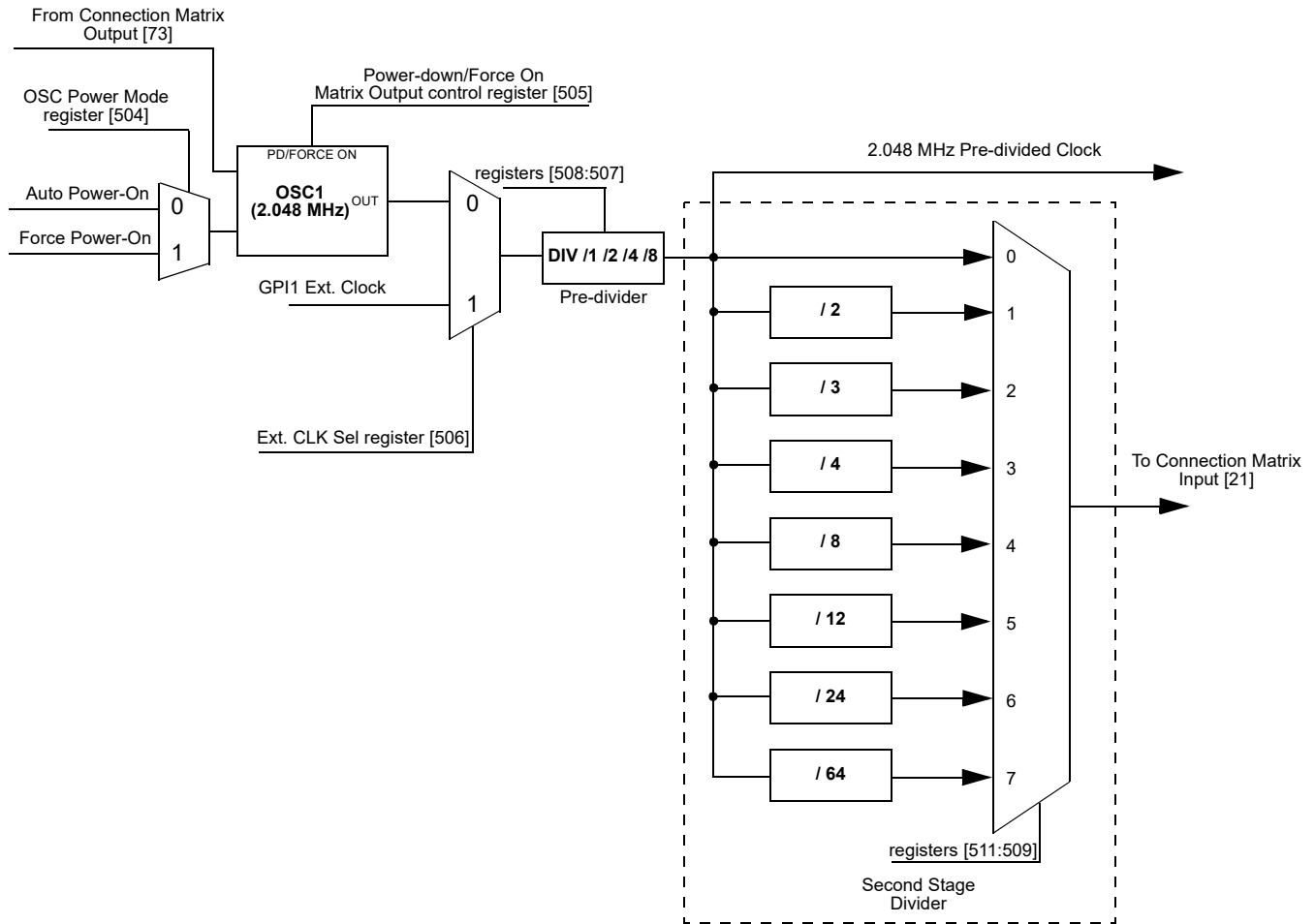

Figure 80: Oscillator1 Block Diagram

GreenPAK Programmable Mixed-Signal Matrix with Asynchronous State Machine and Dual Supply

12.4 OSCILLATOR2 (25 MHZ)

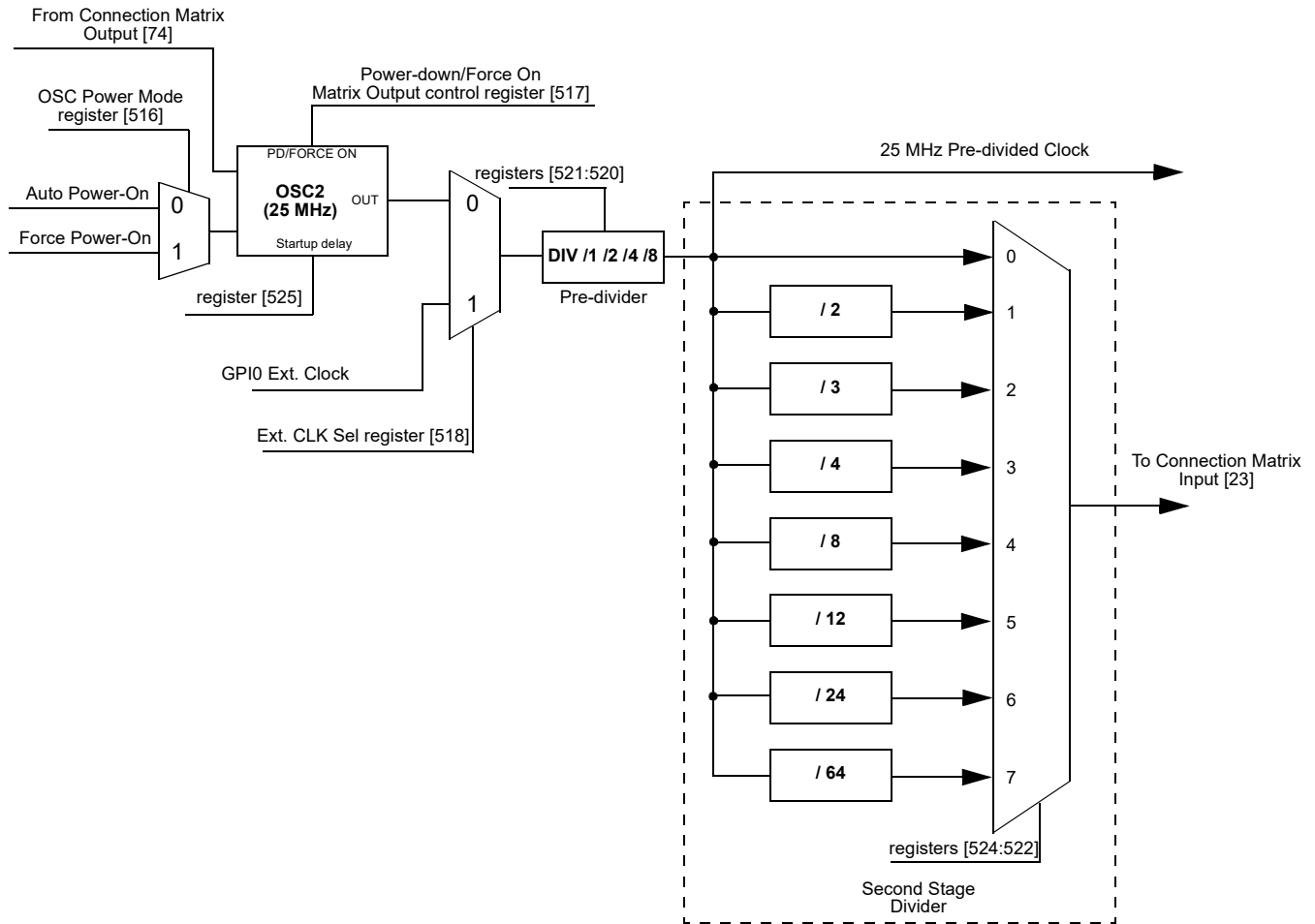

Figure 81: Oscillator2 Block Diagram

12.5 CLOCK SCHEME

Each CNT/DLY within Multi-Function macrocell has its own additional clock divider connected to oscillators pre-divider. Available dividers are:

- OSC0/1, OSC0/8, OSC0/64, OSC0/512, OSC0/4096, OSC0/32768, OSC0/262144
- OSC1/1, OSC1/8, OSC1/64, OSC1/512
- OSC2/1, OSC2/4

GreenPAK Programmable Mixed-Signal Matrix with Asynchronous State Machine and Dual Supply

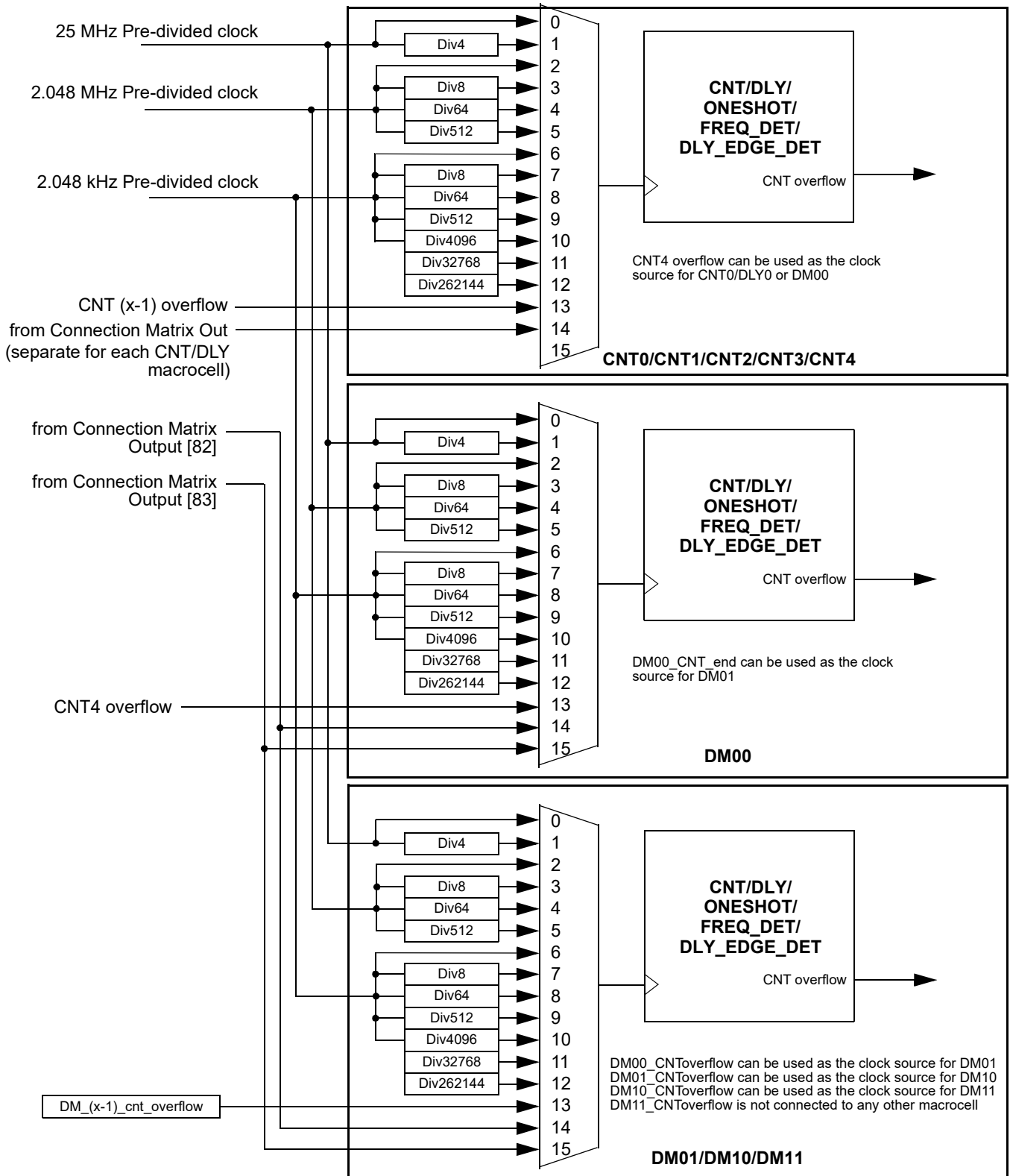

Figure 82: Clock Scheme

GreenPAK Programmable Mixed-Signal Matrix with Asynchronous State Machine and Dual Supply

12.6 CRYSTAL OSCILLATOR

The Crystal OSC provides high precision and stability of the output frequency. GPI5 and GPI4 are input and output, respectively, of an inverting amplifier which is configured for use as an On-chip Oscillator, as shown in Figure 84. Either a quartz crystal or a ceramic resonator may be used. C1 and C2 should always be equal for both crystals and resonators. The optimal value of the capacitors depends on the crystal or resonator in use, the amount of stray capacitance, and the electromagnetic noise of the environment. Refer to Table 53. For the ceramic resonators, the capacitor values given by the manufacturer should be used. It is possible to use an external clock source, it must be connected to GPI4. In this case no external components are required.

The Power-down Mode is paired with temperature sensor, Section 20. If it is enabled for Crystal OSC, it is not available for Temp Sensor and vice versa. However, it is possible to enable Power-down Mode for Crystal OSC and Temp Sensor simultaneously.

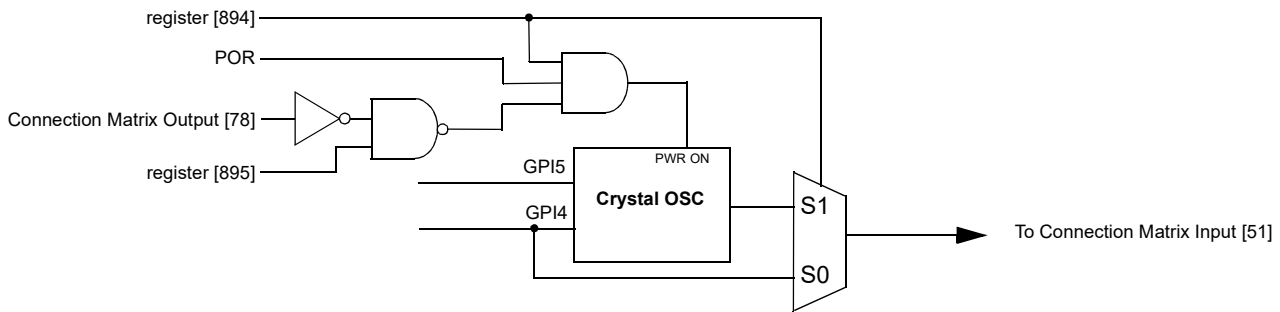

Figure 83: Crystal OSC Block Diagram

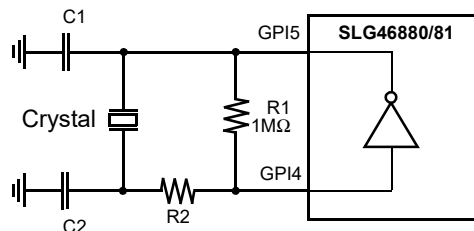

Figure 84: External Crystal Connection

Table 53: External Components Selection Table

f (MHz)	C1, C2	R2
5	33 pF	5 kΩ
10	22 pF	1 kΩ
15	15 pF	500 Ω
20	10 pF	270 Ω

12.7 EXTERNAL CLOCKING

The SLG46880/81 supports several ways to use an external, higher accuracy clock as a reference source for internal operations.

12.7.1 Crystal OSC Mode

When register [1136] is set to 1, an external crystal can be connected to GPI5 and GPI4 for supplying an accurate clock source. See Section 12.6. An external clocking signal on GPI4 can be used in place of the crystal. The high and low limits for crystal frequency that can be selected are 40 MHz and 32.75 kHz.

GreenPAK Programmable Mixed-Signal Matrix with Asynchronous State Machine and Dual Supply

12.7.2 GPI4 Source for Oscillator0 (2.048 kHz)

When register [528] is set to 1, an external clocking signal on GPI4 will be routed in place of the internal oscillator derived 2.048 kHz clock source. See [Figure 79](#). The high and low limits for external frequency are 0 MHz and 20 MHz.

12.7.3 GPI1 Source for Oscillator1 (2.048 kHz)

When register [506] is set to 1, an external clocking signal on GPI1 will be routed in place of the internal oscillator derived 2.048 MHz clock source. See [Figure 80](#). The high and low limits for external frequency are 0 MHz and 70 MHz.

12.7.4 GPI0 Source for Oscillator2 (25 MHz)

When register [518] is set to 1, an external clocking signal on GPI0 will be routed in place of the internal oscillator derived 25 MHz clock source. See [Figure 81](#). The high and low limits for external frequency are 0 MHz and 80 MHz.

12.8 OSCILLATORS POWER-ON DELAY

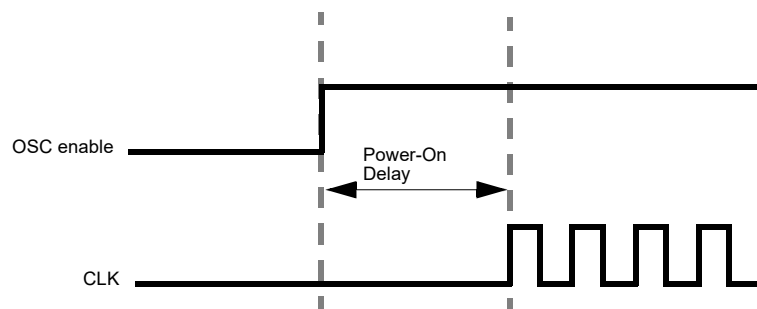

Figure 85: Oscillator Startup Diagram

Note 1 OSC power mode: “Auto Power-On”.

Note 2 “OSC enable” signal appears when any macrocell that uses OSC is powered on.

GreenPAK Programmable Mixed-Signal Matrix with Asynchronous State Machine and Dual Supply

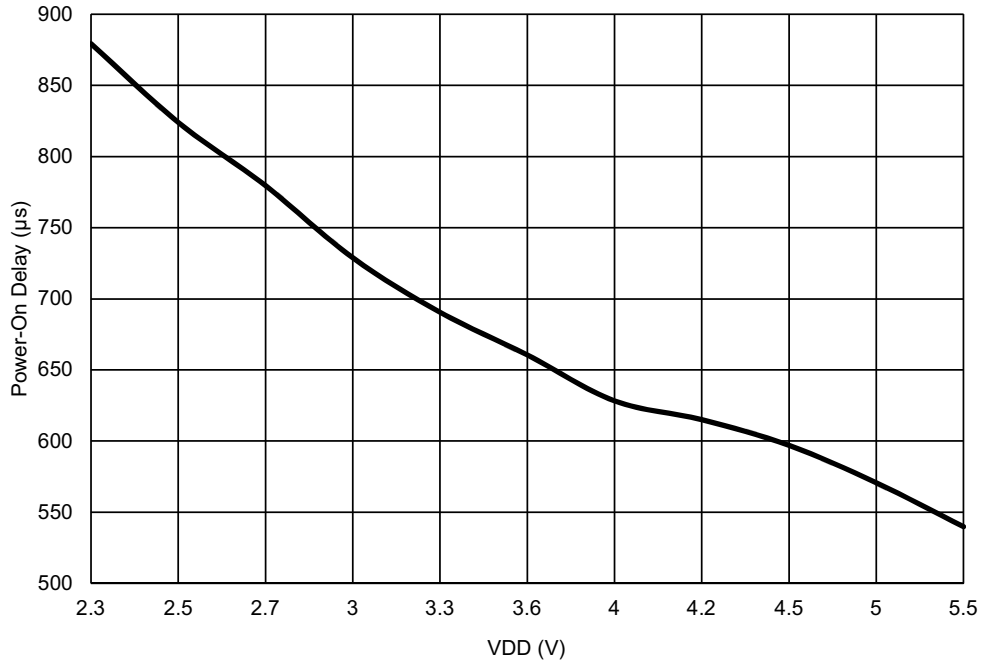

Figure 86: Oscillator0 Maximum Power-On Delay vs. V_{DD} at T = 25 °C, OSC0 = 2.048 kHz

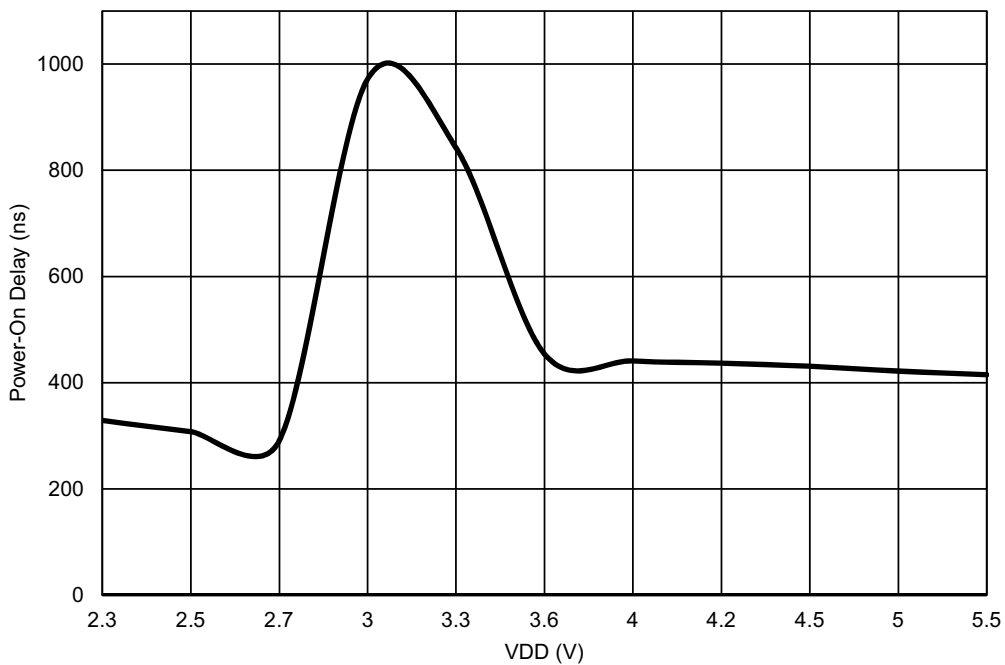

Figure 87: Oscillator1 Maximum Power-On Delay vs. V_{DD} at T = 25 °C, OSC1 = 2.048 MHz

GreenPAK Programmable Mixed-Signal Matrix with Asynchronous State Machine and Dual Supply

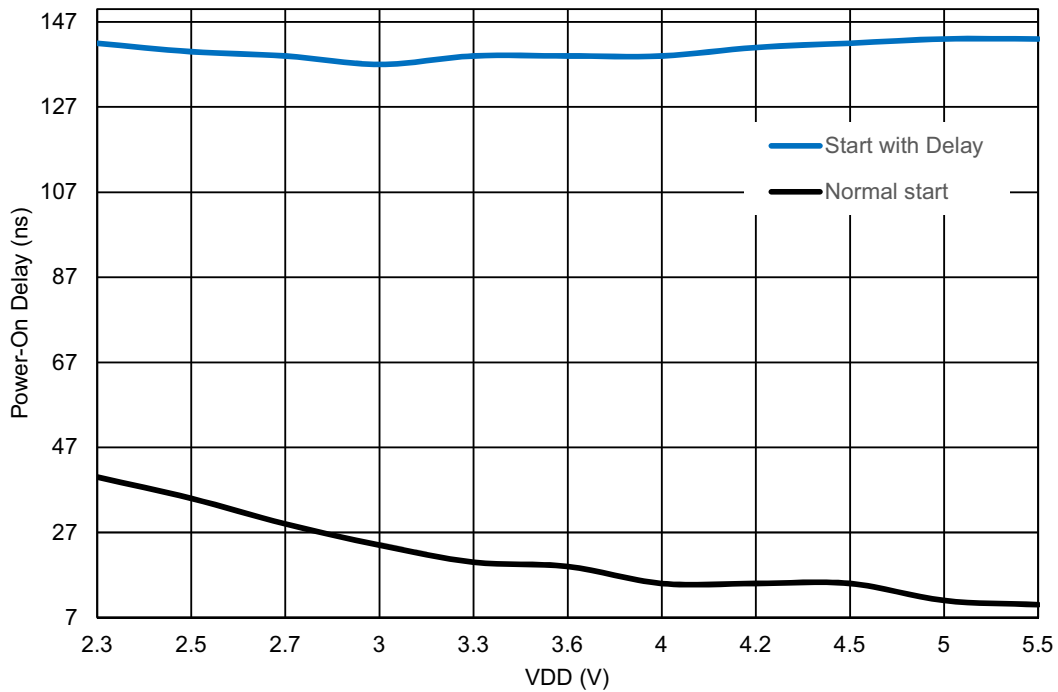

Figure 88: Oscillator2 Maximum Power-On Delay vs. V_{DD} at T = 25 °C, OSC2 = 25 MHz

12.9 OSCILLATORS ACCURACY

Note: OSC power setting: Force Power-On; Clock to matrix input - enable; Bandgap: turn on by register - enable.

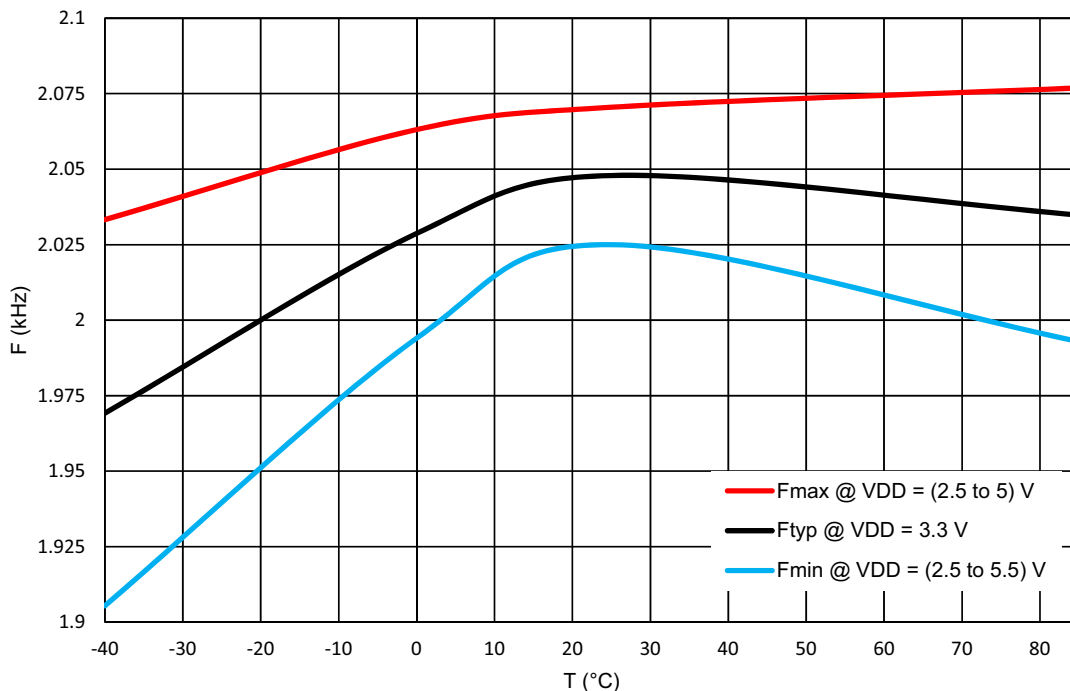

Figure 89: Oscillator0 Frequency vs. Temperature, OSC0 = 2.048 kHz

GreenPAK Programmable Mixed-Signal Matrix with Asynchronous State Machine and Dual Supply

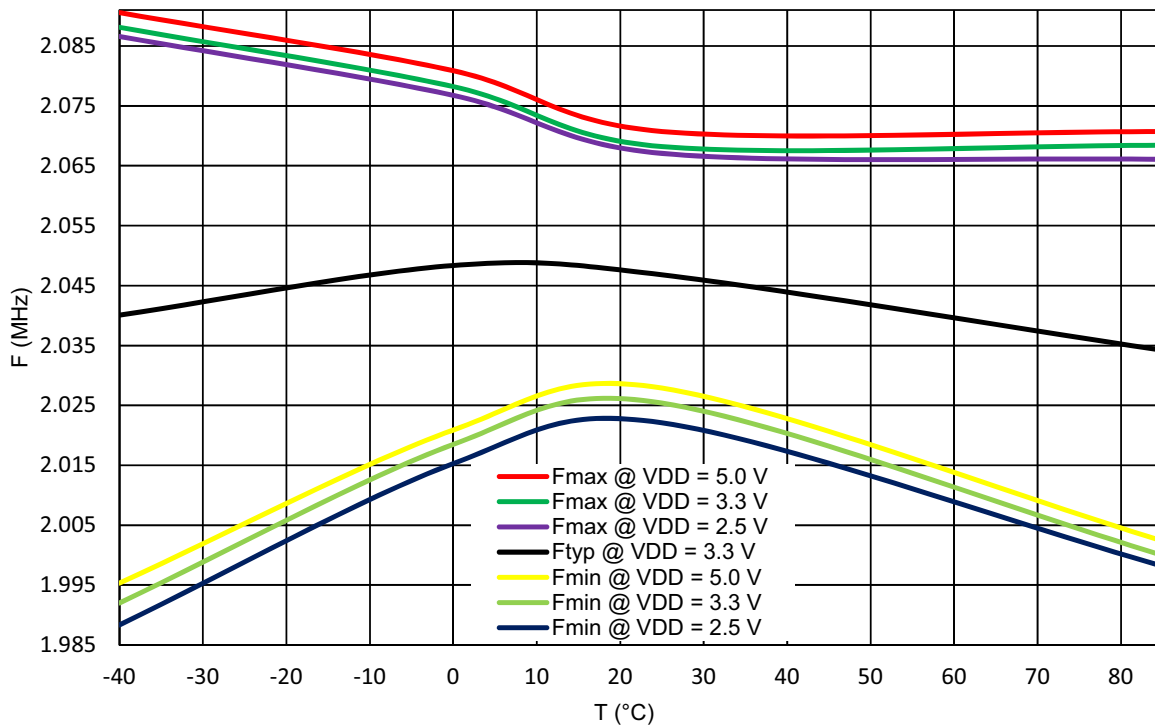

Figure 90: Oscillator1 Frequency vs. Temperature, OSC1 = 2.048 MHz

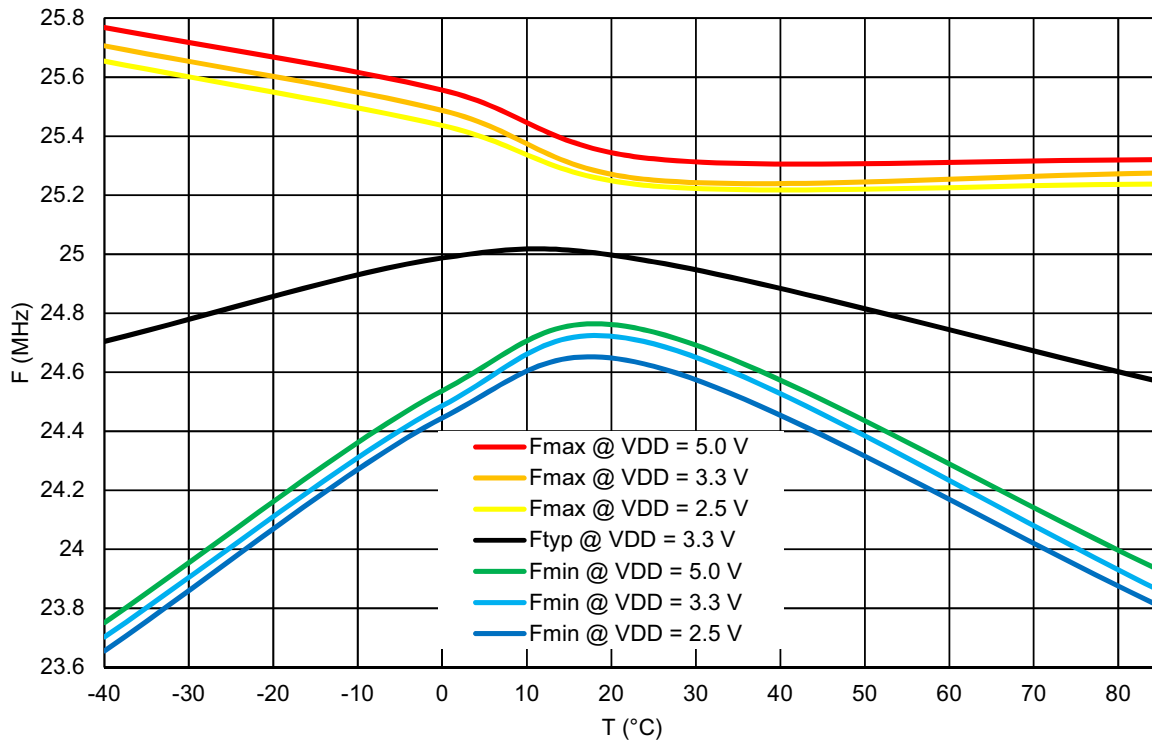

Figure 91: Oscillator2 Frequency vs. Temperature, OSC2 = 25 MHz

GreenPAK Programmable Mixed-Signal Matrix with Asynchronous State Machine and Dual Supply

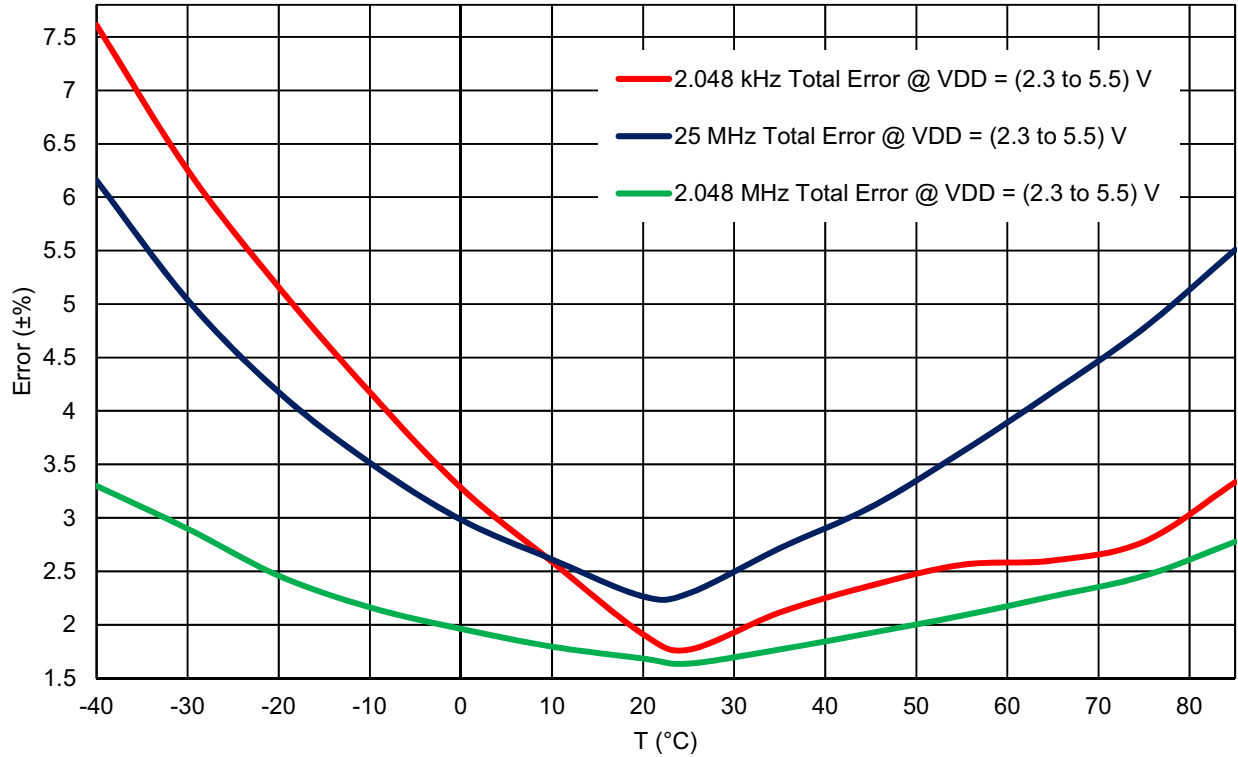

Figure 92: Oscillators Total Error vs. Temperature

Note: For more information see Section 3.6.

13 Power-On Reset

The SLG46880/81 has a Power-On Reset (POR) macrocell to ensure correct device initialization and operation of all macrocells in the device. The purpose of the POR circuit is to have consistent behavior and predictable results when the V_{DD} power is first ramping to the device, and also while the V_{DD} is falling during Power-down. To accomplish this goal, the POR drives a defined sequence of internal events that trigger changes to the states of different macrocells inside the device, and finally to the state of the IO pins.

13.1 GENERAL OPERATION

The SLG46880/81 is guaranteed to be powered down and non-operational when the V_{DD} voltage (voltage on V_{DD}) is less than Power-Off Threshold (see in [Table 3.4](#) and [Table 7](#)), but not less than -0.6 V. Another essential condition for the chip to be powered down is that no voltage higher (Note) than the V_{DD} voltage is applied to any other PIN. For example, if V_{DD} voltage is 0.3 V, applying a voltage higher than 0.3 V to any other PIN is incorrect, and can lead to incorrect or unexpected device behavior.

Note: There is a 0.6 V margin due to forward drop voltage of the ESD protection diodes.

To start the POR sequence in the SLG46880/81, the voltage applied on the V_{DD} should be higher than the Power-On threshold (Note). The full operational V_{DD} range for the SLG46880/81 is 2.3 V to 5.5 V. This means that the V_{DD} voltage must ramp up to the operational voltage value, but the POR sequence will start earlier, as soon as the V_{DD} voltage rises to the Power-On threshold. After the POR sequence has started, the SLG46880/81 will have a typical Startup Time (see in [Table 6](#) and [Table 7](#)) to go through all the steps in the sequence, and will be ready and completely operational after the POR sequence is complete.

Note: The Power-On threshold is defined in [Table 3.4](#) and [Table 7](#).

To power down the chip the, V_{DD} voltage should be lower than the operational and to guarantee that chip is powered down, it should be less than Power-Off Threshold.

All PINs are in high impedance state when the chip is powered down and while the POR sequence is taking place. The last step in the POR sequence releases the IO structures from the high impedance state, at which time the device is operational. The pin configuration at this point in time is defined by the design programmed into the chip. Also, as it was mentioned before, the voltage on PINs can't be bigger than the V_{DD} , this rule also applies to the case when the chip is powered on.

GreenPAK Programmable Mixed-Signal Matrix with Asynchronous State Machine and Dual Supply

13.2 POR SEQUENCE

The POR system generates a sequence of signals that enable certain macrocells. The sequence is shown in [Figure 93](#).

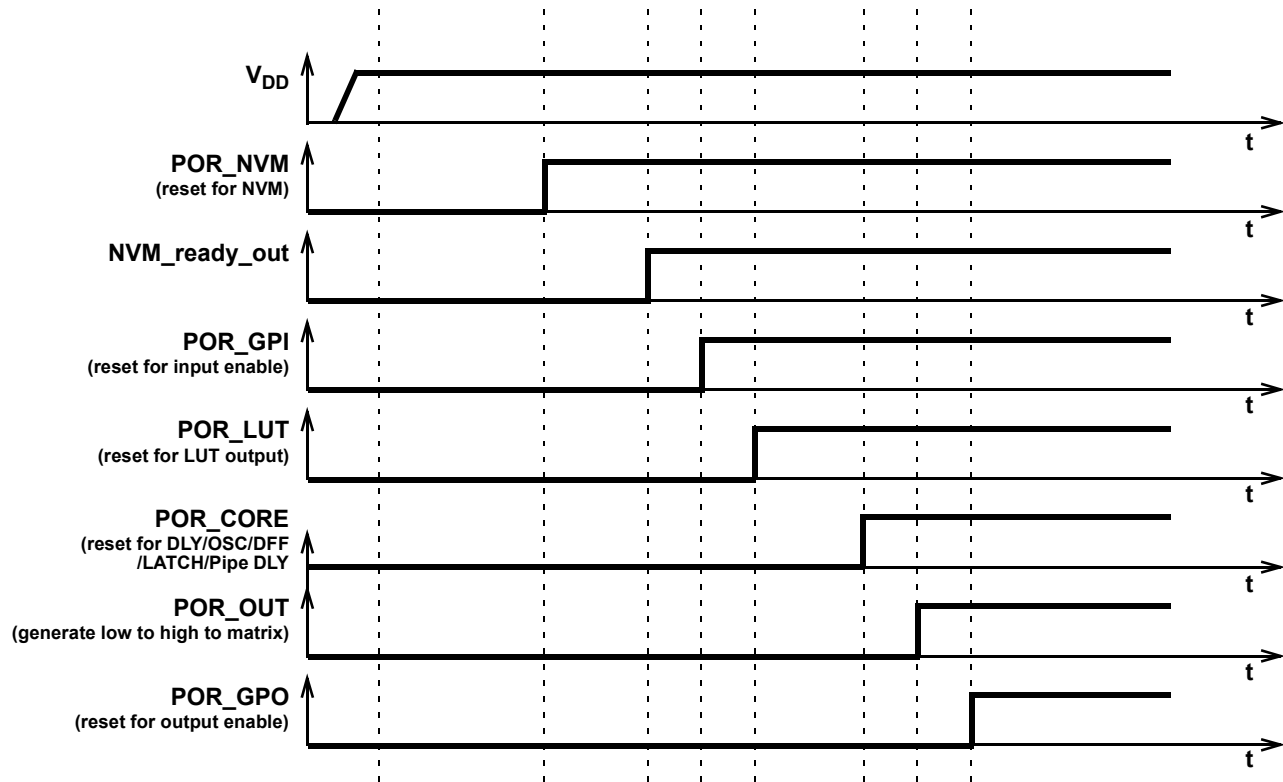

Figure 93: POR Sequence

As can be seen from [Figure 93](#), after the V_{DD} has started ramping up and crossed the Power-On threshold, first, the on-chip NVM memory is reset. Next, the chip reads the data from NVM, and transfers this information to a CMOS LATCH that serves to configure each macrocell, and the Connection Matrix which routes signals between macrocells. The third stage causes the reset of the input pins, and then to enable them. After that, the LUTs are reset and become active. After LUTs, the Delay cells, OSCs, DFFs, LATCHES, and Pipe Delay are initialized. Only after all macrocells are initialized, internal POR signal (POR macrocell output) goes from LOW to HIGH (POR_OUT in [Figure 93](#)). The last portion of the device to be initialized is the output pins, which transition from high impedance to active at this point.

The typical time that takes to complete the POR sequence varies by device type in the GreenPAK family. It also depends on many environmental factors, such as: slew rate, V_{DD} value, temperature, and even will vary from chip to chip (process influence).

13.3 MACROCELLS OUTPUT STATES DURING POR SEQUENCE

To have a full picture of SLG46880/81 operation during powering and POR sequence, refer to [Figure 94](#), which describes the macrocell output states during the POR sequence.

First, before the NVM has been reset, all macrocells have their output set to logic LOW (except the output pins which are in high impedance state). On the next step, some of the macrocells start initialization: input pins output state becomes LOW; LUTs also output LOW. After that input pins are enabled. Next, only LUTs are configured. Then, all other macrocells are initialized. After

GreenPAK Programmable Mixed-Signal Matrix with Asynchronous State Machine and Dual Supply

macrocells are initialized, internal POR matrix signal switches from LOW to HIGH. The last are output pins that become active and determined by the input signals.

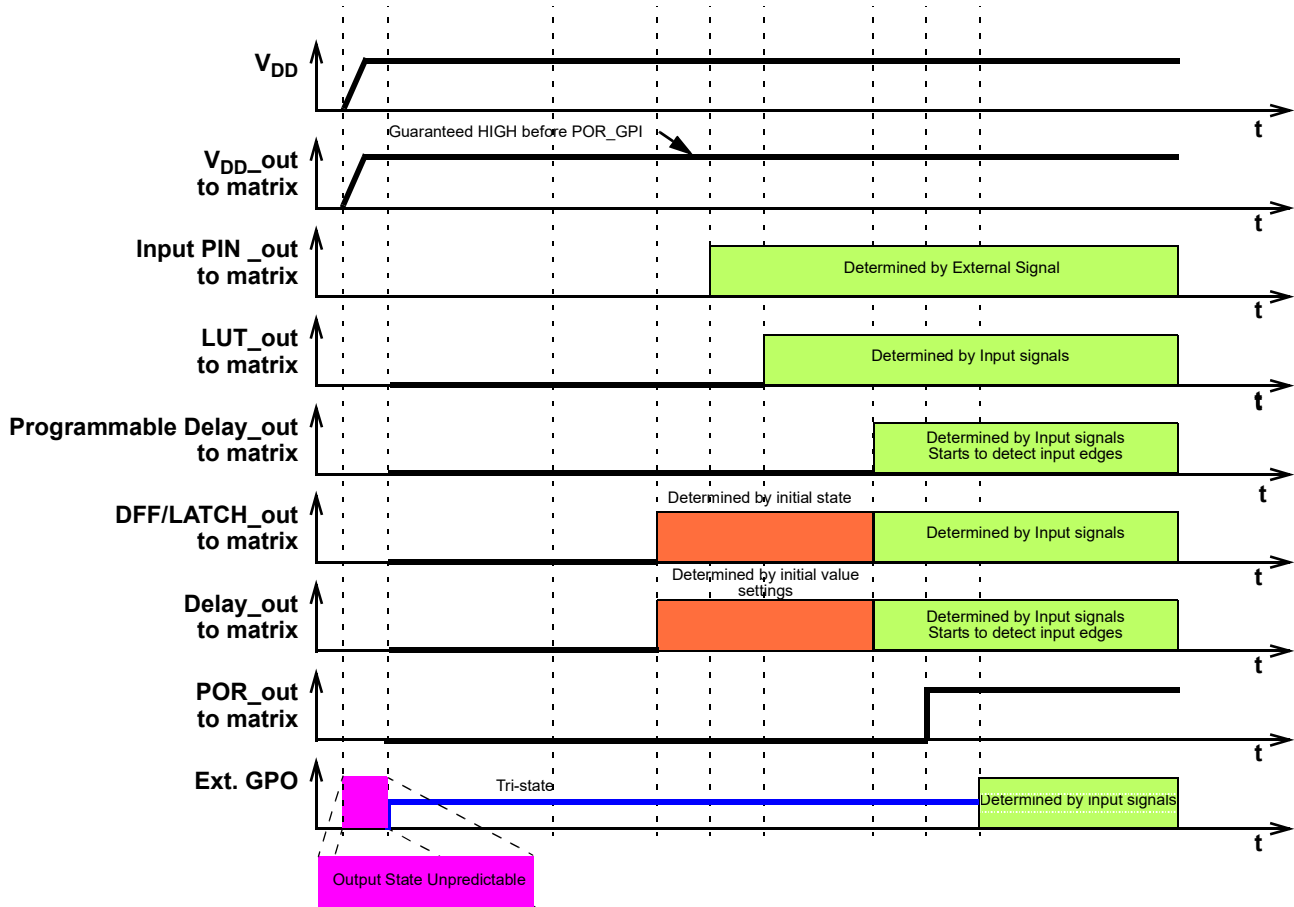

Figure 94: Internal Macrocell States during POR Sequence

13.3.1 Initialization

All internal macrocells by default have initial low level. Starting from indicated power-up time of 1.64 V to 2.11 V, macrocells in SLG46880/81 are powered on while forced to the reset state. All outputs are in Hi-Z and chip starts loading data from NVM. Then the reset signal is released for internal macrocells and they start to initialize according to the following sequence:

1. Input pins, Pull-up/down.
2. LUTs.
3. DFFs, Delays/Counters, Pipe Delay, OSCs, ACMPs.
4. POR output to matrix.
5. Output pin corresponds to the internal logic.

The Vref output pin driving signal can precede POR output signal going high by 3 μs to 5 μs. The POR signal going high indicates the mentioned power-up sequence is complete.

Note: The maximum voltage applied to any pin should not be higher than the V_{DD} level. There are ESD Diodes between pin → V_{DD} and pin → GND on each pin. Exceeding V_{DD} results in leakage current on the input pin, and V_{DD} will be pulled up, following the voltage on the input pin.

13.3.2 Power-Down

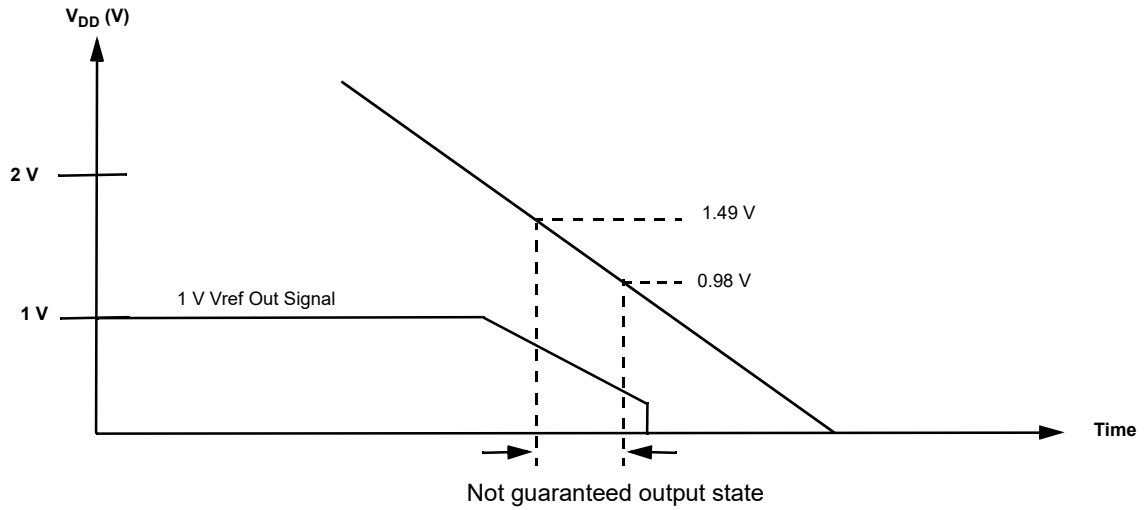

Figure 95: Power-Down

During powerdown, macrocells in SLG46880/81 are powered off after V_{DD} falling down below Power-Off Threshold. Please note that during a slow rampdown, outputs can possibly switch state.

GreenPAK Programmable Mixed-Signal Matrix with Asynchronous State Machine and Dual Supply

14 Asynchronous State Machine Subsystem

14.1 ASM SUBSYSTEM OVERVIEW

The Asynchronous State Machine (ASM) Subsystem is designed to allow the user to create state machines with between 2 to 12 states. The user has flexibility to define the available states, the available state transitions, and the input signals (a, b, c ...) that will cause transitions from one state to another state, as shown in [Figure 96](#).

The ASM Subsystem can persist in 1 of 12 states at any given time and the ASM Current State can be read via I²C. See [Section 19.6.2](#) for details.

The ASM Subsystem includes several discrete macrocells, including the ASM macrocell, four Dynamic Memory (DMx_x) macrocells, three Matrix Interface (MIx) macrocells, and one f(1) Computation Macrocell. These macrocells are designed to work as a system for building user defined state machines. More information on each of these various macrocells can be found in the following chapters:

- ASM Macrocell – [Section 15](#).
- Dynamic Memory (DM) Macrocells – [Section 16](#).
- f(1) Computation Macrocell – [Section 17](#).
- Matrix Interface (MI) Macrocells [Section 18](#).

The ASM Subsystem has a total of 25 digital input signal lines, as shown in [Figure 97](#), which all come from the Connection Matrix outputs. Of these 25 digital input signals, 3 are user selectable inputs going directly from the Connection Matrix to the three Matrix Interface (MI) macrocells. There are a total of 16 input signals that go to the DMx_x macrocell, four per macrocell. There is 1 ASM_nReset input that is for driving a state transition in both the ASM macrocell and the f(1) Computation Macrocell to an Initial/Reset state. It is possible to use one macrocell only (MI or DM) for state to state transitions. There are 4 digital input signals coming from the Connection Matrix to the f(1) Computation Macrocell. There is also 1 dedicated Interrupt input signal to the f(1) Computation Macrocell that will halt any active operations and transfer control back to the ASM macrocell.

There are a total of 8 analog inputs coming from various pins which can be muxed into the positive input for the f(1) Analog Comparator inside the f(1) Computation Macrocell. The f(1) Analog Comparator can be re-programmed for analog input source and negative input reference settings. The user selections for both positive input signal and negative reference are included as part of the information stored in the f(1) Command Register Table. This allows the user to make different analog measurements that are state dependent in their analog sources and reference settings.

The ASM Subsystem has a total of 21 digital output signal lines, as shown in [Figure 97](#). There are a total of 4 output signals which go to the Connections Matrix inputs, and from there can be routed to other internal macrocells or pins. The 4 outputs are user defined for each of the possible 12 states. There are a total of 8 output signals which go directly to the 8 GPOs. The 8 outputs are user defined for each of the possible 12 states. Each of the three macrocells, DM0_0, DM0_1 and f(1) have three output signals that go to the Connection Matrix.

In using this macrocell, the user must take into consideration the critical timing required on all input and output signals. The timing waveforms and timing specifications for this macrocell are all measured relative to the input signals (which come into the macrocell on the Connection Matrix outputs) and on the outputs from the macrocell (which are direct connections to Connection Matrix inputs). The user must consider any delays from other logic and internal chip connections, including IO delays, to insure that signals are properly processed, and state transitions are deterministic.

It is also important to note that the timing for the ASM Subsystem will change based on changes in temperature and system voltage. The user design that implements a state machine function must take into consideration, and be tolerant of, this variation

The GPAK Designer development tools support user designs for the ASM Subsystem at both the physical level and logic level. [Figure 96](#) is a representation of the user design at the logical level, and [Figure 97](#) shows the physical resources inside the various macrocells in the ASM Subsystem. To best utilize this subsystem, the user must develop a logical representation of their desired state machine, as well as a physical mapping of the input and outputs required for the desired functionality.

GreenPAK Programmable Mixed-Signal Matrix with Asynchronous State Machine and Dual Supply

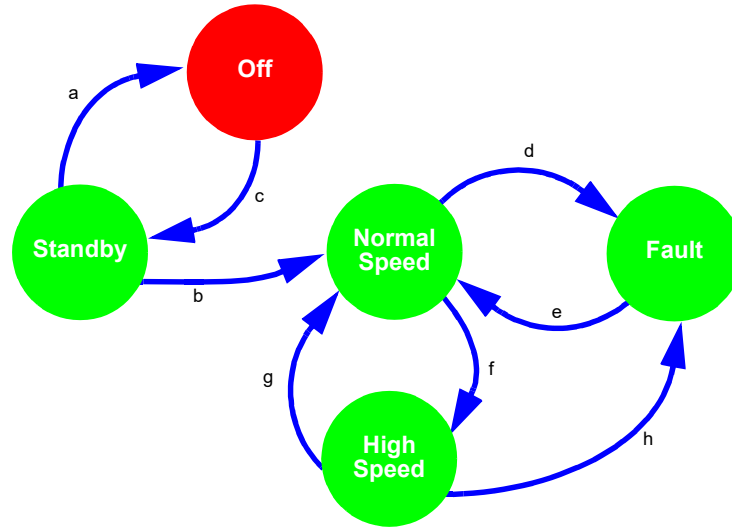

Figure 96: Asynchronous State Machine State Transitions

GreenPAK Programmable Mixed-Signal Matrix with Asynchronous State Machine and Dual Supply

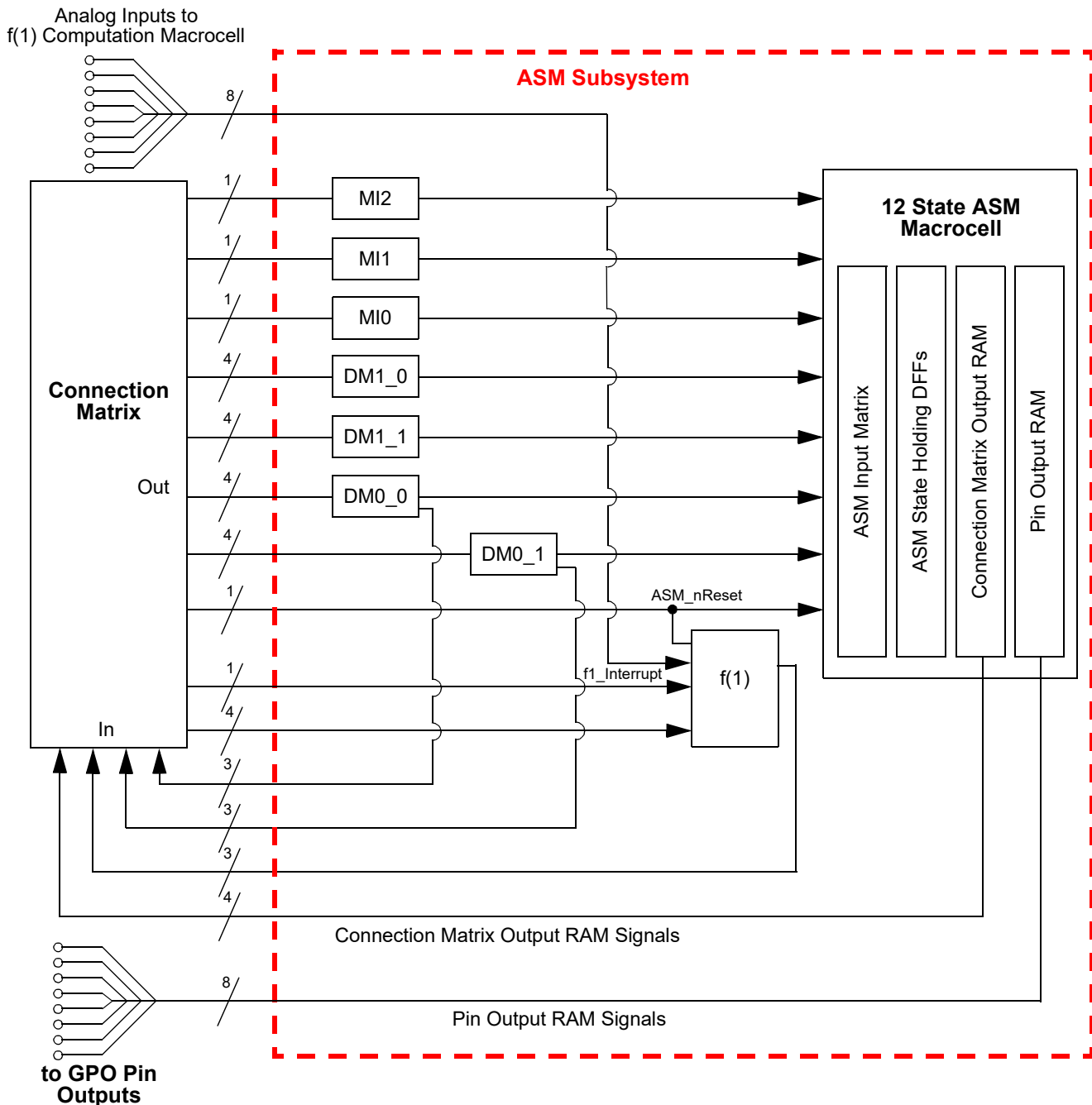

Figure 97: Connection Matrix to ASM Subsystem

14.2 ASM SUBSYSTEM INPUT SIGNALS

The ASM Subsystem has a total of 25 digital input signal lines, as shown in Figure 98, which all come from the Connection Matrix outputs. Of these 25 input signals, 3 are user selectable inputs going directly from the Connection Matrix to the three Matrix Interface (MI) macrocells. There are a total of 16 input signals that go to the DM_x macrocell, four per macrocell. There is 1 ASM_nReset input that is for driving a state transition in both the ASM macrocell and the f(1) Computation Macrocell to an Initial/Reset state. There are 4 digital input signals coming from the Connection Matrix to the f(1) Computation Macrocell. There is also 1 dedicated Interrupt input to the f(1) Computation Macrocell that will halt any active operations and transfer control back to the ASM macrocell. Each of the 25 input signals are level sensitive.

GreenPAK Programmable Mixed-Signal Matrix with Asynchronous State Machine and Dual Supply

There are a total of 16 digital input signals to the ASM Subsystem which are inputs directly to the DM macrocells. These 16 signals are shown in [Figure 98](#), highlighted in blue. While there are 4 input signals coming from the Connection Matrix and going to each DMx_x macrocell, there is only 1 output signal from each of these macrocells, which goes directly to the ASM macrocell. There are also 3 signal lines that come directly from the Connection Matrix and go to the three Matrix Interface (MI) macrocells which can drive state transitions. These signals are shown in [Figure 98](#), highlighted in green. This sets an upper bound on the number of transitions that the user can select going **out of** a particular state to be 7, shown in [Figure 99](#). There is no limitation on the number of unique transitions that can be supported going into a particular state, the user can select to have transitions going from a state to all other states, shown in [Figure 100](#). Each of these input signals to the ASM macrocell is level sensitive, and active high. A high level input will trigger a state transition.

There are a total of 8 analog inputs coming from various pins which can be muxed into the positive input for the f(1) Analog Comparator inside the f(1) Computation Macrocell. These 8 signals are shown in [Figure 98](#), highlighted in pink. The f(1) Analog Comparator can be re-programmed for analog input source and negative input reference settings. The user selections for both positive input signal and negative reference are included as part of the information stored in the f(1) Command Register Table. This allows the user to make different analog measurements that are state dependent in their analog sources and reference settings.

Also, there are 4 digital inputs that can be connected with any Connection Matrix output by the f(1) Computational Macrocell commands. These 4 signals are shown in highlighted in light blue.

The ASM macrocell also has a ASM_nReset input. This input to the ASM macrocell is level sensitive and active low. This signal is shown in [Figure 98](#), highlighted in yellow. An active signal on this input will drive an immediate state transition to the user-defined Initial/Reset state. The user can choose which state within the ASM Editor inside GPAK Designer will be the reset state.

There is also 1 dedicated f1_Interrupt input to the f(1) Computation Macrocell that will halt any active operations and transfer control back to the ASM macrocell. This signal is shown in [Figure 98](#), also highlighted in yellow.

GreenPAK Programmable Mixed-Signal Matrix with Asynchronous State Machine and Dual Supply

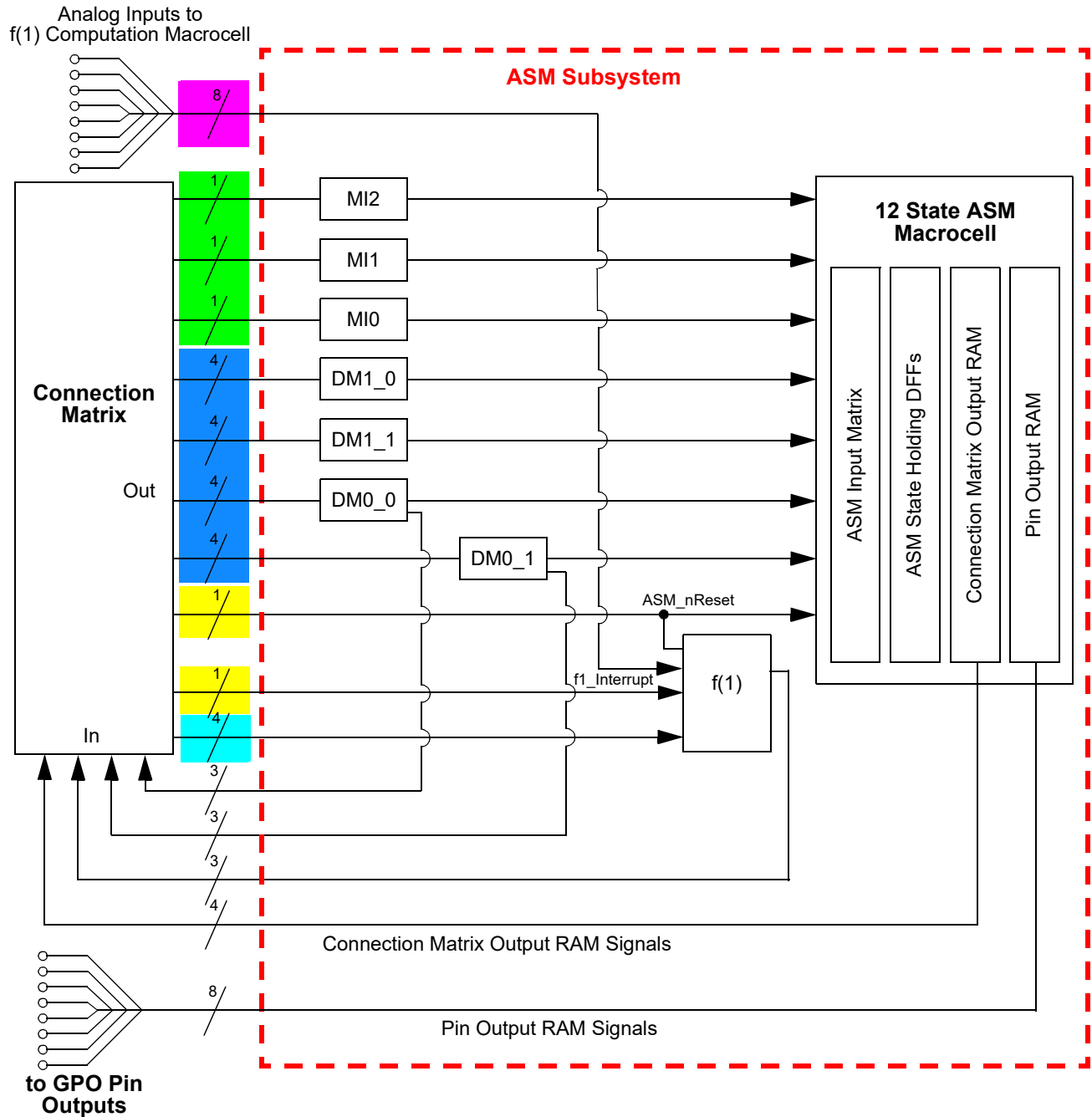

Figure 98: ASM Subsystem Input Signals

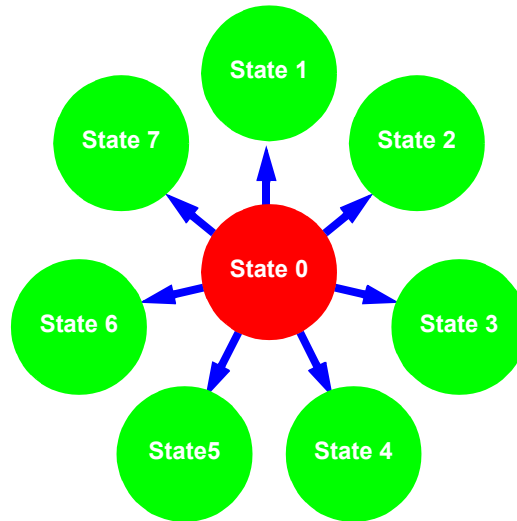

Figure 99: Maximum 7 State Transitions out of a Given State

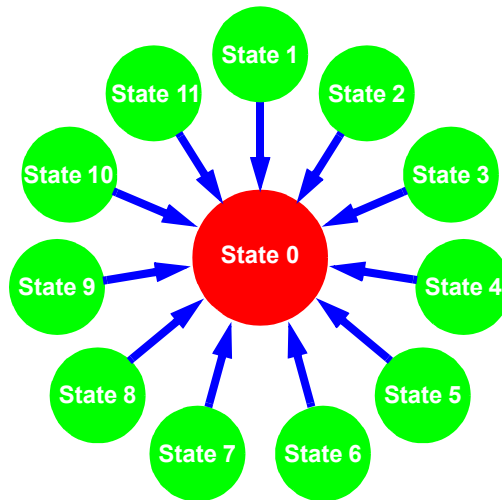

Figure 100: Maximum 11 State Transitions into Given State

14.3 ASM SUBSYSTEM OUTPUT SIGNALS

The ASM subsystem has a total of 21 output signal lines, as shown in [Figure 101](#).

There are a total of 4 output signals from the ASM macrocell which go to the Connections Matrix inputs and from there can be routed to other internal macrocells or pins. These signals are shown in [Figure 101](#), highlighted in green. The 4 outputs are user defined for each of the possible 12 states. The user selection for the output states is held in the Connection Matrix Output RAM.

There are a total of 8 output signals from the ASM macrocell which go directly to the 8 GPOs. These signals are shown in [Figure 101](#), highlighted in blue. The 8 outputs are user defined for each of the possible 12 states. The user selection for the output states is held in the Pin Output RAM. Each of these GPOs has a single selection bit which defines the GPO input source as either the ASM Output RAM signal or the Connection Matrix signal.

GreenPAK Programmable Mixed-Signal Matrix with Asynchronous State Machine and Dual Supply

Two of the Dynamic Memory macrocells, DM0_0 and DM0_1, can be used as either a resource for generating input signals for driving state transitions in the ASM macrocell, or to generate signals for use in other parts of the user design. When used to generate signals for purposes other than ASM state transitions, each of these macrocells has three output signals that go to the Connection Matrix, and from there can be routed to other internal macrocells or pins. Each of these macrocells has a total of 3 output signals of this type. These signals are shown in Figure 101, highlighted in yellow.

The f(1) Computation Macrocell has 3 output signals that go to the Connection Matrix, and from there can be routed to other internal macrocells or pins. These signals are shown in Figure 101, highlighted in pink.

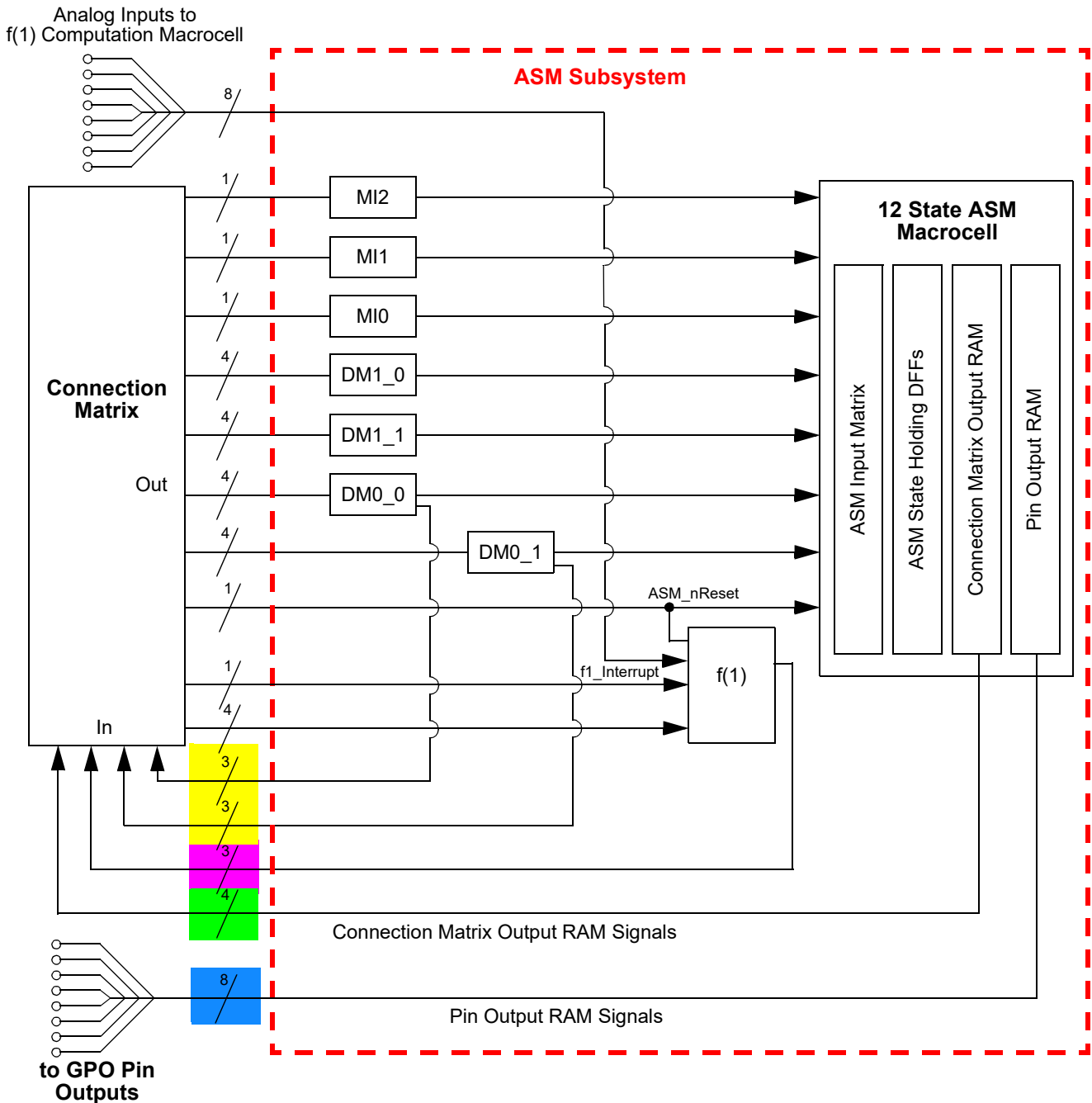

Figure 101: ASM Subsystem Input Signals

GreenPAK Programmable Mixed-Signal Matrix with Asynchronous State Machine and Dual Supply

14.4 BASIC ASM_SUBSYSTEM TIMING

The basic state transition timing from input on one of 19 state transition input lines (4 going into each DMx_x and 3 from Connection Matrix going directly to the ASM macrocell) to the time when the 4 Connection Matrix Output RAM signals and 8 Pin Output RAM signals change is shown in [Figure 102](#) and [Figure 103](#). The time from a valid input signal to the time that there is a valid change of state, and valid signals on the 4 Connection Matrix Output RAM signals and 8 Pin Output RAM signals is State Machine Output Delay Time ($T_{st_out_delay}$).

At the point in time that the Connection Matrix Output RAM signals and Pin Output RAM signals are changing, the f(1) Computation Macrocell is prepared for executing commands coded for the new state, if the user has coded commands to execute. Based on the chosen commands, the f(1) Computation Macrocell outputs can change a number of times before the f(1) finishes for the new state. The ASM Subsystem will not be ready for the next state transition until the f(1) Computation Macrocell has completed the commands for the new state, or until it is reset by asserting the f1_Interrupt input from the Connection Matrix. The period of time between the input on one of the 7 inputs to the ASM macrocell and the ASM subsystem being ready for the next state transition is State Machine Sequential Delay Time ($T_{st_sequential_delay}$).

From the input on one of 19 state transition input lines, there is a delay before the outputs are latched from the DM0_0 and DM0_1 macrocells, noted as DM Connection Matrix Output Delay Time ($T_{st_dmlatch_delay}$).

During state transitions, there will be no change in output levels on other states than the one state going active→inactive and the other state going inactive→active

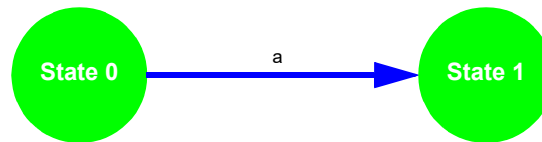

Figure 102: State Transition

GreenPAK Programmable Mixed-Signal Matrix with Asynchronous State Machine and Dual Supply

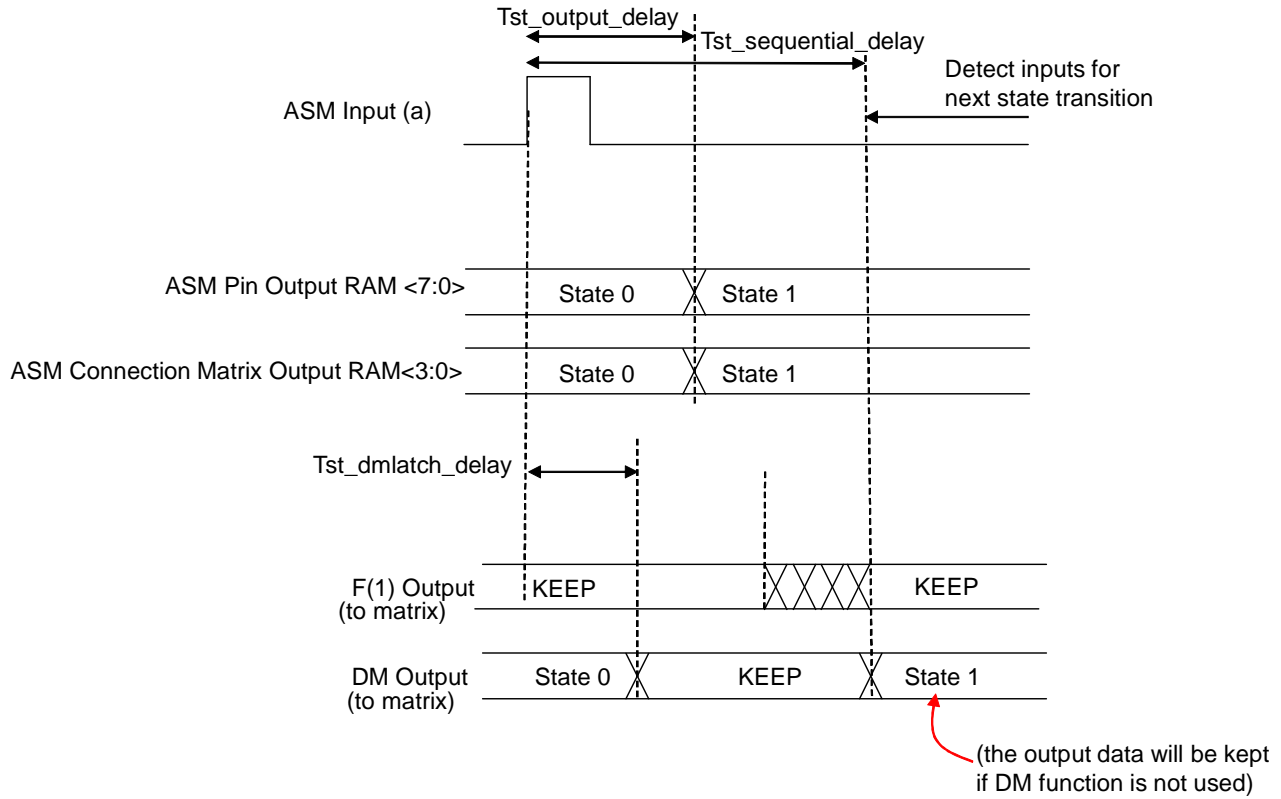

Figure 103: State Transition Timing

14.5 ASM POWER CONSIDERATIONS

A benefit of the asynchronous nature of this macrocell is that it will consume power only during state transitions. Shown in Figure 104 and Figure 105, the current consumption of the macrocell will be a fraction of a μA between state transitions, and will rise only during state transitions. This is assuming that the DLY/CNT inside each DMx_x macrocells are also in-active. See Table 10 to find average current during state transitions.

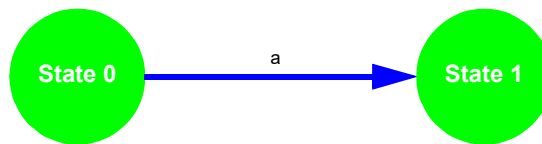

Figure 104: State Transition

GreenPAK Programmable Mixed-Signal Matrix with Asynchronous State Machine and Dual Supply

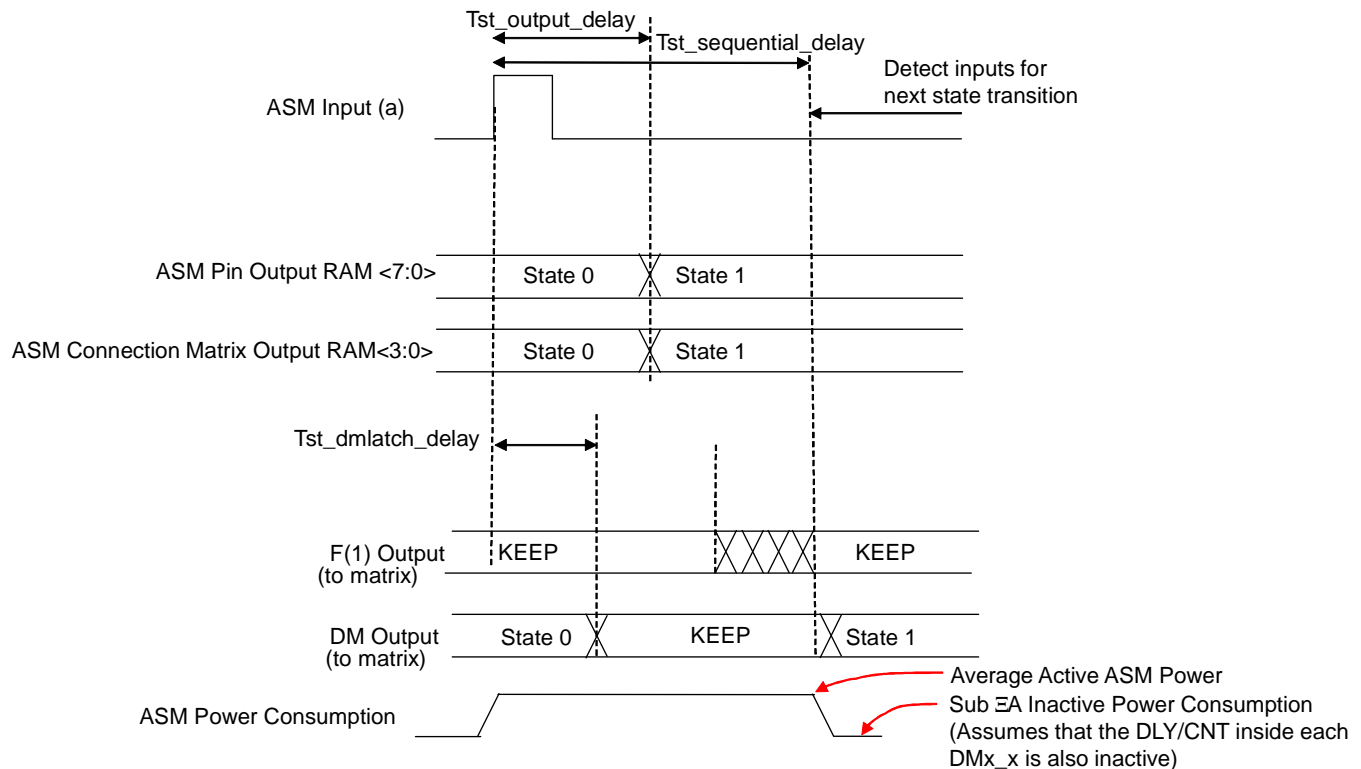

Figure 105: State Transition Timing and Power Consumption

14.6 ASYNCHRONOUS STATE MACHINES VS. SYNCHRONOUS STATE MACHINES

It is important to note that this macrocell is designed for asynchronous operation, which means the following:

1. No clock source is needed, it reacts only to input signals.
2. The input signals do not have to be synchronized to each other, the macrocell will react to the earliest valid signal for state transition.
3. This macrocell does not have traditional set-up and hold time specifications which are related to incoming clock, as this macrocell has no clock source.
4. The macrocell only consumes power while in state transition.

14.7 ASM SPECIAL CASE TIMING CONSIDERATIONS

14.7.1 State Transition Pulse Input Timing

All inputs to the ASM macrocell are level sensitive. If the input to the state machine macrocell for a state transition is a pulse, there is a minimum pulse width on the input to the state machine macrocell (as measured at the matrix input to the macrocell) which is guaranteed to result in a state transition shown in Figure 106 and Figure 107. This pulse width is defined by the State Machine Input Pulse Acceptance Time (T_{st_pulse}). If a pulse width that is shorter than T_{st_pulse} is input to the state machine macrocell, it is indeterminate whether the state transition will happen or not. If a pulse that is rejected (invalid due to the pulse

GreenPAK Programmable Mixed-Signal Matrix with Asynchronous State Machine and Dual Supply

width being narrower than the guaranteed minimum of T_{st_pulse}), this will not stop a valid pulse on another state transition input that does meet minimum pulse width.

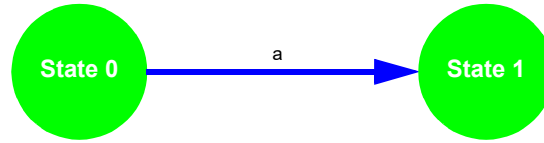

Figure 106: State Transition

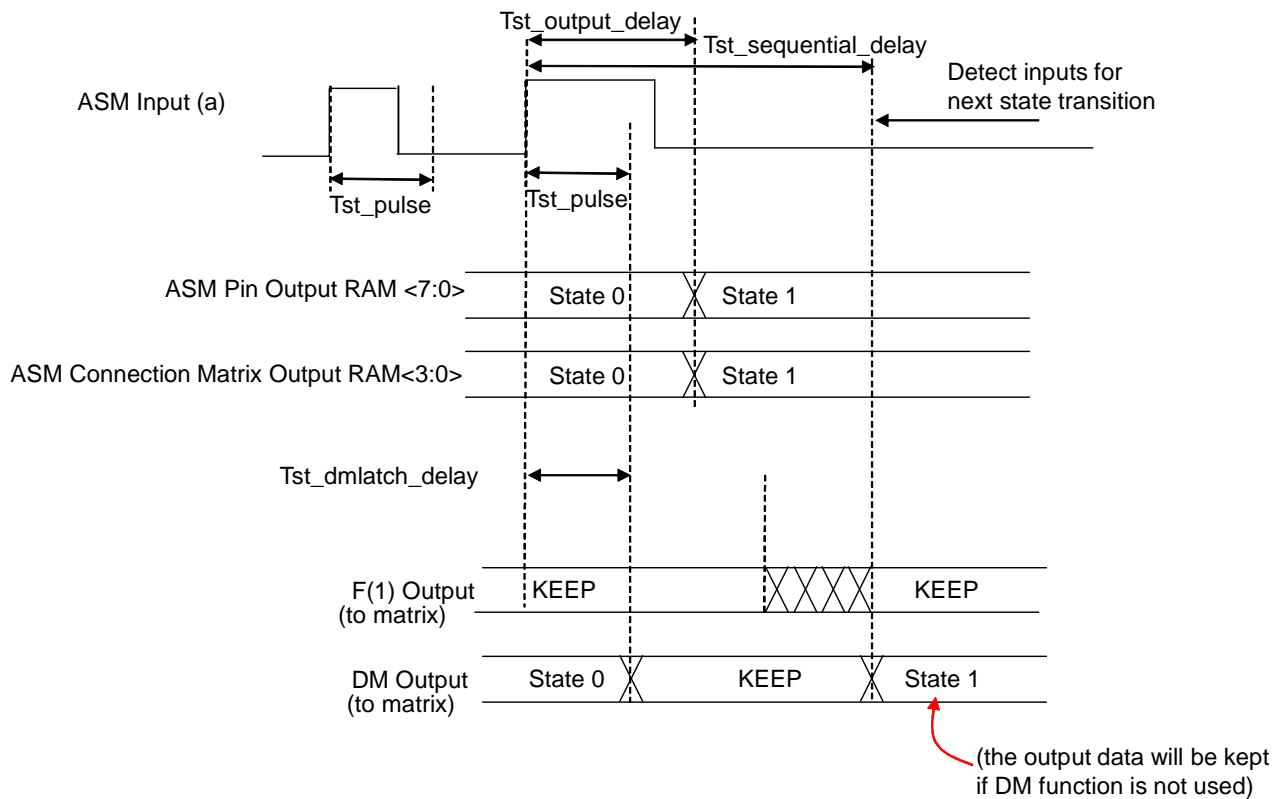

Figure 107: State Transition Pulse Input Timing

14.7.2 State Transition Competing Input Timing

There will be situations where two input signals can be valid inputs that will drive two different state transitions from a given state. In that sense, the two signals are "competing" (signals a and b in Figure 108), and the signal that arrives sooner should drive the state transition that will "win", or drive the state transition. If one signal arrives T_{st_comp} before the other one, it is guaranteed to win, and the state transition that it codes for will be taken, as shown in Figure 109. If the two signals arrive within T_{st_comp} of each

GreenPAK Programmable Mixed-Signal Matrix with Asynchronous State Machine and Dual Supply

other, it will be indeterminate which state transition will win, but one of the transitions will take place as long as the winning signal satisfies the pulse width criteria described in the paragraph above, as shown in Figure 110.

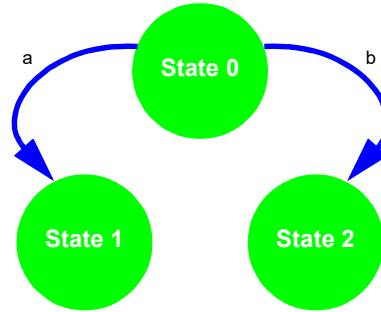

Figure 108: State Transition - Competing Inputs

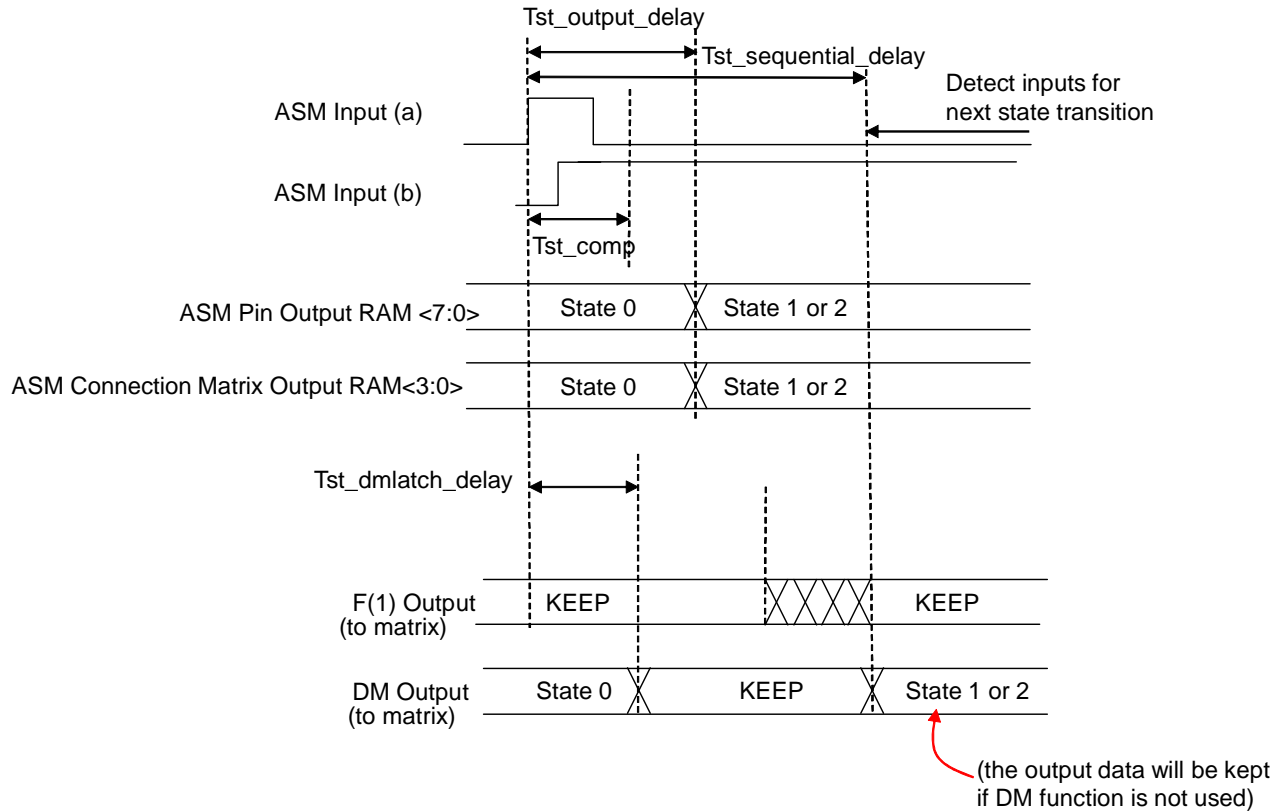

Figure 109: State Transition Timing - Competing Inputs Indeterminate

GreenPAK Programmable Mixed-Signal Matrix with Asynchronous State Machine and Dual Supply

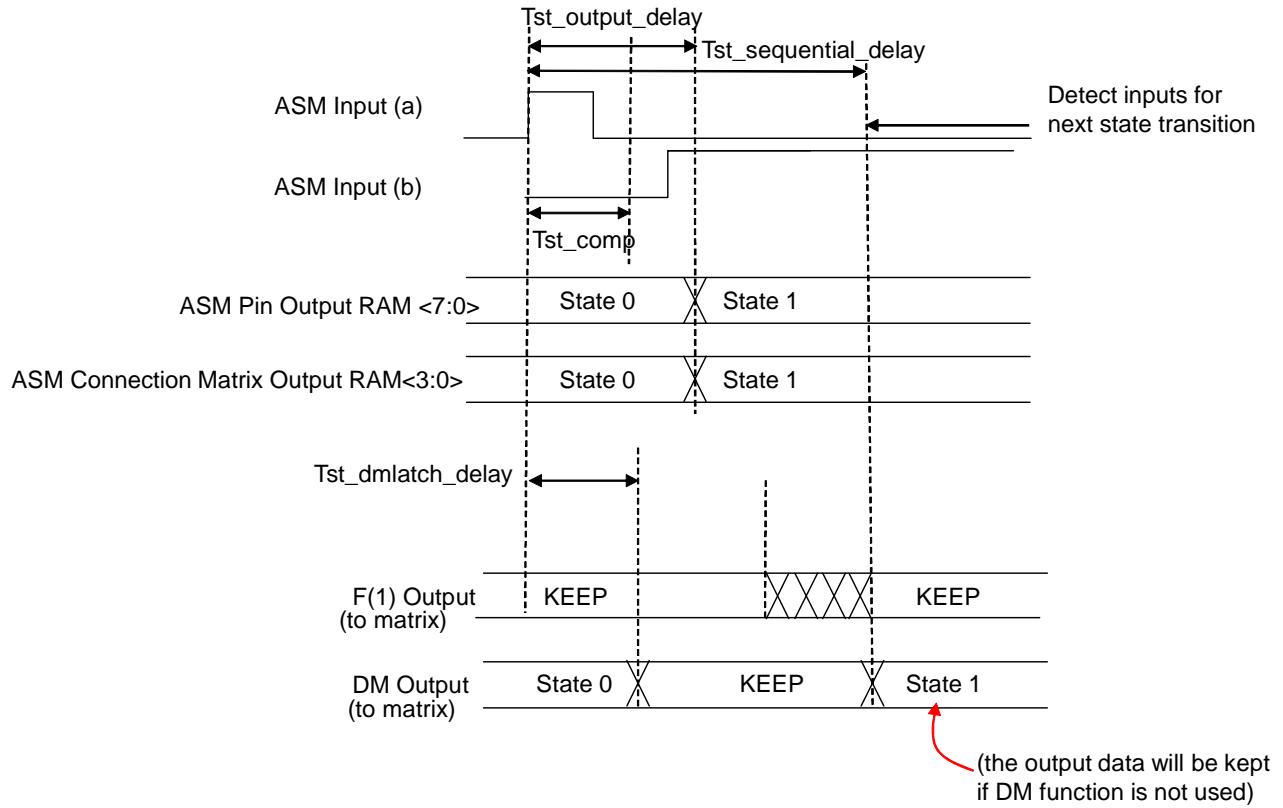

Figure 110: State Transition Timing - Competing Inputs Determinable

14.7.3 ASM State Transition Sequential Timing

It is possible to have a valid input signal for a transition out from a particular state be active before the state is active. If this is the case, the macrocell will only stay in that particular state for $T_{st_sequential_delay}$ time before making the transition to the next state. An example of this sequential behavior is shown in Figure 111 and the associated timing is shown in Figure 112.

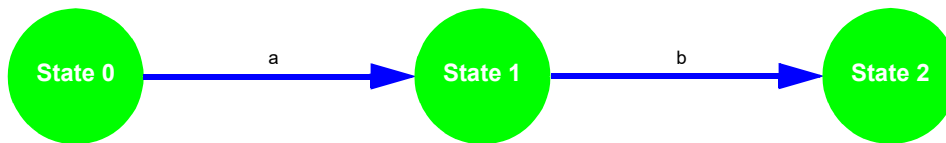

Figure 111: State Transition - Sequential

GreenPAK Programmable Mixed-Signal Matrix with Asynchronous State Machine and Dual Supply

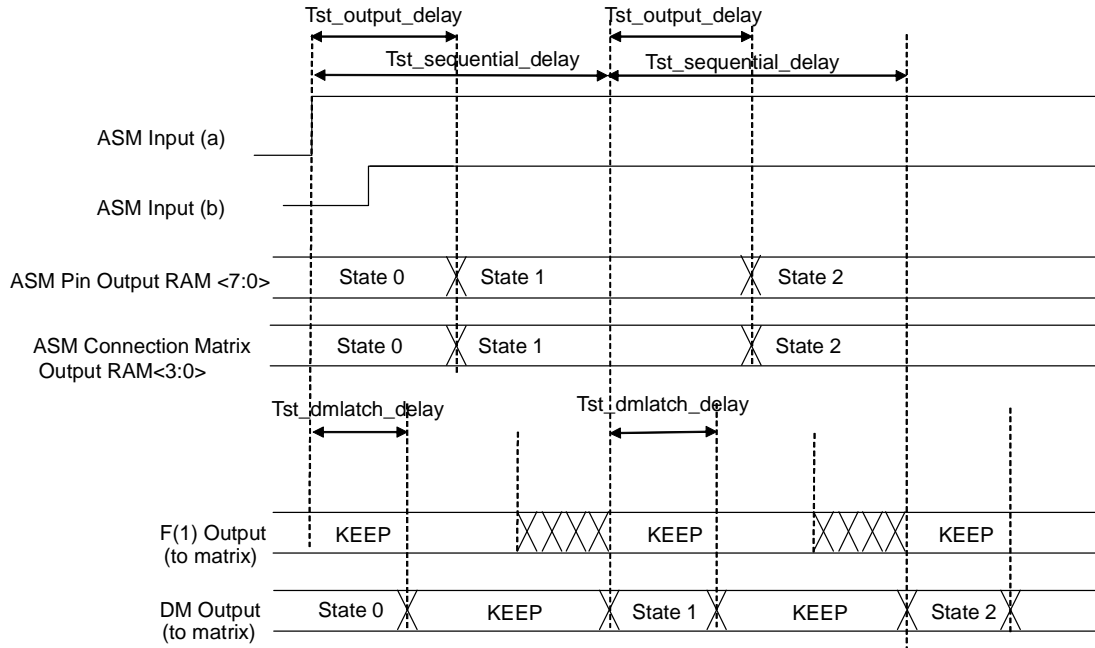

Figure 112: State Transition - Sequential Timing

14.7.4 State Transition Closed Cycling

It is possible to have a closed cycle of state transitions that will run continuously, if there are valid inputs that are active at the same time. The rate at which the state transitions will take place is determined by $T_{st_sequential_delay}$, which determines the timing from one state transition signal that is accepted (and causes a state transition) to the ASM Subsystem being ready for the next input signal. The example shown in Figure 113 involves cycling between two states, but any number of two – twelve states can be included in state transition closed cycling of this nature. Figure 114 shows the associated timing for closed cycling.

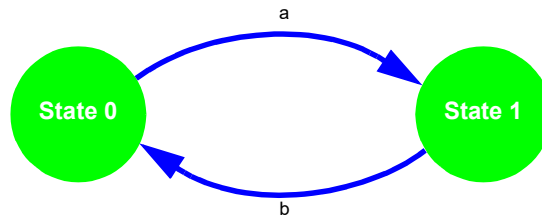

Figure 113: State Transition - Closed Cycling

GreenPAK Programmable Mixed-Signal Matrix with Asynchronous State Machine and Dual Supply

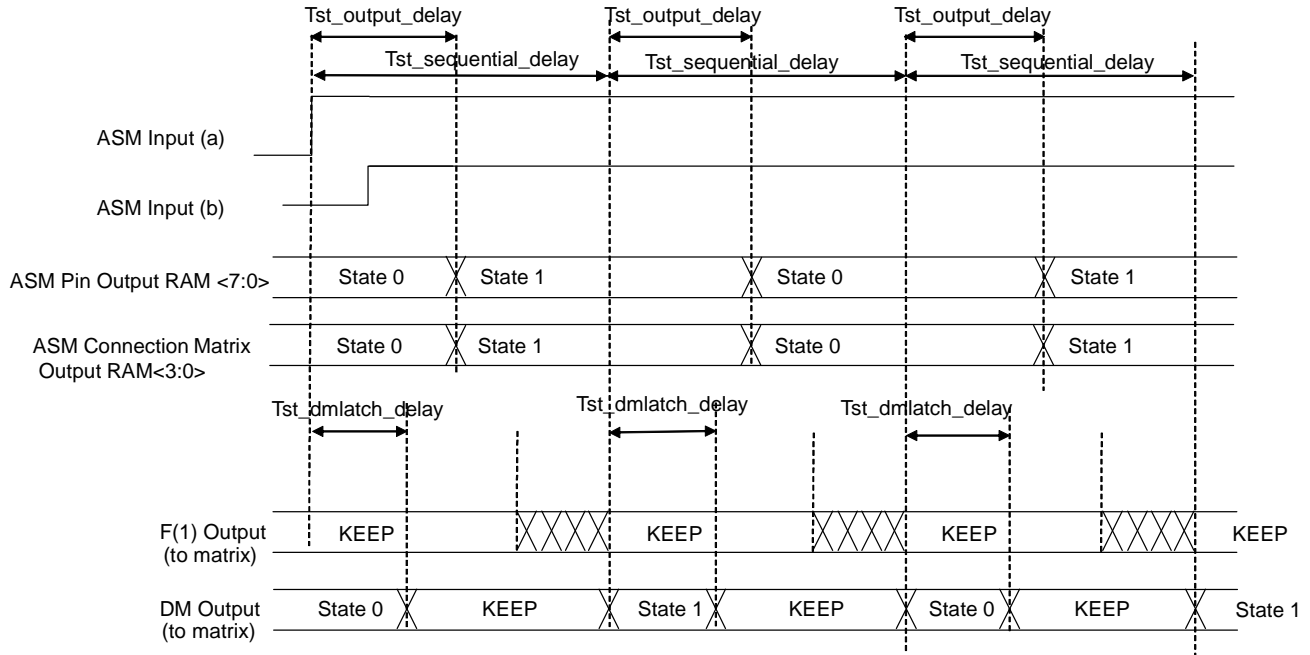

Figure 114: State Transition - Closed Cycling Timing

GreenPAK Programmable Mixed-Signal Matrix with Asynchronous State Machine and Dual Supply

15 Asynchronous State Machine Macrocell

15.1 ASYNCHRONOUS STATE MACHINE OVERVIEW

The Asynchronous State Machine macrocell is one of several macrocells in the Asynchronous State Machine Subsystem, and its specific role is to hold one active state at a time, and to facilitate user defined state transitions in a fast and power efficient manner. This macrocell is designed to allow the user to create state machines with between 2 to 12 states. When combined with the other macrocells in the ASM subsystem [four Dynamic Memory (DMx_x) macrocells, three Matrix Interface (MIx) macrocells, and one f(1) Computation Macrocell], the user has flexibility to define the available states, the available state transitions, and the input signals (a, b, c ...) that will cause transitions from one state to another state, as shown in the example in [Figure 115](#).

The ASM macrocell has a total of 8 input signal lines, as shown in [Figure 116](#), which come from a combination of three Matrix Interface (MI) macrocell outputs and DM macrocell outputs. Of these 8 inputs, 3 are user selectable inputs coming from the three Matrix Interface (MI) macrocells (one per macrocell) to the ASM macrocell. There are also 4 inputs that come from the DMx_x macrocells (one per macrocell). There is 1 ASM_nReset input that is for driving a state transition in the ASM macrocell to a user defined Initial/Reset state.

The ASM macrocell has a total of 12 output signal lines, as shown in [Figure 117](#). There are a total of 4 output signals which go to the Connections Matrix inputs, and from there can be routed to other internal macrocells or pins. The 4 output signals are user defined for each of the possible 12 states. There are a total of 8 output signals which go directly to the 8 GPOs. The 8 outputs are user defined for each of the possible 12 states.

In using this macrocell, the user must take into consideration the critical timing required on all input and output signals. The timing waveforms and timing specifications for this macrocell are all measured relative to the input signals (which come into the macrocell on the Connection Matrix outputs) and on the outputs from the macrocell (which are direct connections to Connection Matrix inputs). The user must consider any delays from other logic and internal chip connections, including IO delays, to insure that signals are properly processed, and state transitions are deterministic.

It is also important to note that the timing for the ASM Subsystem will change based on changes in temperature and system voltage. The user design that implements a state machine function must take into consideration, and be tolerant of this variation

The GPAK Designer development tools support user designs for the ASM macrocell at both the physical level and logic level. [Figure 116](#) is a representation of the user design at the logical level, and [Figure 116](#) shows the physical resources inside the various macrocells in the ASM Subsystem. To best utilize this subsystem, the user must develop a logical representation of their desired state machine, as well as a physical mapping of the input and outputs required for the desired functionality.

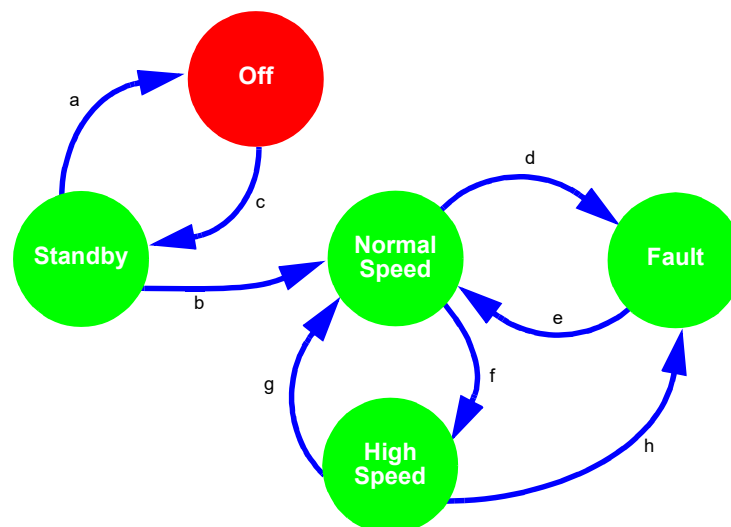

Figure 115: Asynchronous State Machine State Transitions

GreenPAK Programmable Mixed-Signal Matrix with Asynchronous State Machine and Dual Supply

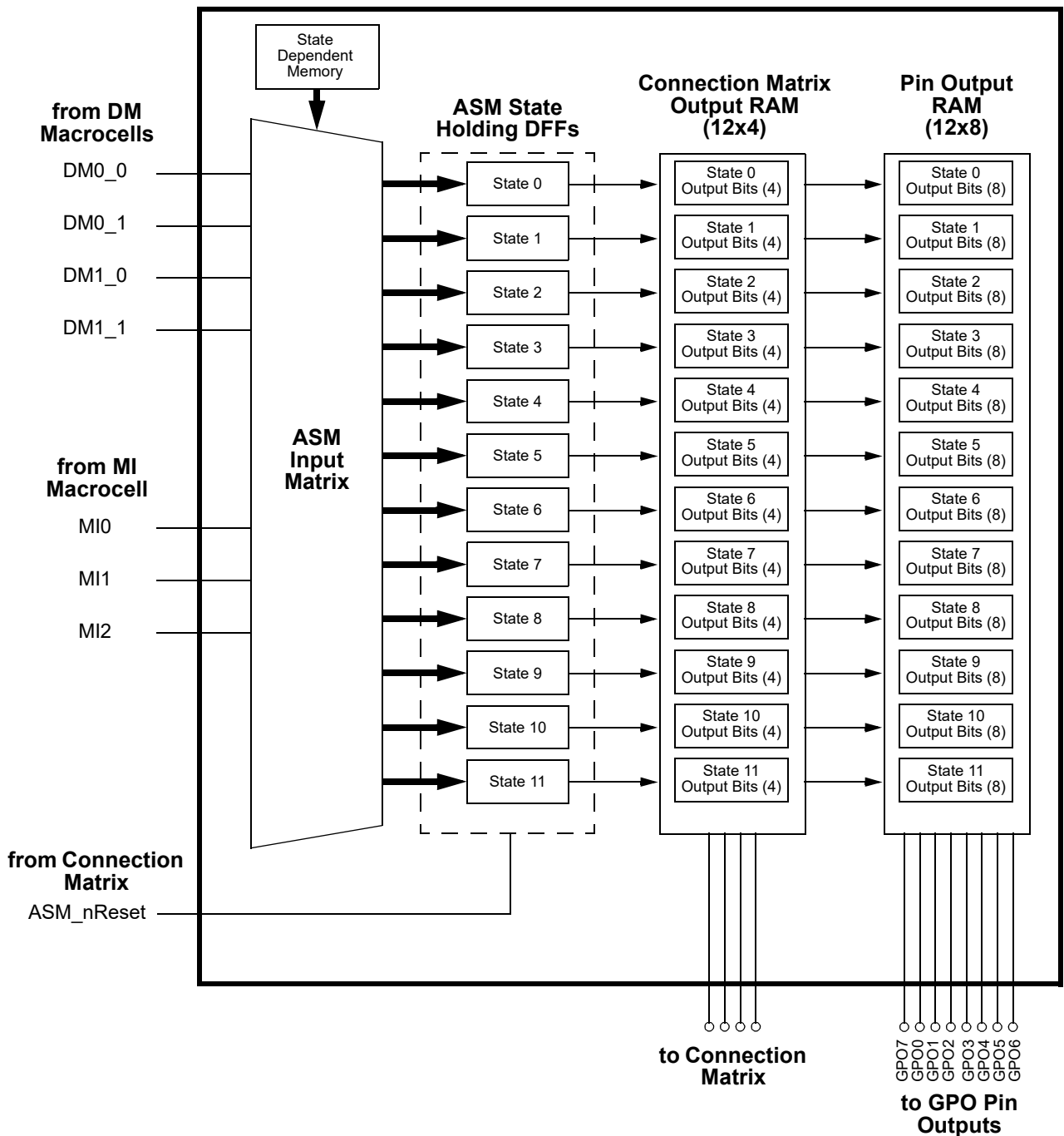

Figure 116: 12 State ASM Macrocell

15.2 ASM MACROCELL INPUT SIGNALS

The ASM macrocell has a total of 8 input signal lines, as shown in Figure 116, which come from a combination of Connection Matrix outputs and DM macrocell outputs.

There are 3 user selectable input signals that come from the MIx macrocells (one per macrocell) to the ASM macrocell. These signals are shown in Figure 118, highlighted in green. Each of these input signals are level sensitive and active high. A high level signal on any of these inputs can be enabled to drive a state transition, depending on the coding in the ASM Input Matrix.

GreenPAK Programmable Mixed-Signal Matrix with Asynchronous State Machine and Dual Supply

There are 4 input signals that come from the DM_{x_x} macrocells (one per macrocell). These signals are shown in Figure 118, highlighted in blue. Each of these input signals are level sensitive and active high. A high level signal on any of these inputs can be enabled to drive a state transition, depending on the coding in the ASM Input Matrix.

There is 1 ASM_nReset input that is for driving a state transition in the ASM macrocell to an user defined Initial/Reset state. This signal is shown in Figure 118, highlighted in yellow. This input signal is level sensitive and active low.

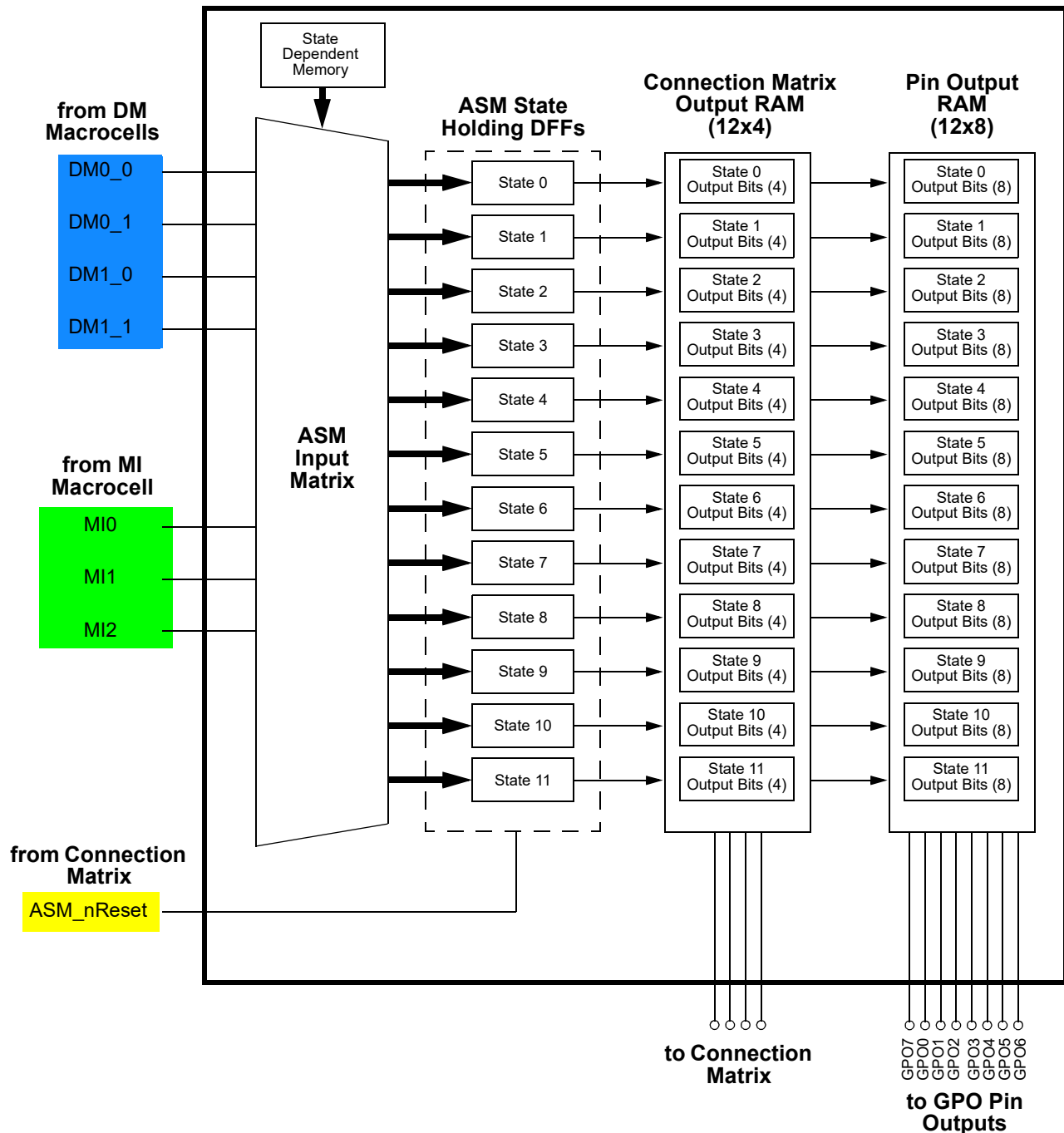

Figure 117: ASM Macrocell Input Signals

GreenPAK Programmable Mixed-Signal Matrix with Asynchronous State Machine and Dual Supply

15.2.1 ASM Macrocell Output Signals

The ASM macrocell has a total of 12 output signal lines, as shown in [Figure 118](#).

There are a total of 4 output signals which go to the Connections Matrix inputs, and from there can be routed to other internal macrocells or pins. These signals are shown in [Figure 118](#), highlighted in green. The 4 outputs are user defined for each of the possible 12 states. The user defined values for these outputs is stored in the Connection Matrix Output RAM which is 12 x 4 in size (12 states x 4 outputs), for a total of 48 bits.

There are a total of 8 output signals which go directly to the 8 GPOs. These signals are shown in [Figure 118](#), highlighted in blue. The 8 outputs are user defined for each of the possible 12 states. The user defined values for these outputs is stored in the Connection Matrix Output RAM which is 12 x 8 in size (12 states x 8 outputs), for a total of 96 bits. Each of the 8 GPOs has an internal mux that will either accept a signal from the outputs defined here, or directly from a Connection Matrix output. This mux in each GPO is under control of a register bit.

GreenPAK Programmable Mixed-Signal Matrix with Asynchronous State Machine and Dual Supply

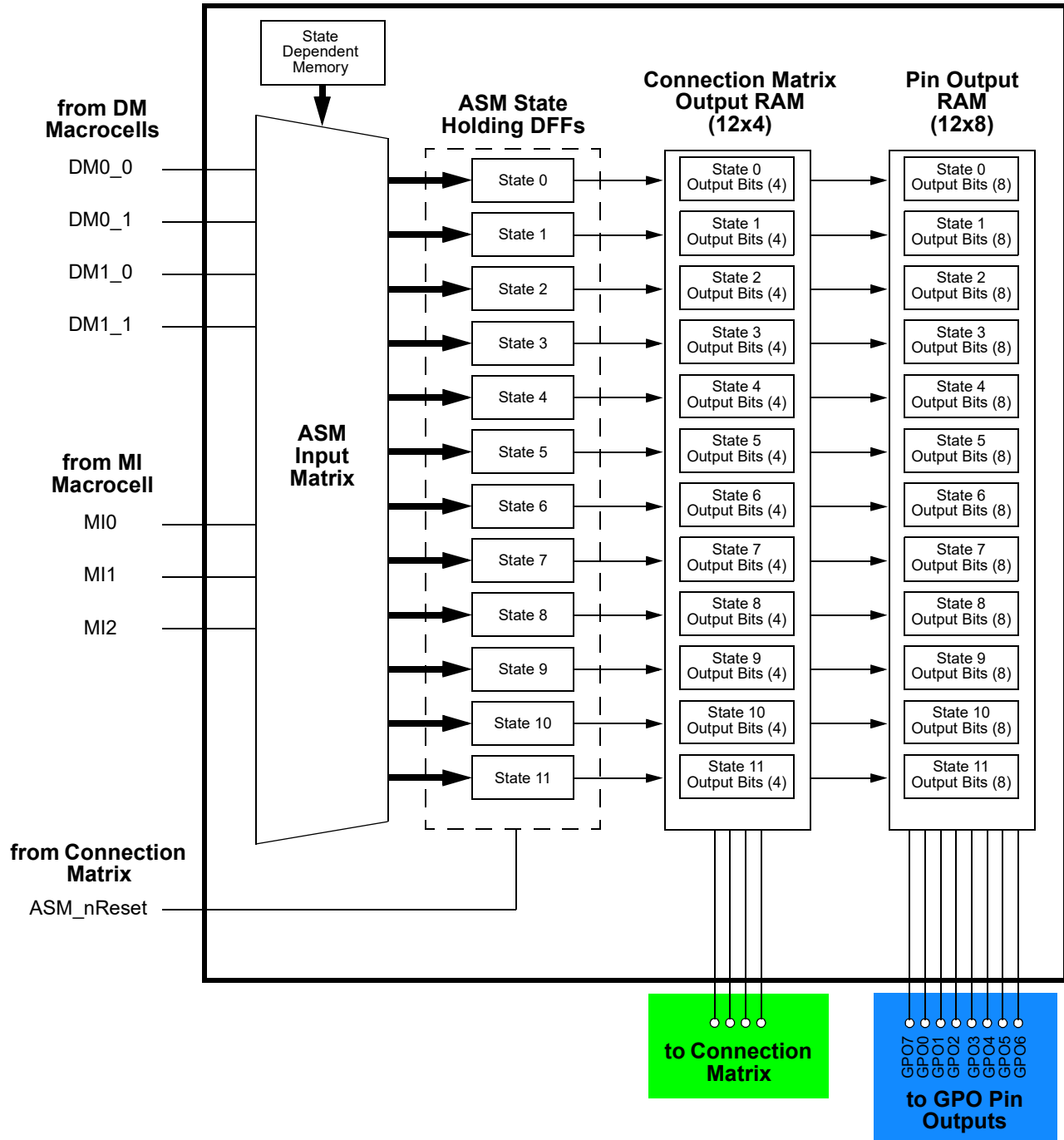

Figure 118: ASM Macrocell Output Signals

15.3 ASM LOGICAL VS. PHYSICAL DESIGN

A successful design with the ASM macrocell must include both the logic level design, as well as the physical level design. The GPAK Designer development software support user designs for the ASM macrocell at both the logic level and physical level. The logic level design of the user defined state machine takes place inside the ASM Editor. In the ASM Editor, the user can select and name states, define and name allowed state transitions, define the Initial/Reset state, and define the output values for

GreenPAK Programmable Mixed-Signal Matrix with Asynchronous State Machine and Dual Supply

the 8 outputs in the Pin Output RAM and 4 outputs in the Connection Matrix Output RAM. The physical level design takes place in the general GPAK Designer window, and here the user makes connections for the sources for ASM input signals, as well as making connections for destinations for ASM output signals.

GreenPAK Programmable Mixed-Signal Matrix with Asynchronous State Machine and Dual Supply

16 Dynamic Memory Macrocell

16.1 DYNAMIC MEMORY MACROCELL OVERVIEW

The ASM Sub-System includes several discrete macrocells, including the ASM macrocell, four Dynamic Memory (DM_x) macrocells, and one f(1) Computation Macrocell. These macrocells are designed to work as a system for building user defined state machines.

The Dynamic Memory (DM) macrocells have the characteristic that they can change internal configuration characteristics and their connections to the Connection Matrix based on the current state of the State Machine (SM) macrocell. This is accomplished by making different memory register bit settings contained within the macrocell active, based on the current active state of the SM. This allows the user to “repurpose” the resources inside these macrocells to match the circuit needs in various states.

There are two different types of DM macrocells, which vary slightly in the resources available inside the DM macrocell, as well as the connectivity to the Connection Matrix. The SLG46880/81 has a total of four DM macrocells. DM0_0 and DM0_1 have the same structure and resources as each other, and DM1_0 and DM1_1 also have the same structure and resources as each other. The DM0_x macrocells include all the functionality of the DM1_x macrocells, but they also have an output control capability, which is optimized for using the output of this macrocell to drive IO pin output states through the Connection Matrix. The DM CNT included in the DM0_x macrocells has more operating modes than the equivalent structure in the DM1_x macrocells.

Each DM macrocell has a DM_x_x Configuration Register Table, which is a bank of 6 DM_x_x Configuration Registers. The bits in these registers hold user selections which define all functional aspects of the behavior for the DM macrocell, including input connections from the Connection Matrix, DM LUT settings, DM CNT settings, and settings of muxing internal to the DM macrocell. The fact that there are 6 Configuration Registers means that there can only be a total of six unique configurations for each DM_x_x macrocell. There are a total of twelve states, which means that the user can either re-use the configuration coded in a particular DM_x_x Operating Mode Register in more than one state, or not use some DM_x_x macrocells in some states.

Each DM macrocell has a DM_x_x Configuration Selection Table, which is a bank of 12 Configuration Selection Registers, one for each state of the State Machine macrocell. The bits in these registers hold the user's selection of DM functional behavior, by mapping to a particular selection in the Configuration Register Table, based on the current state of the State Machine macrocell.

GreenPAK Programmable Mixed-Signal Matrix with Asynchronous State Machine and Dual Supply

16.2 DM0_0 AND DM0_1 MACROCELL ARCHITECTURE

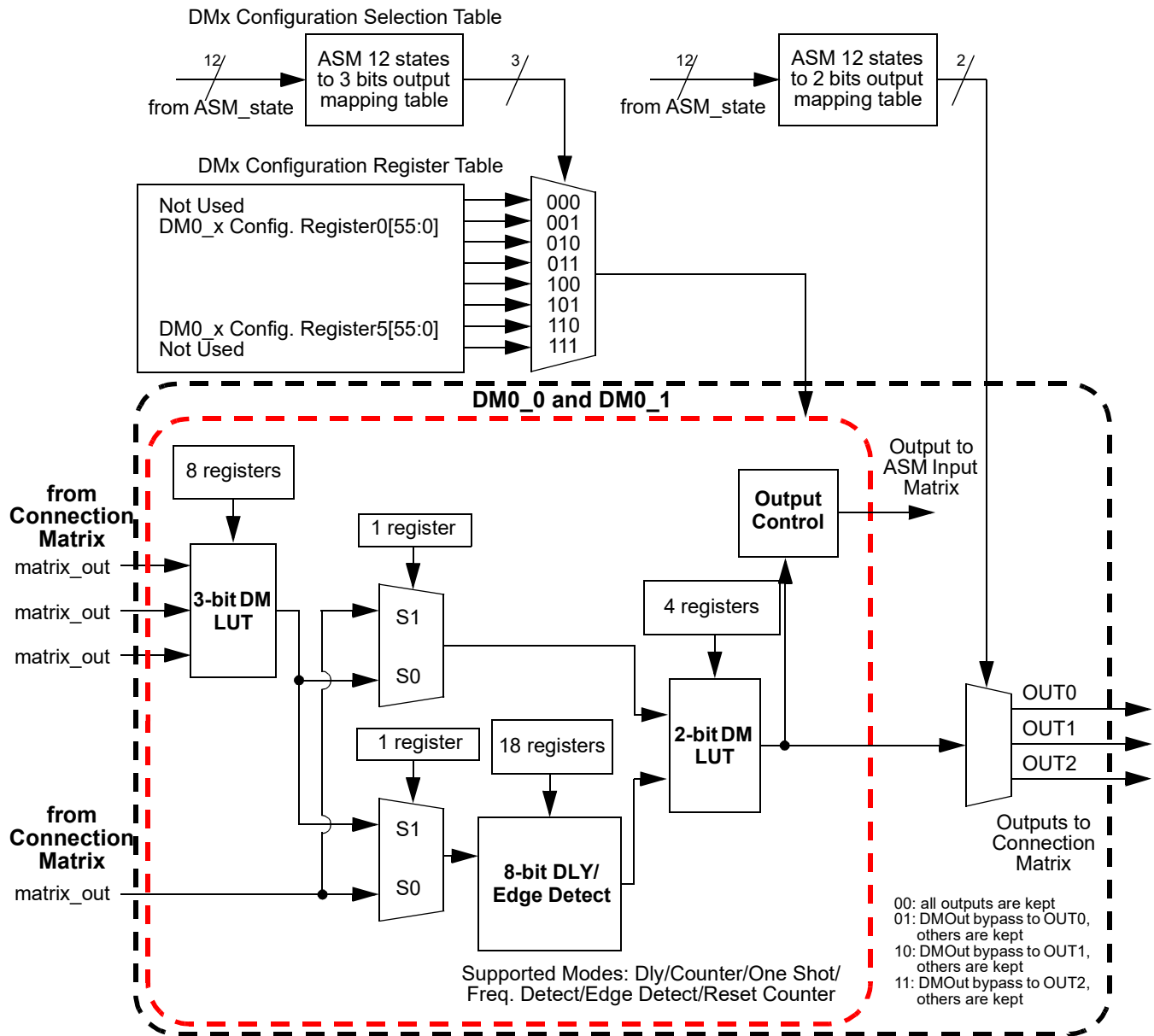

Figure 119: DM0_0/DM0_1

16.3 DM1_0 AND DM1_1 MACROCELL ARCHITECTURE

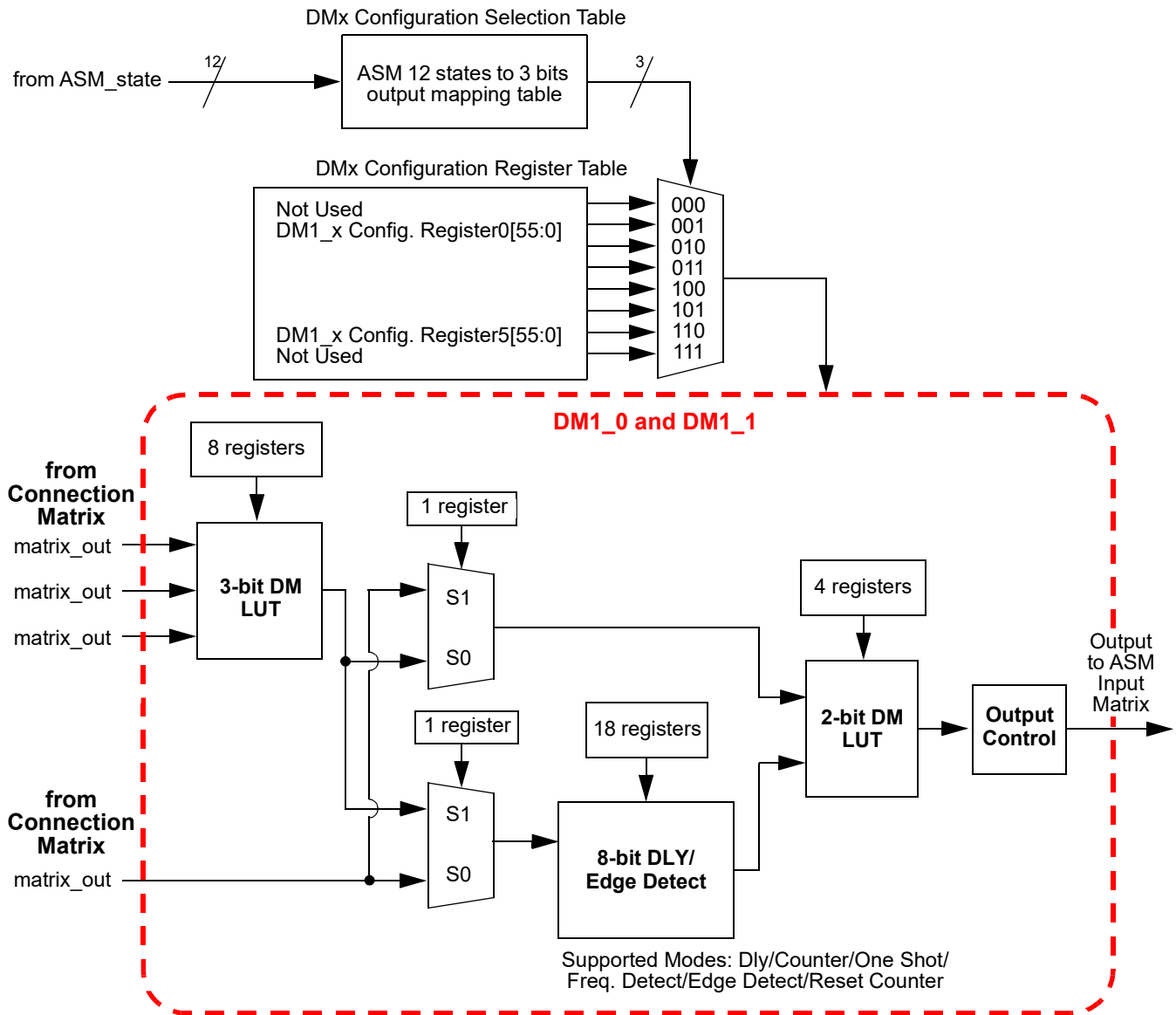

Figure 120: DM1_0/DM1_1

GreenPAK Programmable Mixed-Signal Matrix with Asynchronous State Machine and Dual Supply

16.4 DMX_X MACROCELL INPUT SIGNALS

Each DMx_x macrocell has 4 digital input signals coming from the Connection Matrix and from there can be routed to other internal macrocells or pins. These 4 signals are shown in Figure 121 and Figure 122, highlighted in blue.

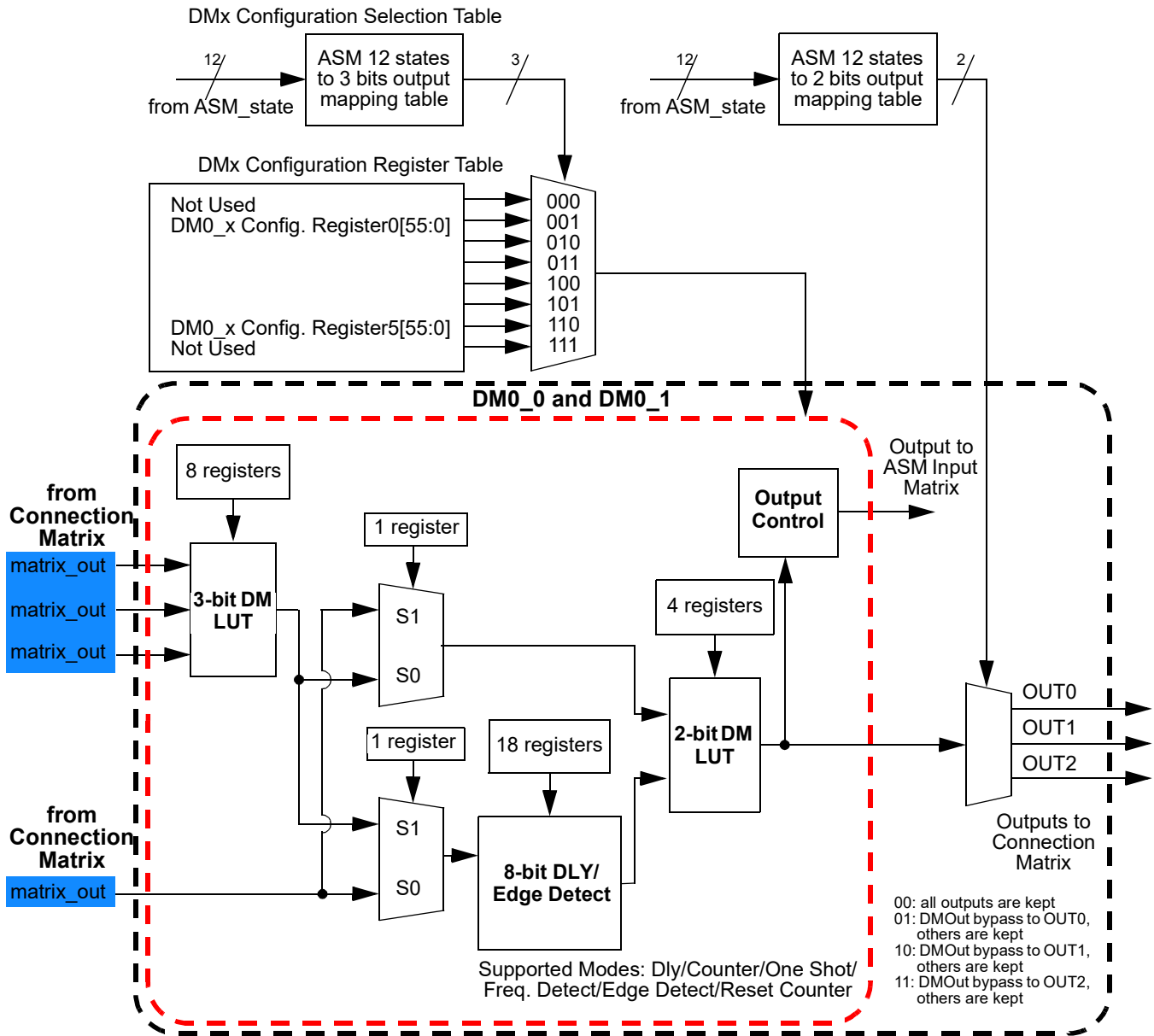

Figure 121: DM0_0/DM0_1 Inputs

GreenPAK Programmable Mixed-Signal Matrix with Asynchronous State Machine and Dual Supply

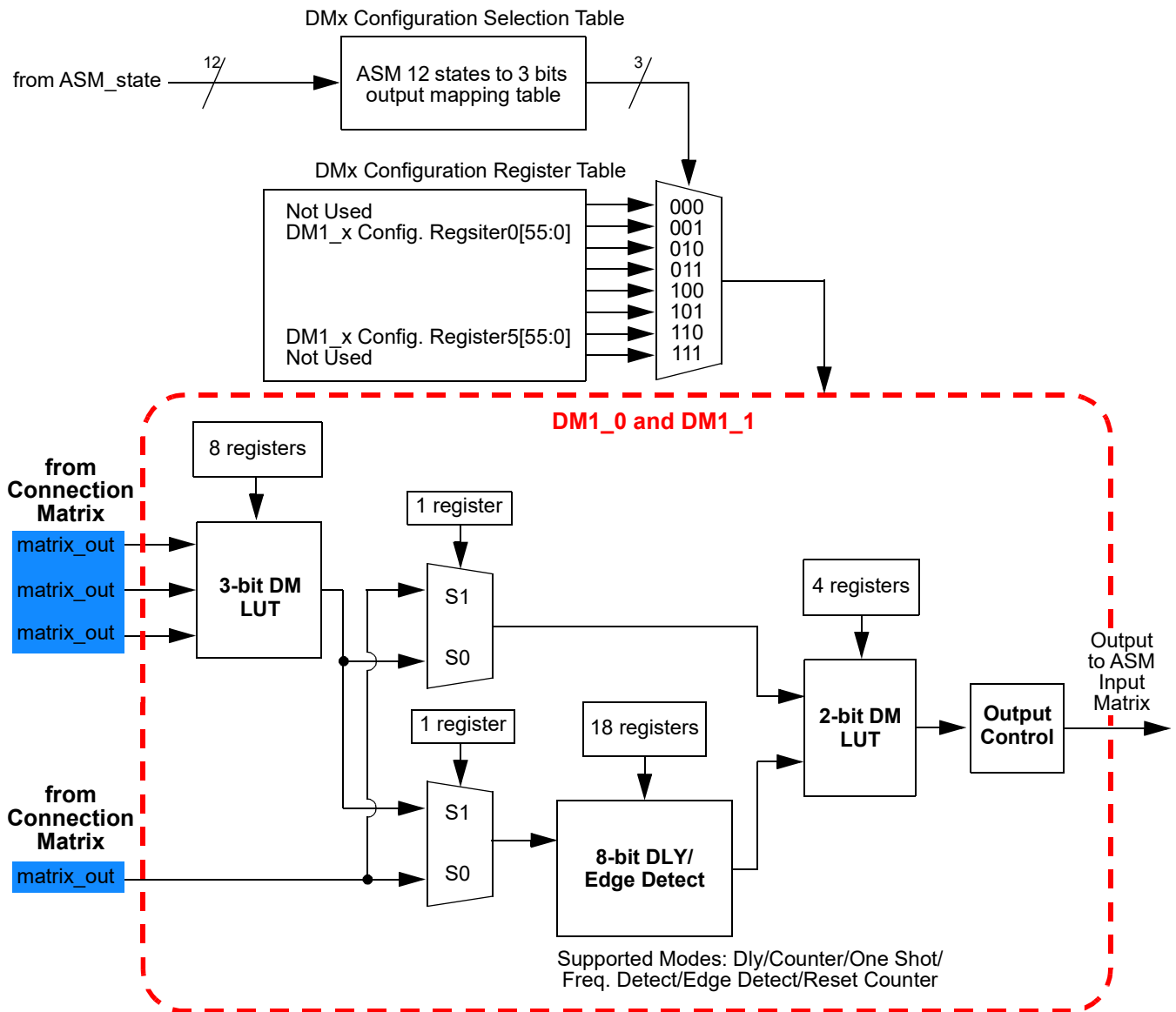

Figure 122: DM1_0/DM1_1 Inputs

GreenPAK Programmable Mixed-Signal Matrix with Asynchronous State Machine and Dual Supply

16.5 DMX_X MACROCELL OUTPUT SIGNALS

Each DMx_x macrocell has 1 digital output signal, which goes directly to the ASM Input Matrix inside the ASM Macrocell. This signal is shown in Figure 123 and Figure 124, highlighted in blue.

Additionally, the DM0_0 and DM0_1 Macrocells each have 3 digital output signals which go to the Connection Matrix and from there can be routed to other internal macrocells or pins. These 3 signals are shown in Figure 123, highlighted in green.

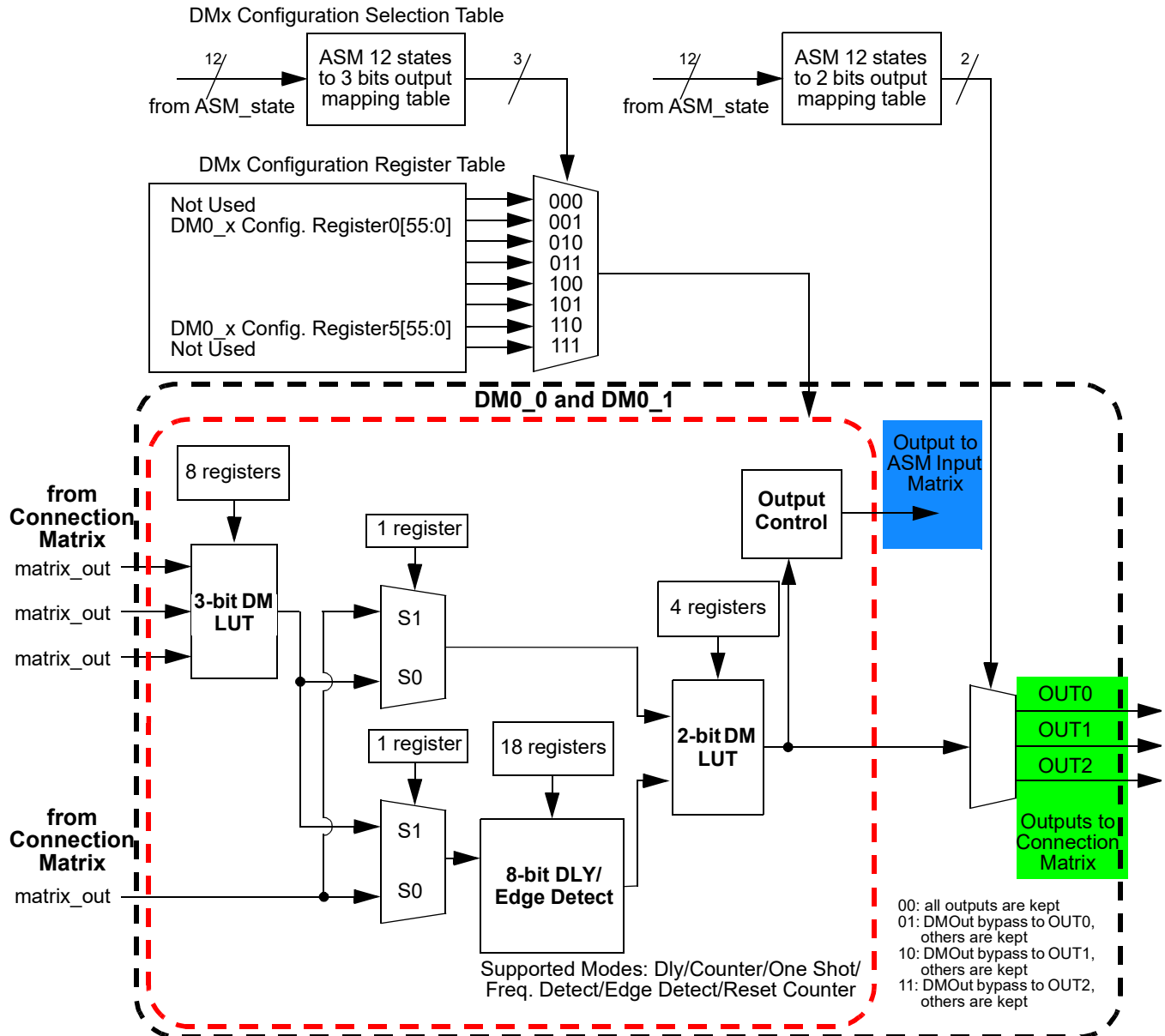

Figure 123: DM0_0/DM0_1 Outputs

GreenPAK Programmable Mixed-Signal Matrix with Asynchronous State Machine and Dual Supply

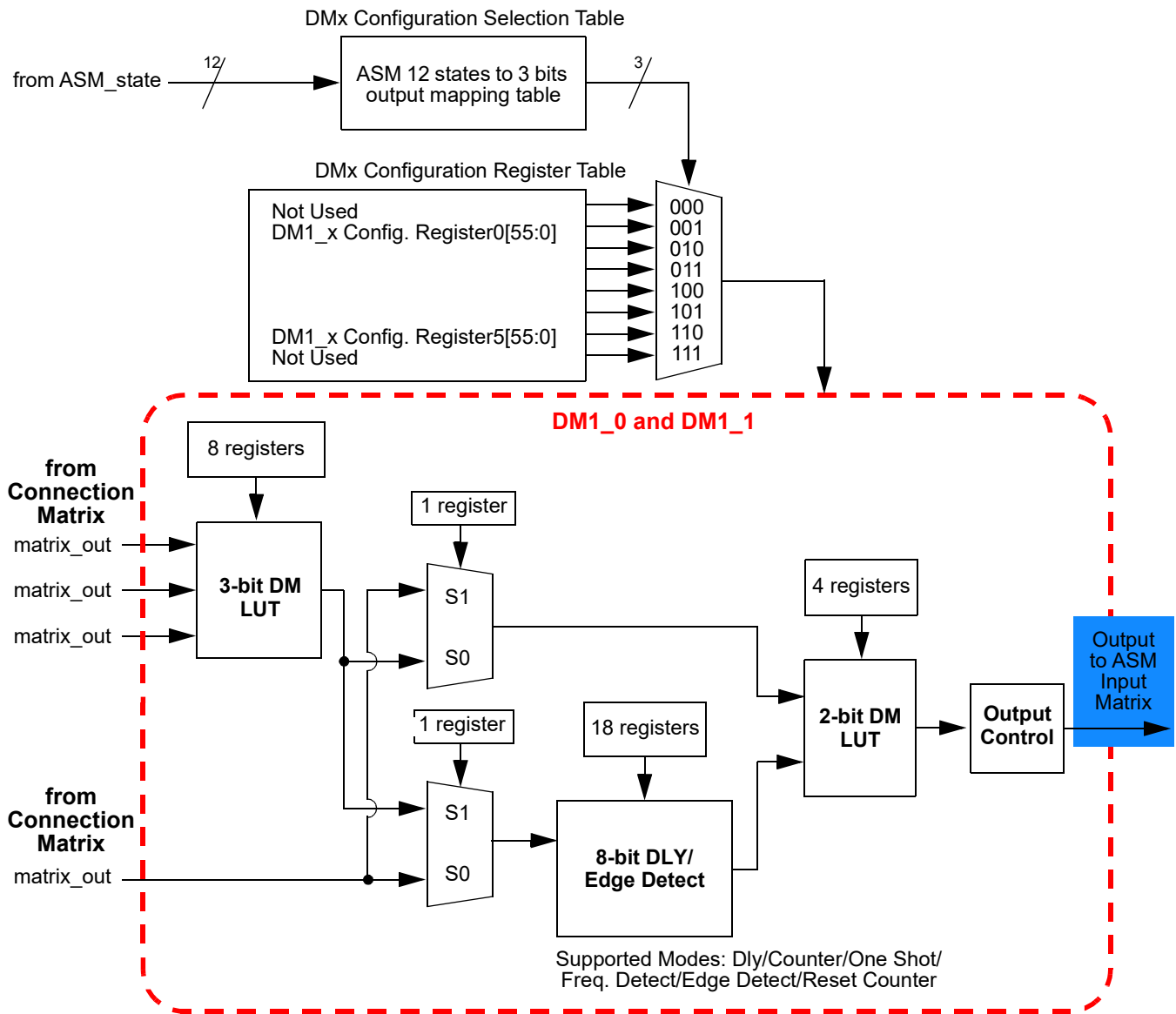

Figure 124: DM1_0/DM1_1 Outputs

GreenPAK Programmable Mixed-Signal Matrix with Asynchronous State Machine and Dual Supply

17 f(1) Computation Macrocell

17.1 F(1) COMPUTATION MACROCELL OVERVIEW

The f(1) Computation Macrocell consists of a specialized state machine which is optimized for simple data manipulation activities on single data bit values. The operation of this macrocell can be initiated whenever the ASM Macrocell enters a new state, and can execute a string of up to 12 commands for loading and storing 1 bit data, as well as doing simple logical functions such as ANDs, ORs, and XORs.

The only time the f(1) Computation Macrocell will begin to execute instructions is when the ASM Macrocell first enters a new state. At that point in time, the f(1) Computation Macrocell will execute the user selected commands, if any, that are associated with that particular ASM state. When the f(1) Computation Macrocell completes the commands, it will then relinquish control back to the ASM Macrocell. During the time that the f(1) Computation Macrocell is active, there can be no activity in the ASM macrocell (i.e., the ASM Macrocell is prevented from any state transition during the time when the f(1) Macrocell is active).

The f(1) Computation Macrocell has two digital inputs, ASM_nReset and f1_Interrupt. An active signal on either of these inputs will immediately halt any command execution for the f(1) Computation Macrocell, and will immediately relinquish control back to the ASM macrocell.

The f(1) Command Register Table has 4 registers, each of which holds a string of up to 12 commands to run when the f(1) Computation Macrocell is initiated. These 4 registers allow for 4 different command strings that the user can choose from. The f(1) Command Selection Table has 12 entries (one per ASM state), which allow the user to select which of the f(1) Command Registers will be used upon entry into each state. The user can also select that no commands are used in a particular state (one of the selection options for each entry in the f(1) Command Selection Table), in which case the f(1) Computation Macrocell is completely bypassed upon entry to that particular state.

There are a total of 8 analog inputs coming from various pins which can be muxed into the positive input for the f(1) Analog Comparator inside the f(1) Computation Macrocell. The f(1) Analog Comparator can be re-programmed for analog input source and negative input reference settings. The user selections for both positive input signal and negative reference are included as part of the information stored in the f(1) Command Register Table. This allows the user to make different analog measurements that are state dependent in their analog sources and reference settings.

This macrocell also includes a f(1) Memory Stack, which is 1 bit wide by 16 deep memory which is organized as a stack, and can serve as a data source or data destination for the commands running on the macrocell. LOADx commands will push data down into the stack. OUTx commands will pop data off the stack, and send to the contents of the Top-Of-Stack to one of three outputs of the f(1) macrocell to the Connection Matrix. The contents of this memory are not changed during ASM state transitions, and are only changed by the commands running inside the f(1) Computation Macrocell itself. The initial memory stack values are loaded from registers [3279:3264].

GreenPAK Programmable Mixed-Signal Matrix with Asynchronous State Machine and Dual Supply

17.2 F(1) COMPUTATION MACROCELL ARCHITECTURE

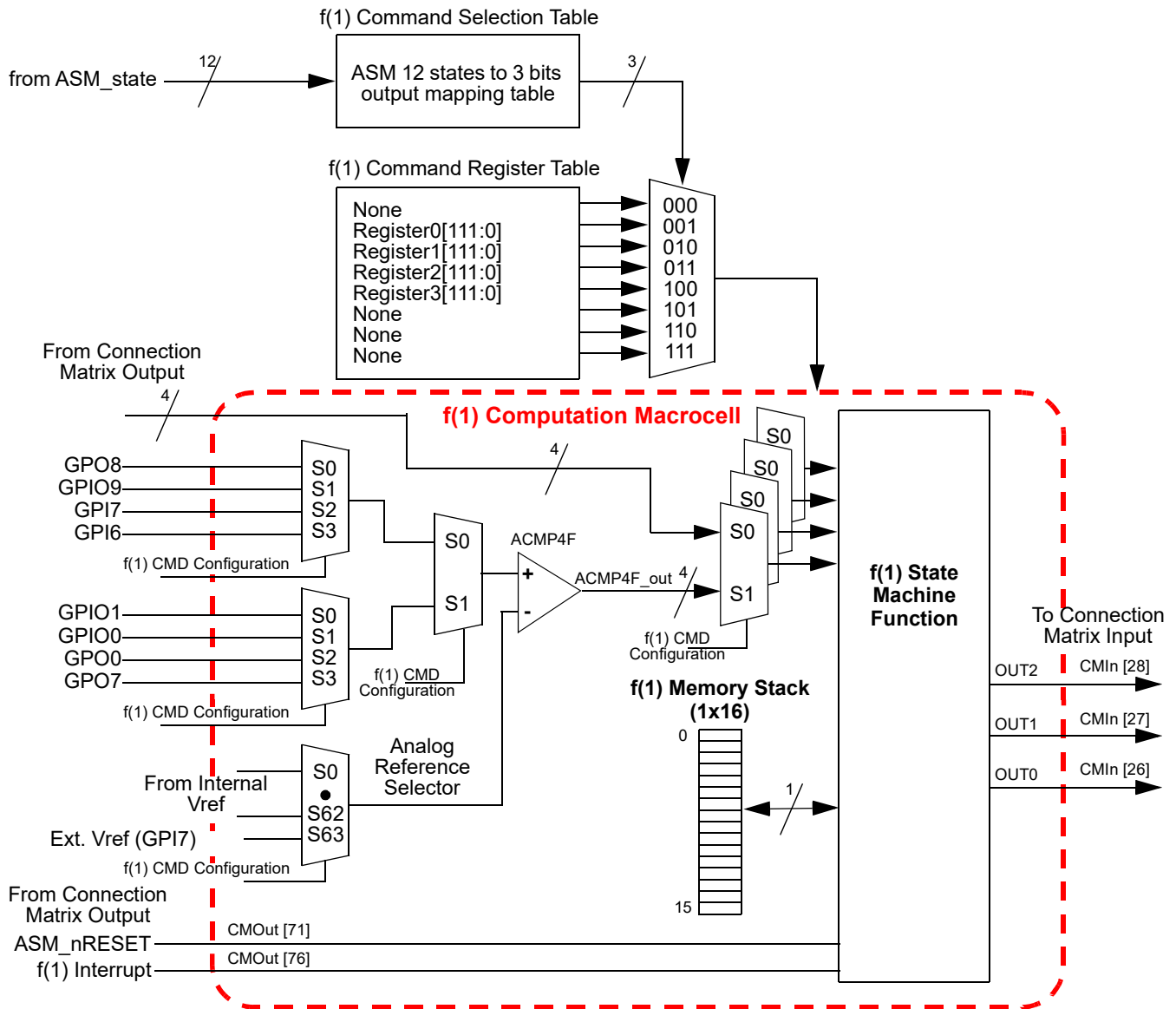

Figure 125: f(1) Computation Macrocell Architecture

17.3 F(1) COMPUTATION MACROCELL INPUT SIGNALS

The f(1) Computation Macrocell has 6 digital input signals, ASM_nReset, f1_Interrupt, and four inputs from Connection Matrix outputs. An active signal on either of the first 2 inputs will immediately halt any command execution for the f(1) Computation Macrocell, and will immediately relinquish control back to the ASM macrocell. The ASM_nReset is a level sensitive signal, and active low. The f1_Interrupt is a level sensitive signal, and active high. These signals are shown in Figure 126, highlighted in blue. Also there are 4 digital inputs from the Connection Matrix, which can be routed to any Connection Matrix outputs from the f(1) Commands. These signals are shown on Figure 126, highlighted in yellow.

GreenPAK Programmable Mixed-Signal Matrix with Asynchronous State Machine and Dual Supply

There are a total of 8 analog inputs coming from various pins which can be muxed into the positive input for the f(1) Analog Comparator inside the f(1) Computation Macrocell. These signals are shown in Figure 102, highlighted in green. The f(1) Analog Comparator can be re-programmed for analog input source and negative input reference settings with settings inside the LOADx command. The user selections for both positive input signal and negative reference are included as part of the information stored in the f(1) Command Register Table. This allows the user to make different analog measurements that are state dependent in their analog sources and reference settings.

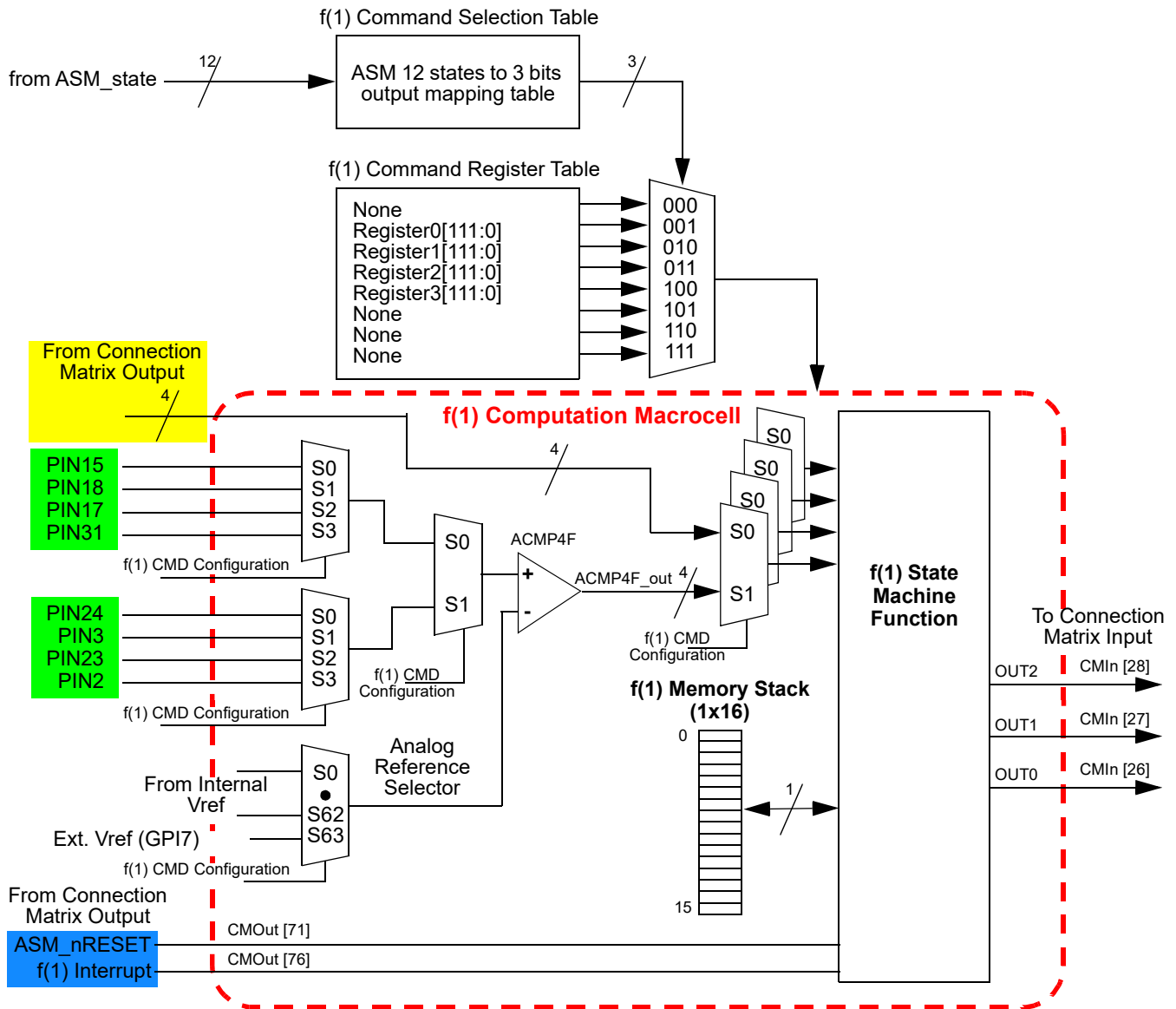

Figure 126: f(1) Computation Macrocell Input Signals

The f(1) interrupt signal comes from Connection Matrix Output. The high level f(1) interrupt signal forces the f(1) computation macrocell to immediately finish command execution and return control to the ASM similar to the END command. It is possible to load initial memory stack with the f(1) interrupt signal when register [3766] is high.

The ASM_nRESET low level signal forces the ASM macrocell and the f(1) computation macrocell to an initial state and an initial memory stack value.

GreenPAK Programmable Mixed-Signal Matrix with Asynchronous State Machine and Dual Supply

17.4 F(1) COMPUTATION MACROCELL OUTPUT SIGNALS

The f(1) Computation Macrocell has 3 digital output signals that go to the Connection Matrix, and from there can be routed to other internal macrocells or pins. These signals are shown in Figure 127, highlighted in blue. The state of these output signals are under user control, and are changed based on the Output commands.

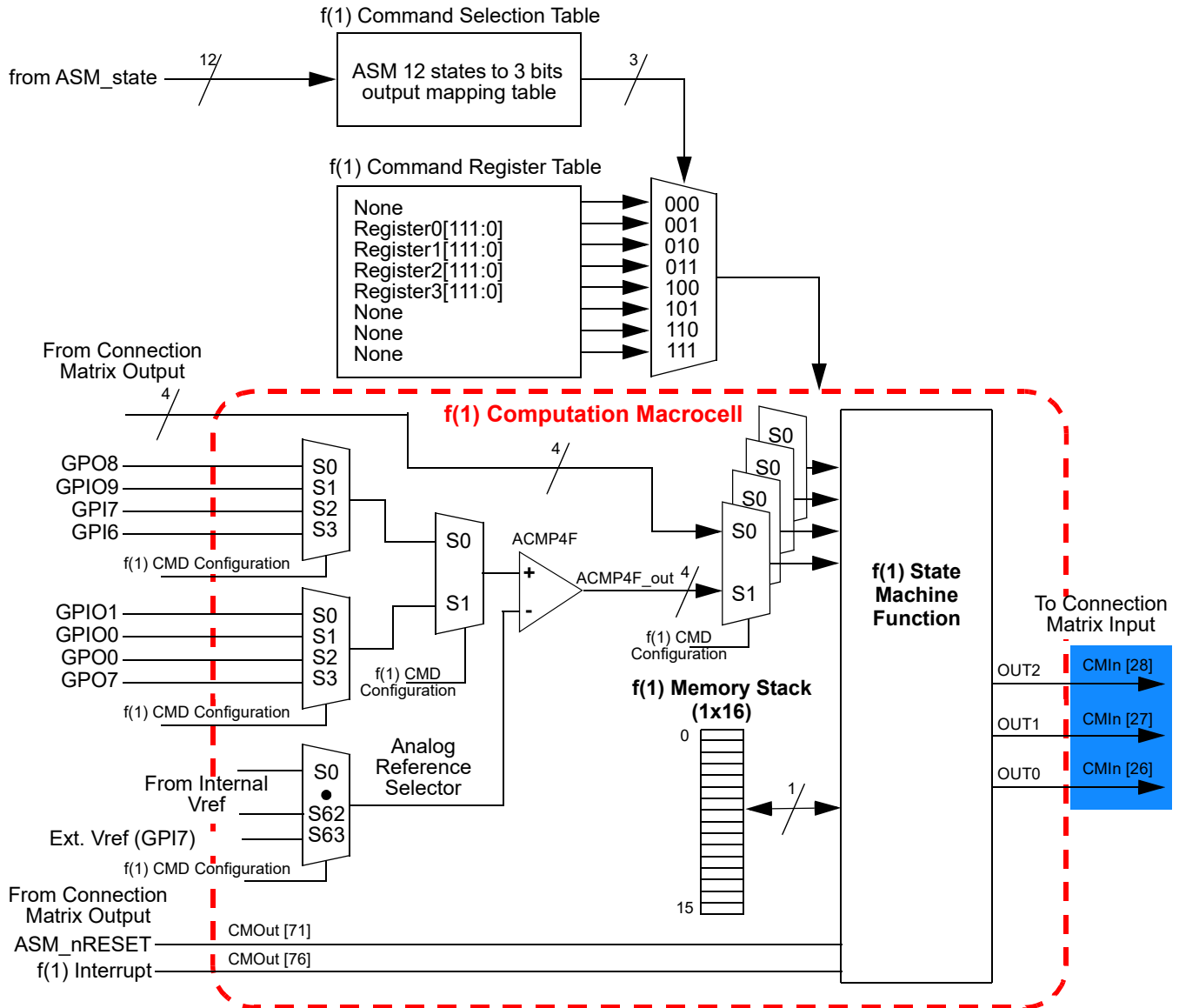

Figure 127: f(1) Computation Macrocell Output Signals

17.5 F(1) COMMAND REGISTERS

The f(1) Computation Macrocell consists of a specialized state machine which is optimized for simple data manipulation activities on single data bit values. The f(1) Computation Macrocell must be used for accessing the 8:1 analog multiplexer and associated analog comparator. The f(1) is also useful for storing state independent values, looping operations such as periodic signal checks, and for performing simple repetitive logic functions.

The operation of this macrocell can be initiated whenever the ASM Macrocell enters a new state, and can execute a string of up to 12 commands for loading and storing 1 bit data, as well as doing simple logical functions such as ANDs, ORs, and XORs.

GreenPAK Programmable Mixed-Signal Matrix with Asynchronous State Machine and Dual Supply

The f(1) Command Register Table has 4 registers, therefore 4 independent f(1) functions can be defined. Each state of the ASM can access one of the four f(1) configurable instances of the f(1).

Each of the four f(1) configurations may contain up to 12 commands which run when the f(1) Computation Macrocell is initiated. The list of available commands is as follows:

Command	Command Name	Command Description
0000	LOAD1	Loads a one bit value to the top of the memory stack (location 0). During the execution of this command, all other values are shifted down 1 location, and the value in location 15 is lost. The data loaded by Load 1 command is defined in the Load 1 register, which defines where the value is to be loaded from such as a pin, the f(1) comparator, and others.
0001	LOAD2	Loads a one bit value to the top of the memory stack (location 0). During the execution of this command, all other values are shifted down 1 location, and the value in location 15 is lost. The data loaded by Load 2 command is defined in the Load 2 register, which defines where the value is to be loaded from such as a pin, the f(1) comparator, and others.
0010	LOAD3	Loads a one bit value to the top of the memory stack (location 0). During the execution of this command, all other values are shifted down 1 location, and the value in location 15 is lost. The data loaded by Load 3 command is defined in the Load 3 register, which defines where the value is to be loaded from such as a pin, the f(1) comparator, and others.
0011	LOAD4	Loads a one bit value to the top of the memory stack (location 0). During the execution of this command, all other values are shifted down 1 location, and the value in location 15 is lost. The data loaded by Load 4 command is defined in the Load 4 register, which defines where the value is to be loaded from such as a pin, the f(1) comparator, and others.
0100	AND	Performs a logical AND to the top two locations in the memory stack (location 0 and location 1). During execution of this command, the two values in the top two stack locations are deleted, and the logical AND result is pushed on the top of stack (location 0). In the process, all other values in the stack are shifted up 1 location, and a 0 is loaded in location 15.
0101	OR	Performs a logical OR to the top two locations in the memory stack (location 0 and location 1). During execution of this command, the two values in the top two stack locations are deleted, and the logical OR result is pushed on the top of stack (location 0). In the process, all other values in the stack are shifted up 1 location, and a 0 is loaded in location 15.
0110	XOR	Performs a logical XOR to the top two locations in the memory stack (location 0 and location 1). During execution of this command, the two values in the top two stack locations are deleted, and the logical XOR result is pushed on the top of stack (location 0). In the process, all other values in the stack are shifted up 1 location, and a 0 is loaded in location 15.
0111	INV	Performs a logical Invert (INV) to the top location in the memory stack (location 0). During execution of this command, the value in the top stack location is deleted, and the logical INV result is pushed on the top of stack. There is no effect on all other values in the stack.
1000	PUSH0	Pushes a 0 into the top location in the memory stack (location 0). During the execution of this command, all other values are shifted down 1 location, and the value in the location 15 is lost.
1001	POP	During execution of this command, values in the stack are shifted up 1 location, and a 0 is loaded in location 15.
1010	DELAY	The execution of commands by the f(1) Computation microcell is delayed by a period of time defined in the configuration of the delay function. Once this time period is completed, the next f(1) instruction will execute.
1011	LOOP with DELAY	If the top location in the memory stack (location 0) is equal to 0, the command execution in the f(1) Macrocell is delayed by a period of time defined in the configuration of the delay function and then executes the f(1) sequence at the specified jump location. If the top location in the memory stack (location 0) is equal to 1, the f(1) Macrocell proceeds with execution of the next command in sequence.
1100	OUT1	Outputs the top location in the memory stack (location 0) on matrix input OUT1.
1101	OUT2	Outputs the top location in the memory stack (location 0) on matrix input OUT2.
1110	OUT3	Outputs the top location in the memory stack (location 0) on matrix input OUT3.
1111	END	Immediately ends execution of commands by f(1) Macrocell, and control is returned to ASM Macrocell.

GreenPAK Programmable Mixed-Signal Matrix with Asynchronous State Machine and Dual Supply

These commands form a machine level language that may be configured within GPAK Designer software using a simple GUI, as opposed to using a typical text editor. See application examples below:

Example #1: Sensor Application showing the command sequence for a potential use case of the f(1) Macrocell.

f(1) Command Sequence	Command	Description
1	INV	Change Top Memory location from 0 → 1.
2	OUT1	Output a 1 to a pin defined by OUT1 register. This can be used to turn on or bias an external sensor.
3	DELAY	Wait for a time defined by DELAY register. This can be used to allow sensor to settle.
4	LOAD1	Capture the output of f(1) ACMP from an analog pin connected to the sensor as defined by the LOAD1 register.
5	LOAD2	Capture the output of a pin as defined by the LOAD2 register. This can be used to check a power good signal.
6	AND	Logically AND the top two values of the 1x16 memory that were just loaded with LOAD1 and LOAD2.
7	OUT2	Output the result of sensor output AND power good signal for a control decision for the ASM.
8	END	ASM can now act on OUT2 signal.

Example #2: Power Good Application showing the command sequence for a potential use case of the f(1) Macrocell.

f(1) Command Sequence	Command	Description
1	LOAD1	Capture the output of f(1) ACMP from an analog pin connected to power rail 1 as defined by the LOAD1 register. A "1" means that power is good on power rail 1.
2	LOAD2	Capture the output of f(1) ACMP from an analog pin connected to power rail 2 as defined by the LOAD2 register. A "1" means that power is good on power rail 2.
3	LOAD3	Capture the output of f(1) ACMP from an analog pin connected to power rail 3 as defined by the LOAD3 register. A "1" means that power is good on power rail 3.
4	LOAD4	Capture the output of f(1) ACMP from an analog pin connected to power rail 4 as defined by the LOAD4 register. A "1" means that power is good on power rail 4.
5	AND	LOAD4 result ANDs with LOAD3 result (LOAD4 & LOAD3). This combines two of the Power Good signals.
6	AND	(LOAD4 & LOAD3) & LOAD2. This combines three of the Power Good signals.
7	AND	((LOAD4 & LOAD3) & LOAD2) & LOAD1. This combines four of the Power Good signals.
8	OUT1	Output the Master Power Good signal to a location defined by the OUT1 register.

The LOADx, OUTx, and DELAY/LWD commands are required to be defined before using them.

17.5.1 Delay Command Configuration Bits

The Delay Command is defined by 12 bits. Each of the 4 instances of the f(1) command can configure a new value for the delays. However, the DELAY and LWD use the same configuration data, so these two delays must be identical.

GreenPAK Programmable Mixed-Signal Matrix with Asynchronous State Machine and Dual Supply

Delay Configuration Bits

Configuration Bits	Description	
8 Bits	Delay Count (0 .. 255)	
3 Bits	Delay Clock	
	000	OSC2
	001	OSC2/4
	010	OSC1
	011	OSC1/8
	100	OSC1/64
	101	OSC0
	110	OSC0/8
	111	OSC0/64
1 Bit	ACMP Shutdown during Delay	ACMP is shutdown after data Load

17.5.2 LOADx Command Configuration Bits

There are two types of load configuration schemes. One method defines loading from one of eight analog pins via the f(1) ACMP. The other method defines loading from any of the matrix outputs connected to digital input pins, logic macrocells, ASM outputs, oscillators, and others. LOAD1 and LOAD2 can only be configured for 4 analog input pins. LOAD3 and LOAD 4 can be configured for the remaining 4 analog input pins.

LOAD1, 2, 3, 4 Command from f(1) ACMP or Matrix connection. A single bit determines if LOADx takes its value from the f(1) analog comparator or from a matrix output.

Configuration Bit	Description	
1 Bit	LOAD1 Connection	0: Matrix, 1: f(1) ACMP
1 Bit	LOAD2 Connection	0: Matrix, 1: f(1) ACMP
1 Bit	LOAD3 Connection	0: Matrix, 1: f(1) ACMP
1 Bit	LOAD4 Connection	0: Matrix, 1: f(1) ACMP

LOAD1 and LOAD2 Configuration Bits f(1) ACMP input.

Configuration Bits	Description	
6 Bits	ACMP Voltage Reference value	000000 is 32 mV, 111111 is 2.048 V
2 Bits	One of four analog input pins	
	00	Analog pin 1
	01	Analog pin 2
	10	Analog pin 3
	11	Analog pin 4
1 Bit	Reserved	

GreenPAK Programmable Mixed-Signal Matrix with Asynchronous State Machine and Dual Supply

LOAD3 and LOAD4 Configuration Bits f(1) ACMP input.

Configuration Bits	Description	
6 Bits	ACMP Voltage Reference value	000000 is 32 mV, 111111 is 2.048 V
2 Bits	One of four analog input pins	
	00	Analog pin 5
	01	Analog pin 6
	10	Analog pin 7
1 Bit	11	Analog pin 8
	Reserved	

17.5.3 OUTx Command Configuration Bits

Each f(1) instance can be configured to output to up to three matrix inputs using the OUTx command. OUT1, 2, & 3's initial condition is two bit selectable. Each time the ASM changes state, the initial condition of the f(1) is re-loaded.

Configuration Bits	Description	
00	OUTx equals previous OUTx	
01	OUTx is 0	
10	OUTx is 1	
11	none (high Z)	

The only time the f(1) Computation Macrocell will run is when ASM macrocell first enters a new state. At that point in time, the f(1) Computation Macrocell will execute the user selected commands (based on user selection), and then relinquish control back to the ASM macrocell. During the time that the f(1) Computation Macrocell is active, there can be no activity in the ASM macrocell (i.e. no ASM macrocell state change).

The f(1) Computation Macrocell has two digital inputs, ASM_nReset and f1_Interrupt. An active signal on either of these inputs will immediately halt any command execution for the f(1) Computation Macrocell, and will immediately relinquish control back to the ASM macrocell.

17.5.4 LOOP WITH DELAY Configuration Bits

There is one conditional command LOOP WITH DELAY (LWD) in f(1) computation macrocell. The order of the f(1) command execution depends on the LWD usage and its configuration. If top value in 1 x 16 memory stack is 0, then the f(1) is delayed according to the configuration of the f(1) delay function and the f(1) command sequence starting from the location defined by 4-bit register is executed, otherwise f(1) continues to execute commands one by one.

Configuration Bits	Description	
4 bits	Next command location after LWD command	0000 is the first command in the f(1) sequence, 1011 is the twelfth last command in the f(1) sequence

GreenPAK Programmable Mixed-Signal Matrix with Asynchronous State Machine and Dual Supply

Example #3: Rising Edge Deglitch Application showing the command sequence for a potential use case of the f(1) Macrocell.

f(1) Command Sequence	Command	Description
1	LOAD1	Capture the output of a pin or any macrocell output defined by the LOAD1 register.
2	DELAY	Delay for the time defined by configuration register.
3	LOAD1	Capture the output of a pin or any macrocell output defined by the LOAD1 register.
4	DELAY	Delay for time defined by configuration register.
5	LOAD1	Capture the output of a pin or any macrocell output defined by the LOAD1 register.
6	AND	Logically AND the top two values of the 1x16 memory stack, that was loaded before (LOAD1 & LOAD1 after Delay).
7	AND	(LOAD1 & LOAD1 after Delay) & LOAD1 after double Delay.
8	LWD	If the calculated value is 0, then start to execute first command once again, which is defined by the configuration bits. Otherwise f(1) continues to execute next command (command 9).
9	OUT1	Output the result value, which is a high level.
10	END	ASM can act on any other signals.

The following flowchart shows the f(1) rising edge deglitch based on three samples application.

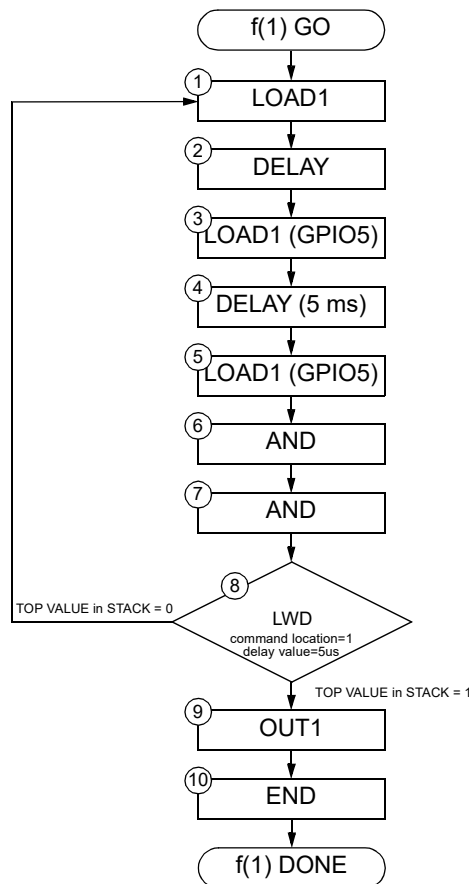

Figure 128: f(1) Flowchart for Rising Edge Deglitch

GreenPAK Programmable Mixed-Signal Matrix with Asynchronous State Machine and Dual Supply

Example #4: Average Function for Captured Data, showing the command sequence for a potential use case of the f(1) Macrocell. This function requires two f(1) Macrocell command sequences to implement.

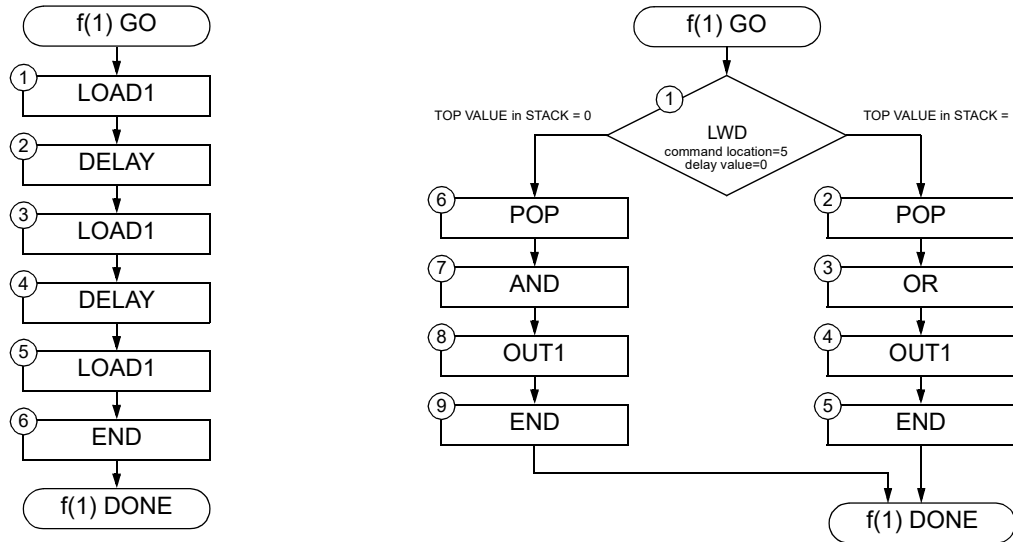

Figure 129: f(1) Flowchart for Average Function for Captured Data

GreenPAK Programmable Mixed-Signal Matrix with Asynchronous State Machine and Dual Supply

17.6 F(1) TYPICAL PERFORMANCE

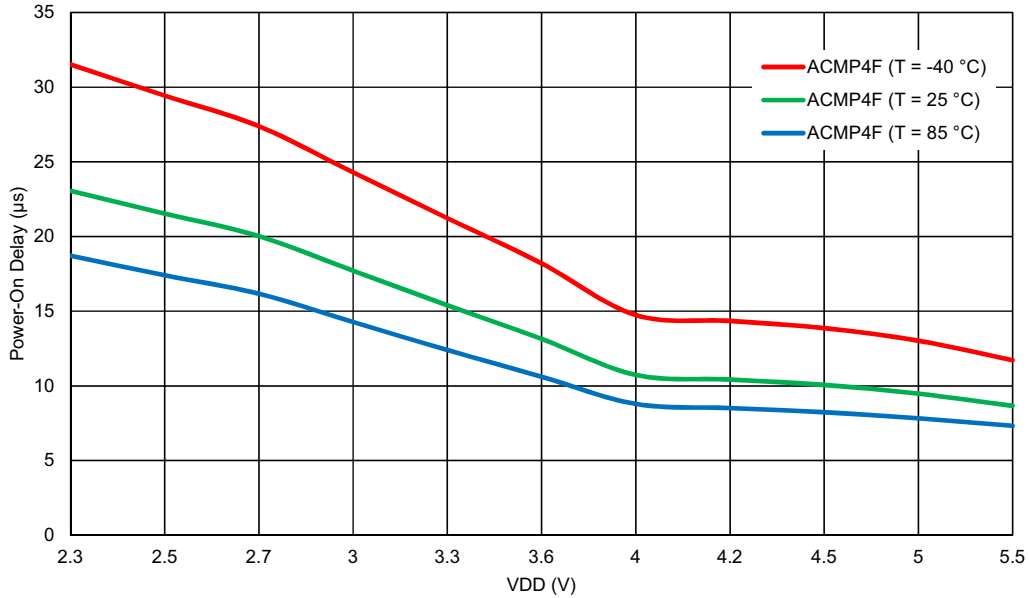

Figure 130: ACMP4F Power-On Delay vs. V_{DD}

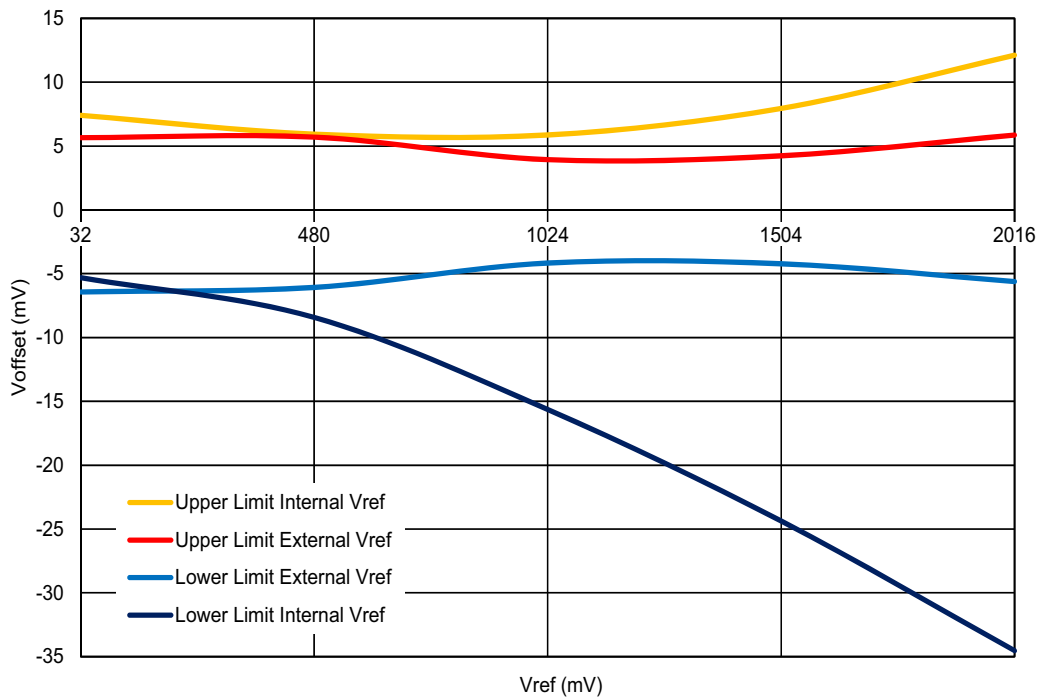

Figure 131: ACMP4F Input Offset Voltage vs. V_{ref} at T = -40 °C to 85 °C, Input Buffer Disabled

GreenPAK Programmable Mixed-Signal Matrix with Asynchronous State Machine and Dual Supply

18 Matrix Interface Macrocells

The ASM Sub-System includes several discrete macrocells, including the ASM macrocell, four Dynamic Memory (DMx_x) macrocells, three Matrix Interface (MI) Macrocells, and one f(1) Computation Macrocell. These macrocells are designed to work as a system for building user defined state machines.

The Matrix Interface macrocells have the characteristic that they can change internal configuration characteristics and their connections to the Connection Matrix based on the current state of the State Machine (SM) macrocell. This is accomplished by making different memory register bit settings contained within the macrocell active, based on the current active state of the SM. This allows the user to “repurpose” the resources inside these macrocells to match the circuit needs in various states.

The SLG46880/81 has a total of three MI macrocells, MI0, MI1, and MI2.

Each MI macrocell has a Mlx Configuration Register Table, which is a bank of 4 Mlx Configuration Registers. The bits in these registers hold user selections which define the input connections from the Connection Matrix. The fact that there are 4 Configuration Registers means that there can only be a total of four unique configurations for each Mlx macrocell. There are a total of twelve states, which means that the user can either re-use the configuration coded in a particular Mlx Operating Mode Register in more than one state, or not use some Mlx macrocells in some states.

Each MI macrocell has a Mlx Operating Mode Selection Table, which is a bank of 12 Configuration Selection Registers, one for each state of the State Machine macrocell. The bits in these registers hold the user’s selection of MI functional behavior (input selection from Connection Matrix), by mapping to a particular selection in the Configuration Register Table, based on the current state of the State Machine macrocell.

18.1 MI0, MI1, AND MI2 MACROCELL ARCHITECTURE

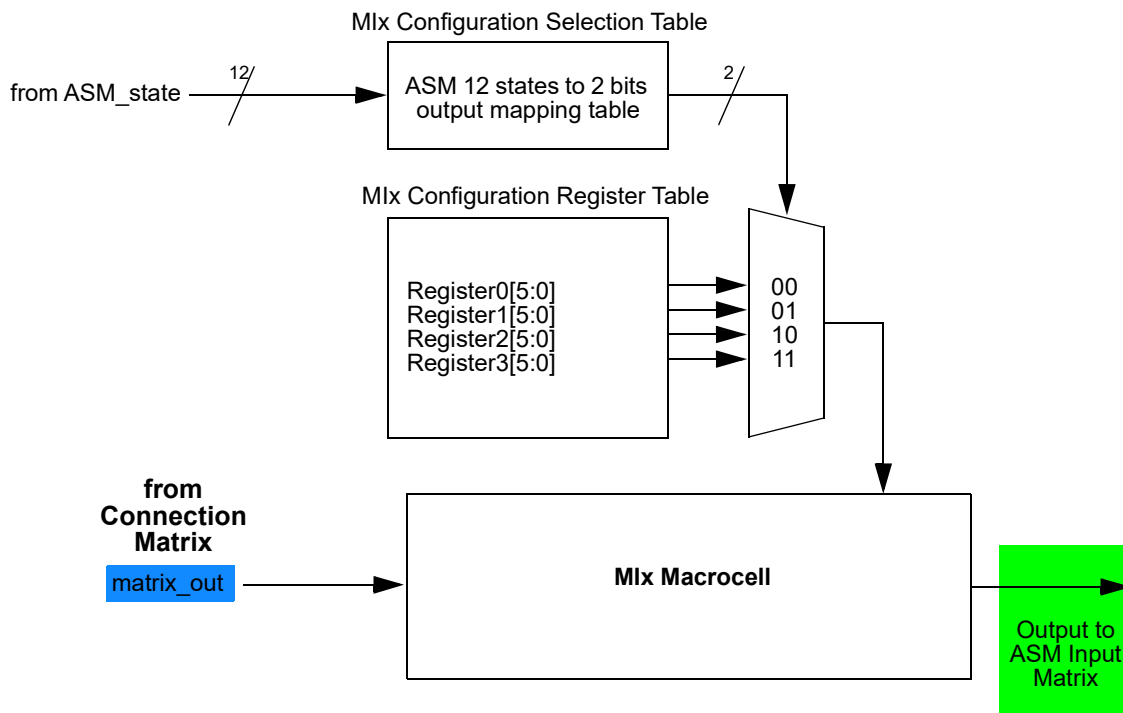

Figure 132: Mlx Macrocell Architecture

GreenPAK Programmable Mixed-Signal Matrix with Asynchronous State Machine and Dual Supply

18.2 MIX MACROCELL INPUT SIGNALS

Each Mix macrocell has a single digital input signal coming from the Connection Matrix and from there can be routed to other internal macrocells or pins. This signal is shown in [Figure 132](#), highlighted in blue.

18.3 MIX MACROCELL OUTPUT SIGNALS

Each Mix macrocell has a single digital output signal, which goes directly to the ASM Input Matrix inside the ASM Macrocell. This signal is shown in [Figure 132](#), highlighted in green.

19 I²C Serial Communications Macrocell

19.1 I²C SERIAL COMMUNICATIONS MACROCELL OVERVIEW

In the standard use case for the GreenPAK devices, the configuration choices made by the user are stored as bit settings in the Non-Volatile Memory (NVM), and this information is transferred at startup time to volatile RAM registers that enable the configuration of the macrocells. Other RAM registers in the device are responsible for setting the connections in the Connection Matrix to route signals in the manner most appropriate for the user's application.

The I²C Serial Communications Macrocell in this device allows an I²C bus Master to read and write this information via a serial channel directly to the RAM registers, allowing the remote re-configuration of macrocells, and remote changes to signal chains within the device.

An I²C bus Master is also able read and write other register bits that are not associated with NVM memory. As an example, the input lines to the Connection Matrix can be read as digital register bits. These are the signal output of each of the macrocells in the device, giving an I²C bus Master the capability to remotely read the current value of any macrocell.

The user has the flexibility to control read access and write access via registers bits registers [4071:4069]. See Section 19.5 for more details on I²C read/write memory protection.

19.2 I²C SERIAL COMMUNICATIONS DEVICE ADDRESSING

Each command to the I²C Serial Communications macrocell begins with a Control Byte. The bits inside this Control Byte are shown in Figure 133. After the Start bit, the first four bits are a control code, which can be set by the user in registers [4083:4080] or value defined externally by GPIs 4, 5, 6, and 7. The LSB of the control code is defined by the value of GPI4, while the MSB is defined by the value of GPI7. The address source is selected by register [4087]. This gives the user flexibility on the chip level addressing of this device and other devices on the same I²C bus. The Block Address is the next three bits (A10, A9, A8), which will define the most significant bits in the addressing of the data to be read or written by the command. The last bit in the Control Byte is the R/W bit, which selects whether a read command or write command is requested, with a "1" selecting for a Read command, and a "0" selecting for a Write command. This Control Byte will be followed by an Acknowledge bit (ACK), which is sent by this device to indicate successful communication of the Control Byte data.

In the I²C-bus specification and user manual, there are two groups of eight addresses (0000 xxx and 1111 xxx) that are reserved for the special functions, such as a system General Call address. If the user of this device chooses to set the Control Code to either "1111" or "0000" in a system with other slave device, please consult the I²C-bus specification and user manual to understand the addressing and implementation of these special functions, to insure reliable operation.

In the read and write command address structure, there are a total of 11 bits of addressing, each pointing to a unique byte of information, resulting in a total address space of 2K bytes. Of this 2K byte address space, the valid addresses accessible to the I²C Macrocell on the SLG46880/81 are in the range from 0 (00H) to 511 (1FFH). The upper two address bits (A10 and A9) will be "0" for all commands to the SLG46880/81. The value of Address bit A8 will depend on whether the Bus Master is addressing the upper or lower half of the 4K bit address space.

With the exception of the Current Address Read command, all commands will have the Control Byte followed by the Word Address.

GreenPAK Programmable Mixed-Signal Matrix with Asynchronous State Machine and Dual Supply

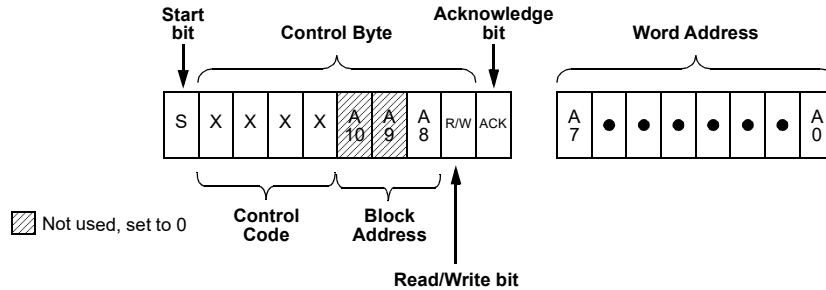

Figure 133: Basic Command Structure

19.3 I²C SERIAL GENERAL TIMING

General timing characteristics for the I²C Serial Communications macrocell are shown in Figure 134. Timing specifications can be found in the AC Characteristics section.

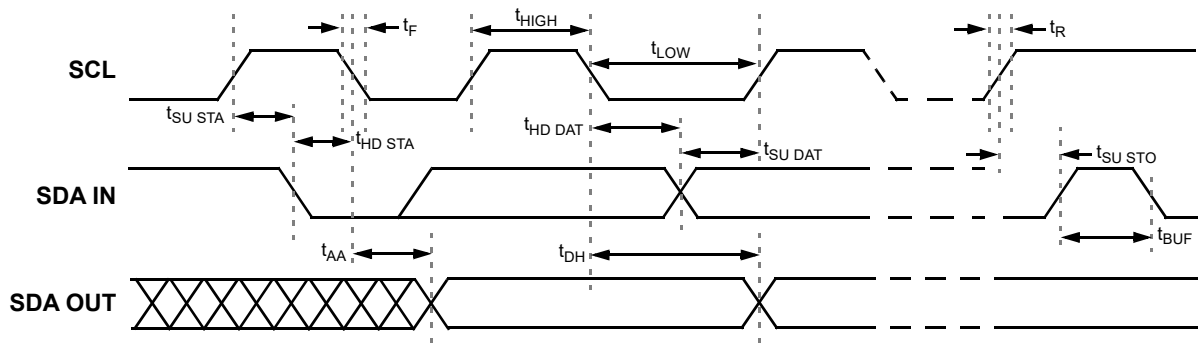

Figure 134: I²C General Timing Characteristics

19.4 I²C SERIAL COMMUNICATIONS COMMANDS

19.4.1 Byte Write Command

Following the Start condition from the Master, the Control Code [4 bits], the Block Address [3 bits], and the R/W bit (set to “0”) are placed onto the I²C bus by the Master. After the SLG46880/81 sends an Acknowledge bit (ACK), the next byte transmitted by the Master is the Word Address. The Block Address (A10, A9, A8), combined with the Word Address (A7 through A0), together set the internal address pointer in the SLG46880/81, where the data byte is to be written. After the SLG46880/81 sends another Acknowledge bit, the Master will transmit the data byte to be written into the addressed memory location. The SLG46880/81 again provides an Acknowledge bit and then the Master generates a Stop condition. The internal write cycle for the data will take place at the time that the SLG46880/81 generates the Acknowledge bit.

It is possible to latch all IOs during I²C write command, register [4065] = 1 - Enable. It means that IOs will remain their state until the write command is done.

GreenPAK Programmable Mixed-Signal Matrix with Asynchronous State Machine and Dual Supply

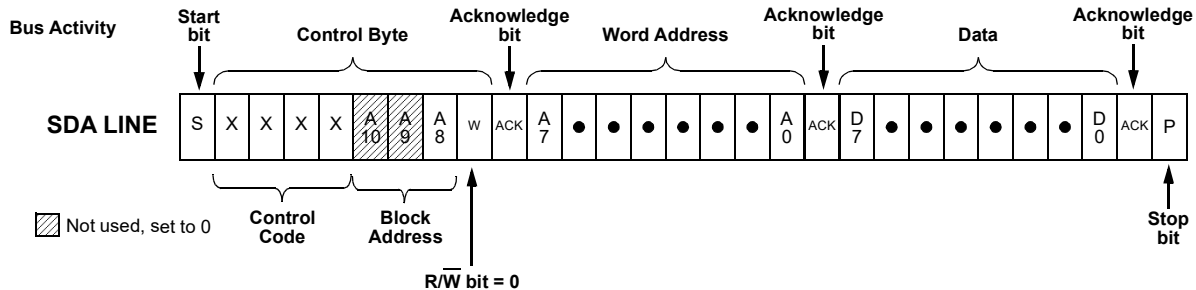

Figure 135: Byte Write Command, $\overline{R/W} = 0$

19.4.2 Sequential Write Command

The write Control Byte, Word Address, and the first data byte are transmitted to the SLG46880/81 in the same way as in a Byte Write command. However, instead of generating a Stop condition, the Bus Master continues to transmit data bytes to the SLG46880/81. Each subsequent data byte will increment the internal address counter, and will be written into the next higher byte in the command addressing. As in the case of the Byte Write command, the internal write cycle will take place at the time that the SLG46880/81 generates the Acknowledge bit.

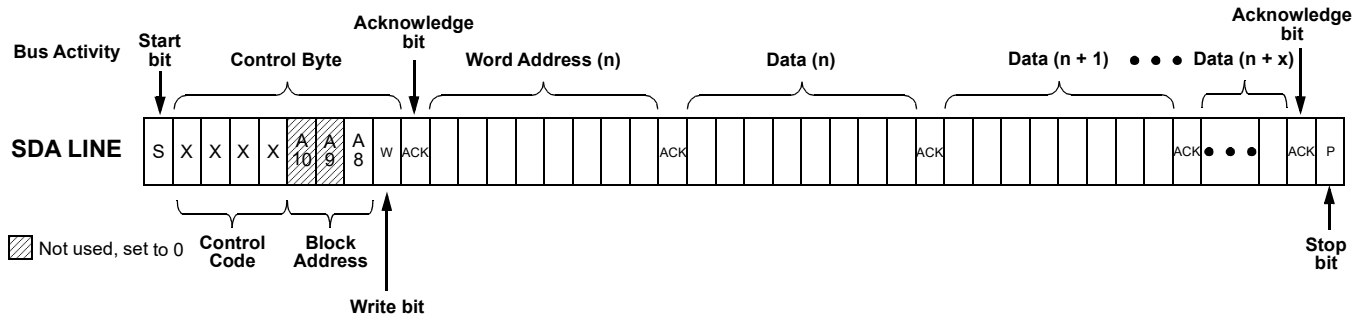

Figure 136: Sequential Write Command

19.4.3 Current Address Read Command

The Current Address Read Command reads from the current pointer address location. The address pointer is incremented at the first STOP bit following any write control byte. For example, if a Sequential Read command (which contains a write control byte) reads data up to address n, the address pointer would get incremented to n + 1 upon the STOP of that command. Subsequently, a Current Address Read that follows would start reading data at n + 1. The Current Address Read Command contains the Control Byte sent by the Master, with the R/W bit = "1". The SLG46880/81 will issue an Acknowledge bit, and then transmit eight data bits for the requested byte. The Master will not issue an Acknowledge bit, and follow immediately with a Stop condition.

GreenPAK Programmable Mixed-Signal Matrix with Asynchronous State Machine and Dual Supply

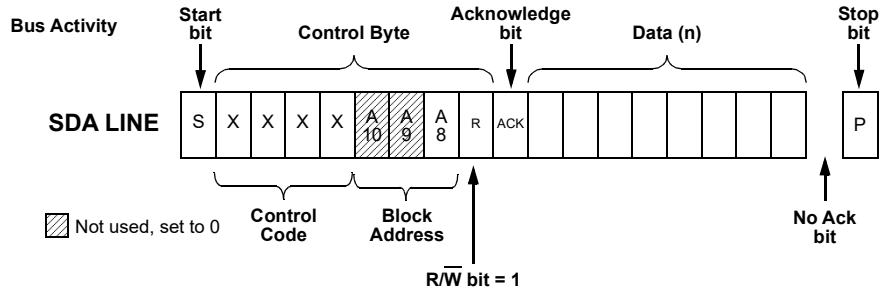

Figure 137: Current Address Read Command, $R/\bar{W} = 1$

19.4.4 Random Read Command

The Random Read command starts with a Control Byte (with R/W bit set to “0”, indicating a write command) and Word Address to set the internal byte address, followed by a Start bit, and then the Control Byte for the read (exactly the same as the Byte Write command). The Start bit in the middle of the command will halt the decoding of a Write command, but will set the internal address counter in preparation for the second half of the command. After the Start bit, the Bus Master issues a second control byte with the R/W bit set to “1”, after which the SLG46880/81 issues an Acknowledge bit, followed by the requested eight data bits.

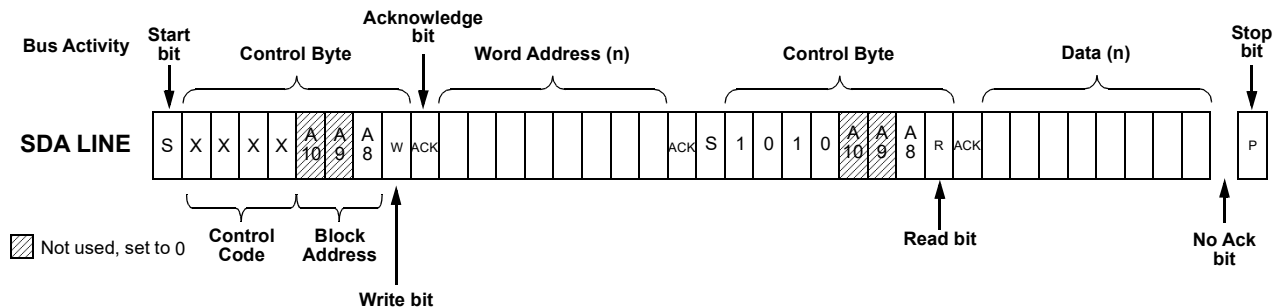

Figure 138: Random Read Command

GreenPAK Programmable Mixed-Signal Matrix with Asynchronous State Machine and Dual Supply

19.4.5 Sequential Read Command

The Sequential Read command is initiated in the same way as a Random Read command, except that once the SLG46880/81 transmits the first data byte, the Bus Master issues an Acknowledge bit as opposed to a Stop condition in a random read. The Bus Master can continue reading sequential bytes of data, and will terminate the command with a Stop condition.

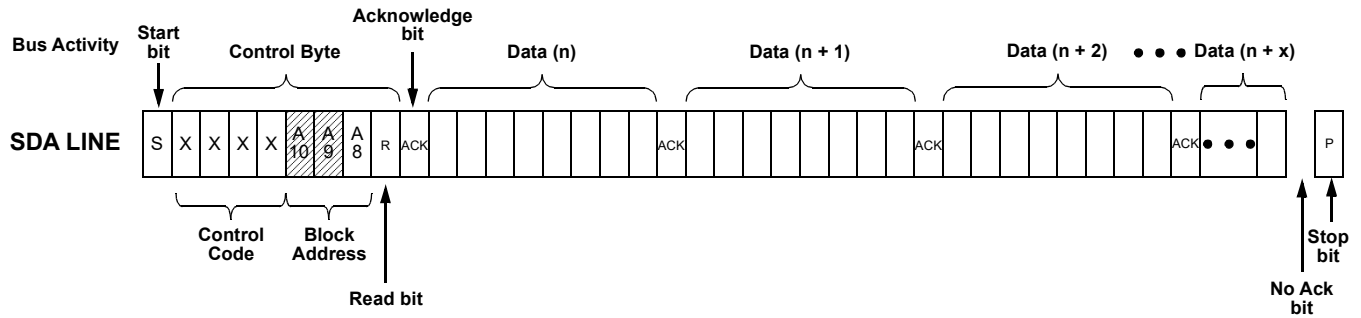

Figure 139: Sequential Read Command

19.4.6 I²C Serial Reset Command

If I²C serial communication is established with the device, it is possible to reset the device to initial power up conditions, including configuration of all macrocells, and all connections provided by the Connection Matrix. This is implemented by setting register [4064] I²C reset bit to “1”, which causes the device to re-enable the Power-On Reset (POR) sequence, including the reload of all register data from NVM. During the POR sequence, the outputs of the device will be in tri-state. After the reset has taken place, the contents of register [4064] will be set to “0” automatically. The timing diagram shown below illustrates the sequence of events for this reset function.

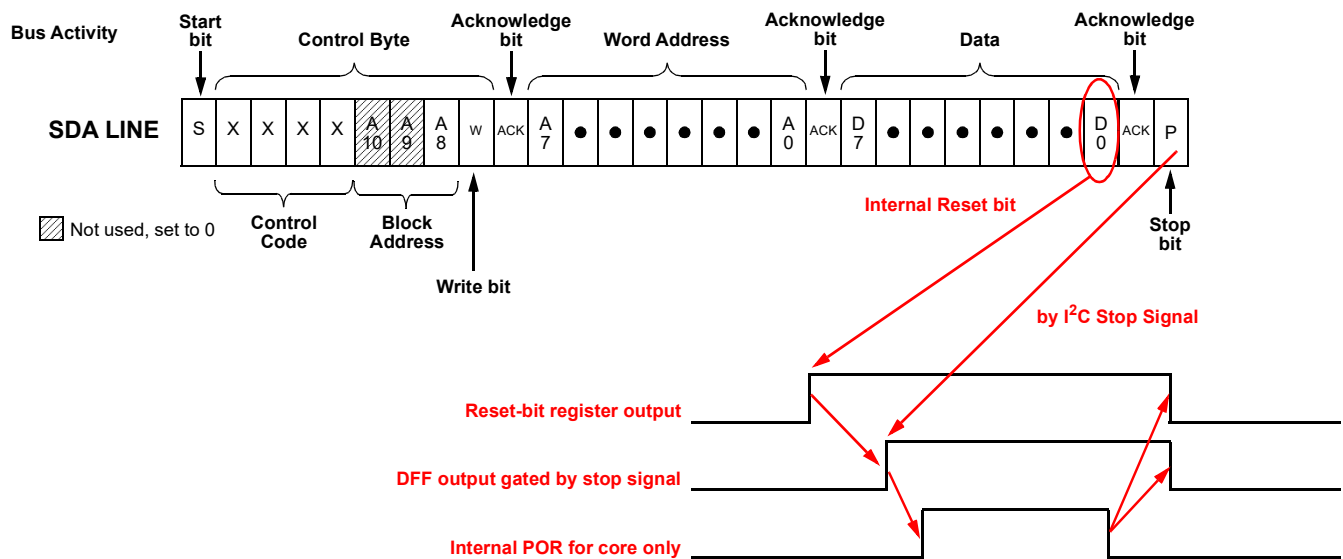

Figure 140: Reset Command Timing

GreenPAK Programmable Mixed-Signal Matrix with Asynchronous State Machine and Dual Supply

19.5 I²C SERIAL COMMAND REGISTER MAP

There are seven read/write protect modes for the design sequence from being corrupted or copied. See [Table 54](#) for details.

Table 54: Read/Write Protection Options

Configurations	Protection Modes Configuration							Data Output From	Register Address
	Unlocked	Partly Lock Read1	Partly Lock Read2	Partly Lock Read2/Write	Lock Read	Lock Write	Lock Read/Write		
	(Mode 0)	(Mode 1)	(Mode 2)	(Mode 3)	(Mode 4)	(Mode 5)	(Mode 6)		
I ² C Byte Write Bit Masking (section 19.6.4)	R/W	R/W	R/W	R/W	W	R	-	Memory	1FD
I ² C Serial Reset Command (section 19.4.6)	R/W	R/W	R/W	R/W	W	R	-	Memory	1FC,b'0
Outputs Latching During I ² C Write	R/W	R/W	R/W	R/W	W	R	-	Memory	1FC,b'1
f(1) Computation Macrocell Stack	R/W	R/W	R/W	R/W	W	R	-	Macrocell	198~199
Connection Matrix Virtual Inputs (section 6.3)	R/W	R/W	R/W	R/W	W	R	-	Macrocell	1DB
Configuration Bits for All Macrocells (IO Pins, ACMPs, Combination Function Macrocells, ASM, etc.)	R/W	R/W	W	-	W	R	-	Memory	
Macrocells Inputs Configuration (Connection Matrix Outputs, section 6.2)	R/W	W	W	-	W	R	-	Memory	0~3E
Protection Mode Selection	R/W	R	R	R	R	R	R	Memory	1FC,b'7,6,5
Macrocells Output Values (Connection Matrix Inputs, section 6.1)	R	R	R	R	-	R	-	Macrocell	1D7~1DA; 1DC~1DE
Counter Current Value	R	R	R	R	-	R	-	Macrocell	1DF,1E0,1E1,1E2
ASM Current State	R	R	R	R	-	R	-	Macrocell	1E3,1E4
I ² C Control Code (section 19.4)	R	R	R	R	R	R	R	Memory	1FE,b'3~0
I ² C Disable/Enable	R	R	R	R	R	R	R	Memory	1FE,b'4

R/W	Allow Read and Write Data
W	Allow Write Data Only
R	Allow Read Data Only

GreenPAK Programmable Mixed-Signal Matrix with Asynchronous State Machine and Dual Supply

-	The Data is protected for Read and Write
---	--

It is possible to read some data from macrocells, such as counter current value, ASM current state, connection matrix, f(1) computation macrocell stack, and connection matrix virtual inputs. The I²C write will not have any impact on data in case data comes from macrocell output, except f(1) Computation Macrocell Stack and Connection Matrix Virtual Inputs. The silicon identification service bits allows identifying silicon family, its revision, and others.

See Section 21 for detailed information on all registers.

19.6 I²C ADDITIONAL OPTIONS

When Output latching during I²C write, register [4065] = 1 allows all PINs output value to be latched until I²C write is done. It will protect the output change due to configuration process during I²C write in case multiple register bytes are changed. Inputs and internal macrocells retain their status during I²C write.

If the user sets GPIO0 and GPIO1 function to a selection other than SDA and SCL, all access via I²C will be disabled.

Note: Any write commands that come to the device via I²C that are not blocked, based on the protection bits, will change the contents of the RAM register bits that mirror the NVM bits. These write commands will not change the NVM bits themselves, and a POR event will restore the register bits to original programmed contents of the NVM.

See Section 21 for detailed information on all registers.

19.6.1 Reading Counter Data via I²C

The current count value in three counters in the device can be read via I²C. The counters that have this additional functionality are 16-bit CNT0, and 8-bit counters CNT2 and CNT4.

19.6.2 Reading ASM Current State via I²C

The Current State of the ASM can be read via I²C. There are 12 memory bits located at registers [3875:3864]. Configuration for each Current State can be found in Table 55.

Table 55: ASM Current State Bits Configuration

I ² C Address	Register Bit #	ASM State #	ASM Current State Bits Configuration											
			State 0	State 1	State 2	State 3	State 4	State 5	State 6	State 7	State 8	State 9	State 10	State 11
1E3	3864	State 0	1	0	0	0	0	0	0	0	0	0	0	0
	3865	State 1	0	1	0	0	0	0	0	0	0	0	0	0
	3866	State 2	0	0	1	0	0	0	0	0	0	0	0	0
	3867	State 3	0	0	0	1	0	0	0	0	0	0	0	0
	3868	State 4	0	0	0	0	1	0	0	0	0	0	0	0
	3869	State 5	0	0	0	0	0	1	0	0	0	0	0	0
	3870	State 6	0	0	0	0	0	0	1	0	0	0	0	0
	3871	State 7	0	0	0	0	0	0	0	1	0	0	0	0
1E4	3872	State 8	0	0	0	0	0	0	0	0	1	0	0	0
	3873	State 9	0	0	0	0	0	0	0	0	0	1	0	0
	3874	State 10	0	0	0	0	0	0	0	0	0	0	1	0
	3875	State 11	0	0	0	0	0	0	0	0	0	0	0	1

19.6.3 I²C Expander

GreenPAK Programmable Mixed-Signal Matrix with Asynchronous State Machine and Dual Supply

In addition to the eight Connection Matrix Virtual Inputs, the SLG46880/81 chip has four pins which can be used as an I²C Expander. These four pins are GPIO4, GPIO5, GPIO6, and GPIO7.

Each of these pins can be used as an I²C Expander output or used as a normal pin. Also, each of these four expander outputs have initial state settings which are specified in registers [3880:3870].

GreenPAK Programmable Mixed-Signal Matrix with Asynchronous State Machine and Dual Supply

19.6.4 I²C Byte Write Bit Masking

The I²C macrocell inside SLG46880/81 supports masking of individual bits within a byte that is written to the RAM memory space. This function is supported across the entire RAM memory space. To implement this function, the user performs a Byte Write Command (see Section 19.4.1 for details) on the I²C Byte Write Mask Register (address 0xxH) with the desired bit mask pattern. This sets a bit mask pattern for the target memory location that will take effect on the next Byte Write Command to this register byte. Any bit in the mask that is set to “1” in the I²C Byte Write Mask Register will mask the effect of changing that particular bit in the target register, during the next Byte Write Command. The contents of the I²C Byte Write Mask Register are reset (set to 00h) after the Byte Write Command. If the next command received by the device is not a Byte Write Command, the effect of the bit masking function will be aborted, and the I²C Byte Write Mask Register will be reset with no effect. Figure 141 shows an example of this function.

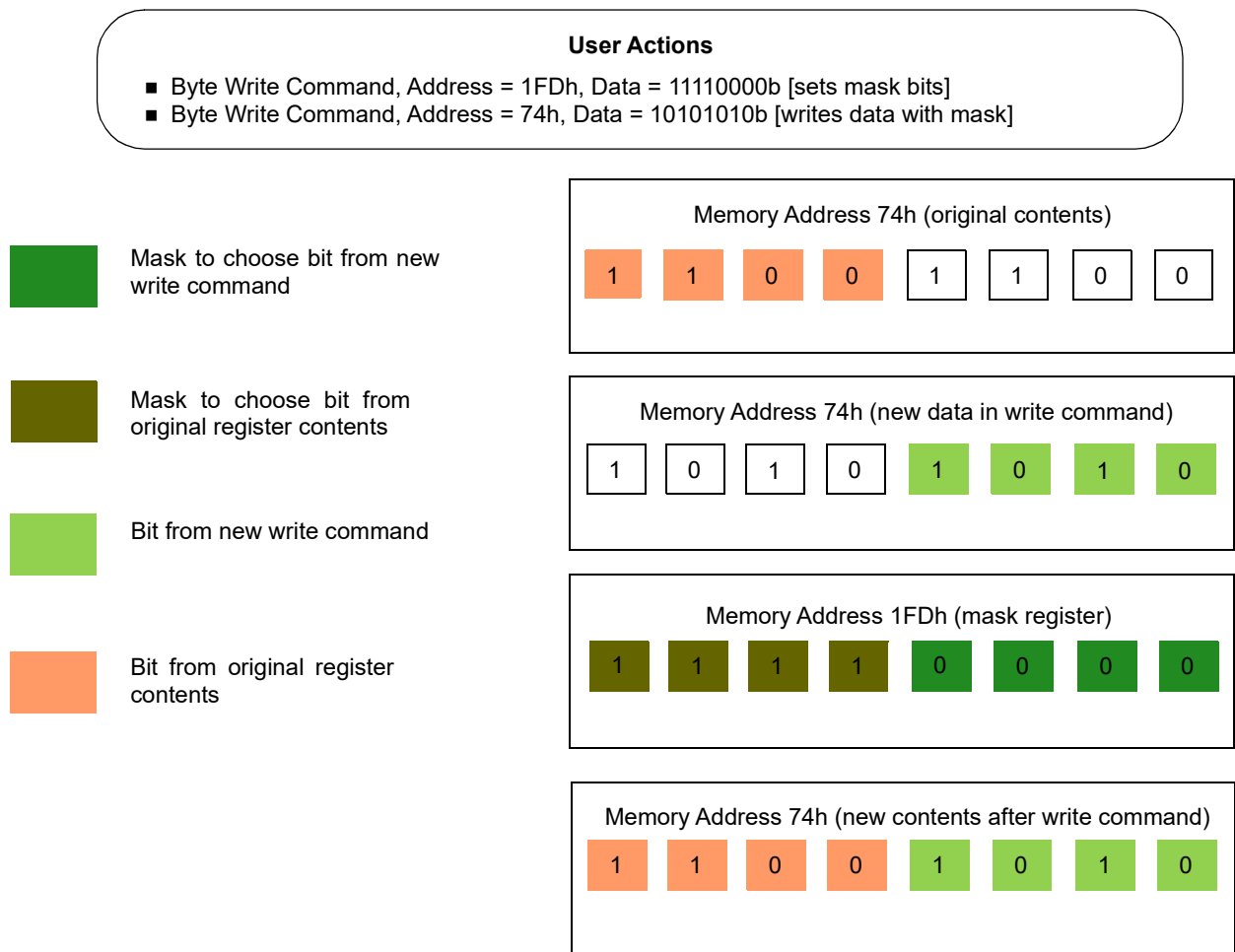

Figure 141: Example of I²C Byte Write Bit Masking

20 Analog Temperature Sensor

The SLG46880 has an Analog Temperature sensor (TS) with an output voltage linearly-proportional to the Centigrade temperature. The TS cell shares buffer with Vref0, so it is impossible to use both cells simultaneously, its output can be connected directly to the GPIO9 or to the ACPM3_L positive input. Using buffer causes low-output impedance, linear output, and makes interfacing to readout or control circuitry especially easy. The TS is rated to operate over a -40 °C to 85 °C temperature range. The error in the whole temperature range does not exceed $\pm 3.6\%$. TS output voltage variation over V_{DD} at constant temperature is less than $\pm 1\%$. For more detail refer to Section 3.

The equation below calculates the typical analog voltage passed from the TS to the ACMPs' IN+ source input. It is important to note that there will be a chip to chip variation of about ± 2 °C.

$$V_{TS1} = -2.3 \times T + 904.6$$

$$V_{TS2} = -2.8 \times T + 1076.1$$

where:

V_{TS1} (mV) - TS Output Voltage, range 1

V_{TS2} (mV) - TS Output Voltage, range 2

T (°C) - Temperature

Temperature hysteresis can be setup by enabling the GreenPAK's internal ACMP hysteresis.

GreenPAK Programmable Mixed-Signal Matrix with Asynchronous State Machine and Dual Supply

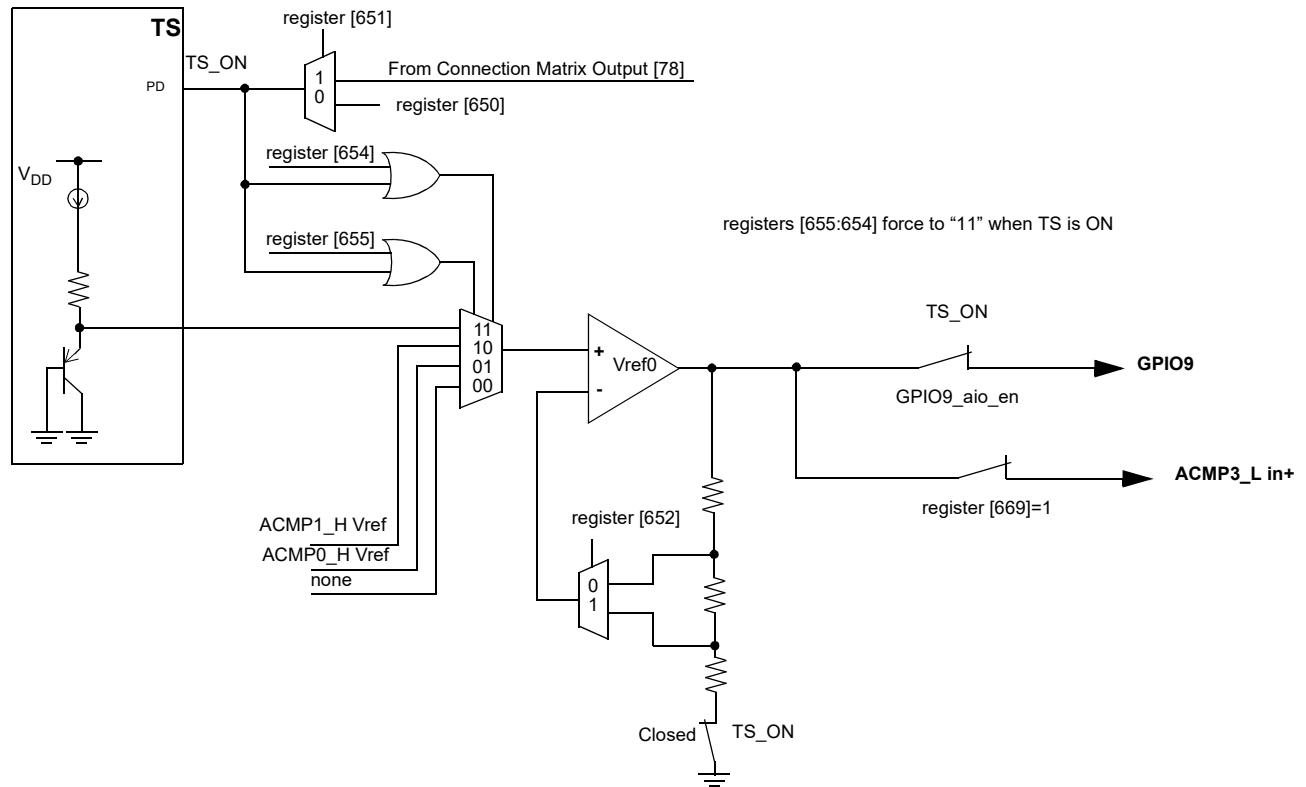

Figure 142: Analog Temperature Sensor Structure Diagram

Note that the Power-Down Mode is paired with Crystal OSC, see Section 12.6. If it is enabled for Temp Sensor, it is not available for Crystal OSC and vice versa. However, it is possible to enable Power-Down Mode for Crystal OSC and Temp Sensor simultaneously.

GreenPAK Programmable Mixed-Signal Matrix with Asynchronous State Machine and Dual Supply

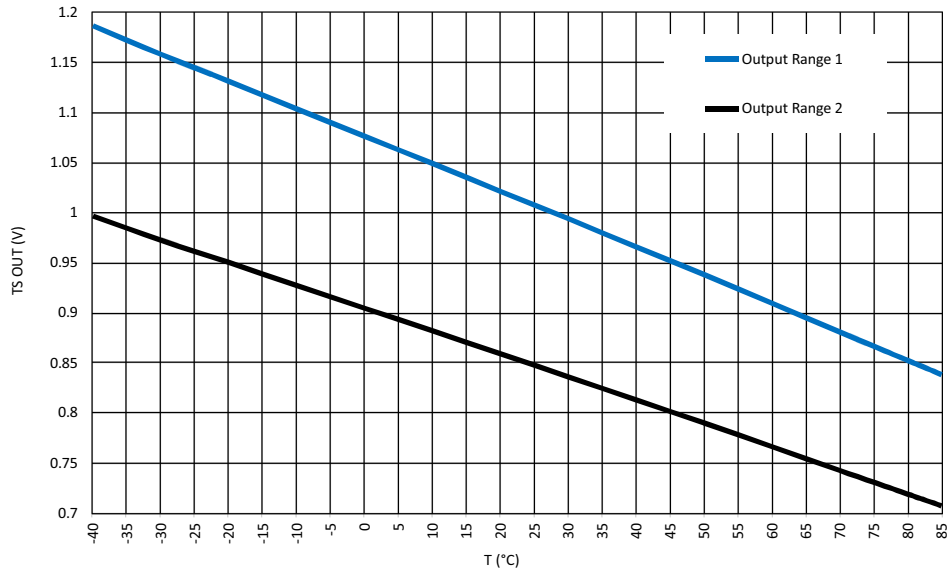

Figure 143: TS Output vs. Temperature, $V_{DD} = 2.3\text{ V to }5.5\text{ V}$

21 Register Definitions

21.1 REGISTER MAP

Table 56: Register Map

Address		Signal Function	Register Bit Definition
Byte	Register Bit		
0	0	OUT0: IN0 of LUT2_0 or Clock Input of DFF0	
	1		
	2		
	3		
	4		
	5		
	6		
1	8	OUT1: IN1 of LUT2_0 or Data Input of DFF0	
	9		
	10		
	11		
	12	OUT2: IN0 of LUT2_1 or Clock Input of PGen	
	13		
	14		
15			
2	16		
	17		
	18	OUT3: IN1 of LUT2_1 or nRST of PGen	
	19		
	20		
	21		
	22		
23			
3	24	OUT4: IN0 of LUT3_0 or Clock Input of DFF1	
	25		
	26		
	27		
	28		
	29		
	30	OUT5: IN1 of LUT3_0 or Data Input of DFF1	
31			
32			
4	33		
	34		
	35		

GreenPAK Programmable Mixed-Signal Matrix with Asynchronous State Machine and Dual Supply

Table 56: Register Map (Continued)

Address		Signal Function	Register Bit Definition	
Byte	Register Bit			
4	36	OUT6: IN2 of LUT3_0 or nRST (nSET) of DFF1		
	37			
	38			
	39			
5	40	OUT7:IN0 of LUT3_1 or Clock Input of DFF2		
	41			
	42			
	43			
	44			
	45			
	46			
6	47	OUT8:IN1 of LUT3_1 or Data Input of DFF2		
	48			
	49			
	50			
	51			
	52			
	53			
7	54	OUT9:IN2 of LUT3_1 or nRST (nSET) of DFF2		
	55			
	56			
	57			
	58			
	59			
	60		OUT10:IN0 of LUT3_2 or Clock Input of DFF3	
61				
62				
63				
8	64	OUT11:IN1 of LUT3_2 or Data Input of DFF3		
	65			
	66			
	67			
	68			
	69			
	70			
	71			

GreenPAK Programmable Mixed-Signal Matrix with Asynchronous State Machine and Dual Supply

Table 56: Register Map (Continued)

Address		Signal Function	Register Bit Definition
Byte	Register Bit		
9	72	OUT12:IN2 of LUT3_2 or nRST (nSET) of DFF3	
	73		
	74		
	75		
	76		
	77		
9	78		
	79		
A	80	OUT13:IN0 of LUT3_3 or Clock Input of DFF4	
	81		
	82		
	83		
	84	OUT14:IN1 of LUT3_3 or Data Input of DFF4	
	85		
	86		
	87		
B	88	OUT15:IN2 of LUT3_3 or nRST (nSET) of DFF4	
	89		
	90		
	91		
	92		
	93		
	94		
	95		

GreenPAK Programmable Mixed-Signal Matrix with Asynchronous State Machine and Dual Supply

Table 56: Register Map (Continued)

Address		Signal Function	Register Bit Definition	
Byte	Register Bit			
C	96	OUT16:IN0 of LUT3_4 or Delay1 Input (or Counter1 nRST Input)		
	97			
	98			
	99			
	100			
	101			
	102			
D	103	OUT17:IN1 of LUT3_4 or External Clock1 Input of Delay1 (or Counter1)		
	104			
	105			
	106			
	107			
	108			
	109			
E	110	OUT18:IN2 of LUT3_4		
	111			
	112			
	113			
	114			
	115			
	116		OUT19:IN0 of LUT3_5 or Delay2 Input (or Counter2 nRST Input)	
	117			
	118			
	119			

GreenPAK Programmable Mixed-Signal Matrix with Asynchronous State Machine and Dual Supply

Table 56: Register Map (Continued)

Address		Signal Function	Register Bit Definition	
Byte	Register Bit			
F	120	OUT20:IN1 of LUT3_5 or External Clock1 Input of Delay2 (or Counter2)		
	121			
	122			
	123			
	124			
	125			
	126			
10	127	OUT21:IN2 of LUT3_5		
	128			
	129			
	130			
	131			
	132		OUT22:IN0 of LUT3_6 or Delay3 Input (or Counter3 nRST Input)	
	133			
11	134	OUT23:IN1 of LUT3_6 or External Clock1 Input of Delay3 (or Counter3)		
	135			
	136			
	137			
	138			
	139			
	140			
12	141	OUT24:IN2 of LUT3_6		
	142			
	143			
	144			
	145			
	146			
	147			
13	148	OUT25:IN0 of LUT3_7 or Delay4 Input (or Counter4 nRST Input)		
	149			
	150			
	151			
	152			
	153			
	154			
	155			

GreenPAK Programmable Mixed-Signal Matrix with Asynchronous State Machine and Dual Supply

Table 56: Register Map (Continued)

Address		Signal Function	Register Bit Definition
Byte	Register Bit		
13	156	OUT26:IN1 of LUT3_7 or External Clock1 Input of Delay4 (or Counter4)	
	157		
	158		
	159		
14	160	OUT27:IN2 of LUT3_7	
	161		
	162		
	163		
	164		
	165		
	166		
	167		
15	168	OUT28:IN0 of LUT3_8 or Input of Pipe Delay or UP signal of Ripple CNT	
	169		
	170		
	171		
	172		
	173		
	174		
16	176	OUT29:IN1 of LUT3_8 or nRST of Pipe Delay or STB of Ripple CNT	
	177		
	178		
	179	OUT30:IN2 of LUT3_8 or Clock of Pipe Delay_Ripple CNT	
	180		
	181		
	182		
17	183	OUT31:IN0 of LUT4_0 or Delay0 Input (or Counter0 nRST Input)	
	184		
	185		
	186		
	187		
	188		
	189		
	190		
	191		

GreenPAK Programmable Mixed-Signal Matrix with Asynchronous State Machine and Dual Supply

Table 56: Register Map (Continued)

Address		Signal Function	Register Bit Definition	
Byte	Register Bit			
18	192	OUT32:IN1 of LUT4_0 or External Clock Input of Delay0 (or Counter0)		
	193			
	194			
	195			
	196			
	197			
	198			
19	199	OUT33:IN2 of LUT4_0 or UP Input of FSM0		
	200			
	201			
	202			
	203			
	204		OUT34:IN3 of LUT4_0 or KEEP Input of FSM0	
	205			
206				
1A	207			
	208	OUT35:PWR UP of ACMP0_H		
	209			
	210			
	211			
	212			
	213			
214				
1B	215	OUT36:PWR UP of ACMP1_H		
	216			
	217			
	218			
	219			
	220			
	221			
1C	222	OUT37:PWR UP of ACMP2_L		
	223			
	224			
	225			
	226			
	227			

GreenPAK Programmable Mixed-Signal Matrix with Asynchronous State Machine and Dual Supply

Table 56: Register Map (Continued)

Address		Signal Function	Register Bit Definition	
Byte	Register Bit			
1C	228	OUT38:PWR UP of ACMP3_L		
	229			
	230			
	231			
1D	232	OUT39: GPO7 DOUT		
	233			
	234			
	235			
	236			
	237			
	238			
1E	240	OUT40: GPO0 DOUT		
	241			
	242			
	243			
	244			
	245			
	246			
1F	248	OUT41: GPIO0 DOUT		
	249			
	250			
	251			
	252		OUT42: GPIO0 DOUT OE	
	253			
	254			
255				
256				
20	257	OUT43: GPIO1 DOUT		
	258			
	259			
	260			
	261			
	262			
	263			

GreenPAK Programmable Mixed-Signal Matrix with Asynchronous State Machine and Dual Supply

Table 56: Register Map (Continued)

Address		Signal Function	Register Bit Definition
Byte	Register Bit		
21	264	OUT44:GPIO1 DOUT OE	
	265		
	266		
	267		
	268		
	269		
	270		
	271		
22	272	OUT45: GPIO2 DOUT	
	273		
	274		
	275		
	276	OUT46: GPIO2 DOUT OE	
	277		
	278		
	279		
23	280	OUT47: GPIO3 DOUT	
	281		
	282		
	283		
	284		
	285		
	286		
	287		

GreenPAK Programmable Mixed-Signal Matrix with Asynchronous State Machine and Dual Supply

Table 56: Register Map (Continued)

Address		Signal Function	Register Bit Definition	
Byte	Register Bit			
24	288	OUT48: GPIO3 DOUT OE		
	289			
	290			
	291			
	292			
	293			
	294			
25	295	OUT49: GPIO4 DOUT		
	296			
	297			
	298			
	299			
	300		OUT50: GPIO4 DOUT OE	
	301			
302				
303				
26	304	OUT51: GPIO5 DOUT		
	305			
	306			
	307			
	308			
	309			
	310			
	311			

GreenPAK Programmable Mixed-Signal Matrix with Asynchronous State Machine and Dual Supply

Table 56: Register Map (Continued)

Address		Signal Function	Register Bit Definition	
Byte	Register Bit			
27	312	OUT52: GPIO5 DOUT OE		
	313			
	314			
	315			
	316			
	317			
	318			
28	319	OUT53: GPO1 DOUT		
	320			
	321			
	322			
	323			
	324		OUT54: GPO2 DOUT	
	325			
326				
29	327	OUT55: GPO3 DOUT		
	328			
	329			
	330			
	331			
	332			
	333			
	334			
	335			

GreenPAK Programmable Mixed-Signal Matrix with Asynchronous State Machine and Dual Supply

Table 56: Register Map (Continued)

Address		Signal Function	Register Bit Definition	
Byte	Register Bit			
2A	336	OUT56: GPO4 DOUT		
	337			
	338			
	339			
	340			
	341			
	342			
2B	343	OUT57: GPIO6 DOUT OE		
	344			
	345			
	346			
	347			
	348		OUT58: GPIO6 DOUT	
	349			
350				
2C	351	OUT59: GPIO7 DOUT		
	352			
	353			
	354			
	355			
	356			
	357			
	358			
	359			

GreenPAK Programmable Mixed-Signal Matrix with Asynchronous State Machine and Dual Supply

Table 56: Register Map (Continued)

Address		Signal Function	Register Bit Definition	
Byte	Register Bit			
2D	360	OUT60: GPIO7 DOUT OE		
	361			
	362			
	363			
	364			
	365			
	366			
2E	367	OUT61: GPIO8 DOUT OE		
	368			
	369			
	370			
	371			
	372		OUT62: GPIO8 DOUT	
	373			
374				
375				
376				
2F	377	OUT63: GPIO9 DOUT OE		
	378			
	379			
	380			
	381			
	382			
	383			

GreenPAK Programmable Mixed-Signal Matrix with Asynchronous State Machine and Dual Supply

Table 56: Register Map (Continued)

Address		Signal Function	Register Bit Definition	
Byte	Register Bit			
30	384	OUT64: GPIO9 DOUT		
	385			
	386			
	387			
	388			
	389			
	390			
31	391	OUT65: GPIO10 DOUT OE		
	392			
	393			
	394			
	395			
	396		OUT66: GPIO10 DOUT	
	397			
398				
32	399	OUT67: GPIO11 DOUT OE		
	400			
	401			
	402			
	403			
	404			
	405			
	406			
407				

GreenPAK Programmable Mixed-Signal Matrix with Asynchronous State Machine and Dual Supply

Table 56: Register Map (Continued)

Address		Signal Function	Register Bit Definition	
Byte	Register Bit			
33	408	OUT68: GPIO11 DOUT		
	409			
	410			
	411			
	412			
	413			
	414			
34	415	OUT69: GPO5 DOUT		
	416			
	417			
	418			
	419			
	420		OUT70: GPO5 DOUT	
	421			
422				
35	423	OUT71: ASM REnSET		
	424			
	425			
	426			
	427			
	428			
	429			
	430			
	431			

GreenPAK Programmable Mixed-Signal Matrix with Asynchronous State Machine and Dual Supply

Table 56: Register Map (Continued)

Address		Signal Function	Register Bit Definition	
Byte	Register Bit			
36	432	OUT72: OSC0 ENABLE		
	433			
	434			
	435			
	436			
	437			
	438			
37	439	OUT73: OSC1 ENABLE		
	440			
	441			
	442			
	443			
	444		OUT74: OSC2 ENABLE	
	445			
446				
447				
38	448	OUT75: Filter/Edge detect input		
	449			
	450			
	451			
	452			
	453			
	454			
	455			

GreenPAK Programmable Mixed-Signal Matrix with Asynchronous State Machine and Dual Supply

Table 56: Register Map (Continued)

Address		Signal Function	Register Bit Definition	
Byte	Register Bit			
39	456	OUT76: F1 interrupt		
	457			
	458			
	459			
	460			
	461			
	462			
3A	463	OUT77: Programmable delay/edge detect input		
	464			
	465			
	466			
	467			
	468		OUT78: Temp sensor/Crystal OSC/Vref Out_0/Vref Out_1 Power Up	
	469			
3B	470	OUT79: GPI LATCH enable		
	471			
	472			
	473			
	474			
	475			
	476			
	477			
	478			
	479			

GreenPAK Programmable Mixed-Signal Matrix with Asynchronous State Machine and Dual Supply

Table 56: Register Map (Continued)

Address		Signal Function	Register Bit Definition	
Byte	Register Bit			
3C	480	OUT80: GPIO LATCH enable		
	481			
	482			
	483			
	484			
	485			
	486			
3D	487	OUT81: BG Power-down		
	488			
	489			
	490			
	491			
	492		OUT82: DM EXT CLK0	
	493			
494				
495				
496				
3E	497	OUT83: DM EXT CLK1		
	498			
	499			
	500			
	501			
	502			
	503			
3F	504	OSC1 turn on by register	when matrix output enable/pd control signal = 0: 0: auto on by delay cells 1: always on	
	505	OSC1 matrix power-down or on select	0: matrix down, and register [504] should set to 1 1: matrix on, and register [504] should set to 0	
	506	external clock source enable	0: internal OSC1 1: external clock from GPI1	
	507	post divider ratio control	00: div 1 01: div 2 10: div 4 11: div 8	
	508			
	509	matrix divider ratio control	000: /1 001: /2 010: /4 011: /3 100: /8 101: /12 110: /24 111: /64	
	510			
511				

GreenPAK Programmable Mixed-Signal Matrix with Asynchronous State Machine and Dual Supply

Table 56: Register Map (Continued)

Address		Signal Function	Register Bit Definition
Byte	Register Bit		
40	512	matrix out enable	0: disable 1: enable
	513	Reserved	
	514	Reserved	
	515	Reserved	
	516	OSC2 turn on by register	when matrix output enable/pd control signal = 0: 0: auto on by delay cells 1: always on
	517	matrix power-down or on select	0: matrix down 1: matrix on
	518	external clock source enable	0: internal OSC2 1: external clock from GPIO
	519	matrix out enable	0: disable 1: enable
41	520	post divider ratio control	00: div 1 01: div 2 10: div 4 11: div 8
	521		
	522	matrix divider ratio control	000: /1 001: /2 010: /4 011: /3 100: /8 101: /12 110: /24 111: /64
	523		
	524		
	525	100 ns Startup Delay	0: enable 1: disable
	526	OSC0 turn on by register	when matrix output enable/pd control signal = 0: 0: auto on by delay cells 1: always on
	527	matrix power-down or on select	0: matrix down 1: matrix on
42	528	external clock source enable	0: internal OSC0 1: external clock from PIN30
	529	matrix out enable	0: disable 1: enable
	530	post divider ratio control	00: div 1 01: div 2 10: div 4 11: div 8
	531		
	532	matrix divider ratio control	000: /1 001: /2 010: /4 011: /3 100: /8 101: /12 110: /24 111: /64
	533		
	534		
	535	Reserved	

GreenPAK Programmable Mixed-Signal Matrix with Asynchronous State Machine and Dual Supply

Table 56: Register Map (Continued)

Address		Signal Function	Register Bit Definition
Byte	Register Bit		
43	536	GPI0 Digital Input 100 ns debounce enable	0: disable 1: enable
	537	GPI1 Digital Input 100 ns debounce enable	0: disable 1: enable
	538	GPI5 Digital Input 100 ns debounce enable	0: disable 1: enable
	539	GPI6 Digital Input 100 ns debounce enable	0: disable 1: enable
	540	Filter or Edge Detector selection	Filter or Edge Detector Select 0: filter 1: edge det
	541	Output Polarity Select	0: Filter/edge detect output 1: Filter/edge detect output inverted
	542	Select the edge mode	00: Rising Edges Det 01: Falling Edge Det 10: Both Edge Det 11: Both Edge dly
543			
44	544	LUT value or pipe delay out sel or Nset/END value	[7:4]: LUT3_8 [7:4]/REG_S1[3:0] pipe delay out1 sel [3:0]: LUT3_8 [3:0]/REG_S0[3:0] pipe delay out0 sel at Ripple CNT mode: bit[546:544] is the nSET value. bit[549:547] is the END value bit [550] is the range control: 0: full cycle, 1: ranged cycle bit [551] Not used
	545		
	546		
	547		
	548		
	549		
	550		
551			
45	552	Pipe Delay OUT1 Polarity Select	0: Non-inverted 1: Inverted
	553	LUT3_8 or Pipe Delay Select	0: LUT3_8 1: Pipe Delay or Ripple CNT
	554	PIPE_Ripple_CNT_S	0: Pipe delay mode selection 1: Ripple Counter mode selection
	555	Reserved	
	556	Select the Edge Mode of Programmable Delay & Edge Detector	00: Rising Edge Detector 01: Falling Edge Detector 10: Both Edge Detector 11: Both Edge Delay
	557		
	558	Delay Value Select for Programmable Delay & Edge Detector	00: 125ns 01: 250ns 10: 375ns 11: 500ns
559			

GreenPAK Programmable Mixed-Signal Matrix with Asynchronous State Machine and Dual Supply

Table 56: Register Map (Continued)

Address		Signal Function	Register Bit Definition		
Byte	Register Bit				
46	560	LUT2_0/DFF0 setting	[3]:LUT2_0 [3]/DFF0 or LATCH Select 0: DFF function 1: LATCH function [2]:LUT2_0 [2]/DFF0 Output Select 0: Q output 1: QB output [1]:LUT2_0 [1]/DFF0 Initial Polarity Select 0: Low 1: High [0]:LUT2_0 [0]		
	561				
	562				
	563				
	564	LUT2_1_VAL or PGen_data	LUT2_1[3:0] or PGen 4bit counter data[3:0]		
	565				
	566				
	567				
47	568	PGen data	PGen Data[15:0]		
	569				
	570				
	571				
	572				
	573				
	574				
	575				
48	576			PGen data	PGen Data[15:0]
	577				
	578				
	579				
	580				
	581				
	582				
	583				
49	584	LUT3_0_DFF1 setting	[7]:LUT3_0 [7]/DFF1 or LATCH Select 0: DFF function 1: LATCH function [6]:LUT3_0 [6]/DFF1 Output Select 0: Q output 1: QB output [5]:LUT3_0 [5]/DFF1 0: nRST from Matrix Output 1: nSET from Matrix Output [4]:LUT3_0 [4]/DFF1 Initial Polarity Select 0: Low, 1: High [3:0]: LUT3_0 [3:0]		
	585				
	586				
	587				
	588				
	589				
	590				
	591				

GreenPAK Programmable Mixed-Signal Matrix with Asynchronous State Machine and Dual Supply

Table 56: Register Map (Continued)

Address		Signal Function	Register Bit Definition
Byte	Register Bit		
4A	592	LUT3_1_DFF2 setting	[7]:LUT3_1 [7]/DFF2 or LATCH Select 0: DFF function 1: LATCH function
	593		[6]:LUT3_1 [6]/DFF2 Output Select
	594		0: Q output 1: QB output
	595		[5]:LUT3_1 [5]/DFF2
	596		0: nRST from Matrix Output 1: nSET from Matrix Output
	597		[4]:LUT3_1 [4]/DFF2 Initial Polarity Select
	598		0: Low 1: High
	599	[3:0]: LUT3_1 [3:0]	
4B	600	LUT3_2_DFF3 setting	[7]:LUT3_2 [7]/DFF3 or LATCH Select 0: DFF function, 1: LATCH function
	601		[6]:LUT3_2 [6]/DFF3 Output Select
	602		0: Q output 1: QB output
	603		[5]:LUT3_2 [5]/DFF3
	604		0: nRST from Matrix Output 1: nSET from Matrix Output
	605		[4]:LUT3_2 [4]/DFF3 Initial Polarity Select
	606		0: Low 1: High [
	607	3:0]: LUT3_2 [3:0]	
4C	608	LUT3_3_DFF4 setting	[7]:LUT3_3 [7]/DFF4 or LATCH Select 0: DFF function 1: LATCH function
	609		[6]:LUT3_3 [6]/DFF4 Output Select
	610		0: Q output 1: QB output
	611		[5]:LUT3_3 [5]/DFF4
	612		0: nRST from Matrix Output 1: nSET from Matrix Output
	613		[4]:LUT3_3 [4]/DFF4 Initial Polarity Select
	614		0: Low 1: High
	615	[3:0]: LUT3_3 [3:0]	

GreenPAK Programmable Mixed-Signal Matrix with Asynchronous State Machine and Dual Supply

Table 56: Register Map (Continued)

Address		Signal Function	Register Bit Definition	
Byte	Register Bit			
4D	616	LUT2_0 or DFF0 Select	0: LUT2_0 1: DFF0	
	617	LUT2_1 or PGen Select	0: LUT2_1 1: PGen	
	618	LUT3_0 or DFF1 Select	0: LUT3_0 1: DFF1	
	619	DFF1_SECONDQ_Sel	0: Q of first DFF 1 Q of second DFF	
	620	LUT3_1 or DFF2 Select	0: LUT3_1 1: DFF2	
	621	LUT3_2 or DFF3 Select	0: LUT3_2 1: DFF3	
	622	LUT3_3 or DFF4 Select	0: LUT3_3 1: DFF4	
	623	Reserved		
4E	624	BG CHOP OFF	0: CHOP enable 1: chopper off	
	625	BG Chopper clock test enable	1: enable	
	626	Bandgap internal voltage output to Pin enable	1: enable	
	627	ACMP0_H hysteresis	00: 0 mV 01: 32 mV 10: 64 mV 11: 192 mV	
	628			
		629	Reserved	
	630	ACMP0_H input buffer enable	1: enable	
	631	Reserved		
4F	632	ACMP0_H input tie to V _{DD} enable	1: enable	
	633	ACMP1_H positive input come from AC-MP0_H's input mux output enable	1: enable	
	634	Reserved		
	635	ACMP1_H hysteresis	00: 0 mV 01: 32 mV 10: 64 mV 11: 192 mV	
	636			
		637	ACMP1_H input buffer enable	0: disable 1: enable
		638	Reserved	
	639	ACMP2_L positive input come from AC-MP0_H's input mux output enable	1: enable	

GreenPAK Programmable Mixed-Signal Matrix with Asynchronous State Machine and Dual Supply
Table 56: Register Map (Continued)

Address		Signal Function	Register Bit Definition
Byte	Register Bit		
50	640	ACMP2_L positive input come from AC-MP1_H's input mux output enable	1: enable
	641	ACMP2_L hysteresis	00: 0 mV 01: 32 mV 10: 64 mV 11: 192 mV
	642		
	643	Reserved	
	644	Reserved	
	645	ACMP3_L hysteresis	00: 0 mV 01: 32 mV 10: 64 mV 11: 192 mV
	646		
647	Reserved		
51	648	Reserved	
	649	ACMP3_L positive input come from AC-MP2_L's input mux output enable	1: enable
	650	Temp sensor register pd control	0: Power-down 1: Power-On
	651	Temp sensor register pd select	0: from register 1: from matrix
	652	Temp sensor range select	0: range 1 (0.62 V ~ 0.99 V (TYP)) 1: range 2 (0.75 V ~ 1.2 V (TYP))
	653	Vref0 output OP	0: disable 1: enable
	654	Vref0 input selection	00: None 01: ACMP0_H Vref 10: ACMP1_H Vref 11: temp sensor
655			
52	656	Vref1 output OP	0: disable 1: enable
	657	Vref1 input selection	00: None 01: ACMP2_L Vref 10: ACMP3_L Vref
	658		
	659	Reserved	
	660		
	661		
	662		
663	ACMP0_H Wake/sleep enable	1: enable	

GreenPAK Programmable Mixed-Signal Matrix with Asynchronous State Machine and Dual Supply

Table 56: Register Map (Continued)

Address		Signal Function	Register Bit Definition
Byte	Register Bit		
53	664	ACMP1_H Wake/sleep enable	1: enable
	665	ACMP wake/sleep time selection,	0: short time 1: normal w/s
	666	ACMP0_H 100uA current source enable	1: enable
	667	Reserved for ACMP	
	668	Reserved	
	669	ACMP3_L input come from Temp sensor output enable	1: enable
	670	IO fast Pull-up/down enable	0: disable 1: enable
	671	8 GPO outputs skew enable	0: disable 1: enable

GreenPAK Programmable Mixed-Signal Matrix with Asynchronous State Machine and Dual Supply

Table 56: Register Map (Continued)

Address		Signal Function	Register Bit Definition
Byte	Register Bit		
54	672	GPO7output mode configuration	00: Push-Pull 1x 01: Push-Pull 2x 10: 1x Open-Drain 11: 2x Open-Drain
	673		
	674	GPO7Pull-up/down resistance selection	00: floating 01: 10K 10: 100K 11: 1M
	675		
	676	GPO7Pull-up/down selection	0: Pull-down 1: Pull-up
	677	GPO7digital output source selection	0: from matrix 1: from ASM (ASM output to GPO bit[0])
	678	GPO7output enable	0: disable 1: enable.
	679	GPO0output mode configuration	00: Push-Pull 1x 01: Push-Pull 2x 10: 1x Open-Drain 11: 2x Open-Drain
55	680		
	681		
682	GPO0Pull-up/down resistance selection		00: floating 01: 10K 10: 100K 11: 1M
683	GPO0Pull-up/down selection		0: Pull-down 1: Pull-up
684	GPO0digital output source selection		0: from matrix 1: from ASM (ASM output to GPO bit[1])
685	GPO0output enable		0: disable 1: enable
686	GPIO0 ultra-low power digital in enable (only used in SLG46881)	0: disable 1: enable	
56	687	GPIO0input mode configuration	00: digital without Schmitt Trigger 01: digital with Schmitt Trigger 10: low voltage digital in 11: analog IO
	688		
	689	GPIO0output mode configuration	00: Push-Pull 1x 01: Push-Pull 2x 10: 1x Open-Drain 11: 2x Open-Drain
	690		
	691	GPIO0Pull-up/down resistance selection	00: floating 01: 10K 10: 100K 11: 1M
	692		
	693	GPIO0Pull-up/down selection	0: Pull-down 1: Pull-up
	694	Reserved	
695	GPIO1 ultra-low power digital in enable (only used in SLG46881)	0: disable 1: enable	

GreenPAK Programmable Mixed-Signal Matrix with Asynchronous
 State Machine and Dual Supply

Table 56: Register Map (Continued)

Address		Signal Function	Register Bit Definition
Byte	Register Bit		
57	696	GPIO1input mode configuration	00: digital without Schmitt Trigger
	697		01: digital with Schmitt Trigger
	698	GPIO1output mode configuration	10: low voltage digital in
	699		11: analog IO
	700	GPIO1Pull-up/down resistance selection	00: Push-Pull 1x
	701		01: Push-Pull 2x
	702		10: 1x Open-Drain
	703	GPIO1Pull-up/down selection	11: 2x Open-Drain
58	704	Reserved	00: floating
	705		01: 10K
	706	GPIO2 ultra-low power digital in enable (only used in SLG46881)	10: 100K
	707		11: 1M
	708	GPIO2digital input LATCH configuration	0: Pull-down
	709		1: Pull-up
	710	GPIO2input mode configuration	00: without LATCH
	711		01: normal LATCH
59	712	GPIO2output mode configuration	10: input data 0 LATCH (when LATCH_en is high)
	713		11: input data 1 LATCH (when LATCH_en is high)
	714	GPIO2Pull-up/down resistance selection	00: digital without Schmitt Trigger
	715		01: digital with Schmitt Trigger
	716	GPIO2Pull-up/down selection	10: low voltage digital in
	717		11: analog IO
	718	GPIO0digital input LATCH configuration	00: Push-Pull 1x
	719		01: Push-Pull 2x
719	GPIO0input mode configuration	10: 1x Open-Drain	
719		11: 2x Open-Drain	
719	GPIO0Pull-up/down resistance selection	00: floating	
719		01: 10K	
719	GPIO0Pull-up/down selection	10: 100K	
719		11: 1M	

GreenPAK Programmable Mixed-Signal Matrix with Asynchronous
 State Machine and Dual Supply

Table 56: Register Map (Continued)

Address		Signal Function	Register Bit Definition
Byte	Register Bit		
5A	720	GPI0Pull-up/down selection	0: Pull-down 1: Pull-up
	721	GPI1 ultra-low power digital in enable (only used in SLG46881)	0: disable 1: enable
	722	GPI1digital input LATCH configuration	00: without LATCH 01: normal LATCH 10: input data 0 LATCH (when LATCH_en is high) 11: input data 1 LATCH (when LATCH_en is high)
	723		
	724	GPI1input mode configuration	00: digital without Schmitt Trigger 01: digital with Schmitt Trigger 10: low voltage digital in 11: analog IO
	725		
	726	GPI1Pull-up/down resistance selection	00: floating 01: 10K 10: 100K 11: 1M
	727		
5B	728	GPI1Pull-up/down selection	0: Pull-down 1: Pull-up
	729	GPI2 ultra-low power digital in enable (only used in SLG46881)	0: disable 1: enable
	730	GPI2/SDA input mode configuration	00: digital in without Schmitt Trigger 01: digital in with Schmitt Trigger (when register [4084] = 1) 10: low voltage digital in 11: Reserved
	731		
	732	GPI2/SDA Pull-up/down resistance selection	00: floating 01: 10K 10: 100K 11: 1M
	733		
	734	GPI2/SDAPull-up/down selection	0: Pull-down 1: Pull-up
	735	GPI3 ultra-low power digital in enable (only used in SLG46881)	0: disable 1: enable
5C	736	GPI3/SCL input mode configuration	00: digital in without Schmitt Trigger 01: digital in with Schmitt Trigger (when register [4084] = 1) 10: low voltage digital in 11: Reserved
	737		
	738	GPI3/SCLPull-up/down resistance selection	00: floating 01: 10K 10: 100K 11: 1M
	739		
	740	GPI3/SCLPull-up/down selection	0: Pull-down 1: Pull-up
	741	GPI03 ultra-low power digital in enable (only used in SLG46881)	0: disable 1: enable
	742	GPI03digital input LATCH configuration	00: without LATCH 01: normal LATCH 10: input data 0 LATCH (when LATCH_en is high) 11: input data 1 LATCH (when LATCH_en is high)
	743		

GreenPAK Programmable Mixed-Signal Matrix with Asynchronous
 State Machine and Dual Supply

Table 56: Register Map (Continued)

Address		Signal Function	Register Bit Definition
Byte	Register Bit		
5D	744	GPIO3input mode configuration	00: digital without Schmitt Trigger 01: digital with Schmitt Trigger 10: low voltage digital in 11: analog IO.
	745		
	746	GPIO3output mode configuration	00: Push-Pull 1x 01: Push-Pull 2x 10: 1x Open-Drain 11: 2x Open-Drain
	747		
	748	GPIO3Pull-up/down resistance selection	00: floating 01: 10K 10: 100K 11: 1M
	749		
	750	GPIO3Pull-up/down selection	0: Pull-down 1: Pull-up
	751	Reserved	
5E	752	Reserved	
	753	GPIO4input mode configuration	00: digital without Schmitt Trigger 01: digital with Schmitt Trigger 10: low voltage digital in 11: analog IO
	754		
	755	GPIO4output mode configuration	00: Push-Pull 1x 01: Push-Pull 2x 10: 1x Open-Drain 11: 2x Open-Drain
	756		
	757	GPIO4Pull-up/down resistance selection	00: floating 01: 10K 10: 100K 11: 1M
	758		
	759	GPIO4Pull-up/down selection	0: Pull-down 1: Pull-up
5F	760	Reserved	
	761	GPIO5input mode configuration	00: digital without Schmitt Trigger 01: digital with Schmitt Trigger 10: low voltage digital in 11: analog IO
	762		
	763	GPIO5output mode configuration	00: Push-Pull 1x 01: Push-Pull 2x 10: 1x Open-Drain 11: 2x Open-Drain
	764		
	765	GPIO5Pull-up/down resistance selection	00: floating 01: 10K 10: 100K 11: 1M
	766		
	767	GPIO5Pull-up/down selection	0: Pull-down 1: Pull-up

GreenPAK Programmable Mixed-Signal Matrix with Asynchronous State Machine and Dual Supply

Table 56: Register Map (Continued)

Address		Signal Function	Register Bit Definition
Byte	Register Bit		
60	768	GPO1output mode configuration	00: Push-Pull 1x 01: Push-Pull 2x 10: 1x Open-Drain 11: 2x Open-Drain
	769		
	770	GPO1Pull-up/down resistance selection	00: floating 01: 10K 10: 100K 11: 1M
	771		
	772	GPO1Pull-up/down selection	0: Pull-down 1: Pull-up
	773	GPO1digital output source selection	0: from matrix 1: from ASM (ASM output to GPO bit[2])
	774	GPO1output enable	0: disable 1: enable.
	775	GPO2output mode configuration	00: Push-Pull 1x 01: Push-Pull 2x 10: 1x Open-Drain 11: 2x Open-Drain
776			
61	777	GPO2Pull-up/down resistance selection	00: floating 01: 10K 10: 100K 11: 1M
	778		
	779	GPO2Pull-up/down selection	0: Pull-down 1: Pull-up
	780	GPO2digital output source selection	0: from matrix 1: from ASM (ASM output to GPO bit[3]).
	781	GPO2output enable	0: disable 1: enable.
	782	GPO3output mode configuration	00: Push-Pull 1x 01: Push-Pull 2x 10: 1x Open-Drain 11: 2x Open-Drain
	783		
62	784	GPO3Pull-up/down resistance selection	00: floating 01: 10K 10: 100K 11: 1M
	785		
	786	GPO3Pull-up/down selection	0: Pull-down 1: Pull-up
	787	GPO3digital output source selection	0: from matrix 1: from ASM (ASM output to GPO bit[4]).
	788	GPO3output enable	0: disable 1: enable.
	789	GPO4output mode configuration	00: Push-Pull 1x 01: Push-Pull 2x 10: 1x Open-Drain 11: 2x Open-Drain
	790		
63	791	GPO4Pull-up/down resistance selection	00: floating 01: 10K 10: 100K 11: 1M
	792		

GreenPAK Programmable Mixed-Signal Matrix with Asynchronous State Machine and Dual Supply

Table 56: Register Map (Continued)

Address		Signal Function	Register Bit Definition	
Byte	Register Bit			
63	793	GPO4Pull-up/down selection	0: Pull-down 1: Pull-up	
	794	GPO4digital output source selection	0: from matrix 1: from ASM (ASM output to GPO bit[5]).	
	795	GPO4output enable	0: disable 1: enable.	
	796	Reserved		
	797	GPIO6digital input LATCH configuration	00: without LATCH 01: normal LATCH 10: input data 0 LATCH (when LATCH_en is high) 11: input data 1 LATCH (when LATCH_en is high)	
	798		GPIO6input mode configuration	00: digital without Schmitt Trigger 01: digital with Schmitt Trigger 10: low voltage digital in 11: analog IO.
	799			GPIO6output mode configuration
64	800	GPIO6Pull-up/down resistance selection	00: floating 01: 10K 10: 100K 11: 1M.	
	801		GPIO6Pull-up/down selection	0: Pull-down 1: Pull-up
	802	Reserved		
	803	Reserved		
	804	GPIO7digital input LATCH configuration	00: without LATCH 01: normal LATCH 10: input data 0 LATCH (when LATCH_en is high) 11: input data 1 LATCH (when LATCH_en is high)	
	805		GPIO7input mode configuration	00: digital without Schmitt Trigger 01: digital with Schmitt Trigger 10: low voltage digital in 11: analog IO
	806			GPIO7output mode configuration
65	807	GPIO7Pull-up/down resistance selection	00: floating 01: 10K 10: 100K 11: 1M	
	808		GPIO7Pull-up/down selection	0: Pull-down 1: Pull-up
	809	Reserved		
	810	Reserved		
	811	GPIO7digital input LATCH configuration	00: without LATCH 01: normal LATCH 10: input data 0 LATCH (when LATCH_en is high) 11: input data 1 LATCH (when LATCH_en is high)	
	812		GPIO7input mode configuration	00: digital without Schmitt Trigger 01: digital with Schmitt Trigger 10: low voltage digital in 11: analog IO
	813			GPIO7output mode configuration
814	GPIO7Pull-up/down resistance selection	00: floating 01: 10K 10: 100K 11: 1M		
815		GPIO7Pull-up/down selection	0: Pull-down 1: Pull-up	

GreenPAK Programmable Mixed-Signal Matrix with Asynchronous State Machine and Dual Supply

Table 56: Register Map (Continued)

Address		Signal Function	Register Bit Definition
Byte	Register Bit		
66	816	GPIO7Pull-up/down selection	0: Pull-down 1: Pull-up
	817	Reserved	
	818	GPIO8 ultra-low power digital in enable (only used in SLG46881)	0: disable 1: enable
	819	GPIO8input mode configuration	00: digital without Schmitt Trigger 01: digital with Schmitt Trigger 10: low voltage digital in 11: analog IO
	820		
	821	GPIO8output mode configuration	00: Push-Pull 1x 01: Push-Pull 2x 10: 1x Open-Drain 11: 2x Open-Drain
	822		
	823	GPIO8Pull-up/down resistance selection	00: floating 01: 10K 10: 100K 11: 1M
67	824	GPIO8Pull-up/down selection	0: Pull-down 1: Pull-up
	825	GPI4 ultra-low power digital in enable (only used in SLG46881)	0: disable 1: enable
	827	GPI4digital input LATCH configuration	00: without LATCH 01: normal LATCH 10: input data 0 LATCH (when LATCH_en is high) 11: input data 1 LATCH (when LATCH_en is high)
	828		
	829	GPI4input mode configuration	00: digital without Schmitt Trigger 01: digital with Schmitt Trigger 10: low voltage digital in 11: analog IO
	830		
	831	GPI4Pull-up/down resistance selection	00: floating 01: 10K 10: 100K 11: 1M
68	832	GPI4Pull-up/down selection	0: Pull-down 1: Pull-up
	833	GPI5 ultra-low power digital in enable (only used in SLG46881)	0: disable 1: enable
	835	GPI5digital input LATCH configuration	00: without LATCH 01: normal LATCH 10: input data 0 LATCH (when LATCH_en is high) 11: input data 1 LATCH (when LATCH_en is high)
	836		
	837	GPI5input mode configuration	00: digital without Schmitt Trigger 01: digital with Schmitt Trigger 10: low voltage digital in 11: analog IO
	838		

GreenPAK Programmable Mixed-Signal Matrix with Asynchronous State Machine and Dual Supply

Table 56: Register Map (Continued)

Address		Signal Function	Register Bit Definition
Byte	Register Bit		
68	839		00: floating 01: 10K 10: 100K 11: 1M
69	840	GPI5Pull-up/down resistance selection	0: Pull-down 1: Pull-up
	841	GPI5Pull-up/down selection	0: disable 1: enable
	842	GPI6 ultra-low power digital in enable (only used in SLG46881)	00: digital without Schmitt Trigger 01: digital with Schmitt Trigger 10: low voltage digital in 11: analog IO
69	843	GPI6input mode configuration	00: floating 01: 10K 10: 100K 11: 1M
	844		0: Pull-down 1: Pull-up
	845	GPI6Pull-up/down resistance selection	0: Pull-down 1: Pull-up
	846		0: Pull-down 1: Pull-up
	847	GPI6Pull-up/down selection	0: Pull-down 1: Pull-up

GreenPAK Programmable Mixed-Signal Matrix with Asynchronous State Machine and Dual Supply
Table 56: Register Map (Continued)

Address		Signal Function	Register Bit Definition
Byte	Register Bit		
6A	848	GPI7 ultra-low power digital in enable (only used in SLG46881)	0: disable 1: enable
	849	GPI7input mode configuration	00: digital without Schmitt Trigger 01: digital with Schmitt Trigger 10: low voltage digital in 11: analog IO
	850		
	851	GPI7Pull-up/down resistance selection	00: floating 01: 10K 10: 100K 11: 1M
	852		
	853	GPI7Pull-up/down selection	0: Pull-down 1: Pull-up
	854	GPI09 ultra-low power digital in enable (only used in SLG46881)	0: disable 1: enable
	855	GPI09input mode configuration	00: digital without Schmitt Trigger 01: digital with Schmitt Trigger 10: low voltage digital in 11: analog IO
6B	856		
	857	GPI09output mode configuration	00: Push-Pull 1x 01: Push-Pull 2x 10: 1x Open-Drain 11: 2x Open-Drain
	858		
	859	GPI09Pull-up/down resistance selection	00: floating 01: 10K 10: 100K 11: 1M
	860		
	861	GPI09Pull-up/down selection	0: Pull-down 1: Pull-up
	862	GPI10 ultra-low power digital in enable (only used in SLG46881)	0: disable 1: enable
	863	GPI10input mode configuration	00: digital without Schmitt Trigger 01: digital with Schmitt Trigger 10: low voltage digital in 11: analog IO
6C	864		
	865	GPI10output mode configuration	00: Push-Pull 1x 01: Push-Pull 2x 10: 1x Open-Drain 11: 2x Open-Drain
	866		
	867	GPI10Pull-up/down resistance selection	00: floating 01: 10K 10: 100K 11: 1M.
	868		
	869	GPI10Pull-up/down selection	0: Pull-down 1: Pull-up
870	GPI11 ultra-low power digital in enable (only used in SLG46881)	0: disable 1: enable	

GreenPAK Programmable Mixed-Signal Matrix with Asynchronous State Machine and Dual Supply

Table 56: Register Map (Continued)

Address		Signal Function	Register Bit Definition						
Byte	Register Bit								
6C	871	GPIO11input mode configuration	00: digital without Schmitt Trigger 01: digital with Schmitt Trigger 10: low voltage digital in 11: analog IO						
6D	872		GPIO11output mode configuration	00: Push-Pull 1x 01: Push-Pull 2x 10: 1x Open-Drain 11: 2x Open-Drain					
	873	GPIO11Pull-up/down resistance selection		00: floating 01: 10K 10: 100K 11: 1M					
	874			GPIO11Pull-up/down selection	0: Pull-down 1: Pull-up				
	875				Reserved				
	876					Reserved			
	877						Reserved		
	878							Reserved	
	879								Reserved
6E	880		GPO5output mode configuration						
	881	GPO5Pull-up/down resistance selection	00: floating 01: 10K 10: 100K 11: 1M						
	882		GPO5Pull-up/down selection	0: Pull-down 1: Pull-up					
	883			GPO5digital output source selection	0: from matrix 1: from ASM (ASM output to GPO bit[6])				
	884				GPO5output enable	0: disable 1: enable			
	885					GPO6output mode configuration	00: Push-Pull 1x 01: Push-Pull 2x 10: 1x Open-Drain 11: 2x Open-Drain		
	886						GPO6Pull-up/down resistance selection	00: floating 01: 10K 10: 100K 11: 1M	
	887							GPO6Pull-up/down selection	0: Pull-down 1: Pull-up
6F	888								GPO6digital output source selection
	889	GPO6output enable							
	890		I ² C mode selection						
	891			XTAL enable and matrix in51 source mux select					
	892				XTAL enable and matrix in51 source mux select				
	893					XTAL enable and matrix in51 source mux select			
	894						XTAL enable and matrix in51 source mux select		
	XTAL enable and matrix in51 source mux select								
		XTAL enable and matrix in51 source mux select							

GreenPAK Programmable Mixed-Signal Matrix with Asynchronous State Machine and Dual Supply

Table 56: Register Map (Continued)

Address		Signal Function	Register Bit Definition
Byte	Register Bit		
6F	895	XTAL matrix enable signal gating	0: matrix enable signal (matrix out78) is gated and xtal is controlled by register [894] 1: matrix enable signal is effective if register [894] = 1 (matrix out78 = 0 → off, matrix out78 = 1 → on)
70	896	DLY/CNT0 Mode Selection	00:DLY 01: one shot 10: frequency det 11: cnt register [913] = 0
	897		
	898	DLY/CNT0 edge Mode Selection	00:both edge 01: falling edge 10: rising edge 11: High Level Reset (only in CNT mode)
	899		
	900	DLY/CNT0 Clock Source Select	Clock source sel[3:0] 0000: 25M; 0001: 25M/4; 0010: 2.048M 0011: 2.048M/8; 0100: 2.048M/64; 0101: 2.048M/512; 0110: 2.048K; 0111: 2.048K/8; 1000: 2.048K/64; 1001: 2.048K/512; 1010: 2.048K/4096 1011: 2.048K/32768; 1100: 2.048K/262144; 1101: CNT4_END; 1110: External; 1111: Not used
	901		
	902		
903			
71	904	FSM0 SET/RST Selection	0: Reset to 0 1: Set to data
	905	CNT0 output pol selection	0: Default Output 1: Inverted Output
	906	CNT0 initial value selection	00: bypass the initial 01: initial 0 10: initial 1 11: initial 1
	907		
	908	lut4_0 or DLY/CNT0 selection	0: LUT4_0 1: DLY/CNT0(16bits)
	909	Wake sleep power-down state selection	0: (low) 1: (high)
	910	wake sleep mode selection	0: Default Mode 1: Wake Sleep Mode (registers [897:896] = 11)
	911	Keep signal SYNC selection	0: bypass 1: after two DFFs

GreenPAK Programmable Mixed-Signal Matrix with Asynchronous State Machine and Dual Supply

Table 56: Register Map (Continued)

Address		Signal Function	Register Bit Definition
Byte	Register Bit		
72	912	UP signal SYNC selection	0: bypass 1: after two DFFs
	913	CNT0 DLY EDET FUNCTION Selection	0: normal 1: DLY function edge detection (registers [897:896] = 00)
	914	CNT0 CNT mode SYNC selection	0: bypass 1: after two DFFs
	915	CNT1 CNT mode SYNC selection	0: bypass 1: after two DFFs
72	916	DLY/CNT1 Clock Source Select	Clock source sel[3:0] 0000: 25M; 0001: 25M/4; 0010: 2.048M 0011: 2.048M/8; 0100: 2.048M/64; 0101: 2.048M/512; 0110: 2.048K; 0111: 2.048K/8; 1000: 2.048K/64; 1001: 2.048K/512; 1010: 2.048K/4096 1011: 2.048K/32768; 1100: 2.048K/262144; 1101: CNT0_END; 1110: External; 1111: Not used
	917		
	918		
	919		
73	920	CNT1 initial value selection	00: bypass the initial 01: initial 0 10: initial 1 11: initial 1
	921		
	922	CNT1 function and edge mode selection	0000: Both Edge Delay 0001: Falling Edge Delay 0010: Rising Edge Delay 0011: Both Edge One Shot 0100: Falling Edge One Shot 0101: Rising Edge One Shot 0110: Both Edge Freq Detect 0111: Falling Edge Freq Detect 1000: Rising Edge Freq Detect 1001: Both Edge Detect 1010: Falling Edge Detect 1011: Rising Edge Detect 1100: Both Edge Reset CNT 1101: Falling Edge Reset CNT 1110: Rising Edge Reset CNT 1111: High Level Reset CNT
	923		
	924		
	925		
	926		
927	LUT3_4 or CNT_1 selection	0: LUT3_4 1: DLY/CNT1(8bits)	
74	928	CNT2 CNT mode SYNC selection	0: bypass; 1: after two DFFs

GreenPAK Programmable Mixed-Signal Matrix with Asynchronous State Machine and Dual Supply

Table 56: Register Map (Continued)

Address		Signal Function	Register Bit Definition	
Byte	Register Bit			
74	929	DLY/CNT2 Clock Source Select	Clock source sel[3:0] 0000: 25M; 0001: 25M/4; 0010: 2.048M 0011: 2.048M/8; 0100: 2.048M/64; 0101: 2.048M/512; 0110: 2.048K; 0111: 2.048K/8; 1000: 2.048K/64; 1001: 2.048K/512; 1010: 2.048K/4096 1011: 2.048K/32768; 1100: 2.048K/262144; 1101: CNT1_END; 1110: External; 1111: Not used	
	930			
	931			
	932			
	933		CNT2 initial value selection	00: bypass the initial 01: initial 0 10: initial 1 11: initial 1
	934			
	935		CNT2 function and edge mode selection	0000: Both Edge Delay 0001: Falling Edge Delay 0010: Rising Edge Delay 0011: Both Edge One Shot 0100: Falling Edge One Shot 0101: Rising Edge One Shot 0110: Both Edge Freq Detect 0111: Falling Edge Freq Detect 1000: Rising Edge Freq Detect 1001: Both Edge Detect 1010: Falling Edge Detect 1011: Rising Edge Detect 1100: Both Edge Reset CNT 1101: Falling Edge Reset CNT 1110: Rising Edge Reset CNT 1111: High Level Reset CNT register [941] = 0
936				
937				
938				
939	CNT2 output pol selection	0: Default Output 1: Inverted Output		
940	LUT3_5 or CNT_2 selection	0: LUT3_5 1: DLY/CNT2(8bits)		
941	CNT2 DLY EDET FUNCTION Selection	0: normal 1: DLY function edge detection (registers [938:935]=0000/0001/0010)		
75	942	CNT3 CNT mode SYNC selection	0: bypass 1: after two DFFs	

GreenPAK Programmable Mixed-Signal Matrix with Asynchronous State Machine and Dual Supply
Table 56: Register Map (Continued)

Address		Signal Function	Register Bit Definition	
Byte	Register Bit			
75	943	DLY/CNT3 Clock Source Select	Clock source sel[3:0] 0000: 25M; 0001: 25M/4; 0010: 2.048M 0011: 2.048M/8; 0100: 2.048M/64; 0101: 2.048M/512; 0110: 2.048K; 0111: 2.048K/8; 1000: 2.048K/64; 1001: 2.048K/512; 1010: 2.048K/4096 1011: 2.048K/32768; 1100: 2.048K/262144; 1101: CNT2_END; 1110: External; 1111: Not used	
	944			
	945			
	946			
	947		CNT3 initial value selection	00: bypass the initial 01: initial 0 10: initial 1 11: initial 1
	948			
	949		CNT3 function and edge mode selection	0000: Both Edge Delay 0001: Falling Edge Delay 0010: Rising Edge Delay 0011: Both Edge One Shot 0100: Falling Edge One Shot 0101: Rising Edge One Shot 0110: Both Edge Freq Detect 0111: Falling Edge Freq Detect 1000: Rising Edge Freq Detect 1001: Both Edge Detect 1010: Falling Edge Detect 1011: Rising Edge Detect 1100: Both Edge Reset CNT 1101: Falling Edge Reset CNT 1110: Rising Edge Reset CNT 1111: High Level Reset CNT
	950			
	951			
	952			
77	953	CNT3 output pol selection	0: Default Output 1: Inverted Output	
	954	LUT3_6 or CNT_3 selection	0: LUT3_6 1: DLY/CNT3(8bits)	
	955	CNT4 CNT mode SYNC selection	0: bypass 1: after two DFFs	

GreenPAK Programmable Mixed-Signal Matrix with Asynchronous State Machine and Dual Supply
Table 56: Register Map (Continued)

Address		Signal Function	Register Bit Definition
Byte	Register Bit		
77	956	DLY/CNT4 Clock Source Select	Clock source sel[3:0] 0000: 25M; 0001: 25M/4; 0010: 2.048M 0011: 2.048M/8; 0100: 2.048M/64; 0101: 2.048M/512; 0110: 2.048K; 0111: 2.048K/8; 1000: 2.048K/64; 1001: 2.048K/512; 1010: 2.048K/4096 1011: 2.048K/32768; 1100: 2.048K/262144; 1101: CNT3_END; 1110: External; 1111: Not used
	957		
	958		
	959		
78	960	CNT4 initial value selection	00: bypass the initial 01: initial 0 10: initial 1 11: initial 1
	961		
	962	CNT4 function and edge mode selection	0000: Both Edge Delay 0001: Falling Edge Delay 0010: Rising Edge Delay 0011: Both Edge One Shot 0100: Falling Edge One Shot 0101: Rising Edge One Shot 0110: Both Edge Freq Detect 0111: Falling Edge Freq Detect 1000: Rising Edge Freq Detect 1001: Both Edge Detect 1010: Falling Edge Detect 1011: Rising Edge Detect 1100: Both Edge Reset CNT 1101: Falling Edge Reset CNT 1110: Rising Edge Reset CNT 1111: High Level Reset CNT
	963		
	964		
	965		
	966		
967	LUT3_7 or CNT_4 selection	0: LUT3_7 1: DLY/CNT4(8bits)	
79	968	REG_TEST_EN	
79	969	Reserved	
	970		
	971		
	972		
	973	Reserved	
	974	Reserved	
	975	Reserved	

GreenPAK Programmable Mixed-Signal Matrix with Asynchronous State Machine and Dual Supply

Table 56: Register Map (Continued)

Address		Signal Function	Register Bit Definition
Byte	Register Bit		
7A	976	ASM State 0 Output Memory for 8 GPOs	Memory for GPO 0
	977		Memory for GPO 1
	978		Memory for GPO 2
	979		Memory for GPO 3
	980		Memory for GPO 4
	981		Memory for GPO 5
	982		Memory for GPO 6
	983		Memory for GPO 7
7B	984	ASM State 1 Output Memory for 8 GPOs	Memory for GPO 0
	985		Memory for GPO 1
	986		Memory for GPO 2
	987		Memory for GPO 3
	988		Memory for GPO 4
	989		Memory for GPO 5
	990		Memory for GPO 6
	991		Memory for GPO 7
7C	992	ASM State 2 Output Memory for 8 GPOs	Memory for GPO 0
	993		Memory for GPO 1
	994		Memory for GPO 2
	995		Memory for GPO 3
	996		Memory for GPO 4
	997		Memory for GPO 5
	998		Memory for GPO 6
	999		Memory for GPO 7
7D	1000	ASM State 3 Output Memory for 8 GPOs	Memory for GPO 0
	1001		Memory for GPO 1
	1002		Memory for GPO 2
	1003		Memory for GPO 3
	1004		Memory for GPO 4
	1005		Memory for GPO 5
	1006		Memory for GPO 6
	1007		Memory for GPO 7
7E	1008	ASM State 4 Output Memory for 8 GPOs	Memory for GPO 0
	1009		Memory for GPO 1
	1010		Memory for GPO 2
	1011		Memory for GPO 3
	1012		Memory for GPO 4
	1013		Memory for GPO 5
	1014		Memory for GPO 6
	1015		Memory for GPO 7

GreenPAK Programmable Mixed-Signal Matrix with Asynchronous State Machine and Dual Supply

Table 56: Register Map (Continued)

Address		Signal Function	Register Bit Definition
Byte	Register Bit		
7F	1016	ASM State 5 Output Memory for 8 GPOs	Memory for GPO 0
	1017		Memory for GPO 1
	1018		Memory for GPO 2
	1019		Memory for GPO 3
	1020		Memory for GPO 4
	1021		Memory for GPO 5
	1022		Memory for GPO 6
	1023		Memory for GPO 7
80	1024	ASM State 6 Output Memory for 8 GPOs	Memory for GPO 0
	1025		Memory for GPO 1
	1026		Memory for GPO 2
	1027		Memory for GPO 3
	1028		Memory for GPO 4
	1029		Memory for GPO 5
	1030		Memory for GPO 6
	1031		Memory for GPO 7
81	1032	ASM State 7 Output Memory for 8 GPOs	Memory for GPO 0
	1033		Memory for GPO 1
	1034		Memory for GPO 2
	1035		Memory for GPO 3
	1036		Memory for GPO 4
	1037		Memory for GPO 5
	1038		Memory for GPO 6
	1039		Memory for GPO 7
82	1040	ASM State 8 Output Memory for 8 GPOs	Memory for GPO 0
	1041		Memory for GPO 1
	1042		Memory for GPO 2
	1043		Memory for GPO 3
	1044		Memory for GPO 4
	1045		Memory for GPO 5
	1046		Memory for GPO 6
	1047		Memory for GPO 7
83	1048	ASM State 9 Output Memory for 8 GPOs	Memory for GPO 0
	1049		Memory for GPO 1
	1050		Memory for GPO 2
	1051		Memory for GPO 3
	1052		Memory for GPO 4
	1053		Memory for GPO 5
	1054		Memory for GPO 6
	1055		Memory for GPO 7

GreenPAK Programmable Mixed-Signal Matrix with Asynchronous State Machine and Dual Supply

Table 56: Register Map (Continued)

Address		Signal Function	Register Bit Definition
Byte	Register Bit		
84	1056	ASM State 10 Output Memory for 8 GPOs	Memory for GPO 0
	1057		Memory for GPO 1
	1058		Memory for GPO 2
	1059		Memory for GPO 3
	1060		Memory for GPO 4
	1061		Memory for GPO 5
	1062		Memory for GPO 6
	1063		Memory for GPO 7
85	1064	ASM State 11 Output Memory for 8 GPOs	Memory for GPO 0
	1065		Memory for GPO 1
	1066		Memory for GPO 2
	1067		Memory for GPO 3
	1068		Memory for GPO 4
	1069		Memory for GPO 5
	1070		Memory for GPO 6
	1071		Memory for GPO 7
86	1072	ASM State 0 Output Memory for Matrix Input	Memory for Matrix input 0
	1073		Memory for Matrix input 1
	1074		Memory for Matrix input 2
	1075		Memory for Matrix input 3
	1076	ASM State 1 Output Memory for Matrix Input	Memory for Matrix input 0
	1077		Memory for Matrix input 1
	1078		Memory for Matrix input 2
	1079		Memory for Matrix input 3
87	1080	ASM State 2 Output Memory for Matrix Input	Memory for Matrix input 0
	1081		Memory for Matrix input 1
	1082		Memory for Matrix input 2
	1083		Memory for Matrix input 3
	1084	ASM State 3 Output Memory for Matrix Input	Memory for Matrix input 0
	1085		Memory for Matrix input 1
	1086		Memory for Matrix input 2
	1087		Memory for Matrix input 3
88	1088	ASM State 4 Output Memory for Matrix Input	Memory for Matrix input 0
	1089		Memory for Matrix input 1
	1090		Memory for Matrix input 2
	1091		Memory for Matrix input 3
	1092	ASM State 5 Output Memory for Matrix Input	Memory for Matrix input 0
	1093		Memory for Matrix input 1
	1094		Memory for Matrix input 2
	1095		Memory for Matrix input 3

GreenPAK Programmable Mixed-Signal Matrix with Asynchronous State Machine and Dual Supply

Table 56: Register Map (Continued)

Address		Signal Function	Register Bit Definition
Byte	Register Bit		
89	1096	ASM State 6 Output Memory for Matrix Input	Memory for Matrix input 0
	1097		Memory for Matrix input 1
	1098		Memory for Matrix input 2
	1099		Memory for Matrix input 3
	1100	ASM State 7 Output Memory for Matrix Input	Memory for Matrix input 0
	1101		Memory for Matrix input 1
	1102		Memory for Matrix input 2
	1103		Memory for Matrix input 3
8A	1104	ASM State 8 Output Memory for Matrix Input	Memory for Matrix input 0
	1105		Memory for Matrix input 1
	1106		Memory for Matrix input 2
	1107		Memory for Matrix input 3
	1108	ASM State 9 Output Memory for Matrix Input	Memory for Matrix input 0
	1109		Memory for Matrix input 1
	1110		Memory for Matrix input 2
	1111		Memory for Matrix input 3
8B	1112	ASM State 10 Output Memory for Matrix Input	Memory for Matrix input 0
	1113		Memory for Matrix input 1
	1114		Memory for Matrix input 2
	1115		Memory for Matrix input 3
	1116	ASM State 11 Output Memory for Matrix Input	Memory for Matrix input 0
	1117		Memory for Matrix input 1
	1118		Memory for Matrix input 2
	1119		Memory for Matrix input 3
8C	1120	ASM Initial State Selection	0000 → 1011: State 0 → State 11
	1121		
	1122		
	1123		
	1124	Reserved registers for ASM	
	1125		
	1126		
	1127		

GreenPAK Programmable Mixed-Signal Matrix with Asynchronous State Machine and Dual Supply
Table 56: Register Map (Continued)

Address		Signal Function	Register Bit Definition
Byte	Register Bit		
8D	1128	6Bit MATRIX_IN_Setting0	OUT0_Setting0: REG_MATRIX_IN_SEL[5:0]
	1129		
	1130		
	1131		
	1132		
	1133		
	1134		
8E	1135	6Bit MATRIX_IN_Setting1	OUT0_Setting0: REG_MATRIX_IN_SEL[11:6]
	1136		
	1137		
	1138		
	1139		
	1140		
	1141		
8F	1142	6Bit MATRIX_IN_Setting2	OUT0_Setting0: REG_MATRIX_IN_SEL[17:12]
	1143		
	1144		
	1145		
	1146		
	1147		
	1148		
8F	1149	6Bit MATRIX_IN_Setting3	OUT0_Setting0: REG_MATRIX_IN_SEL[23:18]
	1150		
	1151		
	1151		

GreenPAK Programmable Mixed-Signal Matrix with Asynchronous State Machine and Dual Supply
Table 56: Register Map (Continued)

Address		Signal Function	Register Bit Definition
Byte	Register Bit		
90	1152	6Bit MATRIX_IN_Setting0	OUT1_Setting0: REG_MATRIX_IN_SEL[5:0]
	1153		
	1154		
	1155		
	1156		
	1157		
	1158		
91	1159	6Bit MATRIX_IN_Setting1	OUT1_Setting0: REG_MATRIX_IN_SEL[11:6]
	1160		
	1161		
	1162		
	1163		
	1164		
	1165		
92	1166	6Bit MATRIX_IN_Setting2	OUT1_Setting0: REG_MATRIX_IN_SEL[17:12]
	1167		
	1168		
	1169		
	1170		
	1171		
	1172		
92	1173	6Bit MATRIX_IN_Setting3	OUT1_Setting0: REG_MATRIX_IN_SEL[23:18]
	1174		
	1175		

GreenPAK Programmable Mixed-Signal Matrix with Asynchronous State Machine and Dual Supply

Table 56: Register Map (Continued)

Address		Signal Function	Register Bit Definition
Byte	Register Bit		
93	1176	6Bit MATRIX_IN_Setting0	OUT2_Setting0: REG_MATRIX_IN_SEL[5:0]
	1177		
	1178		
	1179		
	1180		
	1181		
	1182		
94	1183	6Bit MATRIX_IN_Setting1	OUT2_Setting0: REG_MATRIX_IN_SEL[11:6]
	1184		
	1185		
	1186		
	1187		
	1188		
	1189		
95	1190	6Bit MATRIX_IN_Setting2	OUT2_Setting0: REG_MATRIX_IN_SEL[17:12]
	1191		
	1192		
	1193		
95	1194	6Bit MATRIX_IN_Setting3	OUT2_Setting0: REG_MATRIX_IN_SEL[23:18]
	1195		
	1196		
	1197		
	1198		
	1199		
96	1200	State0_6BitMatrix_OUT0 4 Settings selection	00: Settings 0 01: Settings 1 10: Settings 2 11: Settings 3
	1201		
	1202	State0_6BitMatrix_OUT1 4 Settings selection	00: Settings 0 01: Settings 1 10: Settings 2 11: Settings 3
	1203		
	1204	State0_6BitMatrix_OUT2 4 Settings selection	00: Settings 0 01: Settings 1 10: Settings 2 11: Settings 3
	1205		
	1206	State1_6BitMatrix_OUT0 4 Settings selection	00: Settings 0 01: Settings 1 10: Settings 2 11: Settings 3
	1207		

GreenPAK Programmable Mixed-Signal Matrix with Asynchronous State Machine and Dual Supply
Table 56: Register Map (Continued)

Address		Signal Function	Register Bit Definition
Byte	Register Bit		
97	1208	State1_6BitMatrix_OUT1 4 Settings selection	00: Settings 0
	1209		01: Settings 1
	1210	State1_6BitMatrix_OUT2 4 Settings selection	10: Settings 2
	1211		11: Settings 3
	1212	State2_6BitMatrix_OUT0 4 Settings selection	00: Settings 0
	1213		01: Settings 1
	1214	State2_6BitMatrix_OUT1 4 Settings selection	10: Settings 2
	1215		11: Settings 3
98	1216	State2_6BitMatrix_OUT2 4 Settings selection	00: Settings 0
	1217		01: Settings 1
	1218	State3_6BitMatrix_OUT0 4 Settings selection	10: Settings 2
	1219		11: Settings 3
	1220	State3_6BitMatrix_OUT1 4 Settings selection	00: Settings 0
	1221		01: Settings 1
98	1222	State3_6BitMatrix_OUT2 4 Settings selection	10: Settings 2
	1223		11: Settings 3
99	1224	State4_6BitMatrix_OUT0 4 Settings selection	00: Settings 0
	1225		01: Settings 1
	1226	State4_6BitMatrix_OUT1 4 Settings selection	10: Settings 2
	1227		11: Settings 3
	1228	State4_6BitMatrix_OUT2 4 Settings selection	00: Settings 0
	1229		01: Settings 1
	1230	State5_6BitMatrix_OUT0 4 Settings selection	10: Settings 2
	1231		11: Settings 3

GreenPAK Programmable Mixed-Signal Matrix with Asynchronous State Machine and Dual Supply

Table 56: Register Map (Continued)

Address		Signal Function	Register Bit Definition
Byte	Register Bit		
9A	1232	State5_6BitMatrix_OUT1 4 Settings selection	00: Settings 0 01: Settings 1 10: Settings 2 11: Settings 3
	1233		
	1234	State5_6BitMatrix_OUT2 4 Settings selection	00: Settings 0 01: Settings 1 10: Settings 2 11: Settings 3
	1235		
	1236	State6_6BitMatrix_OUT0 4 Settings selection	00: Settings 0 01: Settings 1 10: Settings 2 11: Settings 3
	1237		
	1238	State6_6BitMatrix_OUT1 4 Settings selection	00: Settings 0 01: Settings 1 10: Settings 2 11: Settings 3
	1239		
9B	1240	State6_6BitMatrix_OUT2 4 Settings selection	00: Settings 0 01: Settings 1 10: Settings 2 11: Settings 3
	1241		
	1242	State7_6BitMatrix_OUT0 4 Settings selection	00: Settings 0 01: Settings 1 10: Settings 2 11: Settings 3
	1243		
	1244	State7_6BitMatrix_OUT1 4 Settings selection	00: Settings 0 01: Settings 1 10: Settings 2 11: Settings 3
	1245		
	1246	State7_6BitMatrix_OUT2 4 Settings selection	00: Settings 0 01: Settings 1 10: Settings 2 11: Settings 3
	1247		
9C	1248	State8_6BitMatrix_OUT0 4 Settings selection	00: Settings 0 01: Settings 1 10: Settings 2 11: Settings 3
	1249		
	1250	State8_6BitMatrix_OUT1 4 Settings selection	00: Settings 0 01: Settings 1 10: Settings 2 11: Settings 3
	1251		
	1252	State8_6BitMatrix_OUT2 4 Settings selection	00: Settings 0 01: Settings 1 10: Settings 2 11: Settings 3
	1253		
	1254	State9_6BitMatrix_OUT0 4 Settings selection	00: Settings 0 01: Settings 1 10: Settings 2 11: Settings 3
	1255		

GreenPAK Programmable Mixed-Signal Matrix with Asynchronous State Machine and Dual Supply
Table 56: Register Map (Continued)

Address		Signal Function	Register Bit Definition
Byte	Register Bit		
9D	1256	State9_6BitMatrix_OUT1 4 Settings selection	00: Settings 0
	1257		01: Settings 1
	1258	State9_6BitMatrix_OUT2 4 Settings selection	10: Settings 2
	1259		11: Settings 3
	1260	State10_6BitMatrix_OUT0 4 Settings selection	00: Settings 0
	1261		01: Settings 1
	1262	State10_6BitMatrix_OUT1 4 Settings selection	10: Settings 2
	1263		11: Settings 3
9E	1264	State10_6BitMatrix_OUT2 4 Settings selection	00: Settings 0
	1265		01: Settings 1
	1266	State11_6BitMatrix_OUT0 4 Settings selection	10: Settings 2
	1267		11: Settings 3
	1268	State11_6BitMatrix_OUT1 4 Settings selection	00: Settings 0
	1269		01: Settings 1
	1270	State11_6BitMatrix_OUT2 4 Settings selection	10: Settings 2
	1271		11: Settings 3

GreenPAK Programmable Mixed-Signal Matrix with Asynchronous State Machine and Dual Supply

Table 56: Register Map (Continued)

Address		Signal Function	Register Bit Definition
Byte	Register Bit		
9F	1272	ASM Input Matrix (Signal Source for State 0 →State 0 Transition)	000: VSS; 001: 6Bit_Matrix_OUT0; 010: 6Bit_Matrix_OUT1; 011: 6Bit_Matrix_OUT2; 100: DM0_0; 101: DM0_1; 110: DM1_0; 111: DM1_1
	1273		
	1274		
	1275	ASM Input Matrix (Signal Source for State 0 →State 1 Transition)	000: VSS; 001: 6Bit_Matrix_OUT0; 010: 6Bit_Matrix_OUT1; 011: 6Bit_Matrix_OUT2; 100: DM0_0; 101: DM0_1; 110: DM1_0; 111: DM1_1
	1276		
	1277		
A0	1278	ASM Input Matrix (Signal Source for State 0 →State 2 Transition)	000: VSS; 001: 6Bit_Matrix_OUT0; 010: 6Bit_Matrix_OUT1; 011: 6Bit_Matrix_OUT2; 100: DM0_0; 101: DM0_1; 110: DM1_0; 111: DM1_1
	1279		
	1280		
	1281	ASM Input Matrix (Signal Source for State 0 →State 3 Transition)	000: VSS; 001: 6Bit_Matrix_OUT0; 010: 6Bit_Matrix_OUT1; 011: 6Bit_Matrix_OUT2; 100: DM0_0; 101: DM0_1; 110: DM1_0; 111: DM1_1
	1282		
	1283		
A1	1284	ASM Input Matrix (Signal Source for State 0 →State 4 Transition)	000: VSS; 001: 6Bit_Matrix_OUT0; 010: 6Bit_Matrix_OUT1; 011: 6Bit_Matrix_OUT2; 100: DM0_0; 101: DM0_1; 110: DM1_0; 111: DM1_1
	1285		
	1286		
	1287		
A1	1288	ASM Input Matrix (Signal Source for State 0 →State 5 Transition)	000: VSS; 001: 6Bit_Matrix_OUT0; 010: 6Bit_Matrix_OUT1; 011: 6Bit_Matrix_OUT2; 100: DM0_0; 101: DM0_1; 110: DM1_0; 111: DM1_1
	1289		
	1290	ASM Input Matrix (Signal Source for State 0 →State 6 Transition)	000: VSS; 001: 6Bit_Matrix_OUT0; 010: 6Bit_Matrix_OUT1; 011: 6Bit_Matrix_OUT2; 100: DM0_0; 101: DM0_1; 110: DM1_0; 111: DM1_1
	1291		
	1292		

GreenPAK Programmable Mixed-Signal Matrix with Asynchronous
 State Machine and Dual Supply

Table 56: Register Map (Continued)

Address		Signal Function	Register Bit Definition
Byte	Register Bit		
A1	1293	ASM Input Matrix (Signal Source for State 0 →State 7 Transition)	000: VSS; 001: 6Bit_Matrix_OUT0; 010: 6Bit_Matrix_OUT1; 011: 6Bit_Matrix_OUT2; 100: DM0_0; 101: DM0_1; 110: DM1_0; 111: DM1_1
	1294		
	1295		

GreenPAK Programmable Mixed-Signal Matrix with Asynchronous State Machine and Dual Supply

Table 56: Register Map (Continued)

Address		Signal Function	Register Bit Definition	
Byte	Register Bit			
A2	1296	ASM Input Matrix (Signal Source for State 0 →State 8 Transition)	000: VSS; 001: 6Bit_Matrix_OUT0; 010: 6Bit_Matrix_OUT1; 011: 6Bit_Matrix_OUT2; 100: DM0_0; 101: DM0_1; 110: DM1_0; 111: DM1_1	
	1297			
	1298			
	1299	ASM Input Matrix (Signal Source for State 0 →State 9 Transition)	000: VSS; 001: 6Bit_Matrix_OUT0; 010: 6Bit_Matrix_OUT1; 011: 6Bit_Matrix_OUT2; 100: DM0_0; 101: DM0_1; 110: DM1_0; 111: DM1_1	
	1300			
	1301			
	1302	ASM Input Matrix (Signal Source for State 0 →State 10 Transition)	000: VSS; 001: 6Bit_Matrix_OUT0; 010: 6Bit_Matrix_OUT1; 011: 6Bit_Matrix_OUT2; 100: DM0_0; 101: DM0_1; 110: DM1_0; 111: DM1_1	
	1303			
	1304			
A3		ASM Input Matrix (Signal Source for State 0 →State 11 Transition)	000: VSS; 001: 6Bit_Matrix_OUT0; 010: 6Bit_Matrix_OUT1; 011: 6Bit_Matrix_OUT2; 100: DM0_0; 101: DM0_1; 110: DM1_0; 111: DM1_1	
			1305	
			1306	
		1307	ASM Input Matrix (Signal Source for State 1 →State 10 Transition), bit [2] Note: This bit, along with registers [1343:1342], select the signal source for State 1 to State 10 Transition	000: VSS; 001: 6Bit_Matrix_OUT0; 010: 6Bit_Matrix_OUT1; 011: 6Bit_Matrix_OUT2; 100: DM0_0; 101: DM0_1; 110: DM1_0; 111: DM1_1
		1308		
		1309		
	1310	ASM Input Matrix (Signal Source for State 1 →State 11 Transition)	000: VSS; 001: 6Bit_Matrix_OUT0; 010: 6Bit_Matrix_OUT1; 011: 6Bit_Matrix_OUT2; 100: DM0_0; 101: DM0_1; 110: DM1_0; 111: DM1_1	
	1311			

GreenPAK Programmable Mixed-Signal Matrix with Asynchronous State Machine and Dual Supply

Table 56: Register Map (Continued)

Address		Signal Function	Register Bit Definition
Byte	Register Bit		
A4	1312	ASM Input Matrix (Signal Source for State 1 →State 0 Transition)	000: VSS;
	1313		001: 6Bit_Matrix_OUT0;
	1314		010: 6Bit_Matrix_OUT1;
	1315	ASM Input Matrix (Signal Source for State 1 →State 1 Transition)	011: 6Bit_Matrix_OUT2;
	1316		100: DM0_0;
	1317		101: DM0_1;
	1318	ASM Input Matrix (Signal Source for State 1 →State 2 Transition)	110: DM1_0;
	1319		111: DM1_1
1320	000: VSS;		
A5	1321	ASM Input Matrix (Signal Source for State 1 →State 3 Transition)	001: 6Bit_Matrix_OUT0;
	1322		010: 6Bit_Matrix_OUT1;
	1323		011: 6Bit_Matrix_OUT2;
	1324	ASM Input Matrix (Signal Source for State 1 →State 4 Transition)	100: DM0_0;
	1325		101: DM0_1;
	1326		110: DM1_0;
	1327	ASM Input Matrix (Signal Source for State 1 →State 5 Transition)	111: DM1_1
1328	000: VSS;		
1329	001: 6Bit_Matrix_OUT0;		
A6	1330	ASM Input Matrix (Signal Source for State 1 →State 6 Transition)	010: 6Bit_Matrix_OUT1;
	1331		011: 6Bit_Matrix_OUT2;
	1332		100: DM0_0;
			101: DM0_1;
			110: DM1_0;
			111: DM1_1

GreenPAK Programmable Mixed-Signal Matrix with Asynchronous State Machine and Dual Supply

Table 56: Register Map (Continued)

Address		Signal Function	Register Bit Definition
Byte	Register Bit		
A6	1333	ASM Input Matrix (Signal Source for State 1 →State 7 Transition)	000: VSS; 001: 6Bit_Matrix_OUT0; 010: 6Bit_Matrix_OUT1; 011: 6Bit_Matrix_OUT2; 100: DM0_0; 101: DM0_1; 110: DM1_0; 111: DM1_1
	1334		
	1335		
A7	1336	ASM Input Matrix (Signal Source for State 1 →State 8 Transition)	000: VSS; 001: 6Bit_Matrix_OUT0; 010: 6Bit_Matrix_OUT1; 011: 6Bit_Matrix_OUT2; 100: DM0_0; 101: DM0_1; 110: DM1_0; 111: DM1_1
	1337		
	1338		
	1339	ASM Input Matrix (Signal Source for State 1 →State 9 Transition)	000: VSS; 001: 6Bit_Matrix_OUT0; 010: 6Bit_Matrix_OUT1; 011: 6Bit_Matrix_OUT2; 100: DM0_0; 101: DM0_1; 110: DM1_0; 111: DM1_1
	1340		
	1341		
	1342	ASM Input Matrix (Signal Source for State 1 →State 10 Transition), bits [1:0] Note: These bits, along with register [1308], select the signal source for State 1 to State 10 Transition	000: VSS; 001: 6Bit_Matrix_OUT0; 010: 6Bit_Matrix_OUT1; 011: 6Bit_Matrix_OUT2; 100: DM0_0; 101: DM0_1; 110: DM1_0; 111: DM1_1
1343			

GreenPAK Programmable Mixed-Signal Matrix with Asynchronous State Machine and Dual Supply
Table 56: Register Map (Continued)

Address		Signal Function	Register Bit Definition
Byte	Register Bit		
A8	1344	ASM Input Matrix (Signal Source for State 2 →State 0 Transition)	000: VSS; 001: 6Bit_Matrix_OUT0; 010: 6Bit_Matrix_OUT1; 011: 6Bit_Matrix_OUT2; 100: DM0_0; 101: DM0_1; 110: DM1_0; 111: DM1_1
	1345		
	1346		
	1347	ASM Input Matrix (Signal Source for State 2 →State 1 Transition)	000: VSS; 001: 6Bit_Matrix_OUT0; 010: 6Bit_Matrix_OUT1; 011: 6Bit_Matrix_OUT2; 100: DM0_0; 101: DM0_1; 110: DM1_0; 111: DM1_1
	1348		
	1349		
		1350	ASM Input Matrix (Signal Source for State 2 →State 2 Transition)
	1351		
A9	1352		

GreenPAK Programmable Mixed-Signal Matrix with Asynchronous State Machine and Dual Supply

Table 56: Register Map (Continued)

Address		Signal Function	Register Bit Definition
Byte	Register Bit		
A9	1353	ASM Input Matrix (Signal Source for State 2 →State 3 Transition)	000: VSS;
	1354		001: 6Bit_Matrix_OUT0;
	1355		010: 6Bit_Matrix_OUT1;
	1356	ASM Input Matrix (Signal Source for State 2 →State 4 Transition)	011: 6Bit_Matrix_OUT2;
	1357		100: DM0_0;
	1358		101: DM0_1;
AA	1359	ASM Input Matrix (Signal Source for State 2 →State 5 Transition)	110: DM1_0;
	1360		111: DM1_1
	1361	ASM Input Matrix (Signal Source for State 2 →State 6 Transition)	000: VSS;
	1362		001: 6Bit_Matrix_OUT0;
	1363		010: 6Bit_Matrix_OUT1;
	1364	ASM Input Matrix (Signal Source for State 2 →State 7 Transition)	011: 6Bit_Matrix_OUT2;
	1365		100: DM0_0;
	1366		101: DM0_1;
1367		110: DM1_0;	
		111: DM1_1	

GreenPAK Programmable Mixed-Signal Matrix with Asynchronous State Machine and Dual Supply

Table 56: Register Map (Continued)

Address		Signal Function	Register Bit Definition
Byte	Register Bit		
AB	1368	ASM Input Matrix (Signal Source for State 2 →State 8 Transition)	000: VSS; 001: 6Bit_Matrix_OUT0; 010: 6Bit_Matrix_OUT1; 011: 6Bit_Matrix_OUT2; 100: DM0_0; 101: DM0_1; 110: DM1_0; 111: DM1_1
	1369		
	1370		
	1371	ASM Input Matrix (Signal Source for State 2 →State 9 Transition)	000: VSS; 001: 6Bit_Matrix_OUT0; 010: 6Bit_Matrix_OUT1; 011: 6Bit_Matrix_OUT2; 100: DM0_0; 101: DM0_1; 110: DM1_0; 111: DM1_1
	1372		
	1373		
AB	1374	ASM Input Matrix (Signal Source for State 2 →State 10 Transition)	000: VSS; 001: 6Bit_Matrix_OUT0; 010: 6Bit_Matrix_OUT1; 011: 6Bit_Matrix_OUT2; 100: DM0_0; 101: DM0_1; 110: DM1_0; 111: DM1_1
	1375		
AC	1376	ASM Input Matrix (Signal Source for State 2 →State 11 Transition)	000: VSS; 001: 6Bit_Matrix_OUT0; 010: 6Bit_Matrix_OUT1; 011: 6Bit_Matrix_OUT2; 100: DM0_0; 101: DM0_1; 110: DM1_0; 111: DM1_1
	1377		
	1378		
	1379	ASM Input Matrix (Signal Source for State 3 →State 10 Transition), bit [2] Note: This bit, along with registers [1415:1414], select the signal source for State 3 to State 10 Transition	000: VSS; 001: 6Bit_Matrix_OUT0; 010: 6Bit_Matrix_OUT1; 011: 6Bit_Matrix_OUT2; 100: DM0_0; 101: DM0_1; 110: DM1_0; 111: DM1_1
	1380		
	1381		
	1382	ASM Input Matrix (Signal Source for State 3 →State 11 Transition)	000: VSS; 001: 6Bit_Matrix_OUT0; 010: 6Bit_Matrix_OUT1; 011: 6Bit_Matrix_OUT2; 100: DM0_0; 101: DM0_1; 110: DM1_0; 111: DM1_1
1383			

GreenPAK Programmable Mixed-Signal Matrix with Asynchronous State Machine and Dual Supply
Table 56: Register Map (Continued)

Address		Signal Function	Register Bit Definition
Byte	Register Bit		
AD	1384	ASM Input Matrix (Signal Source for State 3 →State 0 Transition)	000: VSS; 001: 6Bit_Matrix_OUT0; 010: 6Bit_Matrix_OUT1; 011: 6Bit_Matrix_OUT2; 100: DM0_0; 101: DM0_1; 110: DM1_0; 111: DM1_1
	1385		
	1386		
	1387	ASM Input Matrix (Signal Source for State 3 →State 1 Transition)	000: VSS; 001: 6Bit_Matrix_OUT0; 010: 6Bit_Matrix_OUT1; 011: 6Bit_Matrix_OUT2; 100: DM0_0; 101: DM0_1; 110: DM1_0; 111: DM1_1
	1388		
	1389		
AE	1390	ASM Input Matrix (Signal Source for State 3 →State 2 Transition)	000: VSS; 001: 6Bit_Matrix_OUT0; 010: 6Bit_Matrix_OUT1; 011: 6Bit_Matrix_OUT2; 100: DM0_0; 101: DM0_1; 110: DM1_0; 111: DM1_1
	1391		
AE	1392	ASM Input Matrix (Signal Source for State 3 →State 2 Transition)	000: VSS; 001: 6Bit_Matrix_OUT0; 010: 6Bit_Matrix_OUT1; 011: 6Bit_Matrix_OUT2; 100: DM0_0; 101: DM0_1; 110: DM1_0; 111: DM1_1

GreenPAK Programmable Mixed-Signal Matrix with Asynchronous State Machine and Dual Supply
Table 56: Register Map (Continued)

Address		Signal Function	Register Bit Definition
Byte	Register Bit		
AE	1393	ASM Input Matrix (Signal Source for State 3 →State 3 Transition)	000: VSS; 001: 6Bit_Matrix_OUT0; 010: 6Bit_Matrix_OUT1; 011: 6Bit_Matrix_OUT2; 100: DM0_0; 101: DM0_1; 110: DM1_0; 111: DM1_1
	1394		
	1395		
	1396	ASM Input Matrix (Signal Source for State 3 →State 4 Transition)	000: VSS; 001: 6Bit_Matrix_OUT0; 010: 6Bit_Matrix_OUT1; 011: 6Bit_Matrix_OUT2; 100: DM0_0; 101: DM0_1; 110: DM1_0; 111: DM1_1
	1397		
	1398		
AF	1399	ASM Input Matrix (Signal Source for State 3 →State 5 Transition)	000: VSS; 001: 6Bit_Matrix_OUT0; 010: 6Bit_Matrix_OUT1; 011: 6Bit_Matrix_OUT2; 100: DM0_0; 101: DM0_1; 110: DM1_0; 111: DM1_1
	1400		
	1401		000: VSS; 001: 6Bit_Matrix_OUT0; 010: 6Bit_Matrix_OUT1; 011: 6Bit_Matrix_OUT2; 100: DM0_0; 101: DM0_1; 110: DM1_0; 111: DM1_1
	1402	ASM Input Matrix (Signal Source for State 3 →State 6 Transition)	000: VSS; 001: 6Bit_Matrix_OUT0; 010: 6Bit_Matrix_OUT1; 011: 6Bit_Matrix_OUT2; 100: DM0_0; 101: DM0_1; 110: DM1_0; 111: DM1_1
	1403		
	1404		
	1405	ASM Input Matrix (Signal Source for State 3 →State 7 Transition)	000: VSS; 001: 6Bit_Matrix_OUT0; 010: 6Bit_Matrix_OUT1; 011: 6Bit_Matrix_OUT2; 100: DM0_0; 101: DM0_1; 110: DM1_0; 111: DM1_1
	1406		
1407			

GreenPAK Programmable Mixed-Signal Matrix with Asynchronous State Machine and Dual Supply
Table 56: Register Map (Continued)

Address		Signal Function	Register Bit Definition
Byte	Register Bit		
BO	1408	ASM Input Matrix (Signal Source for State 3 →State 8 Transition)	000: VSS; 001: 6Bit_Matrix_OUT0; 010: 6Bit_Matrix_OUT1; 011: 6Bit_Matrix_OUT2; 100: DM0_0; 101: DM0_1; 110: DM1_0; 111: DM1_1
	1409		
	1410		
	1411	ASM Input Matrix (Signal Source for State 3 →State 9 Transition)	000: VSS; 001: 6Bit_Matrix_OUT0; 010: 6Bit_Matrix_OUT1; 011: 6Bit_Matrix_OUT2; 100: DM0_0; 101: DM0_1; 110: DM1_0; 111: DM1_1
	1412		
	1413		
BO	1414	ASM Input Matrix (Signal Source for State 3 →State 10 Transition), bits [1:0] Note: These bits, along with registers [1380], select the signal source for State 3 to State 10 Transition	000: VSS; 001: 6Bit_Matrix_OUT0; 010: 6Bit_Matrix_OUT1; 011: 6Bit_Matrix_OUT2; 100: DM0_0; 101: DM0_1; 110: DM1_0; 111: DM1_1
	1415		

GreenPAK Programmable Mixed-Signal Matrix with Asynchronous State Machine and Dual Supply

Table 56: Register Map (Continued)

Address		Signal Function	Register Bit Definition	
Byte	Register Bit			
B1	1416	ASM Input Matrix (Signal Source for State 4 →State 0 Transition)	000: VSS; 001: 6Bit_Matrix_OUT0; 010: 6Bit_Matrix_OUT1; 011: 6Bit_Matrix_OUT2; 100: DM0_0; 101: DM0_1; 110: DM1_0; 111: DM1_1	
	1417			
	1418			
	1419	ASM Input Matrix (Signal Source for State 4 →State 1 Transition)	000: VSS; 001: 6Bit_Matrix_OUT0; 010: 6Bit_Matrix_OUT1; 011: 6Bit_Matrix_OUT2; 100: DM0_0; 101: DM0_1; 110: DM1_0; 111: DM1_1	
	1420			
	1421			
		1422	ASM Input Matrix (Signal Source for State 4 →State 2 Transition)	000: VSS; 001: 6Bit_Matrix_OUT0; 010: 6Bit_Matrix_OUT1; 011: 6Bit_Matrix_OUT2; 100: DM0_0; 101: DM0_1; 110: DM1_0; 111: DM1_1
	1423			
	1424			
B2		ASM Input Matrix (Signal Source for State 4 →State 3 Transition)	000: VSS; 001: 6Bit_Matrix_OUT0; 010: 6Bit_Matrix_OUT1; 011: 6Bit_Matrix_OUT2; 100: DM0_0; 101: DM0_1; 110: DM1_0; 111: DM1_1	
			1425	
			1426	
		1427	ASM Input Matrix (Signal Source for State 4 →State 4 Transition)	000: VSS; 001: 6Bit_Matrix_OUT0; 010: 6Bit_Matrix_OUT1; 011: 6Bit_Matrix_OUT2; 100: DM0_0; 101: DM0_1; 110: DM1_0; 111: DM1_1
		1428		
		1429		
		1430	ASM Input Matrix (Signal Source for State 4 →State 5 Transition)	000: VSS; 001: 6Bit_Matrix_OUT0; 010: 6Bit_Matrix_OUT1; 011: 6Bit_Matrix_OUT2; 100: DM0_0; 101: DM0_1; 110: DM1_0; 111: DM1_1
	1431			
	1432			
B3	1433		000: VSS; 001: 6Bit_Matrix_OUT0; 010: 6Bit_Matrix_OUT1; 011: 6Bit_Matrix_OUT2; 100: DM0_0; 101: DM0_1; 110: DM1_0; 111: DM1_1	

GreenPAK Programmable Mixed-Signal Matrix with Asynchronous State Machine and Dual Supply

Table 56: Register Map (Continued)

Address		Signal Function	Register Bit Definition
Byte	Register Bit		
B3	1434	ASM Input Matrix (Signal Source for State 4 →State 6 Transition)	000: VSS; 001: 6Bit_Matrix_OUT0; 010: 6Bit_Matrix_OUT1; 011: 6Bit_Matrix_OUT2; 100: DM0_0; 101: DM0_1; 110: DM1_0; 111: DM1_1
	1435		
	1436		
	1437	ASM Input Matrix (Signal Source for State 4 →State 7 Transition)	000: VSS; 001: 6Bit_Matrix_OUT0; 010: 6Bit_Matrix_OUT1; 011: 6Bit_Matrix_OUT2; 100: DM0_0; 101: DM0_1; 110: DM1_0; 111: DM1_1
	1438		
	1439		
B4	1440	ASM Input Matrix (Signal Source for State 4 →State 8 Transition)	000: VSS; 001: 6Bit_Matrix_OUT0; 010: 6Bit_Matrix_OUT1; 011: 6Bit_Matrix_OUT2; 100: DM0_0; 101: DM0_1; 110: DM1_0; 111: DM1_1
	1441		
	1442		
	1443	ASM Input Matrix (Signal Source for State 4 →State 9 Transition)	000: VSS; 001: 6Bit_Matrix_OUT0; 010: 6Bit_Matrix_OUT1; 011: 6Bit_Matrix_OUT2; 100: DM0_0; 101: DM0_1; 110: DM1_0; 111: DM1_1
	1444		
	1445		
B5	1446	ASM Input Matrix (Signal Source for State 4 →State 10 Transition)	000: VSS; 001: 6Bit_Matrix_OUT0; 010: 6Bit_Matrix_OUT1; 011: 6Bit_Matrix_OUT2; 100: DM0_0; 101: DM0_1; 110: DM1_0; 111: DM1_1
	1447		
	1448	ASM Input Matrix (Signal Source for State 4 →State 11 Transition)	000: VSS; 001: 6Bit_Matrix_OUT0; 010: 6Bit_Matrix_OUT1; 011: 6Bit_Matrix_OUT2; 100: DM0_0; 101: DM0_1; 110: DM1_0; 111: DM1_1
	1449		
	1450		
	1451		

GreenPAK Programmable Mixed-Signal Matrix with Asynchronous State Machine and Dual Supply

Table 56: Register Map (Continued)

Address		Signal Function	Register Bit Definition
Byte	Register Bit		
B5	1452	ASM Input Matrix (Signal Source for State 5 →State 10 Transition), bit [2] Note: This bit, along with registers [1487:1486], select the signal source for State 5 to State 10 Transition	000: VSS; 001: 6Bit_Matrix_OUT0; 010: 6Bit_Matrix_OUT1; 011: 6Bit_Matrix_OUT2; 100: DM0_0; 101: DM0_1; 110: DM1_0; 111: DM1_1
	1453	ASM Input Matrix (Signal Source for State 5 →State 11 Transition)	000: VSS; 001: 6Bit_Matrix_OUT0; 010: 6Bit_Matrix_OUT1; 011: 6Bit_Matrix_OUT2; 100: DM0_0; 101: DM0_1; 110: DM1_0; 111: DM1_1
	1454		
	1455		
B6	1456	ASM Input Matrix (Signal Source for State 5 →State 0 Transition)	000: VSS; 001: 6Bit_Matrix_OUT0; 010: 6Bit_Matrix_OUT1; 011: 6Bit_Matrix_OUT2; 100: DM0_0; 101: DM0_1; 110: DM1_0; 111: DM1_1
	1457		
	1458		
	1459	ASM Input Matrix (Signal Source for State 5 →State 1 Transition)	000: VSS; 001: 6Bit_Matrix_OUT0; 010: 6Bit_Matrix_OUT1; 011: 6Bit_Matrix_OUT2; 100: DM0_0; 101: DM0_1; 110: DM1_0; 111: DM1_1
	1460		
	1461		
	1462		
1463	ASM Input Matrix (Signal Source for State 5 →State 2 Transition)	000: VSS; 001: 6Bit_Matrix_OUT0; 010: 6Bit_Matrix_OUT1; 011: 6Bit_Matrix_OUT2; 100: DM0_0; 101: DM0_1; 110: DM1_0; 111: DM1_1	
B7			1464
			1465
1466			
	1467		

GreenPAK Programmable Mixed-Signal Matrix with Asynchronous State Machine and Dual Supply
Table 56: Register Map (Continued)

Address		Signal Function	Register Bit Definition
Byte	Register Bit		
B7	1468	ASM Input Matrix (Signal Source for State 5 →State 4 Transition)	000: VSS; 001: 6Bit_Matrix_OUT0; 010: 6Bit_Matrix_OUT1; 011: 6Bit_Matrix_OUT2; 100: DM0_0; 101: DM0_1; 110: DM1_0; 111: DM1_1
	1469		
	1470		
	1471		
B8	1472	ASM Input Matrix (Signal Source for State 5 →State 5 Transition)	000: VSS; 001: 6Bit_Matrix_OUT0; 010: 6Bit_Matrix_OUT1; 011: 6Bit_Matrix_OUT2; 100: DM0_0; 101: DM0_1; 110: DM1_0; 111: DM1_1
	1473		
	1474	ASM Input Matrix (Signal Source for State 5 →State 6 Transition)	000: VSS; 001: 6Bit_Matrix_OUT0; 010: 6Bit_Matrix_OUT1; 011: 6Bit_Matrix_OUT2; 100: DM0_0; 101: DM0_1; 110: DM1_0; 111: DM1_1
	1475		
	1476		
	1477	ASM Input Matrix (Signal Source for State 5 →State 7 Transition)	000: VSS; 001: 6Bit_Matrix_OUT0; 010: 6Bit_Matrix_OUT1; 011: 6Bit_Matrix_OUT2; 100: DM0_0; 101: DM0_1; 110: DM1_0; 111: DM1_1
	1478		
1479			

GreenPAK Programmable Mixed-Signal Matrix with Asynchronous State Machine and Dual Supply

Table 56: Register Map (Continued)

Address		Signal Function	Register Bit Definition
Byte	Register Bit		
B9	1480	ASM Input Matrix (Signal Source for State 5 →State 8 Transition)	000: VSS;
	1481		001: 6Bit_Matrix_OUT0;
	1482	010: 6Bit_Matrix_OUT1;	
		011: 6Bit_Matrix_OUT2;	
		100: DM0_0;	
		101: DM0_1;	
		110: DM1_0;	
		111: DM1_1	
	1483	ASM Input Matrix (Signal Source for State 5 →State 9 Transition)	000: VSS;
	1484		001: 6Bit_Matrix_OUT0;
	1485	010: 6Bit_Matrix_OUT1;	
		011: 6Bit_Matrix_OUT2;	
		100: DM0_0;	
		101: DM0_1;	
		110: DM1_0;	
		111: DM1_1	
	1486	ASM Input Matrix (Signal Source for State 5 →State 10 Transition), bits [1:0] Note: These bits, along with register [1452], select the signal source for State 5 to State 10 Transition	000: VSS;
	1487		001: 6Bit_Matrix_OUT0;
		010: 6Bit_Matrix_OUT1;	
		011: 6Bit_Matrix_OUT2;	
		100: DM0_0;	
		101: DM0_1;	
		110: DM1_0;	
		111: DM1_1	

GreenPAK Programmable Mixed-Signal Matrix with Asynchronous State Machine and Dual Supply

Table 56: Register Map (Continued)

Address		Signal Function	Register Bit Definition	
Byte	Register Bit			
BA	1488	ASM Input Matrix (Signal Source for State 6 →State 0 Transition)	000: VSS; 001: 6Bit_Matrix_OUT0; 010: 6Bit_Matrix_OUT1; 011: 6Bit_Matrix_OUT2; 100: DM0_0; 101: DM0_1; 110: DM1_0; 111: DM1_1	
	1489			
	1490			
	1491	ASM Input Matrix (Signal Source for State 6 →State 1 Transition)	000: VSS; 001: 6Bit_Matrix_OUT0; 010: 6Bit_Matrix_OUT1; 011: 6Bit_Matrix_OUT2; 100: DM0_0; 101: DM0_1; 110: DM1_0; 111: DM1_1	
	1492			
	1493			
	1494	ASM Input Matrix (Signal Source for State 6 →State 2 Transition)	000: VSS; 001: 6Bit_Matrix_OUT0; 010: 6Bit_Matrix_OUT1; 011: 6Bit_Matrix_OUT2; 100: DM0_0; 101: DM0_1; 110: DM1_0; 111: DM1_1	
	1495			
	1496			
BB		ASM Input Matrix (Signal Source for State 6 →State 3 Transition)	000: VSS; 001: 6Bit_Matrix_OUT0; 010: 6Bit_Matrix_OUT1; 011: 6Bit_Matrix_OUT2; 100: DM0_0; 101: DM0_1; 110: DM1_0; 111: DM1_1	
			1497	
			1498	
		1499	ASM Input Matrix (Signal Source for State 6 →State 4 Transition)	000: VSS; 001: 6Bit_Matrix_OUT0; 010: 6Bit_Matrix_OUT1; 011: 6Bit_Matrix_OUT2; 100: DM0_0; 101: DM0_1; 110: DM1_0; 111: DM1_1
		1500		
		1501		
	1502	ASM Input Matrix (Signal Source for State 6 →State 5 Transition)	000: VSS; 001: 6Bit_Matrix_OUT0; 010: 6Bit_Matrix_OUT1; 011: 6Bit_Matrix_OUT2; 100: DM0_0; 101: DM0_1; 110: DM1_0; 111: DM1_1	
	1503			
	1504			
BC		ASM Input Matrix (Signal Source for State 6 →State 6 Transition)	000: VSS; 001: 6Bit_Matrix_OUT0; 010: 6Bit_Matrix_OUT1; 011: 6Bit_Matrix_OUT2; 100: DM0_0; 101: DM0_1; 110: DM1_0; 111: DM1_1	
			1505	
		1506	ASM Input Matrix (Signal Source for State 6 →State 6 Transition)	000: VSS; 001: 6Bit_Matrix_OUT0; 010: 6Bit_Matrix_OUT1; 011: 6Bit_Matrix_OUT2; 100: DM0_0; 101: DM0_1; 110: DM1_0; 111: DM1_1
		1507		
	1508			

GreenPAK Programmable Mixed-Signal Matrix with Asynchronous
 State Machine and Dual Supply

Table 56: Register Map (Continued)

Address		Signal Function	Register Bit Definition
Byte	Register Bit		
BC	1509	ASM Input Matrix (Signal Source for State 6 →State 7 Transition)	000: VSS; 001: 6Bit_Matrix_OUT0; 010: 6Bit_Matrix_OUT1; 011: 6Bit_Matrix_OUT2; 100: DM0_0; 101: DM0_1; 110: DM1_0; 111: DM1_1
	1510		
	1511		

GreenPAK Programmable Mixed-Signal Matrix with Asynchronous
 State Machine and Dual Supply

Table 56: Register Map (Continued)

Address		Signal Function	Register Bit Definition	
Byte	Register Bit			
BD	1512	ASM Input Matrix (Signal Source for State 6 →State 8 Transition)	000: VSS; 001: 6Bit_Matrix_OUT0; 010: 6Bit_Matrix_OUT1; 011: 6Bit_Matrix_OUT2; 100: DM0_0; 101: DM0_1; 110: DM1_0; 111: DM1_1	
	1513			
	1514			
	1515	ASM Input Matrix (Signal Source for State 6 →State 9 Transition)	000: VSS; 001: 6Bit_Matrix_OUT0; 010: 6Bit_Matrix_OUT1; 011: 6Bit_Matrix_OUT2; 100: DM0_0; 101: DM0_1; 110: DM1_0; 111: DM1_1	
	1516			
	1517			
		1518	ASM Input Matrix (Signal Source for State 6 →State 10 Transition)	000: VSS; 001: 6Bit_Matrix_OUT0; 010: 6Bit_Matrix_OUT1; 011: 6Bit_Matrix_OUT2; 100: DM0_0; 101: DM0_1; 110: DM1_0; 111: DM1_1
	1519			
BE	1520	ASM Input Matrix (Signal Source for State 6 →State 11 Transition)	000: VSS; 001: 6Bit_Matrix_OUT0; 010: 6Bit_Matrix_OUT1; 011: 6Bit_Matrix_OUT2; 100: DM0_0; 101: DM0_1; 110: DM1_0; 111: DM1_1	
	1521			
	1522	ASM Input Matrix (Signal Source for State 6 →State 11 Transition)	000: VSS; 001: 6Bit_Matrix_OUT0; 010: 6Bit_Matrix_OUT1; 011: 6Bit_Matrix_OUT2; 100: DM0_0; 101: DM0_1; 110: DM1_0; 111: DM1_1	
	1523			
	1524		ASM Input Matrix (Signal Source for State 7 →State 10 Transition), bit [2] Note: This bit, along with registers [1559:1558], select the signal source for State 7 to State 10 Transition	
		1525	ASM Input Matrix (Signal Source for State 7 →State 11 Transition)	000: VSS; 001: 6Bit_Matrix_OUT0; 010: 6Bit_Matrix_OUT1; 011: 6Bit_Matrix_OUT2; 100: DM0_0; 101: DM0_1; 110: DM1_0; 111: DM1_1
		1526		
	1527			

GreenPAK Programmable Mixed-Signal Matrix with Asynchronous State Machine and Dual Supply

Table 56: Register Map (Continued)

Address		Signal Function	Register Bit Definition
Byte	Register Bit		
BF	1528	ASM Input Matrix (Signal Source for State 7 →State 0 Transition)	000: VSS; 001: 6Bit_Matrix_OUT0; 010: 6Bit_Matrix_OUT1; 011: 6Bit_Matrix_OUT2; 100: DM0_0; 101: DM0_1; 110: DM1_0; 111: DM1_1
	1529		
	1530		
	1531	ASM Input Matrix (Signal Source for State 7 →State 1 Transition)	000: VSS; 001: 6Bit_Matrix_OUT0; 010: 6Bit_Matrix_OUT1; 011: 6Bit_Matrix_OUT2; 100: DM0_0; 101: DM0_1; 110: DM1_0; 111: DM1_1
	1532		
	1533		
CO	1534	ASM Input Matrix (Signal Source for State 7 →State 2 Transition)	000: VSS; 001: 6Bit_Matrix_OUT0; 010: 6Bit_Matrix_OUT1; 011: 6Bit_Matrix_OUT2; 100: DM0_0; 101: DM0_1; 110: DM1_0; 111: DM1_1
	1535		
	1536		
	1537	ASM Input Matrix (Signal Source for State 7 →State 3 Transition)	000: VSS; 001: 6Bit_Matrix_OUT0; 010: 6Bit_Matrix_OUT1; 011: 6Bit_Matrix_OUT2; 100: DM0_0; 101: DM0_1; 110: DM1_0; 111: DM1_1
	1538		
	1539		
C1	1540	ASM Input Matrix (Signal Source for State 7 →State 4 Transition)	000: VSS; 001: 6Bit_Matrix_OUT0; 010: 6Bit_Matrix_OUT1; 011: 6Bit_Matrix_OUT2; 100: DM0_0; 101: DM0_1; 110: DM1_0; 111: DM1_1
	1541		
	1542		
	1543	ASM Input Matrix (Signal Source for State 7 →State 5 Transition)	000: VSS; 001: 6Bit_Matrix_OUT0; 010: 6Bit_Matrix_OUT1; 011: 6Bit_Matrix_OUT2; 100: DM0_0; 101: DM0_1; 110: DM1_0; 111: DM1_1
	1544		
	1545		
C1	1546	ASM Input Matrix (Signal Source for State 7 →State 6 Transition)	000: VSS; 001: 6Bit_Matrix_OUT0; 010: 6Bit_Matrix_OUT1; 011: 6Bit_Matrix_OUT2; 100: DM0_0; 101: DM0_1; 110: DM1_0; 111: DM1_1
	1547		
	1548		

GreenPAK Programmable Mixed-Signal Matrix with Asynchronous State Machine and Dual Supply

Table 56: Register Map (Continued)

Address		Signal Function	Register Bit Definition
Byte	Register Bit		
C1	1549	ASM Input Matrix (Signal Source for State 7 →State 7 Transition)	000: VSS; 001: 6Bit_Matrix_OUT0; 010: 6Bit_Matrix_OUT1; 011: 6Bit_Matrix_OUT2; 100: DM0_0; 101: DM0_1; 110: DM1_0; 111: DM1_1
	1550		
	1551		
C2	1552	ASM Input Matrix (Signal Source for State 7 →State 8 Transition)	000: VSS; 001: 6Bit_Matrix_OUT0; 010: 6Bit_Matrix_OUT1; 011: 6Bit_Matrix_OUT2; 100: DM0_0; 101: DM0_1; 110: DM1_0; 111: DM1_1
	1553		
	1554		
	1555	ASM Input Matrix (Signal Source for State 7 →State 9 Transition)	000: VSS; 001: 6Bit_Matrix_OUT0; 010: 6Bit_Matrix_OUT1; 011: 6Bit_Matrix_OUT2; 100: DM0_0; 101: DM0_1; 110: DM1_0; 111: DM1_1
	1556		
	1557		
	1558	ASM Input Matrix (Signal Source for State 7 →State 10 Transition), bits [1:0] Note: These bits, along with register [1524], select the signal source for State 7 to State 10 Transition	000: VSS; 001: 6Bit_Matrix_OUT0; 010: 6Bit_Matrix_OUT1; 011: 6Bit_Matrix_OUT2; 100: DM0_0; 101: DM0_1; 110: DM1_0; 111: DM1_1
1559			

GreenPAK Programmable Mixed-Signal Matrix with Asynchronous State Machine and Dual Supply

Table 56: Register Map (Continued)

Address		Signal Function	Register Bit Definition
Byte	Register Bit		
C3	1560	ASM Input Matrix (Signal Source for State 8 →State 0 Transition)	000: VSS; 001: 6Bit_Matrix_OUT0; 010: 6Bit_Matrix_OUT1; 011: 6Bit_Matrix_OUT2; 100: DM0_0; 101: DM0_1; 110: DM1_0; 111: DM1_1
	1561		
	1562		
	1563	ASM Input Matrix (Signal Source for State 8 →State 1 Transition)	000: VSS; 001: 6Bit_Matrix_OUT0; 010: 6Bit_Matrix_OUT1; 011: 6Bit_Matrix_OUT2; 100: DM0_0; 101: DM0_1; 110: DM1_0; 111: DM1_1
	1564		
	1565		
	1566	ASM Input Matrix (Signal Source for State 8 →State 2 Transition)	000: VSS; 001: 6Bit_Matrix_OUT0; 010: 6Bit_Matrix_OUT1; 011: 6Bit_Matrix_OUT2; 100: DM0_0; 101: DM0_1; 110: DM1_0; 111: DM1_1
1567			
C4	1568		

GreenPAK Programmable Mixed-Signal Matrix with Asynchronous State Machine and Dual Supply

Table 56: Register Map (Continued)

Address		Signal Function	Register Bit Definition
Byte	Register Bit		
C4	1569	ASM Input Matrix (Signal Source for State 8 →State 3 Transition)	000: VSS; 001: 6Bit_Matrix_OUT0; 010: 6Bit_Matrix_OUT1; 011: 6Bit_Matrix_OUT2; 100: DM0_0; 101: DM0_1; 110: DM1_0; 111: DM1_1
	1570		
	1571		
	1572	ASM Input Matrix (Signal Source for State 8 →State 4 Transition)	000: VSS; 001: 6Bit_Matrix_OUT0; 010: 6Bit_Matrix_OUT1; 011: 6Bit_Matrix_OUT2; 100: DM0_0; 101: DM0_1; 110: DM1_0; 111: DM1_1
	1573		
	1574		
C5	1575	ASM Input Matrix (Signal Source for State 8 →State 5 Transition)	000: VSS; 001: 6Bit_Matrix_OUT0; 010: 6Bit_Matrix_OUT1; 011: 6Bit_Matrix_OUT2; 100: DM0_0; 101: DM0_1; 110: DM1_0; 111: DM1_1
	1576		
	1577		
	1578	ASM Input Matrix (Signal Source for State 8 →State 6 Transition)	000: VSS; 001: 6Bit_Matrix_OUT0; 010: 6Bit_Matrix_OUT1; 011: 6Bit_Matrix_OUT2; 100: DM0_0; 101: DM0_1; 110: DM1_0; 111: DM1_1
	1579		
	1580		
	1581	ASM Input Matrix (Signal Source for State 8 →State 7 Transition)	000: VSS; 001: 6Bit_Matrix_OUT0; 010: 6Bit_Matrix_OUT1; 011: 6Bit_Matrix_OUT2; 100: DM0_0; 101: DM0_1; 110: DM1_0; 111: DM1_1
	1582		
1583			

GreenPAK Programmable Mixed-Signal Matrix with Asynchronous State Machine and Dual Supply

Table 56: Register Map (Continued)

Address		Signal Function	Register Bit Definition
Byte	Register Bit		
C6	1584	ASM Input Matrix (Signal Source for State 8 →State 8 Transition)	000: VSS; 001: 6Bit_Matrix_OUT0; 010: 6Bit_Matrix_OUT1; 011: 6Bit_Matrix_OUT2; 100: DM0_0; 101: DM0_1; 110: DM1_0; 111: DM1_1
	1585		
	1586		
	1587	ASM Input Matrix (Signal Source for State 8 →State 9 Transition)	000: VSS; 001: 6Bit_Matrix_OUT0; 010: 6Bit_Matrix_OUT1; 011: 6Bit_Matrix_OUT2; 100: DM0_0; 101: DM0_1; 110: DM1_0; 111: DM1_1
	1588		
	1589		
C6	1590	ASM Input Matrix (Signal Source for State 8 →State 10 Transition)	000: VSS; 001: 6Bit_Matrix_OUT0; 010: 6Bit_Matrix_OUT1; 011: 6Bit_Matrix_OUT2; 100: DM0_0; 101: DM0_1; 110: DM1_0; 111: DM1_1
	1591		
C7	1592	ASM Input Matrix (Signal Source for State 8 →State 11 Transition)	000: VSS; 001: 6Bit_Matrix_OUT0; 010: 6Bit_Matrix_OUT1; 011: 6Bit_Matrix_OUT2; 100: DM0_0; 101: DM0_1; 110: DM1_0; 111: DM1_1
	1593		
	1594		
	1595	ASM Input Matrix (Signal Source for State 9 →State 10 Transition), bit [2] Note: This bit, along with registers [1631:1630], select the signal source for State 9 to State 10 Transition	000: VSS; 001: 6Bit_Matrix_OUT0; 010: 6Bit_Matrix_OUT1; 011: 6Bit_Matrix_OUT2; 100: DM0_0; 101: DM0_1; 110: DM1_0; 111: DM1_1
	1596		
	1597		
	1598	ASM Input Matrix (Signal Source for State 9 →State 11 Transition)	000: VSS; 001: 6Bit_Matrix_OUT0; 010: 6Bit_Matrix_OUT1; 011: 6Bit_Matrix_OUT2; 100: DM0_0; 101: DM0_1; 110: DM1_0; 111: DM1_1
1599			

GreenPAK Programmable Mixed-Signal Matrix with Asynchronous State Machine and Dual Supply

Table 56: Register Map (Continued)

Address		Signal Function	Register Bit Definition
Byte	Register Bit		
C8	1600	ASM Input Matrix (Signal Source for State 9 →State 0 Transition)	000: VSS; 001: 6Bit_Matrix_OUT0; 010: 6Bit_Matrix_OUT1; 011: 6Bit_Matrix_OUT2; 100: DM0_0; 101: DM0_1; 110: DM1_0; 111: DM1_1
	1601		
	1602		
	1603	ASM Input Matrix (Signal Source for State 9 →State 1 Transition)	000: VSS; 001: 6Bit_Matrix_OUT0; 010: 6Bit_Matrix_OUT1; 011: 6Bit_Matrix_OUT2; 100: DM0_0; 101: DM0_1; 110: DM1_0; 111: DM1_1
	1604		
	1605		
	1606	ASM Input Matrix (Signal Source for State 9 →State 2 Transition)	000: VSS; 001: 6Bit_Matrix_OUT0; 010: 6Bit_Matrix_OUT1; 011: 6Bit_Matrix_OUT2; 100: DM0_0; 101: DM0_1; 110: DM1_0; 111: DM1_1
1607			
C9	1608		

GreenPAK Programmable Mixed-Signal Matrix with Asynchronous State Machine and Dual Supply
Table 56: Register Map (Continued)

Address		Signal Function	Register Bit Definition
Byte	Register Bit		
C9	1609	ASM Input Matrix (Signal Source for State 9 →State 3 Transition)	000: VSS; 001: 6Bit_Matrix_OUT0; 010: 6Bit_Matrix_OUT1; 011: 6Bit_Matrix_OUT2; 100: DM0_0; 101: DM0_1; 110: DM1_0; 111: DM1_1
	1610		
	1611		
	1612	ASM Input Matrix (Signal Source for State 9 →State 4 Transition)	000: VSS; 001: 6Bit_Matrix_OUT0; 010: 6Bit_Matrix_OUT1; 011: 6Bit_Matrix_OUT2; 100: DM0_0; 101: DM0_1; 110: DM1_0; 111: DM1_1
	1613		
	1614		
CA	1615	ASM Input Matrix (Signal Source for State 9 →State 5 Transition)	000: VSS; 001: 6Bit_Matrix_OUT0; 010: 6Bit_Matrix_OUT1; 011: 6Bit_Matrix_OUT2; 100: DM0_0; 101: DM0_1; 110: DM1_0; 111: DM1_1
	1616		
	1617		
	1618	ASM Input Matrix (Signal Source for State 9 →State 6 Transition)	000: VSS; 001: 6Bit_Matrix_OUT0; 010: 6Bit_Matrix_OUT1; 011: 6Bit_Matrix_OUT2; 100: DM0_0; 101: DM0_1; 110: DM1_0; 111: DM1_1
	1619		
	1620		
	1621	ASM Input Matrix (Signal Source for State 9 →State 7 Transition)	000: VSS; 001: 6Bit_Matrix_OUT0; 010: 6Bit_Matrix_OUT1; 011: 6Bit_Matrix_OUT2; 100: DM0_0; 101: DM0_1; 110: DM1_0; 111: DM1_1
	1622		
1623			

GreenPAK Programmable Mixed-Signal Matrix with Asynchronous State Machine and Dual Supply
Table 56: Register Map (Continued)

Address		Signal Function	Register Bit Definition
Byte	Register Bit		
CB	1624	ASM Input Matrix (Signal Source for State 9 →State 8 Transition)	000: VSS; 001: 6Bit_Matrix_OUT0; 010: 6Bit_Matrix_OUT1; 011: 6Bit_Matrix_OUT2; 100: DM0_0; 101: DM0_1; 110: DM1_0; 111: DM1_1
	1625		
	1626		
	1627	ASM Input Matrix (Signal Source for State 9 →State 9 Transition)	000: VSS; 001: 6Bit_Matrix_OUT0; 010: 6Bit_Matrix_OUT1; 011: 6Bit_Matrix_OUT2; 100: DM0_0; 101: DM0_1; 110: DM1_0; 111: DM1_1
	1628		
	1629		
CB	1630	ASM Input Matrix (Signal Source for State 9 →State 10 Transition), bits [1:0] Note: These bits, along with register [1596], select the signal source for State 9 to State 10 Transition	000: VSS; 001: 6Bit_Matrix_OUT0; 010: 6Bit_Matrix_OUT1; 011: 6Bit_Matrix_OUT2; 100: DM0_0; 101: DM0_1; 110: DM1_0; 111: DM1_1
	1631		

GreenPAK Programmable Mixed-Signal Matrix with Asynchronous State Machine and Dual Supply

Table 56: Register Map (Continued)

Address		Signal Function	Register Bit Definition
Byte	Register Bit		
CC	1632	ASM Input Matrix (Signal Source for State 10 →State 0 Transition)	000: VSS;
	1633		001: 6Bit_Matrix_OUT0;
	1634		010: 6Bit_Matrix_OUT1;
	1635	ASM Input Matrix (Signal Source for State 10 →State 1 Transition)	011: 6Bit_Matrix_OUT2;
	1636		100: DM0_0;
	1637		101: DM0_1;
1638	ASM Input Matrix (Signal Source for State 10 →State 2 Transition)	110: DM1_0;	
1639		111: DM1_1	
CD	1640	ASM Input Matrix (Signal Source for State 10 →State 3 Transition)	000: VSS;
	1641		001: 6Bit_Matrix_OUT0;
	1642	ASM Input Matrix (Signal Source for State 10 →State 4 Transition)	010: 6Bit_Matrix_OUT1;
	1643		011: 6Bit_Matrix_OUT2;
	1644		100: DM0_0;
	1645	ASM Input Matrix (Signal Source for State 10 →State 5 Transition)	101: DM0_1;
1646	110: DM1_0;		
CE	1647	ASM Input Matrix (Signal Source for State 10 →State 5 Transition)	111: DM1_1
	1648		000: VSS;
CE	1649	001: 6Bit_Matrix_OUT0;	
			010: 6Bit_Matrix_OUT1;
			011: 6Bit_Matrix_OUT2;
			100: DM0_0;
			101: DM0_1;
			110: DM1_0;
			111: DM1_1

GreenPAK Programmable Mixed-Signal Matrix with Asynchronous State Machine and Dual Supply
Table 56: Register Map (Continued)

Address		Signal Function	Register Bit Definition
Byte	Register Bit		
CE	1650	ASM Input Matrix (Signal Source for State 10 →State 6 Transition)	000: VSS;
	1651		001: 6Bit_Matrix_OUT0;
	1652		010: 6Bit_Matrix_OUT1;
	1653	011: 6Bit_Matrix_OUT2;	
	1654	100: DM0_0;	
	1655	101: DM0_1;	
			110: DM1_0;
			111: DM1_1
		ASM Input Matrix (Signal Source for State 10 →State 7 Transition)	000: VSS;
			001: 6Bit_Matrix_OUT0;
			010: 6Bit_Matrix_OUT1;
			011: 6Bit_Matrix_OUT2;
			100: DM0_0;
			101: DM0_1;
			110: DM1_0;
			111: DM1_1

GreenPAK Programmable Mixed-Signal Matrix with Asynchronous State Machine and Dual Supply

Table 56: Register Map (Continued)

Address		Signal Function	Register Bit Definition
Byte	Register Bit		
CF	1656	ASM Input Matrix (Signal Source for State 10 →State 8 Transition)	000: VSS; 001: 6Bit_Matrix_OUT0; 010: 6Bit_Matrix_OUT1; 011: 6Bit_Matrix_OUT2; 100: DM0_0; 101: DM0_1; 110: DM1_0; 111: DM1_1
	1657		
	1658		
	1659	ASM Input Matrix (Signal Source for State 10 →State 9 Transition)	000: VSS; 001: 6Bit_Matrix_OUT0; 010: 6Bit_Matrix_OUT1; 011: 6Bit_Matrix_OUT2; 100: DM0_0; 101: DM0_1; 110: DM1_0; 111: DM1_1
	1660		
	1661		
		1662	ASM Input Matrix (Signal Source for State 10 →State 10 Transition)
	1663		
	1664		
D0		ASM Input Matrix (Signal Source for State 10 →State 11 Transition)	000: VSS; 001: 6Bit_Matrix_OUT0; 010: 6Bit_Matrix_OUT1; 011: 6Bit_Matrix_OUT2; 100: DM0_0; 101: DM0_1; 110: DM1_0; 111: DM1_1
			1665
		1666	
		1667	
	1668	ASM Input Matrix (Signal Source for State 11 →State 10 Transition), bit [2] Note: This bit, along with registers [1703:1702], select the signal source for State 11 to State 10 Transition	000: VSS; 001: 6Bit_Matrix_OUT0; 010: 6Bit_Matrix_OUT1; 011: 6Bit_Matrix_OUT2; 100: DM0_0; 101: DM0_1; 110: DM1_0; 111: DM1_1
D0	1669	ASM Input Matrix (Signal Source for State 11 →State 11 Transition)	000: VSS; 001: 6Bit_Matrix_OUT0; 010: 6Bit_Matrix_OUT1; 011: 6Bit_Matrix_OUT2; 100: DM0_0; 101: DM0_1; 110: DM1_0; 111: DM1_1
	1670		
	1671		

GreenPAK Programmable Mixed-Signal Matrix with Asynchronous State Machine and Dual Supply

Table 56: Register Map (Continued)

Address		Signal Function	Register Bit Definition
Byte	Register Bit		
D1	1672	ASM Input Matrix (Signal Source for State 11 →State 0 Transition)	000: VSS; 001: 6Bit_Matrix_OUT0; 010: 6Bit_Matrix_OUT1; 011: 6Bit_Matrix_OUT2; 100: DM0_0; 101: DM0_1; 110: DM1_0; 111: DM1_1
	1673		
	1674		
	1675	ASM Input Matrix (Signal Source for State 11 →State 1 Transition)	000: VSS; 001: 6Bit_Matrix_OUT0; 010: 6Bit_Matrix_OUT1; 011: 6Bit_Matrix_OUT2; 100: DM0_0; 101: DM0_1; 110: DM1_0; 111: DM1_1
	1676		
	1677		
		1678	ASM Input Matrix (Signal Source for State 11 →State 2 Transition)
	1679		
D2	1680	ASM Input Matrix (Signal Source for State 11 →State 3 Transition)	000: VSS; 001: 6Bit_Matrix_OUT0; 010: 6Bit_Matrix_OUT1; 011: 6Bit_Matrix_OUT2; 100: DM0_0; 101: DM0_1; 110: DM1_0; 111: DM1_1
	1681		
	1682		
	1683	ASM Input Matrix (Signal Source for State 11 →State 4 Transition)	000: VSS; 001: 6Bit_Matrix_OUT0; 010: 6Bit_Matrix_OUT1; 011: 6Bit_Matrix_OUT2; 100: DM0_0; 101: DM0_1; 110: DM1_0; 111: DM1_1
	1684		
	1685		
1686	ASM Input Matrix (Signal Source for State 11 →State 5 Transition)	000: VSS; 001: 6Bit_Matrix_OUT0; 010: 6Bit_Matrix_OUT1; 011: 6Bit_Matrix_OUT2; 100: DM0_0; 101: DM0_1; 110: DM1_0; 111: DM1_1	
1687			
D3	1688	ASM Input Matrix (Signal Source for State 11 →State 5 Transition)	000: VSS; 001: 6Bit_Matrix_OUT0; 010: 6Bit_Matrix_OUT1; 011: 6Bit_Matrix_OUT2; 100: DM0_0; 101: DM0_1; 110: DM1_0; 111: DM1_1
	1689		

GreenPAK Programmable Mixed-Signal Matrix with Asynchronous State Machine and Dual Supply

Table 56: Register Map (Continued)

Address		Signal Function	Register Bit Definition
Byte	Register Bit		
D3	1690	ASM Input Matrix (Signal Source for State 11 →State 6 Transition)	000: VSS; 001: 6Bit_Matrix_OUT0; 010: 6Bit_Matrix_OUT1; 011: 6Bit_Matrix_OUT2; 100: DM0_0; 101: DM0_1; 110: DM1_0; 111: DM1_1
	1691		
	1692		
	1693	ASM Input Matrix (Signal Source for State 11 →State 7 Transition)	000: VSS; 001: 6Bit_Matrix_OUT0; 010: 6Bit_Matrix_OUT1; 011: 6Bit_Matrix_OUT2; 100: DM0_0; 101: DM0_1; 110: DM1_0; 111: DM1_1
	1694		
	1695		
D4	1696	ASM Input Matrix (Signal Source for State 11 →State 8 Transition)	000: VSS; 001: 6Bit_Matrix_OUT0; 010: 6Bit_Matrix_OUT1; 011: 6Bit_Matrix_OUT2; 100: DM0_0; 101: DM0_1; 110: DM1_0; 111: DM1_1
	1697		
	1698		
	1699	ASM Input Matrix (Signal Source for State 11 →State 9 Transition)	000: VSS; 001: 6Bit_Matrix_OUT0; 010: 6Bit_Matrix_OUT1; 011: 6Bit_Matrix_OUT2; 100: DM0_0; 101: DM0_1; 110: DM1_0; 111: DM1_1
	1700		
	1701		
	1702	ASM Input Matrix (Signal Source for State 11 →State 10 Transition), bits [1:0] Note: These bits, along with register [1668], select the signal source for State 11 to State 10 Transition	000: VSS; 001: 6Bit_Matrix_OUT0; 010: 6Bit_Matrix_OUT1; 011: 6Bit_Matrix_OUT2; 100: DM0_0; 101: DM0_1; 110: DM1_0; 111: DM1_1
1703			

GreenPAK Programmable Mixed-Signal Matrix with Asynchronous State Machine and Dual Supply

Table 56: Register Map (Continued)

Address		Signal Function	Register Bit Definition
Byte	Register Bit		
D5	1704	DM0_0 Configuration Register 0 IN0 of LUT3	REG_MATRIX_LUT3_IN0_SEL[5:0]
	1705		
	1706		
	1707		
	1708		
	1709		
	1710		
D6	1711	DM0_0 Configuration Register 0 IN1 of LUT3	REG_MATRIX_LUT3_IN1_SEL[5:0]
	1712		
	1713		
	1714		
D6	1715	DM0_0 Configuration Register 0 IN2 of LUT3	REG_MATRIX_LUT3_IN2_SEL[5:0]
	1716		
	1717		
	1718		
D7	1719	DM0_0 Configuration Register 0 DLY input from matrix	DM Delay input
	1720		
	1721		
	1722		
	1723		
	1724		
	1725		
D8	1726	DM0_0 Configuration Register 0 Data of LUT3	REG_VAL_LUT3[0]
	1727		
	1728		
	1729		
	1730		
	1731		
	1732		
	1733		
1734			
1735			

GreenPAK Programmable Mixed-Signal Matrix with Asynchronous State Machine and Dual Supply

Table 56: Register Map (Continued)

Address		Signal Function	Register Bit Definition
Byte	Register Bit		
D9	1736	DM0_0 Configuration Register 0 Data of LUT2	REG_VAL_LUT2[0]
	1737		REG_VAL_LUT2[1]
	1738		REG_VAL_LUT2[2]
	1739		REG_VAL_LUT2[3]
	1740	DM0_0 Configuration Register 0 Clock source selection	Clock source sel[3:0]
	1741		0000: 25M; 0001: 25M/4; 0010: 2.048M 0011: 2.048M/8; 0100: 2.048M/64; 0101: 2.048M/512; 0110: 2.048K; 0111: 2.048K/8; 1000: 2.048K/64; 1001: 2.048K/512; 1010: 2.048K/4096 1011: 2.048K/32768; 1100: 2.048K/262144; 1101: CNT_END; 1110: External; 1111: External
	1742		
	1743		
DA	1744	DM0_0 Configuration Register 0 Data of Delay	Data[7:0]
	1745		
	1746		
	1747		
	1748		
	1749		
	1750		
1751			

GreenPAK Programmable Mixed-Signal Matrix with Asynchronous State Machine and Dual Supply

Table 56: Register Map (Continued)

Address		Signal Function	Register Bit Definition
Byte	Register Bit		
DB	1752	DM0_0 Configuration Register 0 DLY input initial selection	00: bypass the initial 01: initial 0 10: initial 1 11: initial 1
	1753		
	1754	DM0_0 Configuration Register 0 DLY/CNT Function selection	0000: Both Edge Delay 0001: Falling Edge Delay 0010: Rising Edge Delay 0011: Both Edge One Shot 0100: Falling Edge One Shot 0101: Rising Edge One Shot 0110: Both Edge Freq Detect 0111: Falling Edge Freq Detect 1000: Rising Edge Freq Detect 1001: Both Edge Detect 1010: Falling Edge Detect 1011: Rising Edge Detect 1100: Both Edge Reset CNT 1101: Falling Edge Reset CNT 1110: Rising Edge Reset CNT 1111: High Level Reset CNT
	1755		
	1756		
	1757		
	1758	DM0_0 Configuration Register 0 MUX1 selection for LUT2	0: from LUT3 1: from matrix (DLY IN)
1759	DM0_0 Configuration Register 0 MUX2 selection for DLY input	0: from matrix (DLY IN) 1: from LUT3	
DC	1760	DM0_0 Configuration Register 1 IN0 of LUT3	REG_MATRIX_LUT3_IN0_SEL[5:0]
	1761		
	1762		
	1763		
	1764		
	1765		
	1766		
DD	1767	DM0_0 Configuration Register 1 IN1 of LUT3	REG_MATRIX_LUT3_IN1_SEL[5:0]
	1768		
	1769		
	1770		
	1771		

GreenPAK Programmable Mixed-Signal Matrix with Asynchronous State Machine and Dual Supply

Table 56: Register Map (Continued)

Address		Signal Function	Register Bit Definition	
Byte	Register Bit			
DD	1772	DM0_0 Configuration Register 1 IN2 of LUT3	REG_MATRIX_LUT3_IN2_SEL[5:0]	
	1773			
	1774			
	1775			
DE	1776	DM0_0 Configuration Register 1 DLY input from matrix	DM Delay input	
	1777			
	1778			
	1779			
	1780			
	1781			
DF	1782	DM0_0 Configuration Register 1 Data of LUT3	REG_VAL_LUT3[0]	
	1783			REG_VAL_LUT3[1]
	1784			REG_VAL_LUT3[2]
	1785			REG_VAL_LUT3[3]
	1786			REG_VAL_LUT3[4]
	1787			REG_VAL_LUT3[5]
	1788			REG_VAL_LUT3[6]
	1789			REG_VAL_LUT3[7]
E0	1790	DM0_0 Configuration Register 1 Data of LUT2	REG_VAL_LUT2[0]	
	1791		REG_VAL_LUT2[1]	
	1792		REG_VAL_LUT2[2]	
	1793		REG_VAL_LUT2[3]	
	1794		Clock source sel[3:0] 0000: 25M; 0001: 25M/4; 0010: 2.048M 0011: 2.048M/8; 0100: 2.048M/64; 0101: 2.048M/512; 0110: 2.048K; 0111: 2.048K/8; 1000: 2.048K/64; 1001: 2.048K/512; 1010: 2.048K/4096 1011: 2.048K/32768; 1100: 2.048K/262144; 1101: CNT_END; 1110: External; 1111: External	
	1795			
	1796			
1797	DM0_0 Configuration Register 1 Clock source selection	1799		
1798				

GreenPAK Programmable Mixed-Signal Matrix with Asynchronous State Machine and Dual Supply

Table 56: Register Map (Continued)

Address		Signal Function	Register Bit Definition
Byte	Register Bit		
E1	1800	DM0_0 Configuration Register 1 Data of Delay	Data[7:0]
	1801		
	1802		
	1803		
	1804		
	1805		
	1806		
	1807		
E2	1808	DM0_0 Configuration Register 1 DLY input initial selection	00: bypass the initial 01: initial 0 10: initial 1 11: initial 1
	1809		
	1810	DM0_0 Configuration Register 1 DLY/CNT Function selection	0000: Both Edge Delay 0001: Falling Edge Delay 0010: Rising Edge Delay 0011: Both Edge One Shot 0100: Falling Edge One Shot 0101: Rising Edge One Shot 0110: Both Edge Freq Detect 0111: Falling Edge Freq Detect 1000: Rising Edge Freq Detect 1001: Both Edge Detect 1010: Falling Edge Detect 1011: Rising Edge Detect 1100: Both Edge Reset CNT 1101: Falling Edge Reset CNT 1110: Rising Edge Reset CNT 1111: High Level Reset CNT
	1811		
	1812		
	1813		
	1814		
1815	DM0_0 Configuration Register 1 MUX2 selection for DLY input	0: from matrix (DLY IN) 1: from LUT3	
E3	1816	DM0_0 Configuration Register 2 IN0 of LUT3	REG_MATRIX_LUT3_IN0_SEL[5:0]
	1817		
	1818		
	1819		
	1820		
	1821		
	1822	DM0_0 Configuration Register 2 IN1 of LUT3	REG_MATRIX_LUT3_IN1_SEL[5:0]
1823			
E4	1824	DM0_0 Configuration Register 2 IN1 of LUT3	REG_MATRIX_LUT3_IN1_SEL[5:0]
	1825		
	1826		
	1827		

GreenPAK Programmable Mixed-Signal Matrix with Asynchronous State Machine and Dual Supply

Table 56: Register Map (Continued)

Address		Signal Function	Register Bit Definition
Byte	Register Bit		
E4	1828	DM0_0 Configuration Register 2 IN2 of LUT3	REG_MATRIX_LUT3_IN2_SEL[5:0]
	1829		
	1830		
	1831		
E5	1832	DM0_0 Configuration Register 2 DLY input from matrix	DM Delay input
	1833		
	1834		
	1835		
	1836		
	1837		
	1838		
E6	1840	DM0_0 Configuration Register 2 Data of LUT3	REG_VAL_LUT3[0]
	1841		REG_VAL_LUT3[1]
	1842		REG_VAL_LUT3[2]
	1843		REG_VAL_LUT3[3]
	1844		REG_VAL_LUT3[4]
	1845		REG_VAL_LUT3[5]
	1846		REG_VAL_LUT3[6]
	1847		REG_VAL_LUT3[7]
E7	1848	DM0_0 Configuration Register 2 Data of LUT2	REG_VAL_LUT2[0]
	1849		REG_VAL_LUT2[1]
	1850		REG_VAL_LUT2[2]
	1851		REG_VAL_LUT2[3]
	1852	DM0_0 Configuration Register 2 Clock source selection	Clock source sel[3:0] 0000: 25M; 0001: 25M/4; 0010: 2.048M 0011: 2.048M/8; 0100: 2.048M/64; 0101: 2.048M/512; 0110: 2.048K; 0111: 2.048K/8; 1000: 2.048K/64; 1001: 2.048K/512; 1010: 2.048K/4096 1011: 2.048K/32768; 1100: 2.048K/262144; 1101: CNT_END; 1110: External; 1111: External
	1853		
	1854		
	1855		

GreenPAK Programmable Mixed-Signal Matrix with Asynchronous State Machine and Dual Supply

Table 56: Register Map (Continued)

Address		Signal Function	Register Bit Definition
Byte	Register Bit		
E8	1856	DM0_0 Configuration Register 2 Data of Delay	Data[7:0]
	1857		
	1858		
	1859		
	1860		
	1861		
	1862		
E9	1863	DM0_0 Configuration Register 2 DLY/CNT Function selection	00: bypass the initial 01: initial 0 10: initial 1 11: initial 1 0000: Both Edge Delay 0001: Falling Edge Delay 0010: Rising Edge Delay 0011: Both Edge One Shot 0100: Falling Edge One Shot 0101: Rising Edge One Shot 0110: Both Edge Freq Detect 0111: Falling Edge Freq Detect 1000: Rising Edge Freq Detect 1001: Both Edge Detect 1010: Falling Edge Detect 1011: Rising Edge Detect 1100: Both Edge Reset CNT 1101: Falling Edge Reset CNT 1110: Rising Edge Reset CNT 1111: High Level Reset CNT
	1864		
	1865		
	1866		
	1867		
	1868		
	1869		
EA	1870	DM0_0 Configuration Register 2 MUX1 selection for LUT2	0: from LUT3 1: from matrix (DLY IN)
	1871	DM0_0 Configuration Register 2 MUX2 selection for DLY input	0: from matrix (DLY IN) 1: from LUT3
	1872	DM0_0 Configuration Register 3 IN0 of LUT3	REG_MATRIX_LUT3_IN0_SEL[5:0]
1873			
1874			
1875			
1876			
EB	1877	DM0_0 Configuration Register 3 IN1 of LUT3	REG_MATRIX_LUT3_IN1_SEL[5:0]
	1878		
	1879		
	1880		
EB	1881	DM0_0 Configuration Register 3 IN1 of LUT3	REG_MATRIX_LUT3_IN1_SEL[5:0]
	1882		
	1883		
	1884		

GreenPAK Programmable Mixed-Signal Matrix with Asynchronous State Machine and Dual Supply

Table 56: Register Map (Continued)

Address		Signal Function	Register Bit Definition
Byte	Register Bit		
EB	1884	DM0_0 Configuration Register 3 IN2 of LUT3	REG_MATRIX_LUT3_IN2_SEL[5:0]
	1885		
	1886		
	1887		
EC	1888	DM0_0 Configuration Register 3 DLY input from matrix	DM Delay input
	1889		
	1890		
	1891		
	1892		
	1893		
	1894		
ED	1896	DM0_0 Configuration Register 3 Data of LUT3	REG_VAL_LUT3[0]
	1897		REG_VAL_LUT3[1]
	1898		REG_VAL_LUT3[2]
	1899		REG_VAL_LUT3[3]
	1900		REG_VAL_LUT3[4]
	1901		REG_VAL_LUT3[5]
	1902		REG_VAL_LUT3[6]
	1903		REG_VAL_LUT3[7]
EE	1904	DM0_0 Configuration Register 3 Data of LUT2	REG_VAL_LUT2[0]
	1905		REG_VAL_LUT2[1]
	1906		REG_VAL_LUT2[2]
	1907		REG_VAL_LUT2[3]
	1908	DM0_0 Configuration Register 3 Clock source selection	Clock source sel[3:0] 0000: 25M; 0001: 25M/4; 0010: 2.048M 0011: 2.048M/8; 0100: 2.048M/64; 0101: 2.048M/512; 0110: 2.048K; 0111: 2.048K/8; 1000: 2.048K/64; 1001: 2.048K/512; 1010: 2.048K/4096 1011: 2.048K/32768; 1100: 2.048K/262144; 1101: CNT_END; 1110: External; 1111: External
	1909		
	1910		
	1911		

GreenPAK Programmable Mixed-Signal Matrix with Asynchronous State Machine and Dual Supply

Table 56: Register Map (Continued)

Address		Signal Function	Register Bit Definition
Byte	Register Bit		
EF	1912	DM0_0 Configuration Register 3 Data of Delay	Data[7:0]
	1913		
	1914		
	1915		
	1916		
	1917		
	1918		
	1919		
F0	1920	DM0_0 Configuration Register 3 DLY input initial selection	00: bypass the initial 01: initial 0 10: initial 1 11: initial 1
	1921		
	1922	DM0_0 Configuration Register 3 DLY/CNT Function selection	0000: Both Edge Delay 0001: Falling Edge Delay 0010: Rising Edge Delay 0011: Both Edge One Shot 0100: Falling Edge One Shot 0101: Rising Edge One Shot 0110: Both Edge Freq Detect 0111: Falling Edge Freq Detect 1000: Rising Edge Freq Detect 1001: Both Edge Detect 1010: Falling Edge Detect 1011: Rising Edge Detect 1100: Both Edge Reset CNT 1101: Falling Edge Reset CNT 1110: Rising Edge Reset CNT 1111: High Level Reset CNT
	1923		
	1924		
	1925		
	1926	DM0_0 Configuration Register 3 MUX1 selection for LUT2	0: from LUT3 1: from matrix (DLY IN)
	1927	DM0_0 Configuration Register 3 MUX2 selection for DLY input	0: from matrix (DLY IN) 1: from LUT3
F1	1928	DM0_0 Configuration Register 4 IN0 of LUT3	REG_MATRIX_LUT3_IN0_SEL[5:0]
	1929		
	1930		
	1931		
	1932		
	1933		
	1934	DM0_0 Configuration Register 4 IN1 of LUT3	REG_MATRIX_LUT3_IN1_SEL[5:0]
	1935		
F2	1936	DM0_0 Configuration Register 4 IN1 of LUT3	REG_MATRIX_LUT3_IN1_SEL[5:0]
	1937		
	1938		
	1939		

GreenPAK Programmable Mixed-Signal Matrix with Asynchronous State Machine and Dual Supply

Table 56: Register Map (Continued)

Address		Signal Function	Register Bit Definition
Byte	Register Bit		
F2	1940	DM0_0 Configuration Register 4 IN2 of LUT3	REG_MATRIX_LUT3_IN2_SEL[5:0]
	1941		
	1942		
	1943		
F3	1944	DM0_0 Configuration Register 4 DLY input from matrix	DM Delay input
	1945		
	1946		
	1947		
	1948		
	1949		
F4	1952	DM0_0 Configuration Register 4 Data of LUT3	REG_VAL_LUT3[0]
	1953		REG_VAL_LUT3[1]
	1954		REG_VAL_LUT3[2]
	1955		REG_VAL_LUT3[3]
	1956		REG_VAL_LUT3[4]
	1957		REG_VAL_LUT3[5]
	1958		REG_VAL_LUT3[6]
	1959		REG_VAL_LUT3[7]
F5	1960	DM0_0 Configuration Register 4 Data of LUT2	REG_VAL_LUT2[0]
	1961		REG_VAL_LUT2[1]
	1962		REG_VAL_LUT2[2]
	1963		REG_VAL_LUT2[3]
	1964	DM0_0 Configuration Register 4 Clock source selection	Clock source sel[3:0] 0000: 25M; 0001: 25M/4; 0010: 2.048M 0011: 2.048M/8; 0100: 2.048M/64; 0101: 2.048M/512; 0110: 2.048K; 0111: 2.048K/8; 1000: 2.048K/64; 1001: 2.048K/512; 1010: 2.048K/4096 1011: 2.048K/32768; 1100: 2.048K/262144; 1101: CNT_END; 1110: External; 1111: External
	1965		
	1966		
	1967		

GreenPAK Programmable Mixed-Signal Matrix with Asynchronous State Machine and Dual Supply

Table 56: Register Map (Continued)

Address		Signal Function	Register Bit Definition
Byte	Register Bit		
F6	1968	DM0_0 Configuration Register 4 Data of Delay	Data[7:0]
	1969		
	1970		
	1971		
	1972		
	1973		
	1974		
	1975		
F7	1976	DM0_0 Configuration Register 4 DLY input initial selection	00: bypass the initial 01: initial 0 10: initial 1 11: initial 1
	1977		
	1978	DM0_0 Configuration Register 4 DLY/CNT Function selection	0000: Both Edge Delay 0001: Falling Edge Delay 0010: Rising Edge Delay 0011: Both Edge One Shot 0100: Falling Edge One Shot 0101: Rising Edge One Shot 0110: Both Edge Freq Detect 0111: Falling Edge Freq Detect 1000: Rising Edge Freq Detect 1001: Both Edge Detect 1010: Falling Edge Detect 1011: Rising Edge Detect 1100: Both Edge Reset CNT 1101: Falling Edge Reset CNT 1110: Rising Edge Reset CNT 1111: High Level Reset CNT
	1979		
	1980		
	1981		
	1982	DM0_0 Configuration Register 4 MUX1 selection for LUT2	0: from LUT3 1: from matrix (DLY IN)
	1983	DM0_0 Configuration Register 4 MUX2 selection for DLY input	0: from matrix (DLY IN) 1: from LUT3
F8	1984	DM0_0 Configuration Register 5 IN0 of LUT3	REG_MATRIX_LUT3_IN0_SEL[5:0]
	1985		
	1986		
	1987		
	1988		
	1989		
	1990	DM0_0 Configuration Register 5 IN1 of LUT3	REG_MATRIX_LUT3_IN1_SEL[5:0]
	1991		
F9	1992		
	1993		
	1994		
	1995		

GreenPAK Programmable Mixed-Signal Matrix with Asynchronous State Machine and Dual Supply

Table 56: Register Map (Continued)

Address		Signal Function	Register Bit Definition
Byte	Register Bit		
F9	1996	DM0_0 Configuration Register 5 IN2 of LUT3	REG_MATRIX_LUT3_IN2_SEL[5:0]
	1997		
	1998		
	1999		
FA	2000	DM0_0 Configuration Register 5 DLY input from matrix	DM Delay input
	2001		
	2002		
	2003		
	2004		
	2005		
	2006		
FB	2008	DM0_0 Configuration Register 5 Data of LUT3	REG_VAL_LUT3[0]
	2009		REG_VAL_LUT3[1]
	2010		REG_VAL_LUT3[2]
	2011		REG_VAL_LUT3[3]
	2012		REG_VAL_LUT3[4]
	2013		REG_VAL_LUT3[5]
	2014		REG_VAL_LUT3[6]
	2015		REG_VAL_LUT3[7]
FC	2016	DM0_0 Configuration Register 5 Data of LUT2	REG_VAL_LUT2[0]
	2017		REG_VAL_LUT2[1]
	2018		REG_VAL_LUT2[2]
	2019		REG_VAL_LUT2[3]
	2020	DM0_0 Configuration Register 5 Clock source selection	Clock source sel[3:0] 0000: 25M; 0001: 25M/4; 0010: 2.048M 0011: 2.048M/8; 0100: 2.048M/64; 0101: 2.048M/512; 0110: 2.048K; 0111: 2.048K/8; 1000: 2.048K/64; 1001: 2.048K/512; 1010: 2.048K/4096 1011: 2.048K/32768; 1100: 2.048K/262144; 1101: CNT_END; 1110: External; 1111: External
	2021		
	2022		
	2023		

GreenPAK Programmable Mixed-Signal Matrix with Asynchronous State Machine and Dual Supply

Table 56: Register Map (Continued)

Address		Signal Function	Register Bit Definition
Byte	Register Bit		
FD	2024	DM0_0 Configuration Register 5 Data of Delay	Data[7:0]
	2025		
	2026		
	2027		
	2028		
	2029		
	2030		
	2031		
FE	2032	DM0_0 Configuration Register 5 DLY input initial selection	00: bypass the initial 01: initial 0 10: initial 1 11: initial 1
	2033		
	2034	DM0_0 Configuration Register 5 DLY/CNT Function selection	0000: Both Edge Delay 0001: Falling Edge Delay 0010: Rising Edge Delay 0011: Both Edge One Shot 0100: Falling Edge One Shot 0101: Rising Edge One Shot 0110: Both Edge Freq Detect 0111: Falling Edge Freq Detect 1000: Rising Edge Freq Detect 1001: Both Edge Detect 1010: Falling Edge Detect 1011: Rising Edge Detect 1100: Both Edge Reset CNT 1101: Falling Edge Reset CNT 1110: Rising Edge Reset CNT 1111: High Level Reset CNT
	2035		
	2036		
	2037		
2038	DM0_0 Configuration Register 5 MUX1 selection for LUT2	0: from LUT3 1: from matrix (DLY IN)	
2039	DM0_0 Configuration Register 5 MUX2 selection for DLY input	0: from matrix (DLY IN) 1: from LUT3	
FF	2040	Reserved	
	2041		
	2042		
	2043		
	2044		
	2045		
	2046		
	2047		
100	2048	DM0_1 Configuration Register 0 IN0 of LUT3	REG_MATRIX_LUT3_IN0_SEL[5:0]
	2049		
	2050		
	2051		
	2052		
	2053		

GreenPAK Programmable Mixed-Signal Matrix with Asynchronous State Machine and Dual Supply

Table 56: Register Map (Continued)

Address		Signal Function	Register Bit Definition
Byte	Register Bit		
100	2054		
	2055		
101	2056	DM0_1 Configuration Register 0 IN1 of LUT3	REG_MATRIX_LUT3_IN1_SEL[5:0]
	2057		
	2058		
	2059		
	2060		
102	2061	DM0_1 Configuration Register 0 IN2 of LUT3	REG_MATRIX_LUT3_IN2_SEL[5:0]
	2062		
	2063		
	2064		
102	2065	DM0_1 Configuration Register 0 DLY input from matrix	DM Delay input
	2066		
	2067		
	2068		
	2069		
103	2070	DM0_1 Configuration Register 0 Data of LUT3	
	2071		
	2072		
	2073		
	2074		
	2075		
	2076		
	2077		
104	2078	DM0_1 Configuration Register 0 Data of LUT2	REG_VAL_LUT3[0]
	2079		REG_VAL_LUT3[1]
	2080		REG_VAL_LUT3[2]
	2081		REG_VAL_LUT3[3]
	2082		REG_VAL_LUT3[4]
	2083		REG_VAL_LUT3[5]
	2084		REG_VAL_LUT3[6]
104	2085	DM0_1 Configuration Register 0 Data of LUT2	REG_VAL_LUT3[7]
	2086		REG_VAL_LUT2[0]
	2087		REG_VAL_LUT2[1]
	2088		REG_VAL_LUT2[2]
104	2089		REG_VAL_LUT2[3]
	2090		

GreenPAK Programmable Mixed-Signal Matrix with Asynchronous State Machine and Dual Supply

Table 56: Register Map (Continued)

Address		Signal Function	Register Bit Definition		
Byte	Register Bit				
104	2084	DM0_1 Configuration Register 0 Clock source selection	Clock source sel[3:0] 0000: 25M; 0001: 25M/4; 0010: 2.048M 0011: 2.048M/8; 0100: 2.048M/64; 0101: 2.048M/512; 0110: 2.048K; 0111: 2.048K/8; 1000: 2.048K/64; 1001: 2.048K/512; 1010: 2.048K/4096 1011: 2.048K/32768; 1100: 2.048K/262144; 1101: CNT_END; 1110: External; 1111: External		
	2085				
	2086				
	2087				
105	2088	DM0_1 Configuration Register 0 Data of Delay	Data[7:0]		
	2089				
	2090				
	2091				
	2092				
	2093				
	2094				
106	2096	DM0_1 Configuration Register 0 DLY input initial selection	00: bypass the initial 01: initial 0 10: initial 1 11: initial 1		
	2097				
	2098	DM0_1 Configuration Register 0 DLY/CNT Function selection	0000: Both Edge Delay 0001: Falling Edge Delay 0010: Rising Edge Delay 0011: Both Edge One Shot 0100: Falling Edge One Shot 0101: Rising Edge One Shot 0110: Both Edge Freq Detect 0111: Falling Edge Freq Detect 1000: Rising Edge Freq Detect 1001: Both Edge Detect 1010: Falling Edge Detect 1011: Rising Edge Detect 1100: Both Edge Reset CNT 1101: Falling Edge Reset CNT 1110: Rising Edge Reset CNT 1111: High Level Reset CNT		
	2099				
	2100				
	2101				
	2102			DM0_1 Configuration Register 0 MUX1 selection for LUT2	0: from LUT3 1: from matrix (DLY IN)
	2103			DM0_1 Configuration Register 0 MUX2 selection for DLY input	0: from matrix (DLY IN) 1: from LUT3

GreenPAK Programmable Mixed-Signal Matrix with Asynchronous State Machine and Dual Supply

Table 56: Register Map (Continued)

Address		Signal Function	Register Bit Definition
Byte	Register Bit		
107	2104	DM0_1 Configuration Register 1 IN0 of LUT3	REG_MATRIX_LUT3_IN0_SEL[5:0]
	2105		
	2106		
	2107		
	2108		
	2109		
	2110		
108	2111	DM0_1 Configuration Register 1 IN1 of LUT3	REG_MATRIX_LUT3_IN1_SEL[5:0]
	2112		
	2113		
	2114		
	2115		
	2116		
	2117		
109	2118	DM0_1 Configuration Register 1 IN2 of LUT3	REG_MATRIX_LUT3_IN2_SEL[5:0]
	2119		
	2120		
	2121		
	2122		
	2123		
	2124		
2125			
2126			
2127			
10A	2128	DM0_1 Configuration Register 1 Data of LUT3	REG_VAL_LUT3[0]
	2129		REG_VAL_LUT3[1]
	2130		REG_VAL_LUT3[2]
	2131		REG_VAL_LUT3[3]
	2132		REG_VAL_LUT3[4]
	2133		REG_VAL_LUT3[5]
	2134		REG_VAL_LUT3[6]
2135	REG_VAL_LUT3[7]		
10B	2136	DM0_1 Configuration Register 1 Data of LUT2	REG_VAL_LUT2[0]
	2137		REG_VAL_LUT2[1]
	2138		REG_VAL_LUT2[2]
	2139		REG_VAL_LUT2[3]

GreenPAK Programmable Mixed-Signal Matrix with Asynchronous State Machine and Dual Supply

Table 56: Register Map (Continued)

Address		Signal Function	Register Bit Definition
Byte	Register Bit		
10B	2140	DM0_1 Configuration Register 1 Clock source selection	Clock source sel[3:0] 0000: 25M; 0001: 25M/4; 0010: 2.048M 0011: 2.048M/8; 0100: 2.048M/64; 0101: 2.048M/512; 0110: 2.048K; 0111: 2.048K/8; 1000: 2.048K/64; 1001: 2.048K/512; 1010: 2.048K/4096 1011: 2.048K/32768; 1100: 2.048K/262144; 1101: CNT_END; 1110: External; 1111: External
	2141		
	2142		
	2143		
10C	2144	DM0_1 Configuration Register 1 Data of Delay	Data[7:0]
	2145		
	2146		
	2147		
	2148		
	2149		
	2150		
10D	2151		
	2152	DM0_1 Configuration Register 1 DLY input initial selection	00: bypass the initial 01: initial 0 10: initial 1 11: initial 1
	2153		
	2154	DM0_1 Configuration Register 1 DLY/CNT Function selection	0000: Both Edge Delay 0001: Falling Edge Delay 0010: Rising Edge Delay 0011: Both Edge One Shot 0100: Falling Edge One Shot 0101: Rising Edge One Shot 0110: Both Edge Freq Detect 0111: Falling Edge Freq Detect 1000: Rising Edge Freq Detect 1001: Both Edge Detect 1010: Falling Edge Detect 1011: Rising Edge Detect 1100: Both Edge Reset CNT 1101: Falling Edge Reset CNT 1110: Rising Edge Reset CNT 1111: High Level Reset CNT
	2155		
	2156		
	2157		
	2158		
2159	DM0_1 Configuration Register 1 MUX2 selection for DLY input	0: from matrix (DLY IN) 1: from LUT3	

GreenPAK Programmable Mixed-Signal Matrix with Asynchronous State Machine and Dual Supply

Table 56: Register Map (Continued)

Address		Signal Function	Register Bit Definition		
Byte	Register Bit				
10E	2160	DM0_1 Configuration Register 2 IN0 of LUT3	REG_MATRIX_LUT3_IN0_SEL[5:0]		
	2161				
	2162				
	2163				
	2164				
	2165				
	2166				
10F	2167	DM0_1 Configuration Register 2 IN1 of LUT3	REG_MATRIX_LUT3_IN1_SEL[5:0]		
	2168				
	2169				
	2170				
	2171				
	2172				
	2173				
110	2174	DM0_1 Configuration Register 2 IN2 of LUT3	REG_MATRIX_LUT3_IN2_SEL[5:0]		
	2175				
	2176				
	2177				
	2178				
	2179				
	2180			DM0_1 Configuration Register 2 DLY input from matrix	DM Delay input
2181					
2182					
2183					
111	2184	DM0_1 Configuration Register 2 Data of LUT3	REG_VAL_LUT3[0]		
	2185		REG_VAL_LUT3[1]		
	2186		REG_VAL_LUT3[2]		
	2187		REG_VAL_LUT3[3]		
	2188		REG_VAL_LUT3[4]		
	2189		REG_VAL_LUT3[5]		
	2190		REG_VAL_LUT3[6]		
112	2191	REG_VAL_LUT3[7]			
	2192	DM0_1 Configuration Register 2 Data of LUT2	REG_VAL_LUT2[0]		
	2193		REG_VAL_LUT2[1]		
	2194		REG_VAL_LUT2[2]		
	2195		REG_VAL_LUT2[3]		

GreenPAK Programmable Mixed-Signal Matrix with Asynchronous State Machine and Dual Supply

Table 56: Register Map (Continued)

Address		Signal Function	Register Bit Definition		
Byte	Register Bit				
112	2196	DM0_1 Configuration Register 2 Clock source selection	Clock source sel[3:0] 0000: 25M; 0001: 25M/4; 0010: 2.048M 0011: 2.048M/8; 0100: 2.048M/64; 0101: 2.048M/512; 0110: 2.048K; 0111: 2.048K/8; 1000: 2.048K/64; 1001: 2.048K/512; 1010: 2.048K/4096 1011: 2.048K/32768; 1100: 2.048K/262144; 1101: CNT_END; 1110: External; 1111: External		
	2197				
	2198				
	2199				
113	2200	DM0_1 Configuration Register 2 Data of Delay	Data[7:0]		
	2201				
	2202				
	2203				
	2204				
	2205				
	2206				
	2207				
114	2208	DM0_1 Configuration Register 2 DLY input initial selection	00: bypass the initial 01: initial 0 10: initial 1 11: initial 1		
	2209				
	2210	DM0_1 Configuration Register 2 DLY/CNT Function selection	0000: Both Edge Delay 0001: Falling Edge Delay 0010: Rising Edge Delay 0011: Both Edge One Shot 0100: Falling Edge One Shot 0101: Rising Edge One Shot 0110: Both Edge Freq Detect 0111: Falling Edge Freq Detect 1000: Rising Edge Freq Detect 1001: Both Edge Detect 1010: Falling Edge Detect 1011: Rising Edge Detect 1100: Both Edge Reset CNT 1101: Falling Edge Reset CNT 1110: Rising Edge Reset CNT 1111: High Level Reset CNT		
	2211				
	2212				
	2213				
	2214			DM0_1 Configuration Register 2 MUX1 selection for LUT2	0: from LUT3 1: from matrix (DLY IN)
	2215			DM0_1 Configuration Register 2 MUX2 selection for DLY input	0: from matrix (DLY IN) 1: from LUT3

GreenPAK Programmable Mixed-Signal Matrix with Asynchronous State Machine and Dual Supply

Table 56: Register Map (Continued)

Address		Signal Function	Register Bit Definition	
Byte	Register Bit			
115	2216	DM0_1 Configuration Register 3 IN0 of LUT3	REG_MATRIX_LUT3_IN0_SEL[5:0]	
	2217			
	2218			
	2219			
	2220			
	2221			
	2222			
116	2224	DM0_1 Configuration Register 3 IN1 of LUT3	REG_MATRIX_LUT3_IN1_SEL[5:0]	
	2225			
	2226			
	2227	DM0_1 Configuration Register 3 IN2 of LUT3	REG_MATRIX_LUT3_IN2_SEL[5:0]	
	2228			
	2229			
	2230			
117	2231	DM0_1 Configuration Register 3 DLY input from matrix	DM Delay input	
	2232			
	2233			
	2234			
	2235			
	2236			
	2237			
118	2238	DM0_1 Configuration Register 3 Data of LUT3	REG_VAL_LUT3[0]	
	2239			REG_VAL_LUT3[1]
	2240			REG_VAL_LUT3[2]
	2241			REG_VAL_LUT3[3]
	2242			REG_VAL_LUT3[4]
	2243			REG_VAL_LUT3[5]
	2244			REG_VAL_LUT3[6]
	2245			REG_VAL_LUT3[7]
119	2246	DM0_1 Configuration Register 3 Data of LUT2	REG_VAL_LUT2[0]	
	2247		REG_VAL_LUT2[1]	
	2248		REG_VAL_LUT2[2]	
	2249		REG_VAL_LUT2[3]	
2250				
2251				

GreenPAK Programmable Mixed-Signal Matrix with Asynchronous State Machine and Dual Supply

Table 56: Register Map (Continued)

Address		Signal Function	Register Bit Definition
Byte	Register Bit		
119	2252	DM0_1 Configuration Register 3 Clock source selection	Clock source sel[3:0] 0000: 25M; 0001: 25M/4; 0010: 2.048M 0011: 2.048M/8; 0100: 2.048M/64; 0101: 2.048M/512; 0110: 2.048K; 0111: 2.048K/8; 1000: 2.048K/64; 1001: 2.048K/512; 1010: 2.048K/4096 1011: 2.048K/32768; 1100: 2.048K/262144; 1101: CNT_END; 1110: External; 1111: External
	2253		
	2254		
	2255		
11A	2256	DM0_1 Configuration Register 3 Data of Delay	Data[7:0]
	2257		
	2258		
	2259		
	2260		
	2261		
	2262		
11B	2263	DM0_1 Configuration Register 3 DLY/CNT Function selection	00: bypass the initial 01: initial 0 10: initial 1 11: initial 1
	2264		
	2265		
	2266		
	2267		
	2268		
	2269		
	2270		
2271	DM0_1 Configuration Register 3 MUX2 selection for DLY input	0: from matrix (DLY IN) 1: from LUT3	

GreenPAK Programmable Mixed-Signal Matrix with Asynchronous State Machine and Dual Supply

Table 56: Register Map (Continued)

Address		Signal Function	Register Bit Definition
Byte	Register Bit		
11C	2272	DM0_1 Configuration Register 4 IN0 of LUT3	REG_MATRIX_LUT3_IN0_SEL[5:0]
	2273		
	2274		
	2275		
	2276		
	2277		
	2278		
11D	2279	DM0_1 Configuration Register 4 IN1 of LUT3	REG_MATRIX_LUT3_IN1_SEL[5:0]
	2280		
	2281		
	2282		
	2283		
	2284		
	2285		
11E	2286	DM0_1 Configuration Register 4 IN2 of LUT3	REG_MATRIX_LUT3_IN2_SEL[5:0]
	2287		
	2288		
	2289		
	2290		
	2291		
	2292		
2293			
2294			
2295			
2296			
11F	2297	DM0_1 Configuration Register 4 Data of LUT3	REG_VAL_LUT3[0]
	2298		REG_VAL_LUT3[1]
	2299		REG_VAL_LUT3[2]
	2300		REG_VAL_LUT3[3]
	2301		REG_VAL_LUT3[4]
	2302		REG_VAL_LUT3[5]
	2303		REG_VAL_LUT3[6]
	2304		REG_VAL_LUT3[7]
120	2305	DM0_1 Configuration Register 4 Data of LUT2	REG_VAL_LUT2[0]
	2306		REG_VAL_LUT2[1]
	2307		REG_VAL_LUT2[2]
	2308		REG_VAL_LUT2[3]

GreenPAK Programmable Mixed-Signal Matrix with Asynchronous State Machine and Dual Supply

Table 56: Register Map (Continued)

Address		Signal Function	Register Bit Definition
Byte	Register Bit		
120	2308	DM0_1 Configuration Register 4 Clock source selection	Clock source sel[3:0] 0000: 25M; 0001: 25M/4; 0010: 2.048M 0011: 2.048M/8; 0100: 2.048M/64; 0101: 2.048M/512; 0110: 2.048K; 0111: 2.048K/8; 1000: 2.048K/64; 1001: 2.048K/512; 1010: 2.048K/4096 1011: 2.048K/32768; 1100: 2.048K/262144; 1101: CNT_END; 1110: External; 1111: External
	2309		
	2310		
	2311		
121	2312	DM0_1 Configuration Register 4 Data of Delay	Data[7:0]
	2313		
	2314		
	2315		
	2316		
	2317		
	2318		
	2319		
122	2320	DM0_1 Configuration Register 4 DLY input initial selection	00: bypass the initial 01: initial 0 10: initial 1 11: initial 1
	2321		
	2322	DM0_1 Configuration Register 4 DLY/CNT Function selection	0000: Both Edge Delay 0001: Falling Edge Delay 0010: Rising Edge Delay 0011: Both Edge One Shot 0100: Falling Edge One Shot 0101: Rising Edge One Shot 0110: Both Edge Freq Detect 0111: Falling Edge Freq Detect 1000: Rising Edge Freq Detect 1001: Both Edge Detect 1010: Falling Edge Detect 1011: Rising Edge Detect 1100: Both Edge Reset CNT 1101: Falling Edge Reset CNT 1110: Rising Edge Reset CNT 1111: High Level Reset CNT
	2323		
	2324		
	2325		
	2326		
	2327	DM0_1 Configuration Register 4 MUX2 selection for DLY input	0: from matrix (DLY IN) 1: from LUT3

GreenPAK Programmable Mixed-Signal Matrix with Asynchronous State Machine and Dual Supply
Table 56: Register Map (Continued)

Address		Signal Function	Register Bit Definition
Byte	Register Bit		
123	2328	DM0_1 Configuration Register 5 IN0 of LUT3	REG_MATRIX_LUT3_IN0_SEL[5:0]
	2329		
	2330		
	2331		
	2332		
	2333		
	2334		
124	2335	DM0_1 Configuration Register 5 IN1 of LUT3	REG_MATRIX_LUT3_IN1_SEL[5:0]
	2336		
	2337		
	2338		
	2339		
	2340		
	2341		
125	2342	DM0_1 Configuration Register 5 IN2 of LUT3	REG_MATRIX_LUT3_IN2_SEL[5:0]
	2343		
	2344		
	2345		
	2346		
	2347		
	2348		
126	2349	DM0_1 Configuration Register 5 DLY input from matrix	DM Delay input
	2350		
	2351		
	2352		
	2353		
	2354		
	2355		
	2356		
2357			
126	2358	DM0_1 Configuration Register 5 Data of LUT3	REG_VAL_LUT3[0]
	2359		
	2352		
	2353		
	2354		
	2355		
	2356		
2357			
2358			
2359			

GreenPAK Programmable Mixed-Signal Matrix with Asynchronous State Machine and Dual Supply

Table 56: Register Map (Continued)

Address		Signal Function	Register Bit Definition
Byte	Register Bit		
127	2360	DM0_1 Configuration Register 5 Data of LUT2	REG_VAL_LUT2[0]
	2361		REG_VAL_LUT2[1]
	2362		REG_VAL_LUT2[2]
	2363		REG_VAL_LUT2[3]
	2364	DM0_1 Configuration Register 5 Clock source selection	Clock source sel[3:0] 0000: 25M; 0001: 25M/4; 0010: 2.048M 0011: 2.048M/8; 0100: 2.048M/64; 0101: 2.048M/512; 0110: 2.048K; 0111: 2.048K/8; 1000: 2.048K/64; 1001: 2.048K/512; 1010: 2.048K/4096 1011: 2.048K/32768; 1100: 2.048K/262144; 1101: CNT_END; 1110: External; 1111: External
	2365		
	2366		
	2367		
128	2368	DM0_1 Configuration Register 5 Data of Delay	Data[7:0]
	2369		
	2370		
	2371		
	2372		
	2373		
	2374		
	2375		
129	2376	DM0_1 Configuration Register 5 DLY input initial selection	00: bypass the initial 01: initial 0 10: initial 1 11: initial 1
	2377		
	2378	DM0_1 Configuration Register 5 DLY/CNT Function selection	0000: Both Edge Delay 0001: Falling Edge Delay 0010: Rising Edge Delay 0011: Both Edge One Shot 0100: Falling Edge One Shot 0101: Rising Edge One Shot 0110: Both Edge Freq Detect 0111: Falling Edge Freq Detect 1000: Rising Edge Freq Detect 1001: Both Edge Detect 1010: Falling Edge Detect 1011: Rising Edge Detect 1100: Both Edge Reset CNT 1101: Falling Edge Reset CNT 1110: Rising Edge Reset CNT 1111: High Level Reset CNT
	2379		
	2380		
	2381		
	2382	DM0_1 Configuration Register 5 MUX1 selection for LUT2	0: from LUT3 1: from matrix (DLY IN)

GreenPAK Programmable Mixed-Signal Matrix with Asynchronous State Machine and Dual Supply

Table 56: Register Map (Continued)

Address		Signal Function	Register Bit Definition
Byte	Register Bit		
129	2383	DM0_1 Configuration Register 5 MUX2 selection for DLY input	0: from matrix (DLY IN) 1: from LUT3
12A	2384	DM1_0 Configuration Register 0 IN0 of LUT3	REG_MATRIX_LUT3_IN0_SEL[5:0]
	2385		
	2386		
	2387		
	2388		
	2389		
12B	2390	DM1_0 Configuration Register 0 IN1 of LUT3	REG_MATRIX_LUT3_IN1_SEL[5:0]
	2391		
	2392		
	2393		
	2394		
	2395		
12C	2396	DM1_0 Configuration Register 0 IN2 of LUT3	REG_MATRIX_LUT3_IN2_SEL[5:0]
	2397		
	2398		
	2399		
	2400		
	2401		
12D	2402	DM1_0 Configuration Register 0 DLY input from matrix	DM Delay input
	2403		
	2404		
	2405		
	2406		
	2407		
12E	2408	DM1_0 Configuration Register 0 Data of LUT3	REG_VAL_LUT3[0]
	2409		REG_VAL_LUT3[1]
	2410		REG_VAL_LUT3[2]
	2411		REG_VAL_LUT3[3]
	2412		REG_VAL_LUT3[4]
	2413		REG_VAL_LUT3[5]
	2414		REG_VAL_LUT3[6]
	2415		REG_VAL_LUT3[7]
12E	2416	DM1_0 Configuration Register 0 Data of LUT2	REG_VAL_LUT2[0]
	2417		REG_VAL_LUT2[1]
	2418		REG_VAL_LUT2[2]
	2419		REG_VAL_LUT2[3]

GreenPAK Programmable Mixed-Signal Matrix with Asynchronous State Machine and Dual Supply

Table 56: Register Map (Continued)

Address		Signal Function	Register Bit Definition		
Byte	Register Bit				
12E	2420	DM1_0 Configuration Register 0 Clock source selection	Clock source sel[3:0] 0000: 25M; 0001: 25M/4; 0010: 2.048M 0011: 2.048M/8; 0100: 2.048M/64; 0101: 2.048M/512; 0110: 2.048K; 0111: 2.048K/8; 1000: 2.048K/64; 1001: 2.048K/512; 1010: 2.048K/4096 1011: 2.048K/32768; 1100: 2.048K/262144; 1101: CNT_END; 1110: External; 1111: External		
	2421				
	2422				
	2423				
12F	2424	DM1_0 Configuration Register 0 Data of Delay	Data[7:0]		
	2425				
	2426				
	2427				
	2428				
	2429				
	2430				
130	2431	DM1_0 Configuration Register 0 DLY/CNT Function selection	00: bypass the initial 01: initial 0 10: initial 1 11: initial 1		
	2432				
	2433				
	2434				
	2435				
	2436				
	2437				
	2438			DM1_0 Configuration Register 0 MUX1 selection for LUT2	0: from LUT3 1: from matrix (DLY IN)
	2439			DM1_0 Configuration Register 0 MUX2 selection for DLY input	0: from matrix (DLY IN) 1: from LUT3

GreenPAK Programmable Mixed-Signal Matrix with Asynchronous State Machine and Dual Supply

Table 56: Register Map (Continued)

Address		Signal Function	Register Bit Definition		
Byte	Register Bit				
131	2440	DM1_0 Configuration Register 1 IN0 of LUT3	REG_MATRIX_LUT3_IN0_SEL[5:0]		
	2441				
	2442				
	2443				
	2444				
	2445				
	2446				
132	2447	DM1_0 Configuration Register 1 IN1 of LUT3	REG_MATRIX_LUT3_IN1_SEL[5:0]		
	2448				
	2449				
	2450				
	2451				
	2452				
	2453				
133	2454	DM1_0 Configuration Register 1 IN2 of LUT3	REG_MATRIX_LUT3_IN2_SEL[5:0]		
	2455				
	2456				
	2457				
	2458				
	2459				
	2460			DM1_0 Configuration Register 1 DLY input from matrix	DM Delay input
2461					
2462					
2463					
134	2464	DM1_0 Configuration Register 1 Data of LUT3	REG_VAL_LUT3[0]		
	2465		REG_VAL_LUT3[1]		
	2466		REG_VAL_LUT3[2]		
	2467		REG_VAL_LUT3[3]		
	2468		REG_VAL_LUT3[4]		
	2469		REG_VAL_LUT3[5]		
	2470		REG_VAL_LUT3[6]		
	2471		REG_VAL_LUT3[7]		
135	2472	DM1_0 Configuration Register 1 Data of LUT2	REG_VAL_LUT2[0]		
	2473		REG_VAL_LUT2[1]		
	2474		REG_VAL_LUT2[2]		
	2475		REG_VAL_LUT2[3]		

GreenPAK Programmable Mixed-Signal Matrix with Asynchronous State Machine and Dual Supply

Table 56: Register Map (Continued)

Address		Signal Function	Register Bit Definition
Byte	Register Bit		
135	2476	DM1_0 Configuration Register 1 Clock source selection	Clock source sel[3:0] 0000: 25M; 0001: 25M/4; 0010: 2.048M 0011: 2.048M/8; 0100: 2.048M/64; 0101: 2.048M/512; 0110: 2.048K; 0111: 2.048K/8; 1000: 2.048K/64; 1001: 2.048K/512; 1010: 2.048K/4096 1011: 2.048K/32768; 1100: 2.048K/262144; 1101: CNT_END; 1110: External; 1111: External
	2477		
	2478		
	2479		
136	2480	DM1_0 Configuration Register 1 Data of Delay	Data[7:0]
	2481		
	2482		
	2483		
	2484		
	2485		
	2486		
137	2487	DM1_0 Configuration Register 1 DLY/CNT Function selection	00: bypass the initial 01: initial 0 10: initial 1 11: initial 1
	2488		
	2489		
	2490		
	2491		
	2492		
	2493		
	2494		
2495	DM1_0 Configuration Register 1 MUX2 selection for DLY input	0: from matrix (DLY IN) 1: from LUT3	

GreenPAK Programmable Mixed-Signal Matrix with Asynchronous State Machine and Dual Supply

Table 56: Register Map (Continued)

Address		Signal Function	Register Bit Definition	
Byte	Register Bit			
138	2496	DM1_0 Configuration Register 2 IN0 of LUT3	REG_MATRIX_LUT3_IN0_SEL[5:0]	
	2497			
	2498			
	2499			
	2500			
	2501			
	2502			
139	2503	DM1_0 Configuration Register 2 IN1 of LUT3	REG_MATRIX_LUT3_IN1_SEL[5:0]	
	2504			
	2505			
	2506			
	2507			
	2508			
	2509			
13A	2510	DM1_0 Configuration Register 2 IN2 of LUT3	REG_MATRIX_LUT3_IN2_SEL[5:0]	
	2511			
	2512			
	2513			
	2514			
	2515			
	2516			
13B	2517	DM1_0 Configuration Register 2 DLY input from matrix	DM Delay input	
	2518			
	2519			
	2520			REG_VAL_LUT3[0]
	2521			REG_VAL_LUT3[1]
	2522			REG_VAL_LUT3[2]
	2523			REG_VAL_LUT3[3]
2524	REG_VAL_LUT3[4]			
13C	2525	DM1_0 Configuration Register 2 Data of LUT3	REG_VAL_LUT3[5]	
	2526		REG_VAL_LUT3[6]	
	2527		REG_VAL_LUT3[7]	
	2528		REG_VAL_LUT2[0]	
	2529		REG_VAL_LUT2[1]	
	2530		REG_VAL_LUT2[2]	
	2531		REG_VAL_LUT2[3]	

GreenPAK Programmable Mixed-Signal Matrix with Asynchronous State Machine and Dual Supply

Table 56: Register Map (Continued)

Address		Signal Function	Register Bit Definition
Byte	Register Bit		
13C	2532	DM1_0 Configuration Register 2 Clock source selection	Clock source sel[3:0] 0000: 25M; 0001: 25M/4; 0010: 2.048M 0011: 2.048M/8; 0100: 2.048M/64; 0101: 2.048M/512; 0110: 2.048K; 0111: 2.048K/8; 1000: 2.048K/64; 1001: 2.048K/512; 1010: 2.048K/4096 1011: 2.048K/32768; 1100: 2.048K/262144; 1101: CNT_END; 1110: External; 1111: External
	2533		
	2534		
	2535		
13D	2536	DM1_0 Configuration Register 2 Data of Delay	Data[7:0]
	2537		
	2538		
	2539		
	2540		
	2541		
	2542		
13E	2543	DM1_0 Configuration Register 2 DLY/CNT Function selection	00: bypass the initial 01: initial 0 10: initial 1 11: initial 1
	2544		
	2545		
	2546		
	2547		
	2548		
	2549		
2550	DM1_0 Configuration Register 2 MUX1 selection for LUT2	0: from LUT3 1: from matrix (DLY IN)	
2551	DM1_0 Configuration Register 2 MUX2 selection for DLY input	0: from matrix (DLY IN) 1: from LUT3	

GreenPAK Programmable Mixed-Signal Matrix with Asynchronous State Machine and Dual Supply

Table 56: Register Map (Continued)

Address		Signal Function	Register Bit Definition
Byte	Register Bit		
13F	2552	DM1_0 Configuration Register 3 IN0 of LUT3	REG_MATRIX_LUT3_IN0_SEL[5:0]
	2553		
	2554		
	2555		
	2556		
	2557		
	2558		
140	2559	DM1_0 Configuration Register 3 IN1 of LUT3	REG_MATRIX_LUT3_IN1_SEL[5:0]
	2560		
	2561		
	2562		
	2563		
	2564		
	2565		
141	2566	DM1_0 Configuration Register 3 IN2 of LUT3	REG_MATRIX_LUT3_IN2_SEL[5:0]
	2567		
	2568		
	2569		
	2570		
	2571		
	2572		
142	2573	DM1_0 Configuration Register 3 DLY input from matrix	DM Delay input
	2574		
	2575		
	2576		
	2577		
	2578		
	2579		
143	2580	DM1_0 Configuration Register 3 Data of LUT3	REG_VAL_LUT3[0]
	2581		REG_VAL_LUT3[1]
	2582		REG_VAL_LUT3[2]
	2583		REG_VAL_LUT3[3]
	2584		REG_VAL_LUT3[4]
	2585		REG_VAL_LUT3[5]
	2586		REG_VAL_LUT3[6]
143	2587	DM1_0 Configuration Register 3 Data of LUT2	REG_VAL_LUT3[7]
	2584		REG_VAL_LUT2[0]
	2585		REG_VAL_LUT2[1]
	2586		REG_VAL_LUT2[2]
	2587		REG_VAL_LUT2[3]

GreenPAK Programmable Mixed-Signal Matrix with Asynchronous State Machine and Dual Supply

Table 56: Register Map (Continued)

Address		Signal Function	Register Bit Definition		
Byte	Register Bit				
143	2588	DM1_0 Configuration Register 3 Clock source selection	Clock source sel[3:0] 0000: 25M; 0001: 25M/4; 0010: 2.048M 0011: 2.048M/8; 0100: 2.048M/64; 0101: 2.048M/512; 0110: 2.048K; 0111: 2.048K/8; 1000: 2.048K/64; 1001: 2.048K/512; 1010: 2.048K/4096 1011: 2.048K/32768; 1100: 2.048K/262144; 1101: CNT_END; 1110: External; 1111: External		
	2589				
	2590				
	2591				
144	2592	DM1_0 Configuration Register 3 Data of Delay	Data[7:0]		
	2593				
	2594				
	2595				
	2596				
	2597				
	2598				
	2599				
145	2600	DM1_0 Configuration Register 3 DLY input initial selection	00: bypass the initial 01: initial 0 10: initial 1 11: initial 1		
	2601				
	2602	DM1_0 Configuration Register 3 DLY/CNT Function selection	0000: Both Edge Delay 0001: Falling Edge Delay 0010: Rising Edge Delay 0011: Both Edge One Shot 0100: Falling Edge One Shot 0101: Rising Edge One Shot 0110: Both Edge Freq Detect 0111: Falling Edge Freq Detect 1000: Rising Edge Freq Detect 1001: Both Edge Detect 1010: Falling Edge Detect 1011: Rising Edge Detect 1100: Both Edge Reset CNT 1101: Falling Edge Reset CNT 1110: Rising Edge Reset CNT 1111: High Level Reset CNT		
	2603				
	2604				
	2605				
	2606			DM1_0 Configuration Register 3 MUX1 selection for LUT2	0: from LUT3 1: from matrix (DLY IN)
	2607			DM1_0 Configuration Register 3 MUX2 selection for DLY input	0: from matrix (DLY IN) 1: from LUT3

GreenPAK Programmable Mixed-Signal Matrix with Asynchronous State Machine and Dual Supply

Table 56: Register Map (Continued)

Address		Signal Function	Register Bit Definition
Byte	Register Bit		
146	2608	DM1_0 Configuration Register 4 IN0 of LUT3	REG_MATRIX_LUT3_IN0_SEL[5:0]
	2609		
	2610		
	2611		
	2612		
	2613		
	2614		
147	2615	DM1_0 Configuration Register 4 IN1 of LUT3	REG_MATRIX_LUT3_IN1_SEL[5:0]
	2616		
	2617		
	2618		
	2619		
	2620		
	2621		
148	2622	DM1_0 Configuration Register 4 IN2 of LUT3	REG_MATRIX_LUT3_IN2_SEL[5:0]
	2623		
	2624		
	2625		
	2626		
	2627		
	2628		
2629			
2630			
2631			
2632			
149	2633	DM1_0 Configuration Register 4 Data of LUT3	REG_VAL_LUT3[0]
	2634		REG_VAL_LUT3[1]
	2635		REG_VAL_LUT3[2]
	2636		REG_VAL_LUT3[3]
	2637		REG_VAL_LUT3[4]
	2638		REG_VAL_LUT3[5]
	2639		REG_VAL_LUT3[6]
14A	2640	DM1_0 Configuration Register 4 Data of LUT2	REG_VAL_LUT3[7]
	2641		REG_VAL_LUT2[0]
	2642		REG_VAL_LUT2[1]
	2643		REG_VAL_LUT2[2]

GreenPAK Programmable Mixed-Signal Matrix with Asynchronous State Machine and Dual Supply

Table 56: Register Map (Continued)

Address		Signal Function	Register Bit Definition
Byte	Register Bit		
14A	2644	DM1_0 Configuration Register 4 Clock source selection	Clock source sel[3:0] 0000: 25M; 0001: 25M/4; 0010: 2.048M 0011: 2.048M/8; 0100: 2.048M/64; 0101: 2.048M/512; 0110: 2.048K; 0111: 2.048K/8; 1000: 2.048K/64; 1001: 2.048K/512; 1010: 2.048K/4096 1011: 2.048K/32768; 1100: 2.048K/262144; 1101: CNT_END; 1110: External; 1111: External
	2645		
	2646		
	2647		
14B	2648	DM1_0 Configuration Register 4 Data of Delay	Data[7:0]
	2649		
	2650		
	2651		
	2652		
	2653		
	2654		
14C	2655	DM1_0 Configuration Register 4 DLY/CNT Function selection	00: bypass the initial 01: initial 0 10: initial 1 11: initial 1
	2656		
	2657		
	2658		
	2659		
	2660		
	2661		
	2662		
2663	DM1_0 Configuration Register 4 MUX2 selection for DLY input	0: from matrix (DLY IN) 1: from LUT3	

GreenPAK Programmable Mixed-Signal Matrix with Asynchronous State Machine and Dual Supply

Table 56: Register Map (Continued)

Address		Signal Function	Register Bit Definition		
Byte	Register Bit				
14D	2664	DM1_0 Configuration Register 5 IN0 of LUT3	REG_MATRIX_LUT3_IN0_SEL[5:0]		
	2665				
	2666				
	2667				
	2668				
	2669				
	2670				
14E	2671	DM1_0 Configuration Register 5 IN1 of LUT3	REG_MATRIX_LUT3_IN1_SEL[5:0]		
	2672				
	2673				
	2674				
	2675				
	2676				
	2677				
14F	2678	DM1_0 Configuration Register 5 IN2 of LUT3	REG_MATRIX_LUT3_IN2_SEL[5:0]		
	2679				
	2680				
	2681				
	2682				
	2683				
	2684			DM1_0 Configuration Register 5 DLY input from matrix	DM Delay input
2685					
2686					
2687					
150	2688	DM1_0 Configuration Register 5 Data of LUT3	REG_VAL_LUT3[0]		
	2689		REG_VAL_LUT3[1]		
	2690		REG_VAL_LUT3[2]		
	2691		REG_VAL_LUT3[3]		
	2692		REG_VAL_LUT3[4]		
	2693		REG_VAL_LUT3[5]		
	2694		REG_VAL_LUT3[6]		
151	2695	REG_VAL_LUT3[7]			
	2696	DM1_0 Configuration Register 5 Data of LUT2	REG_VAL_LUT2[0]		
	2697		REG_VAL_LUT2[1]		
	2698		REG_VAL_LUT2[2]		
	2699		REG_VAL_LUT2[3]		

GreenPAK Programmable Mixed-Signal Matrix with Asynchronous State Machine and Dual Supply

Table 56: Register Map (Continued)

Address		Signal Function	Register Bit Definition		
Byte	Register Bit				
151	2700	DM1_0 Configuration Register 5 Clock source selection	Clock source sel[3:0] 0000: 25M; 0001: 25M/4; 0010: 2.048M 0011: 2.048M/8; 0100: 2.048M/64; 0101: 2.048M/512; 0110: 2.048K; 0111: 2.048K/8; 1000: 2.048K/64; 1001: 2.048K/512; 1010: 2.048K/4096 1011: 2.048K/32768; 1100: 2.048K/262144; 1101: CNT_END; 1110: External; 1111: External		
	2701				
	2702				
	2703				
152	2704	DM1_0 Configuration Register 5 Data of Delay	Data[7:0]		
	2705				
	2706				
	2707				
	2708				
	2709				
	2710				
	2711				
153	2712	DM1_0 Configuration Register 5 DLY input initial selection	00: bypass the initial 01: initial 0 10: initial 1 11: initial 1		
	2713				
	2714	DM1_0 Configuration Register 5 DLY/CNT Function selection	0000: Both Edge Delay 0001: Falling Edge Delay 0010: Rising Edge Delay 0011: Both Edge One Shot 0100: Falling Edge One Shot 0101: Rising Edge One Shot 0110: Both Edge Freq Detect 0111: Falling Edge Freq Detect 1000: Rising Edge Freq Detect 1001: Both Edge Detect 1010: Falling Edge Detect 1011: Rising Edge Detect 1100: Both Edge Reset CNT 1101: Falling Edge Reset CNT 1110: Rising Edge Reset CNT 1111: High Level Reset CNT		
	2715				
	2716				
	2717				
	2718			DM1_0 Configuration Register 5 MUX1 selection for LUT2	0: from LUT3 1: from matrix (DLY IN)
	2719			DM1_0 Configuration Register 5 MUX2 selection for DLY input	0: from matrix (DLY IN) 1: from LUT3

GreenPAK Programmable Mixed-Signal Matrix with Asynchronous State Machine and Dual Supply

Table 56: Register Map (Continued)

Address		Signal Function	Register Bit Definition		
Byte	Register Bit				
154	2720	DM1_1 Configuration Register 0 IN0 of LUT3	REG_MATRIX_LUT3_IN0_SEL[5:0]		
	2721				
	2722				
	2723				
	2724				
	2725				
	2726				
155	2727	DM1_1 Configuration Register 0 IN1 of LUT3	REG_MATRIX_LUT3_IN1_SEL[5:0]		
	2728				
	2729				
	2730				
	2731				
	2732				
	2733				
156	2734	DM1_1 Configuration Register 0 IN2 of LUT3	REG_MATRIX_LUT3_IN2_SEL[5:0]		
	2735				
	2736				
	2737				
	2738				
	2739				
	2740			DM1_1 Configuration Register 0 DLY input from matrix	DM Delay input
2741					
2742					
2743					
157	2744	DM1_1 Configuration Register 0 Data of LUT3	REG_VAL_LUT3[0]		
	2745		REG_VAL_LUT3[1]		
	2746		REG_VAL_LUT3[2]		
	2747		REG_VAL_LUT3[3]		
	2748		REG_VAL_LUT3[4]		
	2749		REG_VAL_LUT3[5]		
	2750		REG_VAL_LUT3[6]		
2751	REG_VAL_LUT3[7]				
158	2752	DM1_1 Configuration Register 0 Data of LUT2	REG_VAL_LUT2[0]		
	2753		REG_VAL_LUT2[1]		
	2754		REG_VAL_LUT2[2]		
	2755		REG_VAL_LUT2[3]		

GreenPAK Programmable Mixed-Signal Matrix with Asynchronous State Machine and Dual Supply

Table 56: Register Map (Continued)

Address		Signal Function	Register Bit Definition		
Byte	Register Bit				
158	2756	DM1_1 Configuration Register 0 Clock source selection	Clock source sel[3:0] 0000: 25M; 0001: 25M/4; 0010: 2.048M 0011: 2.048M/8; 0100: 2.048M/64; 0101: 2.048M/512; 0110: 2.048K; 0111: 2.048K/8; 1000: 2.048K/64; 1001: 2.048K/512; 1010: 2.048K/4096 1011: 2.048K/32768; 1100: 2.048K/262144; 1101: CNT_END; 1110: External; 1111: External		
	2757				
	2758				
	2759				
159	2760	DM1_1 Configuration Register 0 Data of Delay	Data[7:0]		
	2761				
	2762				
	2763				
	2764				
	2765				
	2766				
	2767				
15A	2768	DM1_1 Configuration Register 0 DLY input initial selection	00: bypass the initial 01: initial 0 10: initial 1 11: initial 1		
	2769				
	2770	DM1_1 Configuration Register 0 DLY/CNT Function selection	0000: Both Edge Delay 0001: Falling Edge Delay 0010: Rising Edge Delay 0011: Both Edge One Shot 0100: Falling Edge One Shot 0101: Rising Edge One Shot 0110: Both Edge Freq Detect 0111: Falling Edge Freq Detect 1000: Rising Edge Freq Detect 1001: Both Edge Detect 1010: Falling Edge Detect 1011: Rising Edge Detect 1100: Both Edge Reset CNT 1101: Falling Edge Reset CNT 1110: Rising Edge Reset CNT 1111: High Level Reset CNT		
	2771				
	2772				
	2773				
	2774			DM1_1 Configuration Register 0 MUX1 selection for LUT2	0: from LUT3 1: from matrix (DLY IN)
	2775			DM1_1 Configuration Register 0 MUX2 selection for DLY input	0: from matrix (DLY IN) 1: from LUT3

GreenPAK Programmable Mixed-Signal Matrix with Asynchronous State Machine and Dual Supply

Table 56: Register Map (Continued)

Address		Signal Function	Register Bit Definition		
Byte	Register Bit				
15B	2776	DM1_1 Configuration Register 1 IN0 of LUT3	REG_MATRIX_LUT3_IN0_SEL[5:0]		
	2777				
	2778				
	2779				
	2780				
	2781				
	2782				
15C	2783	DM1_1 Configuration Register 1 IN1 of LUT3	REG_MATRIX_LUT3_IN1_SEL[5:0]		
	2784				
	2785				
	2786				
	2787				
	2788				
	2789				
15D	2790	DM1_1 Configuration Register 1 IN2 of LUT3	REG_MATRIX_LUT3_IN2_SEL[5:0]		
	2791				
	2792				
	2793				
	2794				
	2795				
	2796			DM1_1 Configuration Register 1 DLY input from matrix	DM Delay input
2797					
2798					
2799					
15E	2800	DM1_1 Configuration Register 1 Data of LUT3	REG_VAL_LUT3[0]		
	2801		REG_VAL_LUT3[1]		
	2802		REG_VAL_LUT3[2]		
	2803		REG_VAL_LUT3[3]		
	2804		REG_VAL_LUT3[4]		
	2805		REG_VAL_LUT3[5]		
	2806		REG_VAL_LUT3[6]		
	2807		REG_VAL_LUT3[7]		
15F	2808	DM1_1 Configuration Register 1 Data of LUT2	REG_VAL_LUT2[0]		
	2809		REG_VAL_LUT2[1]		
	2810		REG_VAL_LUT2[2]		
	2811		REG_VAL_LUT2[3]		

GreenPAK Programmable Mixed-Signal Matrix with Asynchronous State Machine and Dual Supply

Table 56: Register Map (Continued)

Address		Signal Function	Register Bit Definition
Byte	Register Bit		
15F	2812	DM1_1 Configuration Register 1 Clock source selection	Clock source sel[3:0] 0000: 25M; 0001: 25M/4; 0010: 2.048M 0011: 2.048M/8; 0100: 2.048M/64; 0101: 2.048M/512; 0110: 2.048K; 0111: 2.048K/8; 1000: 2.048K/64; 1001: 2.048K/512; 1010: 2.048K/4096 1011: 2.048K/32768; 1100: 2.048K/262144; 1101: CNT_END; 1110: External; 1111: External
	2813		
	2814		
	2815		
160	2816	DM1_1 Configuration Register 1 Data of Delay	Data[7:0]
	2817		
	2818		
	2819		
	2820		
	2821		
	2822		
161	2823	DM1_1 Configuration Register 1 DLY/CNT Function selection	00: bypass the initial 01: initial 0 10: initial 1 11: initial 1
	2824		
	2825		
	2826		
	2827		
	2828		
	2829		
2830	DM1_1 Configuration Register 1 MUX1 selection for LUT2	0: from LUT3 1: from matrix (DLY IN)	
2831	DM1_1 Configuration Register 1 MUX2 selection for DLY input	0: from matrix (DLY IN) 1: from LUT3	

GreenPAK Programmable Mixed-Signal Matrix with Asynchronous State Machine and Dual Supply

Table 56: Register Map (Continued)

Address		Signal Function	Register Bit Definition
Byte	Register Bit		
162	2832	DM1_1 Configuration Register 2 IN0 of LUT3	REG_MATRIX_LUT3_IN0_SEL[5:0]
	2833		
	2834		
	2835		
	2836		
	2837		
	2838		
163	2839	DM1_1 Configuration Register 2 IN1 of LUT3	REG_MATRIX_LUT3_IN1_SEL[5:0]
	2840		
	2841		
	2842		
	2843		
	2844		
	2845		
164	2846	DM1_1 Configuration Register 2 IN2 of LUT3	REG_MATRIX_LUT3_IN2_SEL[5:0]
	2847		
	2848		
	2849		
	2850		
	2851		
	2852		
2853			
2854			
2855			
2856			
165	2857	DM1_1 Configuration Register 2 Data of LUT3	REG_VAL_LUT3[0]
	2858		REG_VAL_LUT3[1]
	2859		REG_VAL_LUT3[2]
	2860		REG_VAL_LUT3[3]
	2861		REG_VAL_LUT3[4]
	2862		REG_VAL_LUT3[5]
	2863		REG_VAL_LUT3[6]
166	2864	DM1_1 Configuration Register 2 Data of LUT2	REG_VAL_LUT3[7]
	2865		REG_VAL_LUT2[0]
	2866		REG_VAL_LUT2[1]
	2867		REG_VAL_LUT2[2]

GreenPAK Programmable Mixed-Signal Matrix with Asynchronous State Machine and Dual Supply

Table 56: Register Map (Continued)

Address		Signal Function	Register Bit Definition		
Byte	Register Bit				
166	2868	DM1_1 Configuration Register 2 Clock source selection	Clock source sel[3:0] 0000: 25M; 0001: 25M/4; 0010: 2.048M 0011: 2.048M/8; 0100: 2.048M/64; 0101: 2.048M/512; 0110: 2.048K; 0111: 2.048K/8; 1000: 2.048K/64; 1001: 2.048K/512; 1010: 2.048K/4096 1011: 2.048K/32768; 1100: 2.048K/262144; 1101: CNT_END; 1110: External; 1111: External		
	2869				
	2870				
	2871				
167	2872	DM1_1 Configuration Register 2 Data of Delay	Data[7:0]		
	2873				
	2874				
	2875				
	2876				
	2877				
	2878				
	2879				
168	2880	DM1_1 Configuration Register 2 DLY input initial selection	00: bypass the initial 01: initial 0 10: initial 1 11: initial 1		
	2881				
	2882	DM1_1 Configuration Register 2 DLY/CNT Function selection	0000: Both Edge Delay 0001: Falling Edge Delay 0010: Rising Edge Delay 0011: Both Edge One Shot 0100: Falling Edge One Shot 0101: Rising Edge One Shot 0110: Both Edge Freq Detect 0111: Falling Edge Freq Detect 1000: Rising Edge Freq Detect 1001: Both Edge Detect 1010: Falling Edge Detect 1011: Rising Edge Detect 1100: Both Edge Reset CNT 1101: Falling Edge Reset CNT 1110: Rising Edge Reset CNT 1111: High Level Reset CNT		
	2883				
	2884				
	2885				
	2886			DM1_1 Configuration Register 2 MUX1 selection for LUT2	0: from LUT3 1: from matrix (DLY IN)
	2887			DM1_1 Configuration Register 2 MUX2 selection for DLY input	0: from matrix (DLY IN) 1: from LUT3

GreenPAK Programmable Mixed-Signal Matrix with Asynchronous State Machine and Dual Supply
Table 56: Register Map (Continued)

Address		Signal Function	Register Bit Definition
Byte	Register Bit		
169	2888	DM1_1 Configuration Register 3 IN0 of LUT3	REG_MATRIX_LUT3_IN0_SEL[5:0]
	2889		
	2890		
	2891		
	2892		
	2893		
	2894		
16A	2895	DM1_1 Configuration Register 3 IN1 of LUT3	REG_MATRIX_LUT3_IN1_SEL[5:0]
	2896		
	2897		
	2898		
	2899		
	2900		
	2901		
16B	2902	DM1_1 Configuration Register 3 IN2 of LUT3	REG_MATRIX_LUT3_IN2_SEL[5:0]
	2903		
	2904		
	2905		
	2906		
	2907		
	2908		
16C	2909	DM1_1 Configuration Register 3 DLY input from matrix	DM Delay input
	2910		
	2911		
	2912		
	2913		
	2914		
	2915		
16D	2916	DM1_1 Configuration Register 3 Data of LUT3	REG_VAL_LUT3[0]
	2917		REG_VAL_LUT3[1]
	2918		REG_VAL_LUT3[2]
	2919		REG_VAL_LUT3[3]
	2920		REG_VAL_LUT3[4]
	2921		REG_VAL_LUT3[5]
	2922		REG_VAL_LUT3[6]
16D	2923	DM1_1 Configuration Register 3 Data of LUT2	REG_VAL_LUT3[7]
	2920		REG_VAL_LUT2[0]
	2921		REG_VAL_LUT2[1]
	2922		REG_VAL_LUT2[2]
	2923		REG_VAL_LUT2[3]

GreenPAK Programmable Mixed-Signal Matrix with Asynchronous State Machine and Dual Supply

Table 56: Register Map (Continued)

Address		Signal Function	Register Bit Definition
Byte	Register Bit		
16D	2924	DM1_1 Configuration Register 3 Clock source selection	Clock source sel[3:0] 0000: 25M; 0001: 25M/4; 0010: 2.048M 0011: 2.048M/8; 0100: 2.048M/64; 0101: 2.048M/512; 0110: 2.048K; 0111: 2.048K/8; 1000: 2.048K/64; 1001: 2.048K/512; 1010: 2.048K/4096 1011: 2.048K/32768; 1100: 2.048K/262144; 1101: CNT_END; 1110: External; 1111: External
	2925		
	2926		
	2927		
16E	2928	DM1_1 Configuration Register 3 Data of Delay	Data[7:0]
	2929		
	2930		
	2931		
	2932		
	2933		
	2934		
16F	2935	DM1_1 Configuration Register 3 DLY/CNT Function selection	00: bypass the initial 01: initial 0 10: initial 1 11: initial 1
	2936		
	2937		
	2938		
	2939		
	2940		
	2941		
	2942		
2943	DM1_1 Configuration Register 3 MUX2 selection for DLY input	0: from matrix (DLY IN) 1: from LUT3	

GreenPAK Programmable Mixed-Signal Matrix with Asynchronous State Machine and Dual Supply

Table 56: Register Map (Continued)

Address		Signal Function	Register Bit Definition		
Byte	Register Bit				
170	2944	DM1_1 Configuration Register 4 IN0 of LUT3	REG_MATRIX_LUT3_IN0_SEL[5:0]		
	2945				
	2946				
	2947				
	2948				
	2949				
	2950				
171	2951	DM1_1 Configuration Register 4 IN1 of LUT3	REG_MATRIX_LUT3_IN1_SEL[5:0]		
	2952				
	2953				
	2954				
	2955				
	2956				
	2957				
172	2958	DM1_1 Configuration Register 4 IN2 of LUT3	REG_MATRIX_LUT3_IN2_SEL[5:0]		
	2959				
	2960				
	2961				
	2962				
	2963				
	2964			DM1_1 Configuration Register 4 DLY input from matrix	DM Delay input
2965					
2966					
2967					
173	2968	DM1_1 Configuration Register 4 Data of LUT3	REG_VAL_LUT3[0]		
	2969		REG_VAL_LUT3[1]		
	2970		REG_VAL_LUT3[2]		
	2971		REG_VAL_LUT3[3]		
	2972		REG_VAL_LUT3[4]		
	2973		REG_VAL_LUT3[5]		
	2974		REG_VAL_LUT3[6]		
	2975		REG_VAL_LUT3[7]		
174	2976	DM1_1 Configuration Register 4 Data of LUT2	REG_VAL_LUT2[0]		
	2977		REG_VAL_LUT2[1]		
	2978		REG_VAL_LUT2[2]		
	2979		REG_VAL_LUT2[3]		

GreenPAK Programmable Mixed-Signal Matrix with Asynchronous State Machine and Dual Supply

Table 56: Register Map (Continued)

Address		Signal Function	Register Bit Definition
Byte	Register Bit		
174	2980	DM1_1 Configuration Register 4 Clock source selection	Clock source sel[3:0] 0000: 25M; 0001: 25M/4; 0010: 2.048M 0011: 2.048M/8; 0100: 2.048M/64; 0101: 2.048M/512; 0110: 2.048K; 0111: 2.048K/8; 1000: 2.048K/64; 1001: 2.048K/512; 1010: 2.048K/4096 1011: 2.048K/32768; 1100: 2.048K/262144; 1101: CNT_END; 1110: External; 1111: External
	2981		
	2982		
	2983		
175	2984	DM1_1 Configuration Register 4 Data of Delay	Data[7:0]
	2985		
	2986		
	2987		
	2988		
	2989		
	2990		
176	2991		
	2992	DM1_1 Configuration Register 4 DLY input initial selection	00: bypass the initial 01: initial 0 10: initial 1 11: initial 1
	2993		
	2994	DM1_1 Configuration Register 4 DLY/CNT Function selection	0000: Both Edge Delay 0001: Falling Edge Delay 0010: Rising Edge Delay 0011: Both Edge One Shot 0100: Falling Edge One Shot 0101: Rising Edge One Shot 0110: Both Edge Freq Detect 0111: Falling Edge Freq Detect 1000: Rising Edge Freq Detect 1001: Both Edge Detect 1010: Falling Edge Detect 1011: Rising Edge Detect 1100: Both Edge Reset CNT 1101: Falling Edge Reset CNT 1110: Rising Edge Reset CNT 1111: High Level Reset CNT
	2995		
	2996		
	2997		
	2998		
	2999	DM1_1 Configuration Register 4 MUX2 selection for DLY input	0: from matrix (DLY IN) 1: from LUT3

GreenPAK Programmable Mixed-Signal Matrix with Asynchronous State Machine and Dual Supply

Table 56: Register Map (Continued)

Address		Signal Function	Register Bit Definition		
Byte	Register Bit				
177	3000	DM1_1 Configuration Register 5 IN0 of LUT3	REG_MATRIX_LUT3_IN0_SEL[5:0]		
	3001				
	3002				
	3003				
	3004				
	3005				
	3006				
178	3007	DM1_1 Configuration Register 5 IN1 of LUT3	REG_MATRIX_LUT3_IN1_SEL[5:0]		
	3008				
	3009				
	3010				
	3011				
	3012				
	3013				
179	3014	DM1_1 Configuration Register 5 IN2 of LUT3	REG_MATRIX_LUT3_IN2_SEL[5:0]		
	3015				
	3016				
	3017				
	3018				
	3019				
	3020			DM1_1 Configuration Register 5 DLY input from matrix	DM Delay input
3021					
3022					
3023					
17A	3024	DM1_1 Configuration Register 5 Data of LUT3	REG_VAL_LUT3[0]		
	3025		REG_VAL_LUT3[1]		
	3026		REG_VAL_LUT3[2]		
	3027		REG_VAL_LUT3[3]		
	3028		REG_VAL_LUT3[4]		
	3029		REG_VAL_LUT3[5]		
	3030		REG_VAL_LUT3[6]		
3031	REG_VAL_LUT3[7]				
17B	3032	DM1_1 Configuration Register 5 Data of LUT2	REG_VAL_LUT2[0]		
	3033		REG_VAL_LUT2[1]		
	3034		REG_VAL_LUT2[2]		
	3035		REG_VAL_LUT2[3]		

GreenPAK Programmable Mixed-Signal Matrix with Asynchronous State Machine and Dual Supply

Table 56: Register Map (Continued)

Address		Signal Function	Register Bit Definition		
Byte	Register Bit				
17B	3036	DM1_1 Configuration Register 5 Clock source selection	Clock source sel[3:0] 0000: 25M; 0001: 25M/4; 0010: 2.048M 0011: 2.048M/8; 0100: 2.048M/64; 0101: 2.048M/512; 0110: 2.048K; 0111: 2.048K/8; 1000: 2.048K/64; 1001: 2.048K/512; 1010: 2.048K/4096 1011: 2.048K/32768; 1100: 2.048K/262144; 1101: CNT_END; 1110: External; 1111: External		
	3037				
	3038				
	3039				
17C	3040	DM1_1 Configuration Register 5 Data of Delay	Data[7:0]		
	3041				
	3042				
	3043				
	3044				
	3045				
	3046				
	3047				
17D	3048	DM1_1 Configuration Register 5 DLY input initial selection	00: bypass the initial 01: initial 0 10: initial 1 11: initial 1		
	3049				
	3050	DM1_1 Configuration Register 5 DLY/CNT Function selection	0000: Both Edge Delay 0001: Falling Edge Delay 0010: Rising Edge Delay 0011: Both Edge One Shot 0100: Falling Edge One Shot 0101: Rising Edge One Shot 0110: Both Edge Freq Detect 0111: Falling Edge Freq Detect 1000: Rising Edge Freq Detect 1001: Both Edge Detect 1010: Falling Edge Detect 1011: Rising Edge Detect 1100: Both Edge Reset CNT 1101: Falling Edge Reset CNT 1110: Rising Edge Reset CNT 1111: High Level Reset CNT		
	3051				
	3052				
	3053				
	3054			DM1_1 Configuration Register 5 MUX1 selection for LUT2	0: from LUT3 1: from matrix (DLY IN)
	3055			DM1_1 Configuration Register 5 MUX2 selection for DLY input	0: from matrix (DLY IN) 1: from LUT3

GreenPAK Programmable Mixed-Signal Matrix with Asynchronous State Machine and Dual Supply

Table 56: Register Map (Continued)

Address		Signal Function	Register Bit Definition
Byte	Register Bit		
17E	3056	DM0_0 Selection Register State 0, bit [0]	selection bit[2:0]: 000: Not Used 001: DM0_0 Configuration Register 0 010: DM0_0 Configuration Register 1 011: DM0_0 Configuration Register 2 100: DM0_0 Configuration Register 3 101: DM0_0 Configuration Register 4 110: DM0_0 Configuration Register 5 111: Not Used
	3057	DM0_0 Selection Register State 1, bit [0]	
	3058	DM0_0 Selection Register State 2, bit [0]	
	3059	DM0_0 Selection Register State 3, bit [0]	
	3060	DM0_0 Selection Register State 4, bit [0]	
	3061	DM0_0 Selection Register State 5, bit [0]	
	3062	DM0_0 Selection Register State 6, bit [0]	
	3063	DM0_0 Selection Register State 7, bit [0]	
17F	3064	DM0_0 Selection Register State 8, bit [0]	
	3065	DM0_0 Selection Register State 9, bit [0]	
	3066	DM0_0 Selection Register State 10, bit [0]	
	3067	DM0_0 Selection Register State 11, bit [0]	
	3068	DM0_0 Selection Register State 0, bit [1]	
	3069	DM0_0 Selection Register State 1, bit [1]	
	3070	DM0_0 Selection Register State 2, bit [1]	
180	3071	DM0_0 Selection Register State 3, bit [1]	
	3072	DM0_0 Selection Register State 4, bit [1]	
	3073	DM0_0 Selection Register State 5, bit [1]	
	3074	DM0_0 Selection Register State 6, bit [1]	
	3075	DM0_0 Selection Register State 7, bit [1]	
	3076	DM0_0 Selection Register State 8, bit [1]	
	3077	DM0_0 Selection Register State 9, bit [1]	
	3078	DM0_0 Selection Register State 10, bit [1]	
181	3079	DM0_0 Selection Register State 11, bit [1]	
	3080	DM0_0 Selection Register State 0, bit [2]	
	3081	DM0_0 Selection Register State 1, bit [2]	
	3082	DM0_0 Selection Register State 2, bit [2]	
	3083	DM0_0 Selection Register State 3, bit [2]	
	3084	DM0_0 Selection Register State 4, bit [2]	
	3085	DM0_0 Selection Register State 5, bit [2]	
182	3086	DM0_0 Selection Register State 6, bit [2]	
	3087	DM0_0 Selection Register State 7, bit [2]	
	3088	DM0_0 Selection Register State 8, bit [2]	
	3089	DM0_0 Selection Register State 9, bit [2]	
	3090	DM0_0 Selection Register State 10, bit [2]	
	3091	DM0_0 Selection Register State 11, bit [2]	

GreenPAK Programmable Mixed-Signal Matrix with Asynchronous State Machine and Dual Supply

Table 56: Register Map (Continued)

Address		Signal Function	Register Bit Definition
Byte	Register Bit		
182	3092	DM0_0 Output Configuration Selection Register State 0, bit [0]	control bit[1:0]: 00:DM out0/1/2 keep 01:DM out bypass to out0, out1/2 keep 10: DM out bypass to out1, out0/2 keep 11: DM out bypass to out2, out0/1 keep
	3093	DM0_0 Output Configuration Selection Register State 1, bit [0]	
	3094	DM0_0 Output Configuration Selection Register State 2, bit [0]	
	3095	DM0_0 Output Configuration Selection Register State 3, bit [0]	
183	3096	DM0_0 Output Configuration Selection Register State 4, bit [0]	
	3097	DM0_0 Output Configuration Selection Register State 5, bit [0]	
	3098	DM0_0 Output Configuration Selection Register State 6, bit [0]	
	3099	DM0_0 Output Configuration Selection Register State 7, bit [0]	
	3100	DM0_0 Output Configuration Selection Register State 8, bit [0]	
	3101	DM0_0 Output Configuration Selection Register State 9, bit [0]	
	3102	DM0_0 Output Configuration Selection Register State 10, bit [0]	
	3103	DM0_0 Output Configuration Selection Register State 11, bit [0]	
184	3104	DM0_0 Output Configuration Selection Register State 0, bit [1]	control bit[1:0]: 00:DM out0/1/2 keep 01:DM out bypass to out0, out1/2 keep 10: DM out bypass to out1, out0/2 keep 11: DM out bypass to out2, out0/1 keep
	3105	DM0_0 Output Configuration Selection Register State 1, bit [1]	
	3106	DM0_0 Output Configuration Selection Register State 2, bit [1]	
	3107	DM0_0 Output Configuration Selection Register State 3, bit [1]	
	3108	DM0_0 Output Configuration Selection Register State 4, bit [1]	
	3109	DM0_0 Output Configuration Selection Register State 5, bit [1]	
	3110	DM0_0 Output Configuration Selection Register State 6, bit [1]	
	3111	DM0_0 Output Configuration Selection Register State 7, bit [1]	
185	3112	DM0_0 Output Configuration Selection Register State 8, bit [1]	
	3113	DM0_0 Output Configuration Selection Register State 9, bit [1]	
	3114	DM0_0 Output Configuration Selection Register State 10, bit [1]	
	3115	DM0_0 Output Configuration Selection Register State 11, bit [1]	

GreenPAK Programmable Mixed-Signal Matrix with Asynchronous State Machine and Dual Supply

Table 56: Register Map (Continued)

Address		Signal Function	Register Bit Definition	
Byte	Register Bit			
185	3116	DM1_0 Selection Register State 0, bit [0]	selection bit[2:0]: 000: Not Used 001: DM1_0 Configuration Register 0 010: DM1_0 Configuration Register 1 011: DM1_0 Configuration Register 2 100: DM1_0 Configuration Register 3 101: DM1_0 Configuration Register 4 110: DM1_0 Configuration Register 5 111: Not Used	
	3117	DM1_0 Selection Register State 1, bit [0]		
	3118	DM1_0 Selection Register State 2, bit [0]		
	3119	DM1_0 Selection Register State 3, bit [0]		
186	3120	DM1_0 Selection Register State 4, bit [0]		
	3121	DM1_0 Selection Register State 5, bit [0]		
	3122	DM1_0 Selection Register State 6, bit [0]		
	3123	DM1_0 Selection Register State 7, bit [0]		
	3124	DM1_0 Selection Register State 8, bit [0]		
	3125	DM1_0 Selection Register State 9, bit [0]		
	3126	DM1_0 Selection Register State 10, bit [0]		
	3127	DM1_0 Selection Register State 11, bit [0]		
187	3128	DM1_0 Selection Register State 0, bit [1]	selection bit[2:0]: 000: Not Used 001: DM1_0 Configuration Register 0 010: DM1_0 Configuration Register 1 011: DM1_0 Configuration Register 2 100: DM1_0 Configuration Register 3 101: DM1_0 Configuration Register 4 110: DM1_0 Configuration Register 5 111: Not Used	
	3129	DM1_0 Selection Register State 1, bit [1]		
	3130	DM1_0 Selection Register State 2, bit [1]		
	3131	DM1_0 Selection Register State 3, bit [1]		
	3132	DM1_0 Selection Register State 4, bit [1]		
	3133	DM1_0 Selection Register State 5, bit [1]		
	3134	DM1_0 Selection Register State 6, bit [1]		
	3135	DM1_0 Selection Register State 7, bit [1]		
188	3136	DM1_0 Selection Register State 8, bit [1]		selection bit[2:0]: 000: Not Used 001: DM1_0 Configuration Register 0 010: DM1_0 Configuration Register 1 011: DM1_0 Configuration Register 2 100: DM1_0 Configuration Register 3 101: DM1_0 Configuration Register 4 110: DM1_0 Configuration Register 5 111: Not Used
	3137	DM1_0 Selection Register State 9, bit [1]		
	3138	DM1_0 Selection Register State 10, bit [1]		
	3139	DM1_0 Selection Register State 11, bit [1]		
	3140	DM1_0 Selection Register State 0, bit [2]		
	3141	DM1_0 Selection Register State 1, bit [2]		
	3142	DM1_0 Selection Register State 2, bit [2]		
	3143	DM1_0 Selection Register State 3, bit [2]		
189	3144	DM1_0 Selection Register State 4, bit [2]	selection bit[2:0]: 000: Not Used 001: DM1_0 Configuration Register 0 010: DM1_0 Configuration Register 1 011: DM1_0 Configuration Register 2 100: DM1_0 Configuration Register 3 101: DM1_0 Configuration Register 4 110: DM1_0 Configuration Register 5 111: Not Used	
	3145	DM1_0 Selection Register State 5, bit [2]		
	3146	DM1_0 Selection Register State 6, bit [2]		
	3147	DM1_0 Selection Register State 7, bit [2]		
	3148	DM1_0 Selection Register State 8, bit [2]		
	3149	DM1_0 Selection Register State 9, bit [2]		
	3150	DM1_0 Selection Register State 10, bit [2]		
	3151	DM1_0 Selection Register State 11, bit [2]		

GreenPAK Programmable Mixed-Signal Matrix with Asynchronous State Machine and Dual Supply

Table 56: Register Map (Continued)

Address		Signal Function	Register Bit Definition
Byte	Register Bit		
18A	3152	DM0_1 Selection Register State 0, bit [0]	selection bit[2:0]: 000: Not Used 001: DM0_1 Configuration Register 0 010: DM0_1 Conflagration Register 1 011: DM0_1 Configuration Register 2 100: DM0_1 Configuration Register 3 101: DM0_1 Configuration Register 4 110: DM0_1 Configuration Register 5 111: Not Used
	3153	DM0_1 Selection Register State 1, bit [0]	
	3154	DM0_1 Selection Register State 2, bit [0]	
	3155	DM0_1 Selection Register State 3, bit [0]	
	3156	DM0_1 Selection Register State 4, bit [0]	
	3157	DM0_1 Selection Register State 5, bit [0]	
	3158	DM0_1 Selection Register State 6, bit [0]	
	3159	DM0_1 Selection Register State 7, bit [0]	
18B	3160	DM0_1 Selection Register State 8, bit [0]	
	3161	DM0_1 Selection Register State 9, bit [0]	
	3162	DM0_1 Selection Register State 10, bit [0]	
	3163	DM0_1 Selection Register State 11, bit [0]	
	3164	DM0_1 Selection Register State 0, bit [1]	
	3165	DM0_1 Selection Register State 1, bit [1]	
	3166	DM0_1 Selection Register State 2, bit [1]	
	3167	DM0_1 Selection Register State 3, bit [1]	
18C	3168	DM0_1 Selection Register State 4, bit [1]	
	3169	DM0_1 Selection Register State 5, bit [1]	
	3170	DM0_1 Selection Register State 6, bit [1]	
	3171	DM0_1 Selection Register State 7, bit [1]	
	3172	DM0_1 Selection Register State 8, bit [1]	
	3173	DM0_1 Selection Register State 9, bit [1]	
	3174	DM0_1 Selection Register State 10, bit [1]	
	3175	DM0_1 Selection Register State 11, bit [1]	
18D	3176	DM0_1 Selection Register State 0, bit [2]	
	3177	DM0_1 Selection Register State 1, bit [2]	
	3178	DM0_1 Selection Register State 2, bit [2]	
	3179	DM0_1 Selection Register State 3, bit [2]	
	3180	DM0_1 Selection Register State 4, bit [2]	
	3181	DM0_1 Selection Register State 5, bit [2]	
	3182	DM0_1 Selection Register State 6, bit [2]	
	3183	DM0_1 Selection Register State 7, bit [2]	
18E	3184	DM0_1 Selection Register State 8, bit [2]	
	3185	DM0_1 Selection Register State 9, bit [2]	
	3186	DM0_1 Selection Register State 10, bit [2]	
	3187	DM0_1 Selection Register State 11, bit [2]	

GreenPAK Programmable Mixed-Signal Matrix with Asynchronous State Machine and Dual Supply

Table 56: Register Map (Continued)

Address		Signal Function	Register Bit Definition
Byte	Register Bit		
18E	3188	DM0_1 Output Configuration Selection Register State 0, bit [0]	control bit[1:0]: 00:DM out0/1/2 keep 01:DM out bypass to out0, out1/2 keep 10: DM out bypass to out1, out0/2 keep 11: DM out bypass to out2, out0/1 keep
	3189	DM0_1 Output Configuration Selection Register State 1, bit [0]	
	3190	DM0_1 Output Configuration Selection Register State 2, bit [0]	
	3191	DM0_1 Output Configuration Selection Register State 3, bit [0]	
18F	3192	DM0_1 Output Configuration Selection Register State 4, bit [0]	
	3193	DM0_1 Output Configuration Selection Register State 5, bit [0]	
	3194	DM0_1 Output Configuration Selection Register State 6, bit [0]	
	3195	DM0_1 Output Configuration Selection Register State 7, bit [0]	
	3196	DM0_1 Output Configuration Selection Register State 8, bit [0]	
	3197	DM0_1 Output Configuration Selection Register State 9, bit [0]	
	3198	DM0_1 Output Configuration Selection Register State 10, bit [0]	
	3199	DM0_1 Output Configuration Selection Register State 11, bit [0]	

GreenPAK Programmable Mixed-Signal Matrix with Asynchronous State Machine and Dual Supply

Table 56: Register Map (Continued)

Address		Signal Function	Register Bit Definition	
Byte	Register Bit			
190	3200	DM0_1 Output Configuration Selection Register State 0, bit [1]	control bit[1:0]: 00:DM out0/1/2 keep 01:DM out bypass to out0, out1/2 keep 10: DM out bypass to out1, out0/2 keep 11: DM out bypass to out2, out0/1 keep	
	3201	DM0_1 Output Configuration Selection Register State 1, bit [1]		
	3202	DM0_1 Output Configuration Selection Register State 2, bit [1]		
	3203	DM0_1 Output Configuration Selection Register State 3, bit [1]		
	3204	DM0_1 Output Configuration Selection Register State 4, bit [1]		
	3205	DM0_1 Output Configuration Selection Register State 5, bit [1]		
	3206	DM0_1 Output Configuration Selection Register State 6, bit [1]		
	3207	DM0_1 Output Configuration Selection Register State 7, bit [1]		
191	3208	DM0_1 Output Configuration Selection Register State 8, bit [1]		
	3209	DM0_1 Output Configuration Selection Register State 9, bit [1]		
	3210	DM0_1 Output Configuration Selection Register State 10, bit [1]		
	3211	DM0_1 Output Configuration Selection Register State 11, bit [1]		
	3212	DM1_1 Selection Register State 0, bit [0]		selection bit[2:0]: 000: Not Used 001: DM1_1 Configuration Register 0 010: DM1_1 Conflagration Register 1 011: DM1_1 Configuration Register 2 100: DM1_1 Configuration Register 3 101: DM1_1 Configuration Register 4 110: DM1_1 Configuration Register 5 111: Not Used
	3213	DM1_1 Selection Register State 1, bit [0]		
	3214	DM1_1 Selection Register State 2, bit [0]		
3215	DM1_1 Selection Register State 3, bit [0]			
192	3216	DM1_1 Selection Register State 4, bit [0]		
	3217	DM1_1 Selection Register State 5, bit [0]		
	3218	DM1_1 Selection Register State 6, bit [0]		
	3219	DM1_1 Selection Register State 7, bit [0]		
	3220	DM1_1 Selection Register State 8, bit [0]		
	3221	DM1_1 Selection Register State 9, bit [0]		
	3222	DM1_1 Selection Register State 10, bit [0]		
	3223	DM1_1 Selection Register State 11, bit [0]		

GreenPAK Programmable Mixed-Signal Matrix with Asynchronous State Machine and Dual Supply

Table 56: Register Map (Continued)

Address		Signal Function	Register Bit Definition
Byte	Register Bit		
193	3224	DM1_1 Selection Register State 0, bit [1]	selection bit[2:0]: 000: Not Used 001: DM1_1 Configuration Register 0 010: DM1_1 Conflagration Register 1 011: DM1_1 Configuration Register 2 100: DM1_1 Configuration Register 3 101: DM1_1 Configuration Register 4 110: DM1_1 Configuration Register 5 111: Not Used
	3225	DM1_1 Selection Register State 1, bit [1]	
	3226	DM1_1 Selection Register State 2, bit [1]	
	3227	DM1_1 Selection Register State 3, bit [1]	
	3228	DM1_1 Selection Register State 4, bit [1]	
	3229	DM1_1 Selection Register State 5, bit [1]	
	3230	DM1_1 Selection Register State 6, bit [1]	
	3231	DM1_1 Selection Register State 7, bit [1]	
194	3232	DM1_1 Selection Register State 8, bit [1]	
	3233	DM1_1 Selection Register State 9, bit [1]	
	3234	DM1_1 Selection Register State 10, bit [1]	
	3235	DM1_1 Selection Register State 11, bit [1]	
	3236	DM1_1 Selection Register State 0, bit [2]	
	3237	DM1_1 Selection Register State 1, bit [2]	
	3238	DM1_1 Selection Register State 2, bit [2]	
195	3239	DM1_1 Selection Register State 3, bit [2]	
	3240	DM1_1 Selection Register State 4, bit [2]	
	3241	DM1_1 Selection Register State 5, bit [2]	
	3242	DM1_1 Selection Register State 6, bit [2]	
	3243	DM1_1 Selection Register State 7, bit [2]	
	3244	DM1_1 Selection Register State 8, bit [2]	
	3245	DM1_1 Selection Register State 9, bit [2]	
	3246	DM1_1 Selection Register State 10, bit [2]	
196	3247	DM1_1 Selection Register State 11, bit [2]	
	3248	DM0_0 function 4 outputs initial value	0: initial 0 1: initial 1
	3249	DM0_1 function 4 outputs initial value	0: initial 0 1: initial 1
	3250	Reserved	
	3251	Reserved	
	3252	Reserved	
	3253	Reserved	
	3254	Reserved	
197	3255	Reserved	
	3256	Reserved	
	3257	Reserved	
	3258	Reserved	
	3259	Reserved	
	3260	VrefO0 register PD control	Vrefo0 register Power-down signal 0: Power-down, 1: Power-On
3261	VrefO0 PD control select	Vrefo0 pd selection 0: from register [3260], 1: from matrix out 78	

GreenPAK Programmable Mixed-Signal Matrix with Asynchronous State Machine and Dual Supply

Table 56: Register Map (Continued)

Address		Signal Function	Register Bit Definition
Byte	Register Bit		
197	3262	VrefO1 register PD control	Vrefo1 register Power-down signal 0: Power-down, 1: Power-On
	3263	VrefO1 PD control select	Vrefo1 pd selection 0: from register [3262], 1: from matrix out 78
198	3264	F1 stack memory, lower byte	Bit0 (top memory)
	3265		Bit1
	3266		Bit2
	3267		Bit3
	3268		Bit4
	3269		Bit5
	3270		Bit6
	3271		Bit7
199	3272	F1 stack memory, higher byte	Bit8
	3273		Bit9
	3274		Bit10
	3275		Bit11
	3276		Bit12
	3277		Bit13
	3278		Bit14
	3279		Bit15
19A	3280	aio0-3 input selection load 1	00: aio0 01: aio1 10: aio2 11: aio3
	3281		
	3282	ACMP4_F Vref selection load 1	"F1 input selection load 1" bit = 0: Matrix input select: 000000: Matrix in0; ~ 111111: Matrix in63
	3283		"F1 input selection load 1" bit = 1: ACMP Vref select: 000000: 32 mV ~ 111110: 2.016 V/step = 32 mV; 111111: External Vref
	3284		
	3285		
	3286		
	3287		
19B	3288	aio0-3 input selection load 2	00: aio0 01: aio1 10: aio2 11: aio3
	3289		
	3290	ACMP4_F Vref selection load 2	"F1 input selection load 1" bit = 0: Matrix input select: 000000: Matrix in0; ~ 111111: Matrix in63
	3291		"F1 input selection load 1" bit = 1: ACMP Vref select: 000000: 32 mV ~ 111110: 2.016 V/step = 32 mV; 111111: External Vref
	3292		
	3293		
	3294		
3295			
19C	3296	aio4-7 input selection load 3	00: aio4 01: aio5 10: aio6 11: aio7
	3297		

GreenPAK Programmable Mixed-Signal Matrix with Asynchronous State Machine and Dual Supply

Table 56: Register Map (Continued)

Address		Signal Function	Register Bit Definition
Byte	Register Bit		
19C	3298	ACMP4_F Vref selection load 3	"F1 input selection load 1" bit = 0: Matrix input select: 000000: Matrix in0; ~ 111111: Matrix in63 "F1 input selection load 1" bit = 1: ACMP Vref select: 000000: 32 mV ~ 111110: 2.016 V/step = 32 mV; 111111: External Vref
	3299		
	3300		
	3301		
	3302		
	3303		
19D	3304	aio4-7 input selection load 4	00: aio4 01: aio5 10: aio6 11: aio7
	3305		
	3306	ACMP4_F Vref selection load 4	"F1 input selection load 1" bit = 0: Matrix input select: 000000: Matrix in0; ~ 111111: Matrix in63 "F1 input selection load 1" bit = 1: ACMP Vref select: 000000: 32 mV ~ 111110: 2.016 V/step = 32 mV; 111111: External Vref
	3307		
	3308		
	3309		
	3310		
3311			
19E	3312	F1 input selection load 1	0: from matrix 1: from ACMP4_F
	3313	F1 input selection load 2	0: from matrix 1: from ACMP4_F
	3314	F1 input selection load 3	0: from matrix 1: from ACMP4_F
	3315	F1 input selection load 4	0: from matrix 1: from ACMP4_F
	3316	Reserved	
	3317	delay clock source selection	000: OSC2 001: OSC2/4 010: OSC1 011: OSC1/8 100: OSC1/64 101: OSC0 110: OSC0/8 111: OSC0/64
	3318		
3319			
19F	3320	F1 delay data	Data[7:0]
	3321		
	3322		
	3323		
	3324		
	3325		
	3326		
3327			
1A0	3328	F1 CMD1 selection	0000:load1;0001:load2;0010:load3;0011:load4;0100:and;0101:or;0110:xor;0111:inv;1000:push0;1001:pop;1010:delay;1011:delay with loop;1100:out1;1101:out2;1110:out3; 1111:end.
	3329		
	3330		
	3331		

GreenPAK Programmable Mixed-Signal Matrix with Asynchronous State Machine and Dual Supply

Table 56: Register Map (Continued)

Address		Signal Function	Register Bit Definition
Byte	Register Bit		
1A0	3332	F1 CMD2 selection	0000:load1;0001:load2;0010:load3;0011:load4;0100:and;0101:or;0110:xor;0111:inv;1000:push0;1001:pop;1010:delay;1011:delay with loop;1100:out1;1101:out2;1110:out3; 1111:end.
	3333		
	3334		
	3335		
1A1	3336	F1 CMD3 selection	0000:load1;0001:load2;0010:load3;0011:load4;0100:and;0101:or;0110:xor;0111:inv;1000:push0;1001:pop;1010:delay;1011:delay with loop;1100:out1;1101:out2;1110:out3; 1111:end.
	3337		
	3338		
	3339		
	3340	F1 CMD4 selection	0000:load1;0001:load2;0010:load3;0011:load4;0100:and;0101:or;0110:xor;0111:inv;1000:push0;1001:pop;1010:delay;1011:delay with loop;1100:out1;1101:out2;1110:out3; 1111:end.
	3341		
	3342		
	3343		
1A2	3344	F1 CMD5 selection	0000:load1;0001:load2;0010:load3;0011:load4;0100:and;0101:or;0110:xor;0111:inv;1000:push0;1001:pop;1010:delay;1011:delay with loop;1100:out1;1101:out2;1110:out3; 1111:end.
	3345		
	3346		
	3347		
	3348	F1 CMD6 selection	0000:load1;0001:load2;0010:load3;0011:load4;0100:and;0101:or;0110:xor;0111:inv;1000:push0;1001:pop;1010:delay;1011:delay with loop;1100:out1;1101:out2;1110:out3; 1111:end.
	3349		
	3350		
	3351		
1A3	3352	F1 CMD7 selection	0000:load1;0001:load2;0010:load3;0011:load4;0100:and;0101:or;0110:xor;0111:inv;1000:push0;1001:pop;1010:delay;1011:delay with loop;1100:out1;1101:out2;1110:out3; 1111:end.
	3353		
	3354		
	3355		
	3356	F1 CMD8 selection	0000:load1;0001:load2;0010:load3;0011:load4;0100:and;0101:or;0110:xor;0111:inv;1000:push0;1001:pop;1010:delay;1011:delay with loop;1100:out1;1101:out2;1110:out3; 1111:end.
	3357		
	3358		
	3359		
1A4	3360	F1 CMD9 selection	0000:load1;0001:load2;0010:load3;0011:load4;0100:and;0101:or;0110:xor;0111:inv;1000:push0;1001:pop;1010:delay;1011:delay with loop;1100:out1;1101:out2;1110:out3; 1111:end.
	3361		
	3362		
	3363		
	3364	F1 CMD10 selection	0000:load1;0001:load2;0010:load3;0011:load4;0100:and;0101:or;0110:xor;0111:inv;1000:push0;1001:pop;1010:delay;1011:delay with loop;1100:out1;1101:out2;1110:out3; 1111:end.
	3365		
	3366		
	3367		
1A5	3368	F1 CMD11 selection	0000:load1;0001:load2;0010:load3;0011:load4;0100:and;0101:or;0110:xor;0111:inv;1000:push0;1001:pop;1010:delay;1011:delay with loop;1100:out1;1101:out2;1110:out3; 1111:end.
	3369		
	3370		
	3371		

GreenPAK Programmable Mixed-Signal Matrix with Asynchronous State Machine and Dual Supply

Table 56: Register Map (Continued)

Address		Signal Function	Register Bit Definition
Byte	Register Bit		
1A5	3372	F1 CMD12 selection	0000:load1;0001:load2;0010:load3;0011:load4;0100:and;0101:or;0110:xor;0111:inv;1000:push0;1001:pop;1010:delay;1011:delay with loop;1100:out1;1101:out2;1110:out3; 1111:end.
	3373		
	3374		
	3375		
1A6	3376	loop with delay to location selection	0000:CMD1;0001:CMD2;0010:CMD3;0011:CMD4;0100:CMD5;0101:CMD6;or;0110:CMD7;0111:CMD8;1000:CMD9;1001:CMD10;1010:CMD11;1011:CMD12
	3377		
	3378		
	3379		
	3380	output mux1 initial state setting	00: keep 01: 0 10: 1 11: none
	3381		
	3382	output mux2 initial state setting	00: keep 01: 0 10: 1 11: none
3383			
1A7	3384	output mux3 initial state setting	00: keep 01: 0 10: 1 11: none
	3385		
	3386	interrupt reset stack memory enable	0: no reset stack memory 1: reset stack memory
	3387	Reserved	
	3388	Reserved	
	3389	Reserved	
	3390	Reserved	
	3391	Reserved	
1A8	3392	aio0-3 input selection load 1	00: aio0 01: aio1 10: aio2 11: aio3
	3393		
	3394	ACMP4_F Vref selection load 1	"F1 input selection load 1" bit = 0: Matrix input select: 000000: Matrix in0; ~ 111111: Matrix in63 "F1 input selection load 1" bit = 1: ACMP Vref select: 000000: 32 mV ~ 111110: 2.016 V/step = 32 mV; 111111: External Vref
	3395		
	3396		
	3397		
	3398		
3399			
1A9	3400	aio0-3 input selection load 2	00: aio0 01: aio1 10: aio2 11: aio3
	3401		

GreenPAK Programmable Mixed-Signal Matrix with Asynchronous State Machine and Dual Supply

Table 56: Register Map (Continued)

Address		Signal Function	Register Bit Definition
Byte	Register Bit		
1A9	3402	ACMP4_F Vref selection load 2	"F1 input selection load 1" bit = 0: Matrix input select: 000000: Matrix in0; ~ 111111: Matrix in63 "F1 input selection load 1" bit = 1: ACMP Vref select: 000000: 32 mV ~ 111110: 2.016 V/step = 32 mV; 111111: External Vref
	3403		
	3404		
	3405		
	3406		
	3407		
1AA	3408	aio4-7 input selection load 3	00: aio4 01: aio5 10: aio6 11: aio7
	3409		
	3410	ACMP4_F Vref selection load 3	"F1 input selection load 1" bit = 0: Matrix input select: 000000: Matrix in0; ~ 111111: Matrix in63 "F1 input selection load 1" bit = 1: ACMP Vref select: 000000: 32 mV ~ 111110: 2.016 V/step = 32 mV; 111111: External Vref
	3411		
	3412		
	3413		
	3414		
	3415		
1AB	3416	aio4-7 input selection load 4	00: aio4 01: aio5 10: aio6 11: aio7
	3417		
	3418	ACMP4_F Vref selection load 4	"F1 input selection load 1" bit = 0: Matrix input select: 000000: Matrix in0; ~ 111111: Matrix in63 "F1 input selection load 1" bit = 1: ACMP Vref select: 000000: 32 mV ~ 111110: 2.016 V/step = 32 mV; 111111: External Vref
	3419		
	3420		
	3421		
	3422		
	3423		
1AC	3424	F1 input selection load 1	0: from matrix 1: from ACMP4_F
	3425	F1 input selection load 2	0: from matrix 1: from ACMP4_F
	3426	F1 input selection load 3	0: from matrix 1: from ACMP4_F
	3427	F1 input selection load 4	0: from matrix 1: from ACMP4_F
	3428	Reserved	
	3429	delay clock source selection	000: OSC2 001: OSC2/4 010: OSC1 011: OSC1/8 100: OSC1/64 101: OSC0 110: OSC0/8 111: OSC0/64
	3430		
	3431		

GreenPAK Programmable Mixed-Signal Matrix with Asynchronous State Machine and Dual Supply

Table 56: Register Map (Continued)

Address		Signal Function	Register Bit Definition
Byte	Register Bit		
1AD	3432	F1 delay data	Data[7:0]
	3433		
	3434		
	3435		
	3436		
	3437		
	3438		
	3439		
1AE	3440	F1 CMD1 selection	0000:load1;0001:load2;0010:load3;0011:load4;0100:and;0101:or;0110:xor;0111:inv;1000:push0;1001:pop;1010:delay;1011:delay with loop;1100:out1;1101:out2;1110:out3; 1111:end.
	3441		
	3442		
	3443		
	3444	F1 CMD2 selection	
	3445		
	3446		
	3447		
1AF	3448	F1 CMD3 selection	0000:load1;0001:load2;0010:load3;0011:load4;0100:and;0101:or;0110:xor;0111:inv;1000:push0;1001:pop;1010:delay;1011:delay with loop;1100:out1;1101:out2;1110:out3; 1111:end.
	3449		
	3450		
	3451		
	3452	F1 CMD4 selection	
	3453		
	3454		
	3455		
1B0	3456	F1 CMD5 selection	0000:load1;0001:load2;0010:load3;0011:load4;0100:and;0101:or;0110:xor;0111:inv;1000:push0;1001:pop;1010:delay;1011:delay with loop;1100:out1;1101:out2;1110:out3; 1111:end.
	3457		
	3458		
	3459		
	3460	F1 CMD6 selection	
	3461		
	3462		
	3463		
1B1	3464	F1 CMD7 selection	0000:load1;0001:load2;0010:load3;0011:load4;0100:and;0101:or;0110:xor;0111:inv;1000:push0;1001:pop;1010:delay;1011:delay with loop;1100:out1;1101:out2;1110:out3; 1111:end.
	3465		
	3466		
	3467		
	3468	F1 CMD8 selection	
	3469		
	3470		
	3471		

GreenPAK Programmable Mixed-Signal Matrix with Asynchronous State Machine and Dual Supply

Table 56: Register Map (Continued)

Address		Signal Function	Register Bit Definition	
Byte	Register Bit			
1B2	3472	F1 CMD9 selection	0000:load1;0001:load2;0010:load3;0011:load4;0100:and;0101:or;0110:xor;0111:inv;1000:push0;1001:pop;1010:delay;1011:delay with loop;1100:out1;1101:out2;1110:out3; 1111:end.	
	3473			
	3474			
	3475			
	3476	F1 CMD10 selection		
	3477			
	3478			
	3479			
1B3	3480	F1 CMD11 selection	0000:load1;0001:load2;0010:load3;0011:load4;0100:and;0101:or;0110:xor;0111:inv;1000:push0;1001:pop;1010:delay;1011:delay with loop;1100:out1;1101:out2;1110:out3; 1111:end.	
	3481			
	3482			
	3483			
	3484	F1 CMD12 selection		
	3485			
	3486			
	3487			
1B4	3488	loop with delay to location selection	0000:CMD1;0001:CMD2;0010:CMD3;0011:CMD4;0100:CMD5;0101:CMD6;or;0110:CMD7;0111:CMD8;1000:CMD9;1001:CMD10;1010:CMD11;1011:CMD12	
	3489			
	3490			
	3491			
	3492	output mux1 initial state setting		
	3493			
	3494			
	3495			
1B5	3496	output mux3 initial state setting	00: keep 01: 0 10: 1 11: none	
	3497			
	3498	interrupt reset stack memory enable		0: no reset stack memory 1: reset stack memory.
	3499	Reserved		
	3500	Reserved		
	3501	Reserved		
	3502	Reserved		
	3503	Reserved		
1B6	3504	aio0-3 input selection load 1	00: aio0 01: aio1 10: aio2 11: aio3	
	3505			

GreenPAK Programmable Mixed-Signal Matrix with Asynchronous State Machine and Dual Supply

Table 56: Register Map (Continued)

Address		Signal Function	Register Bit Definition
Byte	Register Bit		
1B6	3506	ACMP4_F Vref selection load 1	"F1 input selection load 1" bit = 0: Matrix input select: 000000: Matrix in0; ~ 111111: Matrix in63 "F1 input selection load 1" bit = 1: ACMP Vref select: 000000: 32 mV ~ 111110: 2.016 V/step = 32 mV; 111111: External Vref
	3507		
	3508		
	3509		
	3510		
	3511		
1B7	3512	aio0-3 input selection load 2	00: aio0 01: aio1 10: aio2 11: aio3
	3513		
	3514	ACMP4_F Vref selection load 2	"F1 input selection load 1" bit = 0: Matrix input select: 000000: Matrix in0; ~ 111111: Matrix in63 "F1 input selection load 1" bit = 1: ACMP Vref select: 000000: 32 mV ~ 111110: 2.016 V/step = 32 mV; 111111: External Vref
	3515		
	3516		
	3517		
	3518		
3519			
1B8	3520	aio4-7 input selection load 3	00: aio4 01: aio5 10: aio6 11: aio7
	3521		
	3522	ACMP4_F Vref selection load 3	"F1 input selection load 1" bit = 0: Matrix input select: 000000: Matrix in0; ~ 111111: Matrix in63 "F1 input selection load 1" bit = 1: ACMP Vref select: 000000: 32 mV ~ 111110: 2.016 V/step = 32 mV; 111111: External Vref
	3523		
	3524		
	3525		
	3526		
	3527		
1B9	3528	aio4-7 input selection load 4	00: aio4 01: aio5 10: aio6 11: aio7
	3529		
	3530	ACMP4_F Vref selection load 4	"F1 input selection load 1" bit = 0: Matrix input select: 000000: Matrix in0; ~ 111111: Matrix in63 "F1 input selection load 1" bit = 1: ACMP Vref select: 000000: 32 mV ~ 111110: 2.016 V/step = 32 mV; 111111: External VRE
	3531		
	3532		
	3533		
	3534		
3535			
1BA	3536	F1 input selection load 1	0: from matrix 1: from ACMP4_F
	3537	F1 input selection load 2	0: from matrix 1: from ACMP4_F
	3538	F1 input selection load 3	0: from matrix 1: from ACMP4_F
	3539	F1 input selection load 4	0: from matrix 1: from ACMP4_F
	3540	Reserved	

GreenPAK Programmable Mixed-Signal Matrix with Asynchronous State Machine and Dual Supply

Table 56: Register Map (Continued)

Address		Signal Function	Register Bit Definition
Byte	Register Bit		
1BA	3541	delay clock source selection	000: OSC2 001: OSC2/4 010: OSC1 011: OSC1/8 100: OSC1/64 101: OSC0 110: OSC0/8 111: OSC0/64
	3542		
	3543		
1BB	3544	F1 delay data	Data[7:0]
	3545		
	3546		
	3547		
	3548		
	3549		
	3550		
1BC	3551	F1 CMD1 selection	0000:load1;0001:load2;0010:load3;0011:load4;0100:and;0101:or;0110:xor;0111:inv;1000:push0;1001:pop;1010:delay;1011:delay with loop;1100:out1;1101:out2;1110:out3; 1111:end.
	3552		
	3553		
	3554	F1 CMD2 selection	0000:load1;0001:load2;0010:load3;0011:load4;0100:and;0101:or;0110:xor;0111:inv;1000:push0;1001:pop;1010:delay;1011:delay with loop;1100:out1;1101:out2;1110:out3; 1111:end.
	3555		
	3556		
	3557		
3558	F1 CMD3 selection	0000:load1;0001:load2;0010:load3;0011:load4;0100:and;0101:or;0110:xor;0111:inv;1000:push0;1001:pop;1010:delay;1011:delay with loop;1100:out1;1101:out2;1110:out3; 1111:end.	
3559			
1BD	3560	F1 CMD4 selection	0000:load1;0001:load2;0010:load3;0011:load4;0100:and;0101:or;0110:xor;0111:inv;1000:push0;1001:pop;1010:delay;1011:delay with loop;1100:out1;1101:out2;1110:out3; 1111:end.
	3561		
	3562		
	3563	F1 CMD5 selection	0000:load1;0001:load2;0010:load3;0011:load4;0100:and;0101:or;0110:xor;0111:inv;1000:push0;1001:pop;1010:delay;1011:delay with loop;1100:out1;1101:out2;1110:out3; 1111:end.
	3564		
	3565		
	3566		
3567	F1 CMD6 selection	0000:load1;0001:load2;0010:load3;0011:load4;0100:and;0101:or;0110:xor;0111:inv;1000:push0;1001:pop;1010:delay;1011:delay with loop;1100:out1;1101:out2;1110:out3; 1111:end.	
3568			
1BE	3569	F1 CMD6 selection	0000:load1;0001:load2;0010:load3;0011:load4;0100:and;0101:or;0110:xor;0111:inv;1000:push0;1001:pop;1010:delay;1011:delay with loop;1100:out1;1101:out2;1110:out3; 1111:end.
	3570		
	3571		
	3572	F1 CMD7 selection	0000:load1;0001:load2;0010:load3;0011:load4;0100:and;0101:or;0110:xor;0111:inv;1000:push0;1001:pop;1010:delay;1011:delay with loop;1100:out1;1101:out2;1110:out3; 1111:end.
	3573		
	3574		
	3575		

GreenPAK Programmable Mixed-Signal Matrix with Asynchronous State Machine and Dual Supply

Table 56: Register Map (Continued)

Address		Signal Function	Register Bit Definition
Byte	Register Bit		
1BF	3576	F1 CMD7 selection	0000:load1;0001:load2;0010:load3;0011:load4;0100:and;0101:or;0110:xor;0111:inv;1000:push0;1001:pop;1010:delay;1011:delay with loop;1100:out1;1101:out2;1110:out3; 1111:end.
	3577		
	3578		
	3579		
1BF	3580	F1 CMD8 selection	0000:load1;0001:load2;0010:load3;0011:load4;0100:and;0101:or;0110:xor;0111:inv;1000:push0;1001:pop;1010:delay;1011:delay with loop;1100:out1;1101:out2;1110:out3; 1111:end.
	3581		
	3582		
	3583		
1C0	3584	F1 CMD9 selection	0000:load1;0001:load2;0010:load3;0011:load4;0100:and;0101:or;0110:xor;0111:inv;1000:push0;1001:pop;1010:delay;1011:delay with loop;1100:out1;1101:out2;1110:out3; 1111:end.
	3585		
	3586		
	3587		
	3588	F1 CMD10 selection	0000:load1;0001:load2;0010:load3;0011:load4;0100:and;0101:or;0110:xor;0111:inv;1000:push0;1001:pop;1010:delay;1011:delay with loop;1100:out1;1101:out2;1110:out3; 1111:end.
	3589		
	3590		
3591			
1C1	3592	F1 CMD11 selection	0000:load1;0001:load2;0010:load3;0011:load4;0100:and;0101:or;0110:xor;0111:inv;1000:push0;1001:pop;1010:delay;1011:delay with loop;1100:out1;1101:out2;1110:out3; 1111:end.
	3593		
	3594		
	3595		
	3596	F1 CMD12 selection	0000:load1;0001:load2;0010:load3;0011:load4;0100:and;0101:or;0110:xor;0111:inv;1000:push0;1001:pop;1010:delay;1011:delay with loop;1100:out1;1101:out2;1110:out3; 1111:end.
	3597		
	3598		
	3599		
1C2	3600	loop with delay to location selection	0000:CMD1;0001:CMD2;0010:CMD3;0011:CMD4;0100:CMD5;0101:CMD6.or;0110:CMD7;0111:CMD8;1000:CMD9;1001:CMD10;1010:CMD11;1011:CMD12
	3601		
	3602		
	3603		
	3604	output mux1 initial state setting	00: keep 01: 0 10: 1 11: none
	3605		
	3606	output mux2 initial state setting	00: keep 01: 0 10: 1 11: none
	3607		

GreenPAK Programmable Mixed-Signal Matrix with Asynchronous State Machine and Dual Supply

Table 56: Register Map (Continued)

Address		Signal Function	Register Bit Definition
Byte	Register Bit		
1C3	3608	output mux3 initial state setting	00: keep 01: 0 10: 1 11: none
	3609		
	3610	interrupt reset stack memory enable	0: no reset stack memory 1: reset stack memory
	3611	Reserved	
	3612	Reserved	
	3613	Reserved	
	3614	Reserved	
1C3	3615	Reserved	
1C4	3616	aio0-3 input selection load 1	00: aio0 01: aio1 10: aio2 11: aio3
	3617		
	3618	ACMP4_F Vref selection load 1	"F1 input selection load 1" bit = 0: Matrix input select: 000000: Matrix in0; ~ 111111: Matrix in63 "F1 input selection load 1" bit = 1: ACMP Vref select: 000000: 32 mV ~ 111110: 2.016 V/step = 32 mV; 111111: External Vref
	3619		
	3620		
	3621		
	3622		
3623			
1C5	3624	aio0-3 input selection load 2	00: aio0 01: aio1 10: aio2 11: aio3
	3625		
	3626	ACMP4_F Vref selection load 2	"F1 input selection load 1" bit = 0: Matrix input select: 000000: Matrix in0; ~ 111111: Matrix in63 "F1 input selection load 1" bit = 1: ACMP Vref select: 000000: 32 mV ~ 111110: 2.016 V/step = 32 mV; 111111: External Vref
	3627		
	3628		
	3629		
	3630		
3631			
1C6	3632	aio4-7 input selection load 3	00: aio4 01: aio5 10: aio6 11: aio7
	3633		
	3634	ACMP4_F Vref selection load 3	"F1 input selection load 1" bit = 0: Matrix input select: 000000: Matrix in0; ~ 111111: Matrix in63 "F1 input selection load 1" bit = 1: ACMP Vref select: 000000: 32 mV ~ 111110: 2.016 V/step = 32 mV; 111111: External Vref
	3635		
	3636		
	3637		
	3638		
3639			

GreenPAK Programmable Mixed-Signal Matrix with Asynchronous State Machine and Dual Supply

Table 56: Register Map (Continued)

Address		Signal Function	Register Bit Definition
Byte	Register Bit		
1C7	3640	aio4-7 input selection load 4	00: aio4 01: aio5 10: aio6 11: aio7
	3641		
	3642	ACMP4_F Vref selection load 4	"F1 input selection load 1" bit = 0: Matrix input select: 000000: Matrix in0; ~ 111111: Matrix in63 "F1 input selection load 1" bit = 1: ACMP Vref select: 000000: 32 mV ~ 111110: 2.016 V/step = 32 mV; 111111: External Vref
	3643		
	3644		
	3645		
	3646		
3647			
1C8	3648	F1 input selection load 1	0: from matrix 1: from ACMP4_F
	3649	F1 input selection load 2	0: from matrix 1: from ACMP4_F
1C8	3650	F1 input selection load 3	0: from matrix 1: from ACMP4_F
	3651	F1 input selection load 4	0: from matrix 1: from ACMP4_F
	3652	Reserved	
	3653	delay clock source selection	000: OSC2 001: OSC2/4 010: OSC1 011: OSC1/8 100: OSC1/64 101: OSC0 110: OSC0/8 111: OSC0/64
	3654		
3655			
1C9	3656	F1 delay data	Data[7:0]
	3657		
	3658		
	3659		
	3660		
	3661		
	3662		
3663			
1CA	3664	F1 CMD1 selection	0000:load1;0001:load2;0010:load3;0011:load4;0100:and;0101:or;0110:xor;0111:inv;1000:push0;1001:pop;1010:delay;1011:delay with loop;1100:out1;1101:out2;1110:out3; 1111:end.
	3665		
	3666		
	3667	F1 CMD2 selection	0000:load1;0001:load2;0010:load3;0011:load4;0100:and;0101:or;0110:xor;0111:inv;1000:push0;1001:pop;1010:delay;1011:delay with loop;1100:out1;1101:out2;1110:out3; 1111:end.
	3668		
	3669		
	3670		
3671			

GreenPAK Programmable Mixed-Signal Matrix with Asynchronous State Machine and Dual Supply

Table 56: Register Map (Continued)

Address		Signal Function	Register Bit Definition
Byte	Register Bit		
1CB	3672	F1 CMD3 selection	0000:load1;0001:load2;0010:load3;0011:load4;0100:and;0101:or;0110:xor;0111:inv;1000:push0;1001:pop;1010:delay;1011:delay with loop;1100:out1;1101:out2;1110:out3; 1111:end.
	3673		
	3674		
	3675		
	3676	F1 CMD4 selection	
	3677		
	3678		
	3679		
1CC	3680	F1 CMD5 selection	
	3681		
	3682		
	3683		
1CC	3684	F1 CMD6 selection	
	3685		
	3686		
	3687		
1CD	3688	F1 CMD7 selection	0000:load1;0001:load2;0010:load3;0011:load4;0100:and;0101:or;0110:xor;0111:inv;1000:push0;1001:pop;1010:delay;1011:delay with loop;1100:out1;1101:out2;1110:out3; 1111:end.
	3689		
	3690		
	3691		
	3692	F1 CMD8 selection	
	3693		
	3694		
	3695		
1CE	3696	F1 CMD9 selection	0000:load1;0001:load2;0010:load3;0011:load4;0100:and;0101:or;0110:xor;0111:inv;1000:push0;1001:pop;1010:delay;1011:delay with loop;1100:out1;1101:out2;1110:out3; 1111:end.
	3697		
	3698		
	3699		
	3700	F1 CMD10 selection	
	3701		
	3702		
	3703		
1CF	3704	F1 CMD11 selection	0000:load1;0001:load2;0010:load3;0011:load4;0100:and;0101:or;0110:xor;0111:inv;1000:push0;1001:pop;1010:delay;1011:delay with loop;1100:out1;1101:out2;1110:out3; 1111:end.
	3705		
	3706		
	3707		
	3708	F1 CMD12 selection	
	3709		
	3710		
	3711		

GreenPAK Programmable Mixed-Signal Matrix with Asynchronous State Machine and Dual Supply
Table 56: Register Map (Continued)

Address		Signal Function	Register Bit Definition
Byte	Register Bit		
1D0	3712	loop with delay to location selection	0000: CMD1; 0001: CMD2; 0010: CMD3; 0011: CMD4; 0100: CMD5; 0101: CMD6 or; 0110: CMD7; 0111: CMD8; 1000: CMD9; 1001: CMD10; 1010: CMD11; 1011: CMD12
	3713		
	3714		
	3715		
	3716	output mux1 initial state setting	00: keep 01: 0 10: 1 11: none
	3717		
	3718	output mux2 initial state setting	00: keep 01: 0 10: 1 11: none
	3719		
1D1	3720	output mux3 initial state setting	00: keep 01: 0 10: 1 11: none
	3721		
1D1	3722	interrupt reset stack memory enable	0: no reset stack memory 1: reset stack memory
	3723	Reserved	
	3724	Reserved	
	3725	Reserved	
	3726	Reserved	
	3727	Reserved	

GreenPAK Programmable Mixed-Signal Matrix with Asynchronous State Machine and Dual Supply

Table 56: Register Map (Continued)

Address		Signal Function	Register Bit Definition
Byte	Register Bit		
1D2	3728	F1 state0 setting selection	000: none
	3729		001: setting 0
	3730		010: setting 1
	3731	F1 state 1 setting selection	011: setting 2
	3732		100: setting 3
	3733		101: none
3734	F1 state 2 setting selection	110: none	
3735		111: none	
1D3	3736	F1 state 3 setting selection	000: none
	3737		001: setting 0
	3738		010: setting 1
	3739	F1 state 4 setting selection	011: setting 2
	3740		100: setting 3
	3741		101: none
3742		110: none	
			111: none

GreenPAK Programmable Mixed-Signal Matrix with Asynchronous State Machine and Dual Supply
Table 56: Register Map (Continued)

Address		Signal Function	Register Bit Definition	
Byte	Register Bit			
1D4	3743	F1 state 5 setting selection	000: none	
	3744		001: setting 0	
	3745		010: setting 1	
				011: setting 2
				100: setting 3
				101: none
				110: none
				111: none
			F1 state 6 setting selection	000: none
	3746			001: setting 0
3747		010: setting 1		
			011: setting 2	
			100: setting 3	
			101: none	
			110: none	
			111: none	
		F1 state 7 setting selection	000: none	
3749			001: setting 0	
3750			010: setting 1	
			011: setting 2	
			100: setting 3	
			101: none	
			110: none	
			111: none	
	3751			

GreenPAK Programmable Mixed-Signal Matrix with Asynchronous State Machine and Dual Supply

Table 56: Register Map (Continued)

Address		Signal Function	Register Bit Definition
Byte	Register Bit		
1D5	3752	F1 state 8 setting selection	000: none
	3753		001: setting 0
	3754		010: setting 1
	3755	F1 state 9 setting selection	011: setting 2
	3756		100: setting 3
	3757		101: none
1D6	3758	F1 state 10 setting selection	110: none
	3759		111: none
	3760	F1 state 11 setting selection	000: none
	3761		001: setting 0
3762	010: setting 1		
1D6	3763	F1 state 11 setting selection	011: setting 2
	3764		100: setting 3
	3765		101: none
	3766	110: none	
1D6	3767	111: none.	1: interrupt active
	3768	Reserved	
	3769	Reserved	
	3770	register interrupt	
1D7	3771	Reserved	
	3772	Matrix Input 0	GND
	3773	Matrix Input 1	GPIO0 Digital Input
	3774	Matrix Input 2	GPIO1 Digital Input
	3775	Matrix Input 3	GPIO2 Digital Input
	3776	Matrix Input 4	GPIO Digital Input
	3777	Matrix Input 5	GPIO Digital Input
	3778	Matrix Input 6	GPIO3 Digital Input
3779	Matrix Input 7	GPIO4 Digital Input	

GreenPAK Programmable Mixed-Signal Matrix with Asynchronous State Machine and Dual Supply

Table 56: Register Map (Continued)

Address		Signal Function	Register Bit Definition
Byte	Register Bit		
1D8	3776	Matrix Input 8	LUT2_0/DFF0 Output
	3777	Matrix Input 9	LUT2_1/PGen Output
	3778	Matrix Input 10	LUT3_0/DFF1 Output
	3779	Matrix Input 11	LUT3_1/DFF2 Output
	3780	Matrix Input 12	LUT3_2/DFF3 Output
	3781	Matrix Input 13	LUT3_3/DFF4 Output
	3782	Matrix Input 14	LUT3_4/CNT_DLY1(8bit) Output
	3783	Matrix Input 15	LUT3_5/CNT_DLY2(8bit) Output
1D9	3784	Matrix Input 16	LUT3_6/CNT_DLY3(8bit) Output
	3785	Matrix Input 17	LUT3_7/CNT_DLY4(8bit) Output
	3786	Matrix Input 18	LUT4_0/CNT_DLY0(16bit) Output
	3787	Matrix Input 19	LUT3_8/Pipe Delay Output0/Ripple CNT Output0
	3788	Matrix Input 20	Pipe Delay Output1/Ripple CNT Output1
	3789	Matrix Input 21	Internal OSC1 2.048 MHz Output
	3790	Matrix Input 22	Internal OSC0 2.048 kHz Output
	3791	Matrix Input 23	Internal OSC2 25 MHz Output
1DA	3792	Matrix Input 24	Filter0/Edge Detect0 Output/Ripple CNT Output2
	3793	Matrix Input 25	Programmable Delay with Edge Detector Output
	3794	Matrix Input 26	F(1) Function Output0
	3795	Matrix Input 27	F(1) Function Output1
	3796	Matrix Input 28	F(1) Function Output2
	3797	Matrix Input 29	DM0_0 Block Output0
	3798	Matrix Input 30	DM0_0 Block Output1
	3799	Matrix Input 31	DM0_0 Block Output2
1DB	3800	Matrix Input 32	GPI2/SDA Digital Input or I ² C_virtual_0 Input
	3801	Matrix Input 33	GPI3/SCL Digital Input or I ² C_virtual_1 Input
	3802	Matrix Input 34	I ² C_virtual_2 Input
	3803	Matrix Input 35	I ² C_virtual_3 Input
1DB	3804	Matrix Input 36	I ² C_virtual_4 Input
	3805	Matrix Input 37	I ² C_virtual_5 Input
	3806	Matrix Input 38	I ² C_virtual_6 Input
	3807	Matrix Input 39	I ² C_virtual_7 Input
1DC	3808	Matrix Input 40	DM0_1 Macrocell Output0
	3809	Matrix Input 41	DM0_1 Macrocell Output1
	3810	Matrix Input 42	DM0_1 Macrocell Output2
	3811	Matrix Input 43	ASM Connection Matrix Output RAM 0
	3812	Matrix Input 44	ASM Connection Matrix Output RAM 1
	3813	Matrix Input 45	ASM Connection Matrix Output RAM 2
	3814	Matrix Input 46	ASM Connection Matrix Output RAM 0
	3815	Matrix Input 47	GPIO5 Digital Input

GreenPAK Programmable Mixed-Signal Matrix with Asynchronous State Machine and Dual Supply

Table 56: Register Map (Continued)

Address		Signal Function	Register Bit Definition
Byte	Register Bit		
1DD	3816	Matrix Input 48	GPIO6 Digital Input
	3817	Matrix Input 49	GPIO7 Digital Input
	3818	Matrix Input 50	GPIO8 Digital Input
	3819	Matrix Input 51	GPI4 Digital Input
	3820	Matrix Input 52	GPI5 Digital Input
	3821	Matrix Input 53	GPI6 Digital Input
	3822	Matrix Input 54	GPI7 Digital Input
	3823	Matrix Input 55	GPIO9 Digital Input
1DE	3824	Matrix Input 56	ACMP0H Output
	3825	Matrix Input 57	ACMP1H Output
	3826	Matrix Input 58	ACMP2L Output
	3827	Matrix Input 59	ACMP3L output
	3828	Matrix Input 60	GPIO10 Digital Input
	3829	Matrix Input 61	GPIO11 Digital Input
	3830	Matrix Input 62	nRST_core (POR) as matrix input
	3831	Matrix Input 63	V _{DD}
1DF	3832	CNT0 (16bits) Counted Value	
	3833		
	3834		
	3835		
	3836		
	3837		
	3838		
	3839		
1E0	3840	CNT0 (16bits) Counted Value	
	3841		
	3842		
	3843		
	3844		
	3845		
	3846		
	3847		
1E1	3848	CNT2 (8bits) Counted Value	
	3849		
	3850		
	3851		
	3852		
	3853		
	3854		
	3855		

GreenPAK Programmable Mixed-Signal Matrix with Asynchronous State Machine and Dual Supply

Table 56: Register Map (Continued)

Address		Signal Function	Register Bit Definition
Byte	Register Bit		
1E2	3856	CNT4 (8bits) Counted Value	
	3857		
	3858		
	3859		
	3860		
	3861		
	3862		
	3863		
1E3	3864	ASM state read back	
	3865		
	3866		
	3867		
	3868		
	3869		
	3870		
	3871		
1E4	3872		
	3873		
	3874		
	3875		
	3876		
	3877		
	3878		
	3879		
1E5	3880	GPIO4 I ² C output expander data	
	3881	GPIO4 I ² C output expander select	0: GPIO4 output from matrix 1: GPIO4 output is register
	3882	GPIO5 I ² C output expander data	
	3883	GPIO5 I ² C output expander select	0: GPIO5 output from matrix 1: GPIO5 output is register
	3884	GPIO6 I ² C output expander data	
	3885	GPIO6 I ² C output expander select	0: GPIO6 output from matrix 1: GPIO6 output is register
	3886	GPIO7 I ² C output expander data	
	3887	GPIO7 I ² C output expander select	0: GPIO7 output from matrix 1: GPIO7 output is register

GreenPAK Programmable Mixed-Signal Matrix with Asynchronous State Machine and Dual Supply

Table 56: Register Map (Continued)

Address		Signal Function	Register Bit Definition
Byte	Register Bit		
1E6	3888	ACMP0_H Gain divider	ACMP gain divider select: 00: 1x 01: 0.5x 10: 0.33x 11: Reserved
	3889		
	3890	ACMP0_H Vref	ACMP Vref select: 000000: 32 mV ~ 111110: 2.016 V/step = 32 mV 111111: External Vref
	3891		
	3892		
	3893		
	3894		
3895			
1E7	3896	ACMP1_H Gain divider	ACMP gain divider select: 00: 1x 01: 0.5x 10: 0.33x 11: Reserved
	3897		
1E7	3898	ACMP1_H Vref	ACMP Vref select: 000000: 32 mV ~ 111110: 2.016 V/step = 32 mV 111111: External Vref
	3899		
	3900		
	3901		
	3902		
1E8	3904	ACMP2_L Gain divider	ACMP gain divider select: 00: 1x 01: 0.5x 10: 0.33x 11: Reserved
	3905		
	3906	ACMP2_L Vref	ACMP Vref select: 000000: 32 mV ~ 111110: 2.016 V/step = 32 mV 111111: External Vref
	3907		
	3908		
	3909		
	3910		
3911			
1E9	3912	ACMP3_L Gain divider	ACMP gain divider select: 00: 1x 01: 0.5x 10: 0.33x 11: Reserved
	3913		
	3914	ACMP3_L Vref	ACMP Vref select: 000000: 32 mV ~ 111110: 2.016 V/step = 32 mV 111111: External Vref
	3915		
	3916		
	3917		
	3918		
3919			

GreenPAK Programmable Mixed-Signal Matrix with Asynchronous State Machine and Dual Supply

Table 56: Register Map (Continued)

Address		Signal Function	Register Bit Definition
Byte	Register Bit		
1EA	3920	REG_LUT4_0_D0[15:0]	Data[15:0]
	3921		
	3922		
	3923		
	3924		
	3925		
	3926		
	3927		
1EB	3928		
	3929		
	3930		
	3931		
	3932		
	3933		
	3934		
	3935		
1EC	3936	REG_LUT3_4_D1[7:0]	Data[7:0]
	3937		
	3938		
	3939		
	3940		
	3941		
	3942		
	3943		
1ED	3944	REG_LUT3_5_D2[7:0]	Data[7:0]
	3945		
	3946		
	3947		
	3948		
	3949		
	3950		
	3951		
1EE	3952	REG_LUT3_6_D3[7:0]	Data[7:0]
	3953		
	3954		
	3955		
	3956		
	3957		
	3958		
	3959		

GreenPAK Programmable Mixed-Signal Matrix with Asynchronous State Machine and Dual Supply

Table 56: Register Map (Continued)

Address		Signal Function	Register Bit Definition
Byte	Register Bit		
1EF	3960	REG_LUT3_7_D4[7:0]	Data[7:0]
	3961		
	3962		
	3963		
	3964		
	3965		
	3966		
	3967		
1F0	3968	Reserved	
	3969	Reserved	
	3970	Reserved	
	3971	Reserved	
	3972	Reserved	
	3973	Reserved	
	3974	Reserved	
	3975	Reserved	
1F1	3976	Reserved	
	3977	Reserved	
	3978	Reserved	
	3979	Reserved	
	3980	Reserved	
	3981	Reserved	
	3982	Reserved	
	3983	Reserved	
1F2	3984	Reserved	
	3985	Reserved	
	3986	Reserved	
	3987	Reserved	
	3988	Reserved	
	3989	Reserved	
	3990	Reserved	
	3991	Reserved	
1F3	3992	Reserved	
	3993	Reserved	
	3994	Reserved	
	3995	Reserved	
	3996	Reserved	
	3997	Reserved	
	3998	Reserved	
	3999	Reserved	

GreenPAK Programmable Mixed-Signal Matrix with Asynchronous State Machine and Dual Supply

Table 56: Register Map (Continued)

Address		Signal Function	Register Bit Definition
Byte	Register Bit		
1F4	4000	Reserved	
	4001	Reserved	
	4002	Reserved	
	4003	Reserved	
	4004	Reserved	
	4005	Reserved	
	4006	Reserved	
	4007	Reserved	
1F5	4008	Reserved	
	4009	Reserved	
	4010	Reserved	
	4011	Reserved	
	4012	Reserved	
	4013	Reserved	
	4014	Reserved	
	4015	Reserved	
1F6	4016	Reserved	
	4017	Reserved	
	4018	Reserved	
	4019	Reserved	
	4020	Reserved	
	4021	Reserved	
	4022	Reserved	
	4023	Reserved	
1F7	4024	Reserved	
	4025		
	4026		
	4027		
	4028		
	4029		
	4030		
	4031		
1F8	4032	Reserved	
	4033	Reserved	
	4034	Reserved	
	4035		
	4036	Reserved	
	4037		
	4038		
	4039		

GreenPAK Programmable Mixed-Signal Matrix with Asynchronous State Machine and Dual Supply

Table 56: Register Map (Continued)

Address		Signal Function	Register Bit Definition
Byte	Register Bit		
1F9	4040	8-bit Pattern ID Byte 0 (From NVM): ID[23:16]	
	4041		
	4042		
	4043		
	4044		
	4045		
	4046		
	4047		
1FA	4048	Reserved	
	4049		
	4050		
	4051		
	4052		
	4053		
	4054		
	4055		
1FB	4056	Reserved	
	4057		
	4058		
	4059		
	4060		
	4061		
	4062		
	4063		
1FC	4064	I ² C reset bit with reloading NVM into Data register (soft reset)	0: Keep existing condition 1: Reset execution
	4065	IO Latching Enable During I ² C Write Interface	0: Disable 1: Enable
	4066	Reserved	
	4067	protect mode enable	0: Disable 1: Enable
	4068	Reserved	
	4069	register protection mode bit 0	000: all open read/write (mode 0); 001: partly lock read (mode 1); 010: partly lock read2 (mode 2); 011: partly lock read2/write (mode 3); 100: all lock read (mode 4); 101: all lock write (mode 5); 110: all lock read/write (mode 6).
	4070	register protection mode bit 1	
	4071	register protection mode bit 2	

GreenPAK Programmable Mixed-Signal Matrix with Asynchronous State Machine and Dual Supply

Table 56: Register Map (Continued)

Address		Signal Function	Register Bit Definition
Byte	Register Bit		
1FD	4072	I ² C write mask bits	1: mask 0: overwrite
	4073		
	4074		
	4075		
	4076		
	4077		
	4078		
	4079		
1FE	4080	I ² C slave address	
	4081		
	4082		
	4083		
	4084	I ² C operation disable bit	0: I ² C operation enable; matrix in 34(35) select I ² C_virtual_0(1) Input 1: I ² C operation disable; matrix in 34(35) select GPI2(3) digital input
	4085	Reserved	
	4086	Reserved	
	4087	slave address selection	0: from Register 1: from Pin
1FF	4088	Reserved	
	4089		
	4090		
	4091		
	4092		
	4093		
	4094		
	4095		

22 Package Top Marking System Definition

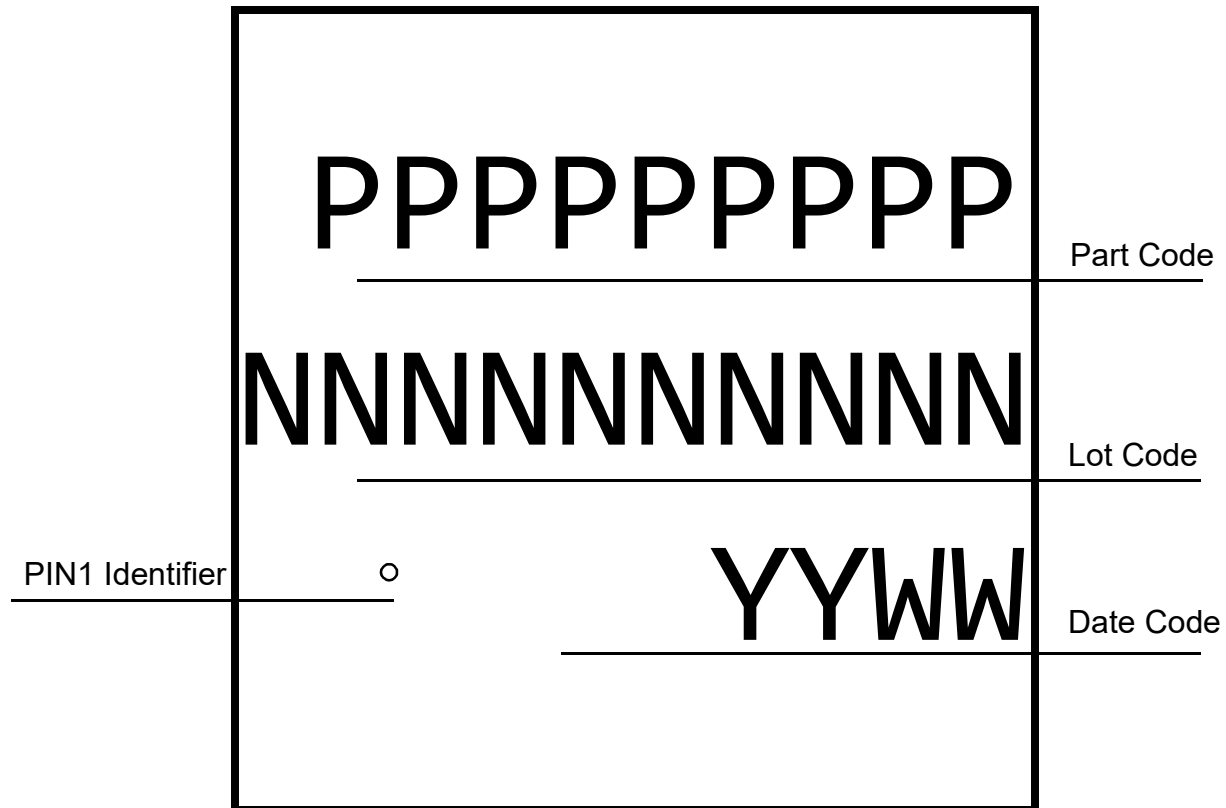

23 Package Information

STQFN 32L 4 mm x 4 mm 0.4P Package
JEDEC MO-220, Variation WECE

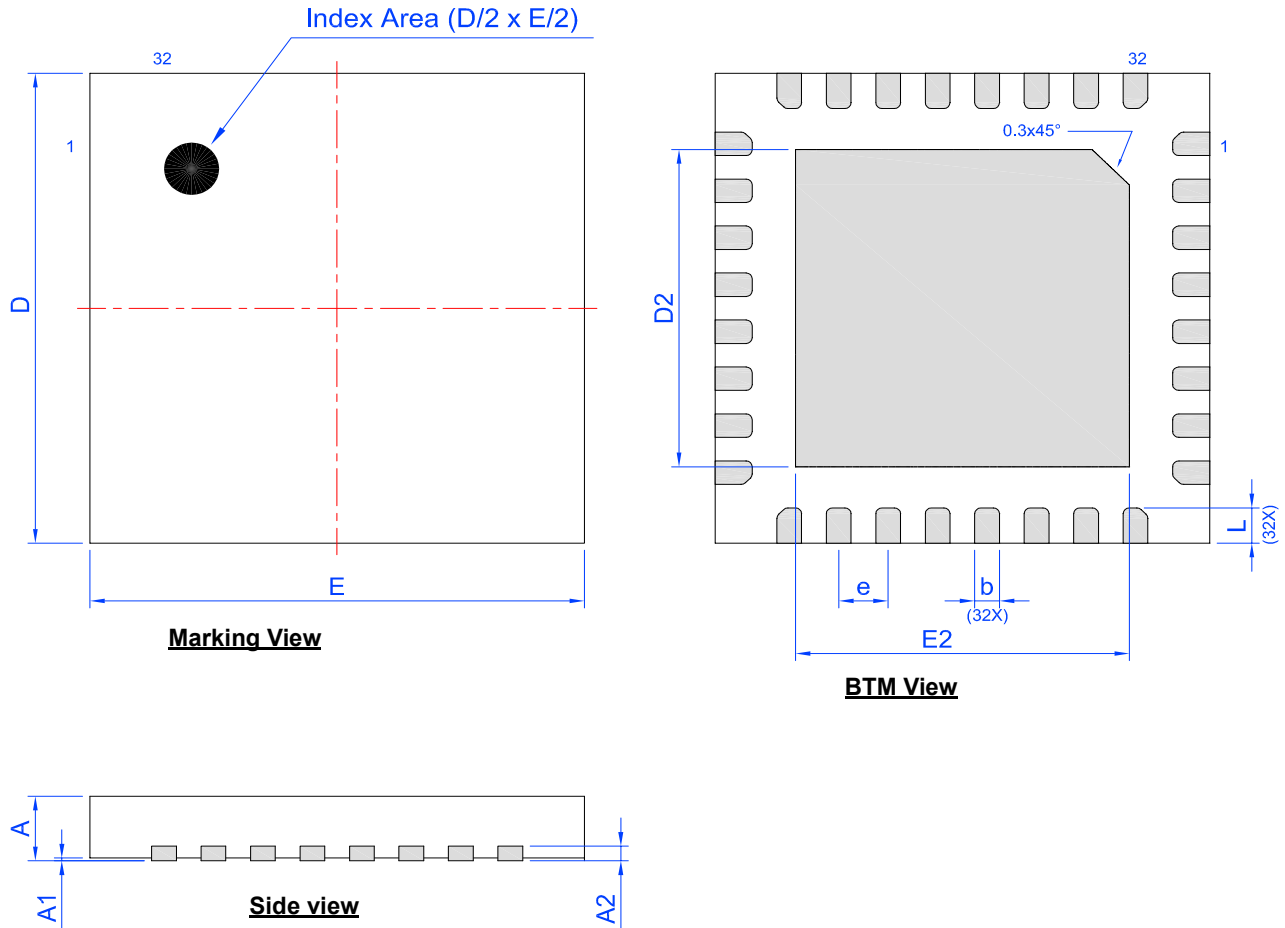

Unit: mm

Symbol	Min.	Nom.	Max.	Symbol	Min.	Nom.	Max.
A	0.500	0.550	0.600	D	3.950	4.000	4.050
A1	0.00	-	0.050	E	3.950	4.000	4.050
A2	0.150 REF			D2	2.650	2.700	2.750
b	0.150	0.200	0.250	E2	2.650	0.270	2.750
e	0.400 BSC			L	0.250	0.300	0.350

GreenPAK Programmable Mixed-Signal Matrix with Asynchronous State Machine and Dual Supply

23.1 STQFN HANDLING

Be sure to handle STQFN package only in a clean, ESD-safe environment. Tweezers or vacuum pick-up tools are suitable for handling. Do not handle STQFN package with fingers as this can contaminate the package pins and interface with solder reflow.

23.2 SOLDERING INFORMATION

Please see IPC/JEDEC J-STD-020: latest revision for reflow profile based on package volume of 3.85 mm³ (nominal). More information can be found at www.jedec.org.

24 Ordering Information

Part Number	Type
SLG46880V	32-Pin STQFN
SLG46880VTR	32-Pin STQFN - Tape and Reel (5k units)
SLG46881V	32-Pin STQFN
SLG46881VTR	32-Pin STQFN - Tape and Reel (5k units)

24.1 TAPE AND REEL SPECIFICATIONS

Package Type	# of Pins	Nominal Package Size (mm)	Max Units		Reel & Hub Size (mm)	Leader (min)		Trailer (min)		Tape Width (mm)	Part Pitch (mm)
			per Reel	per Box		Pockets	Length (mm)	Pockets	Length (mm)		
STQFN 32L 4 mm x4 mm 0.4P Green	32	4 x 4 x 0.55	5,000	10,000	330/100	42	336	42	336	12	8

24.2 CARRIER TAPE DRAWING AND DIMENSIONS

Package Type	PocketBTM Length (mm)	PocketBTM Width (mm)	Pocket Depth (mm)	Index Hole Pitch (mm)	Pocket Pitch (mm)	Index Hole Diameter (mm)	Index Hole to Tape Edge (mm)	Index Hole to Pocket Center (mm)	Tape Width (mm)
	A0	B0	K0	P0	P1	D0	E	F	W
STQFN 32L 2 mm x3 mm 0.4P Green	4.25	4.25	0.75	4	8	1.5	1.75	5.5	12

GreenPAK Programmable Mixed-Signal Matrix with Asynchronous State Machine and Dual Supply

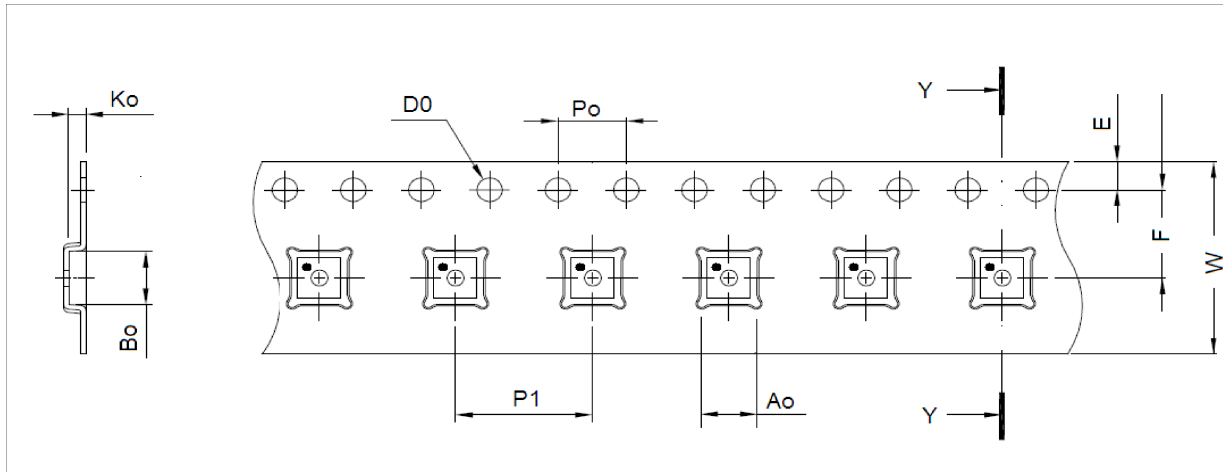

Refer to EIA-481 specification

25 Layout Guidelines

Units: μm

 Exposed Pad
(PKG face down)

 Recommended Land Pattern
(PKG face down)

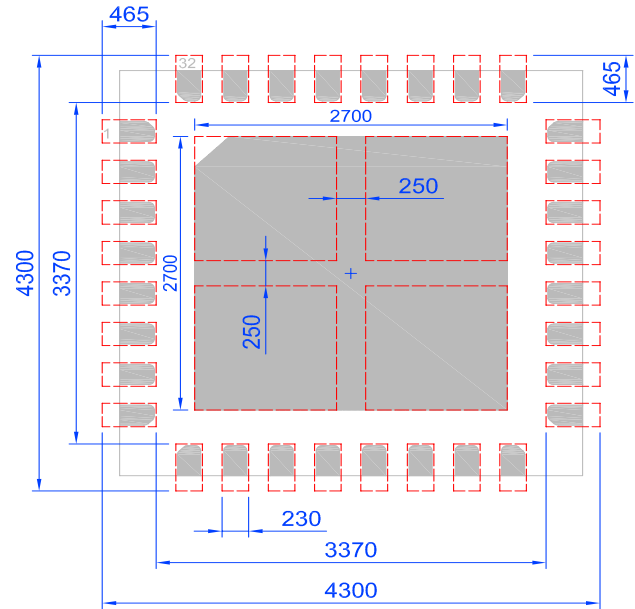
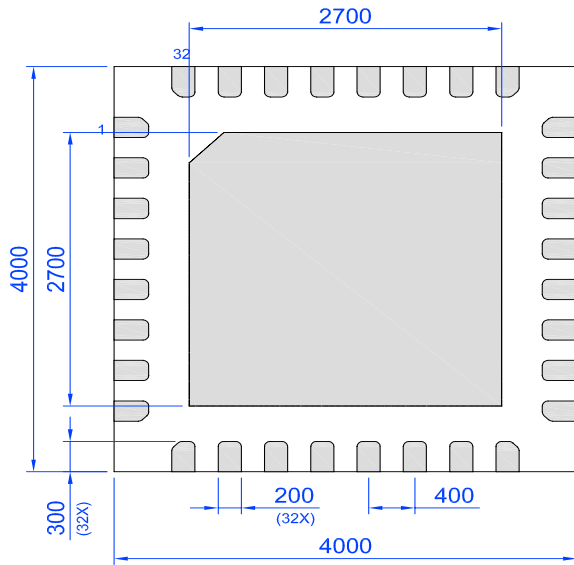

GreenPAK Programmable Mixed-Signal Matrix with Asynchronous State Machine and Dual Supply

Glossary**A**

ACK	Acknowledge bit
ACMP	Analog Comparator
ACMPH	Analog Comparator High Speed
ACMPL	Analog Comparator Low Power
ASM	Asynchronous State Machine

B

BG	Bandgap
----	---------

C

CLK	Clock
CMO	Connection matrix output
CNT	Counter

D

DFF	D Flip-Flop
DLY	Delay
DM	Dynamic Memory

E

EC	Electrical Characteristics
ERSE	Erase Enable
ERSR	Erase Register
ESD	Electrostatic discharge
EV	End Value

F

FSM	Finite State Machine
-----	----------------------

G

GPI	General Purpose Input
GPIO	General Purpose Input/Output
GPO	General Purpose Output

I

IN	Input
IO	Input/Output

L

LPF	Low Pass Filter
LSB	Least Significant Bit
LUT	Look Up Table
LV	Low Voltage

GreenPAK Programmable Mixed-Signal Matrix with Asynchronous State Machine and Dual Supply

LWD Loop with Delay

M

MSB Most Significant Bit
MTP Multiple-Time-Programmable
MUX Multiplexer

N

NPR Non-Volatile Memory Read/Write/Erase Protection
nRST Reset
NVM Non-Volatile Memory

O

OD Open-Drain
OE Output Enable
OSC Oscillator
OUT Output

P

PD Power-down
PGen Pattern Generator
POR Power-On Reset
PP Push-Pull
PRL Protect Lock Bit
PWR Power
P DLY Programmable Delay

R

RPR Register Read/Write Protection
RPRB Register Read/Write Protection Bit
RPRL Register Protection Read/Write/Erase Lock
R/W Read/Write

S

SCL I²C Clock Input
SDA I²C Data Input/Output
SLA Slave Address
SMT With Schmitt Trigger
SV nSET Value

T

TS Temperature Sensor

V

Vref Voltage Reference

GreenPAK Programmable Mixed-Signal Matrix with Asynchronous State Machine and Dual Supply**W**

WOSMT	Without Schmitt Trigger
WPB	Write Protect Bit
WPR	Write Protection Register
WPRE	Write Protect Enable
WS	Wake and Sleep Controller

GreenPAK Programmable Mixed-Signal Matrix with Asynchronous State Machine and Dual Supply

Revision History

Revision	Date	Description
3.11	11-Dec-2019	Corrected Reset Command Timing figure Updated PIN Block Diagrams Updated Typical Counter/Delay Offset Corrected EC of the I ² C Pins Table Fixed typos Corrected Edge Detection Mode Timing Diagram Corrected Delayed Edge Detection Mode Timing Diagram Updated subsection Reading Counter Data via I ² C
3.10	3-Jul-2019	Corrected registers [731:730], [737:736], [3831:3768], [4084]
3.9	4-Jun-2019	Updated Analog Temperature sensor section Updated according to Dialog's Writing Guideline Fixed typos Corrected Oscillators names Updated Ordering Information Changed I ² C Serial Communications Macrocell section structure
3.8	16-Apr-2019	Corrected 2-bit LUT1 or PGen Figure Updated registers [535], [3765:3764] Added new subsection Electrostatic Discharge Ratings Fixed typos
3.7	1-Mar-2019	Removed information about SCL and SDA Pins' Schmitt Trigger Corrected Deglitch Filter/Edge Detector Block Diagram Updated Analog Temperature Sensor Structure Diagram Corrected register definitions Fixed typos
3.6	4-Jan-2019	Added subsection f(1) Performance Added subsection IO Pins Performance Added ACMPs' hysteresis information Added additional information about V _{DD2} to IO Pins section Added table Typical Delay Estimated for F(1) Added graph for ACMP Input Current Source Updated Input Current Source Spec Added section ACMP Typical Performance Updated Analog Temperature Sensor Electrical Spec Added sections Oscillators Power-On Delay and Oscillators Accuracy Corrected Absolute Maximum Ratings Updated Typical Delay table Updated DM Block Diagrams Updated ACMP section Fixed typos
3.5	14-Sept-2018	Fixed typos Updated Analog Temperature Sensor Structure Diagram Updated Example of I ² C Byte Write Bit Masking
3.4	20-Aug-2018	Updated EC for SLG46881 Fixed typos
3.3	9-Aug-2018	Fixed typos
3.2	27-Jul-2018	Updated TS Structure Diagram Added STQFN Handling section Updated ACMP Electrical Spec Fixed formatting Updated R _{PULL} in Electrical Spec
3.1	30-Apr-2018	Updated TS Electrical Spec
3.0	18-Apr-2018	Final version

GreenPAK Programmable Mixed-Signal Matrix with Asynchronous State Machine and Dual Supply

Status Definitions

Revision	Datasheet Status	Product Status	Definition
1.<n>	Target	Development	This datasheet contains the design specifications for product development. Specifications may change in any manner without notice.
2.<n>	Preliminary	Qualification	This datasheet contains the specifications and preliminary characterization data for products in pre-production. Specifications may be changed at any time without notice in order to improve the design.
3.<n>	Final	Production	This datasheet contains the final specifications for products in volume production. The specifications may be changed at any time in order to improve the design, manufacturing and supply. Major specification changes are communicated via Customer Product Notifications. Datasheet changes are communicated via www.dialog-semiconductor.com .
4.<n>	Obsolete	Archived	This datasheet contains the specifications for discontinued products. The information is provided for reference only.

Disclaimer

Unless otherwise agreed in writing, the Dialog Semiconductor products (and any associated software) referred to in this document are not designed, authorized or warranted to be suitable for use in life support, life-critical or safety-critical systems or equipment, nor in applications where failure or malfunction of a Dialog Semiconductor product (or associated software) can reasonably be expected to result in personal injury, death or severe property or environmental damage. Dialog Semiconductor and its suppliers accept no liability for inclusion and/or use of Dialog Semiconductor products (and any associated software) in such equipment or applications and therefore such inclusion and/or use is at the customer's own risk.

Information in this document is believed to be accurate and reliable. However, Dialog Semiconductor does not give any representations or warranties, express or implied, as to the accuracy or completeness of such information. Dialog Semiconductor furthermore takes no responsibility whatsoever for the content in this document if provided by any information source outside of Dialog Semiconductor.

Dialog Semiconductor reserves the right to change without notice the information published in this document, including, without limitation, the specification and the design of the related semiconductor products, software and applications. Notwithstanding the foregoing, for any automotive grade version of the device, Dialog Semiconductor reserves the right to change the information published in this document, including, without limitation, the specification and the design of the related semiconductor products, software and applications, in accordance with its standard automotive change notification process.

Applications, software, and semiconductor products described in this document are for illustrative purposes only. Dialog Semiconductor makes no representation or warranty that such applications, software and semiconductor products will be suitable for the specified use without further testing or modification. Unless otherwise agreed in writing, such testing or modification is the sole responsibility of the customer and Dialog Semiconductor excludes all liability in this respect.

Nothing in this document may be construed as a license for customer to use the Dialog Semiconductor products, software and applications referred to in this document. Such license must be separately sought by customer with Dialog Semiconductor.

All use of Dialog Semiconductor products, software and applications referred to in this document are subject to Dialog Semiconductor's [Standard Terms and Conditions of Sale](http://www.dialog-semiconductor.com), available on the company website (www.dialog-semiconductor.com) unless otherwise stated.

Dialog, Dialog Semiconductor and the Dialog logo are trademarks of Dialog Semiconductor Plc or its subsidiaries. All other product or service names and marks are the property of their respective owners.

© 2019 Dialog Semiconductor. All rights reserved.

RoHS Compliance

Dialog Semiconductor's suppliers certify that its products are in compliance with the requirements of Directive 2011/65/EU of the European Parliament on the restriction of the use of certain hazardous substances in electrical and electronic equipment. RoHS certificates from our suppliers are available on request.

Contacting Dialog Semiconductor

United Kingdom (Headquarters)

Dialog Semiconductor (UK) LTD
Phone: +44 1793 757700

Germany

Dialog Semiconductor GmbH
Phone: +49 7021 805-0

The Netherlands

Dialog Semiconductor B.V.
Phone: +31 73 640 8822

Email:

enquiry@diasemi.com

North America

Dialog Semiconductor Inc.
Phone: +1 408 845 8500

Japan

Dialog Semiconductor K. K.
Phone: +81 3 5769 5100

Taiwan

Dialog Semiconductor Taiwan
Phone: +886 281 786 222

Web site:

www.dialog-semiconductor.com

Hong Kong

Dialog Semiconductor Hong Kong
Phone: +852 2607 4271

Korea

Dialog Semiconductor Korea
Phone: +82 2 3469 8200

China (Shenzhen)

Dialog Semiconductor China
Phone: +86 755 2981 3669

China (Shanghai)

Dialog Semiconductor China
Phone: +86 21 5424 9058