

High Performance AC/DC Primary-Side Rapid Charge™ PWM Controller Supporting XM-Comm Technology

1 Description

The iW1796 is a high performance AC/DC power supply controller for Rapid Charge applications that uses transformer communication (XM-Comm) technology to minimize external component count and simplify system design. The iW1796 can support high power applications with power ratings of 45W or up and it can support voltage step requests up to 21V. The device operates in quasi-resonant mode to provide high efficiency and it also provides a number of key built-in protection features. The iW1796 can achieve tight multi-level constant voltage and multi-level constant current regulation without a traditional secondary feedback circuit. It also eliminates the need for loop compensation components while maintaining stability over all operating conditions.

The iW1796 is optimized to work with Dialog's secondary-side controller supporting XM-Comm technology, such as iW662/3, etc. for various rapid charge protocols, such as Qualcomm® Quick Charge™ 2.0 and 3.0 (QC2.0 – iW662/3 and QC3.0 – iW662) technologies, Huawei Fast Charger Protocol (FCP) (iW663), etc. to achieve fast and smooth voltage transitions upon request by mobile devices (MD). When paired with the iW662/3, the iW1796 completely eliminates the optocoupler between primary and secondary side. Using Dialog's proprietary transformer communication technology, XM-Comm, the iW662/3 can communicate with the iW1796 to send output voltage requests, output current limits, output voltage undershoot and over voltage information without any additional external components. The iW1796 paired with the iW662/3 can provide fast dynamic load response in typical AC/DC rapid charge adapter designs.

The iW1796 can provide no-load power consumption for a typical 5V output setting of less than 75mW with ample margin. The no-load power consumption can be reduced to less than 20mW with an optional, external active start-up DFET.

Dialog's innovative proprietary technology ensures that power supplies designed with the iW662/3 and iW1796 can provide various output voltage configurations for QC2.0/QC3.0/FCP and other proprietary protocols, with various user-selected output current limit combinations.

Qualcomm® Quick Charge™ 2.0 and 3.0 are products of Qualcomm Technologies, Inc.

2 Features

- Supports 45W or up application circuit designs
- Integrated XM-Comm technology eliminates secondary-to-primary optocoupler
 - Transformer communication for all the rapid charge information: output voltage request, output current limit, output voltage undershoot, and over-voltage protection
- RC charging V_{CC} technology enables ultra-low no-load power of <75mW with ample margin at 230V_{AC} and 5V output voltage setting
 - <20mW achievable (at 230V_{AC}/5V_{OUT}) with an external active startup circuit
- High V_{CC} pin voltage rating eliminates external V_{CC} LDO
- Tight multi-level constant-voltage and multi-level constant-current regulation with primary-side feedback and control
- Fast dynamic load response (DLR)
- Proprietary optimized load adaptive maximum constant frequency PWM switching with quasi-resonant operation achieves best size, efficiency, and common mode noise
- Multi-mode PWM/PFM control improves efficiency at various load conditions
- User-configurable 4-level cable drop compensation independent of output voltage
- **EZ-EMI**® design enhances manufacturability
- Built-in single-point fault protections against output short-circuit including soft short and half short, output over-voltage, and output over-current
- Advanced fault control technology addresses issues of soft shorts in cables and connectors by effectively reducing the average output power at fault conditions without latch
- Over-temperature protection with internal OTP control
- No audible noise over entire operating range
- Supports rapid charge technologies, such as QC 2.0 and 3.0 technologies, FCP, etc.

High Performance AC/DC Primary-Side Rapid Charge™ PWM Controller Supporting XM-Comm Technology

3 Applications

- Rapid-charging AC/DC adapters for smart phones, tablets and other portable devices

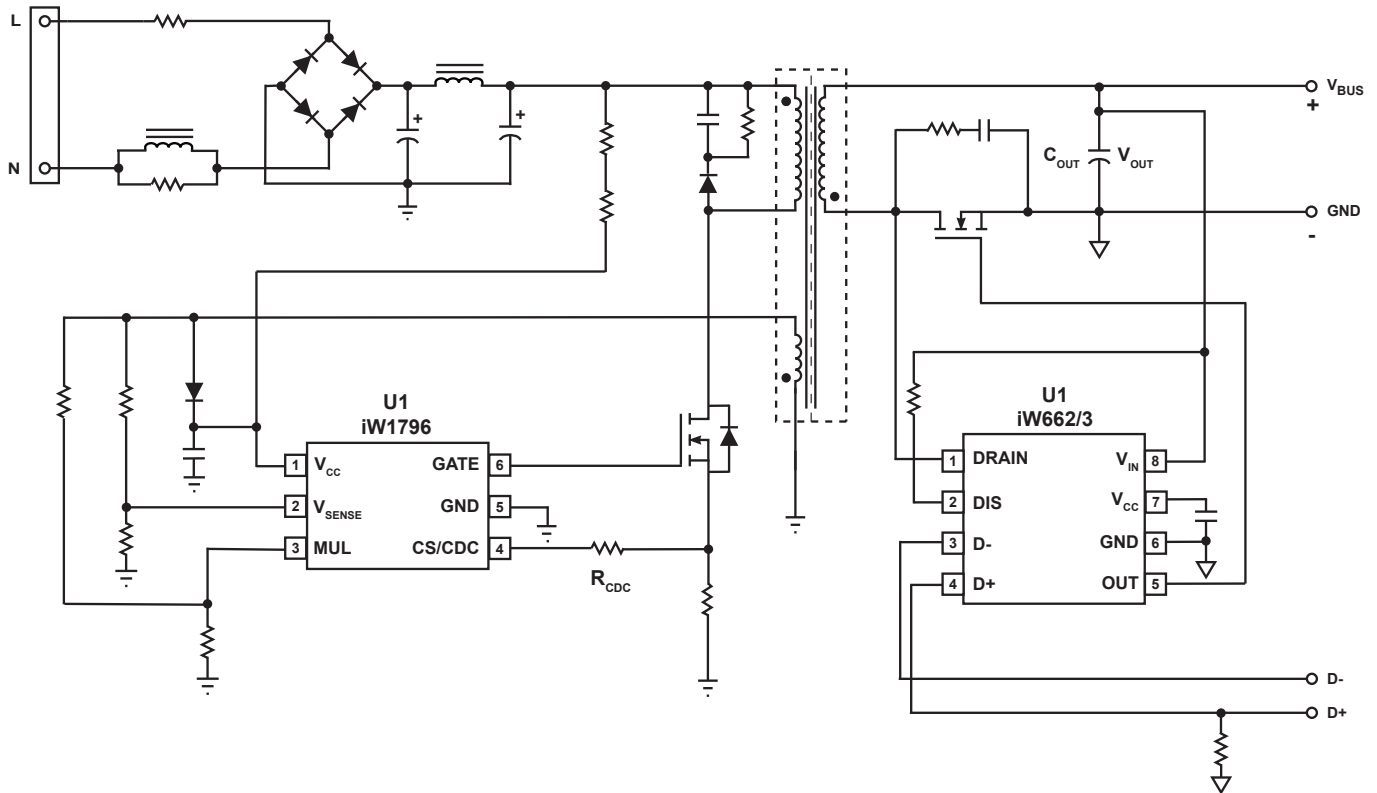

Figure 3.1 : iW1796 Typical Application Circuit for Multi-Level Output Voltage and Current (Using iW662/3 as Secondary-Side Controller for Rapid Charge Protocols. Achieving < 75mW No-Load Power Consumption (with ample margin) in Typical 15W Design.)

High Performance AC/DC Primary-Side Rapid Charge™ PWM Controller Supporting XM-Comm Technology

4 Pinout Description

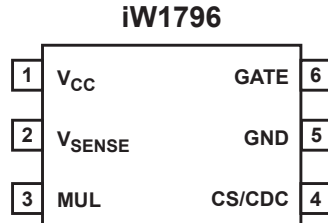

Figure 4.1 : 6-Lead SOT23-6 Package

Pin Number	Pin Name	Type	Pin Description
1	V _{CC}	Power Input	IC power supply.
2	V _{SENSE}	Analog Input	Auxiliary voltage sense. Used for primary-side regulation and secondary-to-primary communication through main transformer.
3	MUL	Analog Output	Used for auxiliary winding open detection with or without external ASU control.
4	CS/CDC	Analog Input	Primary-side current sense. Used for cycle-by-cycle peak-current control and limit in primary-side CV/CC regulation. During configuration stage, used to configure the CDC compensation level.
5	GND	Ground	Ground.
6	GATE	Output	Gate drive for external MOSFET switch.

High Performance AC/DC Primary-Side Rapid Charge™ PWM Controller Supporting XM-Comm Technology

5 Absolute Maximum Ratings

Absolute maximum ratings are the parameter values or ranges which can cause permanent damage if exceeded. For maximum safe operating conditions, refer to the Electrical Characteristics section.

Parameter	Symbol	Value	Units
DC supply voltage range (pin 1, $I_{CC} = 20\text{mA max}$)	V_{CC}	-0.3 to 45.0	V
Continuous DC supply current at V_{CC} pin ($V_{CC} = 15\text{V}$)	I_{CC}	20	mA
V_{SENSE} input (pin 2, $I_{VSENSE} \leq 10\text{mA}$)		-0.7 to 10.0	V
MUL (pin 3)		-0.7 to 5.0	V
CS/CDC (pin 4)		-0.7 to 5.0	V
GATE (pin 6)		-0.3 to 30	V
Maximum junction temperature	T_{JMAX}	150	°C
Operating junction temperature	T_{JOPT}	-40 to 150	°C
Storage temperature	T_{STG}	-65 to 150	°C
Thermal resistance junction-to-ambient	θ_{JA}	208	°C/W
ESD rating per JEDEC JS-001-2017		±2,000	V
Latch-up test per JESD78E		±100	mA

Note 1. Stresses beyond those listed under “Absolute maximum ratings” may cause permanent damage to the device. These are stress ratings only, so functional operation of the device at these or any other conditions beyond those indicated in the operational sections of the specification are not implied. Exposure to absolute maximum rating conditions for extended periods may affect device reliability.

High Performance AC/DC Primary-Side Rapid Charge™ PWM Controller Supporting XM-Comm Technology

6 Physical Dimensions

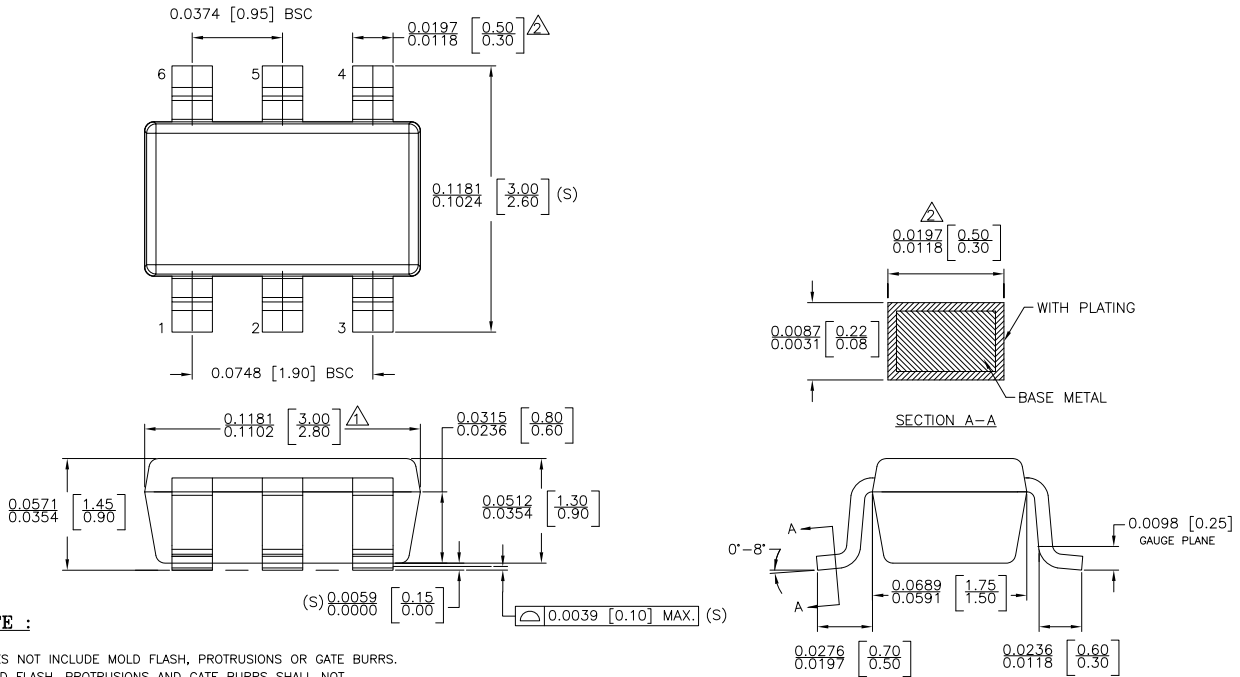

NOTE :

- △ DOES NOT INCLUDE MOLD FLASH, PROTRUSIONS OR GATE BURRS. MOLD FLASH, PROTRUSIONS AND GATE BURRS SHALL NOT EXCEED 0.127 MM PER SIDE.
- △ DOES NOT INCLUDE INTER-LEAD FLASH OR PROTRUSIONS. INTER-LEAD FLASH AND PROTRUSIONS SHALL NOT EXCEED 0.127 MM PER SIDE.
- 3. DIE IS FACING UP FOR MOLD. DIE IS FACING DOWN FOR TRIM/FORM.
- 4. THIS PART IS COMPLIANT WITH EIAJ SPECIFICATION SC74A AND JEDEC SPECIFICATION MO-178AB.
- 5. LEAD SPAN/STAND OFF HEIGHT/COPLANARITY ARE CONSIDERED AS SPECIAL CHARACTERISTIC(S)
- 6. CONTROLLING DIMENSIONS IN INCHES. [mm]

STATUS: RELEASED		SCALE: DO NOT SCALE
TERMINAL FINISH: 100% Sn or NiPdAu (PPF)		
TITLE: 6 SOT23 PACKAGE OUTLINE		
REV: A	REVISION NOTE: NEW DRAWING	DATE: 02-MAR-2015

Figure 6.1 : SOT23-6 package outline drawing

7 Ordering Information

Part Number	Secondary-Side Controller	Options				Package	Description
		Protocol Supported	Default k_{CC} at Start-up	CC Shutdown Voltage	k_{CC} Compensation for $V_{BUS} > 6V$		
iW1796-09	iW662-01/02	QC2.0/3.0	0.5	3.0V	No	SOT23-6	Tape & Reel ¹
iW1796-19	iW662-03	QC2.0/3.0/PE	0.5	3.0V	Yes	SOT23-6	Tape & Reel ¹

Note 1: Tape & Reel packing quantity is 3,000/reel. Minimum packing quantity is 3,000.

High Performance AC/DC Primary-Side Rapid Charge™ PWM Controller Supporting XM-Comm Technology

Disclaimer

Information in this document is believed to be accurate and reliable. However, Dialog Semiconductor does not give any representations or warranties, expressed or implied, as to the accuracy or completeness of such information. Dialog Semiconductor furthermore takes no responsibility whatsoever for the content in this document if provided by any information source outside of Dialog Semiconductor.

Dialog Semiconductor reserves the right to change without notice the information published in this document, including without limitation the specification and the design of the related semiconductor products, software and applications.

Applications, software, and semiconductor products described in this document are for illustrative purposes only. Dialog Semiconductor makes no representation or warranty that such applications, software and semiconductor products will be suitable for the specified use without further testing or modification. Unless otherwise agreed in writing, such testing or modification is the sole responsibility of the customer and Dialog Semiconductor excludes all liability in this respect.

Customer notes that nothing in this document may be construed as a license for customer to use the Dialog Semiconductor products, software and applications referred to in this document. Such license must be separately sought by customer with Dialog Semiconductor.

All use of Dialog Semiconductor products, software and applications referred to in this document are subject to [Dialog Semiconductor's Standard Terms and Conditions of Sale](#), available on the company website (www.dialog-semiconductor.com) unless otherwise stated.

Dialog and the Dialog logo are trademarks of Dialog Semiconductor plc or its subsidiaries. All other product or service names are the property of their respective owners.

Qualcomm is a trademark of Qualcomm Incorporated, registered in the United States and other countries. Qualcomm Quick Charge is a trademark of Qualcomm Incorporated. All Qualcomm Incorporated marks are used with permission.

© 2018 Dialog Semiconductor. All rights reserved.

RoHS Compliance

Dialog Semiconductor's suppliers certify that its products are in compliance with the requirements of Directive 2011/65/EU of the European Parliament on the restriction of the use of certain hazardous substances in electrical and electronic equipment. RoHS certificates from our suppliers are available on request.

Contacting Dialog Semiconductor

United Kingdom (Headquarters)
Dialog Semiconductor (UK) LTD
Phone: +44 1793 757700

Germany
Dialog Semiconductor GmbH
Phone: +49 7021 805-0

The Netherlands
Dialog Semiconductor B.V.
Phone: +31 73 640 8822

Email
info_pcbg@diasemi.com

North America
Dialog Semiconductor Inc.
Phone: +1 408 845 8500

Japan
Dialog Semiconductor K. K.
Phone: +81 3 5769 5100

Taiwan
Dialog Semiconductor Taiwan
Phone: +886 281 786 222

Web site:
www.dialog-semiconductor.com

Hong Kong
Dialog Semiconductor Hong Kong
Phone: +852 2607 4271

Korea
Dialog Semiconductor Korea
Phone: +82 2 3469 8200

China (Shenzhen)
Dialog Semiconductor China
Phone: +86 755 2981 3669

China (Shanghai)
Dialog Semiconductor China
Phone: +86 21 5424 9058