

AC/DC Primary-Side DLNK Rapid Charge™ Controller with High Performance Voltage/Current Control

1 Description

The iW1797 is a high performance AC/DC power supply controller for rapid charge applications that supports high resolution voltage/current control. The device can support high power applications with power ratings of 45W or up and it can support 10mV voltage step requests. It uses Dialog's **PrimAccurate™** technology to minimize external component count and simplify system design. The device operates in quasi-resonant mode to provide high efficiency and it also provides a number of key built-in protection features. The iW1797 can achieve tight multi-level constant voltage and multi-level constant current regulation without a traditional secondary feedback circuit. It also eliminates the need for loop compensation components while maintaining stability over all operating conditions.

The iW1797 is optimized to work with Dialog's secondary-side controllers that use the proprietary digital link (DLNK) technology. The iW1797 and DLNK-based secondary-side controller chipset together can implement various rapid charge protocols, such as USB Power Delivery (USB PD), Qualcomm® Quick Charge™ 2.0 and 3.0 (QC2.0 and QC3.0) technologies and Huawei Fast Charge (FCP) technology, etc. to achieve fast and smooth voltage transitions upon request by mobile devices (MD). The iW1797 and compatible secondary-side controller from Dialog use the DLNK communication protocol for output voltage requests, output current limits, output voltage undershoot and over voltage information from the secondary to the primary.

The iW1797 can provide no-load power consumption for a typical 5V output setting of less than 75mW with ample margin. The no-load power consumption can be reduced to less than 20mW with an optional, external active start-up DFET.

Dialog's innovative proprietary technology ensures that power supplies designed with the iW1797 and Dialog's secondary-side controllers can provide output voltage configurations of 3.3V to 21V for USB PD, 5V/9V/12V for QC2.0 and 3.6V to 12V in 200mV increments for QC3.0, 5V/9V for Huawei FCP and other proprietary protocols.

Qualcomm® Quick Charge™ 2.0 and 3.0 are products of Qualcomm Technologies, Inc.

2 Features

- Supports 45W or up application circuit designs
- Supports 10mV DLNK voltage step requests required by USB PD programmable power supply (PPS) or other proprietary rapid charge protocols
- RC charging V_{CC} technology enables ultra-low no-load power of <75mW with ample margin at 230V_{AC} and 5V output voltage setting
 - <20mW achievable (at 230V_{AC}/5V_{OUT}) with an external active startup circuit
- High V_{CC} pin voltage rating eliminates external V_{CC} LDO
- Tight multi-level constant-voltage and multi-level constant-current regulation with primary-side feedback and control
- Proprietary optimized load adaptive maximum constant frequency PWM switching with quasi-resonant operation achieves best size, efficiency, and common mode noise
- Backward compatible with QC2.0/3.0, Huawei FCP and other proprietary rapid charge protocols with secondary-side interface circuits
- Multi-mode PWM/PFM control improves efficiency at various load conditions
- No audible noise over entire operating range
- User-configurable 4-level cable drop compensation independent of output voltage
- Proprietary secondary-to-primary digital communication with single optocoupler for all the rapid charge information:
 - Output voltage request
 - Output current limit
 - Output voltage undershoot detection for fast dynamic load response
 - Over-voltage protection
- **EZ-EMI®** design enhances manufacturability
- Built-in single-point fault protections against output short-circuit including soft short and half short, output over-voltage, and output over-current
- Advanced fault control technology addresses issues of soft shorts in cables and connectors by effectively reducing the average output power at fault conditions without latch
- Over-temperature protection with internal OTP control

AC/DC Primary-Side DLNK Rapid Charge™ Controller with High Performance Voltage/Current Control

3 Applications

- Rapid-charging AC/DC adapters for smart phones, tablets and other portable devices.

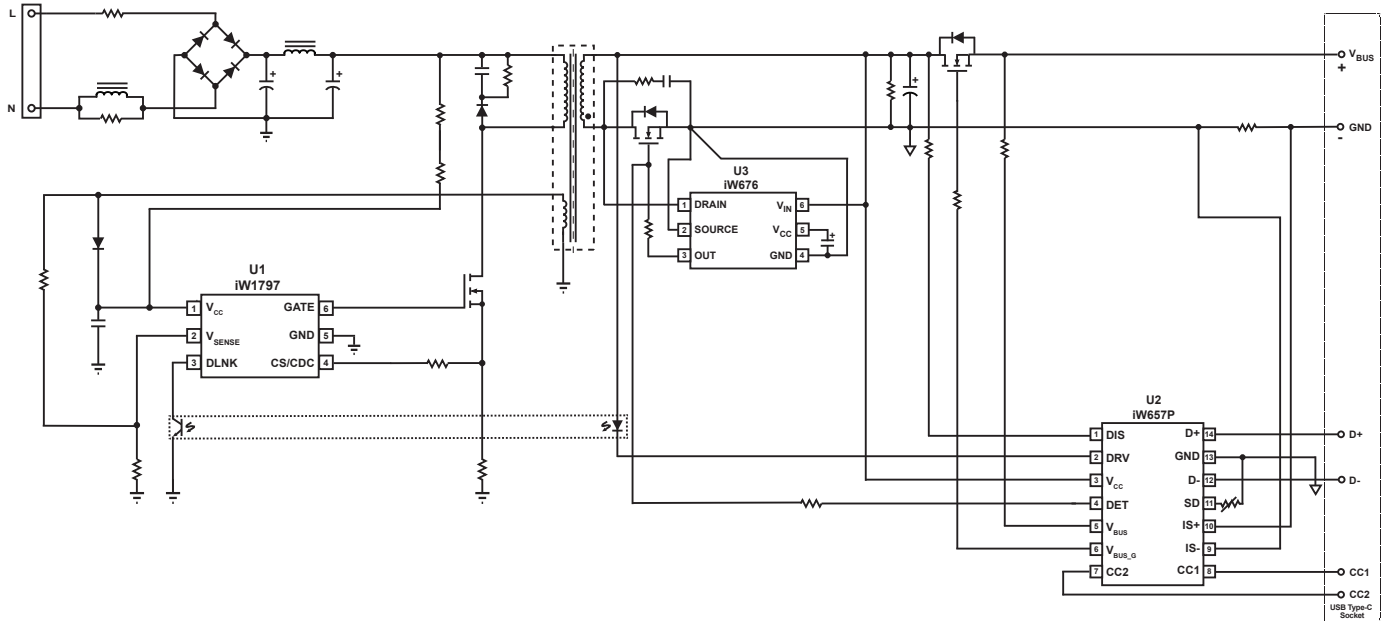

**Figure 3.1 : iW1797 Typical Application Circuit for USB PD
(Using iW657P as Secondary-Side Controller for USB PD and iW676 as Synchronous Rectifier Controller.)**

AC/DC Primary-Side DLNK Rapid Charge™ Controller with High Performance Voltage/Current Control

4 Pinout Description

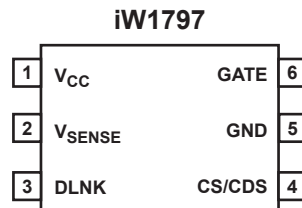

Figure 4.1 : 6-Lead SOT23-6 Package

Pin Number	Pin Name	Type	Pin Description
1	V _{CC}	Power Input	IC power supply.
2	V _{SENSE}	Analog Input	Auxiliary voltage sense. Used for primary-side regulation.
3	DLNK	Analog Output	Digital communication link signal. Used for secondary-side to primary-side communication for all rapid charge information, which includes output voltage requests, output current limits, output voltage undershoot, and over-voltage protection.
4	CS/CDC	Analog Input	Primary-side current sense. Used for cycle-by-cycle peak-current control and limit in primary-side CV/CC regulation. During configuration stage, used to configure the CDC compensation level.
5	GND	Ground	Ground.
6	GATE	Output	Gate drive for external MOSFET switch.

AC/DC Primary-Side DLNK Rapid Charge™ Controller with High Performance Voltage/Current Control

5 Absolute Maximum Ratings

Absolute maximum ratings are the parameter values or ranges which can cause permanent damage if exceeded. For maximum safe operating conditions, refer to the Electrical Characteristics section.

Parameter	Symbol	Value	Units
DC supply voltage range (pin 1, $I_{CC} = 20\text{mA max}$)	V_{CC}	-0.3 to 45.0	V
Continuous DC supply current at V_{CC} pin ($V_{CC} = 15\text{V}$)	I_{CC}	20	mA
V_{SENSE} input (pin 2, $I_{VSENSE} \leq 10\text{mA}$)		-0.7 to 10.0	V
DLNK (pin 3)		-0.7 to 5.0	V
CS/CDC (pin 4)		-0.7 to 5.0	V
GATE (pin 6)		-0.3 to 30	V
Maximum junction temperature	T_{JMAX}	150	°C
Operating junction temperature	T_{JOPT}	-40 to 150	°C
Storage temperature	T_{STG}	-65 to 150	°C
Thermal resistance junction-to-ambient	θ_{JA}	208	°C/W
ESD rating per JEDEC JS-001-2017		$\pm 2,000$	V
Latch-up test per JESD78E		± 100	mA

Note 1. Stresses beyond those listed under “Absolute maximum ratings” may cause permanent damage to the device. These are stress ratings only, so functional operation of the device at these or any other conditions beyond those indicated in the operational sections of the specification are not implied. Exposure to absolute maximum rating conditions for extended periods may affect device reliability.

AC/DC Primary-Side DLNK Rapid Charge™ Controller with High Performance Voltage/Current Control

6 Physical Dimensions

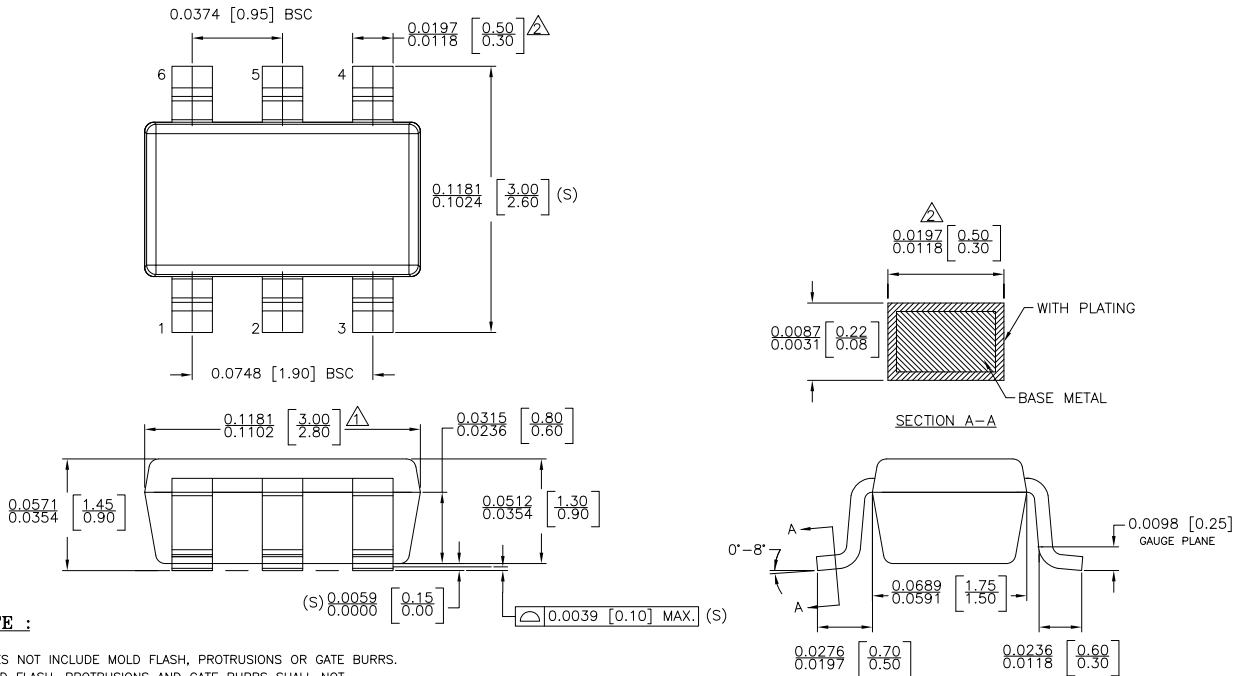

NOTE :

- 1. DOES NOT INCLUDE MOLD FLASH, PROTRUSIONS OR GATE BURRS. MOLD FLASH, PROTRUSIONS AND GATE BURRS SHALL NOT EXCEED 0.127 MM PER SIDE.
- 2. DOES NOT INCLUDE INTER-LEAD FLASH OR PROTRUSIONS. INTER-LEAD FLASH AND PROTRUSIONS SHALL NOT EXCEED 0.127 MM PER SIDE.
- 3. DIE IS FACING UP FOR MOLD. DIE IS FACING DOWN FOR TRIM/FORM.
- 4. THIS PART IS COMPLIANT WITH EIAJ SPECIFICATION SC74A AND JEDEC SPECIFICATION MO-178AB.
- 5. LEAD SPAN/STAND OFF HEIGHT/COPLANARITY ARE CONSIDERED AS SPECIAL CHARACTERISTIC(S).
- 6. CONTROLLING DIMENSIONS IN INCHES. [mm]

STATUS: RELEASED		SCALE: DO NOT SCALE
TERMINAL FINISH: 100% Sn or NiPdAu (PPF)		
TITLE: 6 SOT23 PACKAGE OUTLINE		
REV: A	REVISION NOTE: NEW DRAWING	DATE: 02-MAR-2015

Figure 6.1 : SOT23-6 package outline drawing

7 Ordering Information

Part Number	Options						Package	Description
	Protocol Supported	Default k_{CC} at Start-up	CC Shutdown Voltage	OVP/OTP Latch	CC Shutdown Latch	Supported DLNK Voltage Information Resolution		
iW1797-05	Direct Charge	0.422	2.9V for $V_{BUS} \leq 12V$, 3.2V for $V_{BUS} > 12V$	No	No	10mV/Step up to 21V	SOT23-6	Tape & Reel ¹

Note 1: Tape & Reel packing quantity is 3,000/reel. Minimum packing quantity is 3,000.

AC/DC Primary-Side DLNK Rapid Charge™ Controller with High Performance Voltage/Current Control

Disclaimer

Information in this document is believed to be accurate and reliable. However, Dialog Semiconductor does not give any representations or warranties, expressed or implied, as to the accuracy or completeness of such information. Dialog Semiconductor furthermore takes no responsibility whatsoever for the content in this document if provided by any information source outside of Dialog Semiconductor.

Dialog Semiconductor reserves the right to change without notice the information published in this document, including without limitation the specification and the design of the related semiconductor products, software and applications.

Applications, software, and semiconductor products described in this document are for illustrative purposes only. Dialog Semiconductor makes no representation or warranty that such applications, software and semiconductor products will be suitable for the specified use without further testing or modification. Unless otherwise agreed in writing, such testing or modification is the sole responsibility of the customer and Dialog Semiconductor excludes all liability in this respect.

Customer notes that nothing in this document may be construed as a license for customer to use the Dialog Semiconductor products, software and applications referred to in this document. Such license must be separately sought by customer with Dialog Semiconductor.

All use of Dialog Semiconductor products, software and applications referred to in this document are subject to [Dialog Semiconductor's Standard Terms and Conditions of Sale](#), available on the company website (www.dialog-semiconductor.com) unless otherwise stated.

Dialog and the Dialog logo are trademarks of Dialog Semiconductor plc or its subsidiaries. All other product or service names are the property of their respective owners.

Qualcomm is a trademark of Qualcomm Incorporated, registered in the United States and other countries. Qualcomm Quick Charge is a trademark of Qualcomm Incorporated. All Qualcomm Incorporated marks are used with permission.

© 2018 Dialog Semiconductor. All rights reserved.

RoHS Compliance

Dialog Semiconductor's suppliers certify that its products are in compliance with the requirements of Directive 2011/65/EU of the European Parliament on the restriction of the use of certain hazardous substances in electrical and electronic equipment. RoHS certificates from our suppliers are available on request.

Contacting Dialog Semiconductor

United Kingdom (Headquarters)
Dialog Semiconductor (UK) LTD
Phone: +44 1793 757700

Germany
Dialog Semiconductor GmbH
Phone: +49 7021 805-0

The Netherlands
Dialog Semiconductor B.V.
Phone: +31 73 640 8822

Email
info_pcbg@diasemi.com

North America
Dialog Semiconductor Inc.
Phone: +1 408 845 8500

Japan
Dialog Semiconductor K. K.
Phone: +81 3 5769 5100

Taiwan
Dialog Semiconductor Taiwan
Phone: +886 281 786 222

Web site:
www.dialog-semiconductor.com

Hong Kong
Dialog Semiconductor Hong Kong
Phone: +852 2607 4271

Korea
Dialog Semiconductor Korea
Phone: +82 2 3469 8200

China (Shenzhen)
Dialog Semiconductor China
Phone: +86 755 2981 3669

China (Shanghai)
Dialog Semiconductor China
Phone: +86 21 5424 9058