

The documentation and process conversion measures necessary to comply with this document shall be completed by 18 June 2012.

[INCH-POUND]

MIL-PRF-19500/382J  
18 April 2012  
SUPERSEDING  
MIL-PRF-19500/382H  
16 June 2010

## PERFORMANCE SPECIFICATION SHEET

\* SEMICONDUCTOR DEVICE, TRANSISTOR, PNP, SILICON, LOW-POWER, TYPES 2N2944A, 2N2945A, 2N2945AM, AND 2N2946A, 2N2944AUB, 2N2945AUB, 2N2945AUBM, AND 2N2946AUB, JAN, JANTX, JANTXV, JANS, JANHC, JANKC, JANSM, JANSJ, JANSF, JANSR, JANSF, JANSG, JANSH, JANHCM, JANHCD, JANHCP, JANHCL, JANHCR, JANHCF, JANHCG, JANHCH, JANKCM, JANKCD, JANKCP, JANKCL, JANKCR, JANKCF, JANKCG, AND JANKCH

This specification is approved for use by all Departments and Agencies of the Department of Defense.

The requirements for acquiring the product described herein shall consist of this specification sheet and MIL-PRF-19500.

### 1. SCOPE

\* 1.1 Scope. This specification covers the performance requirements for low-power, high-speed chopper, PNP, silicon transistors. A 'M' and UB'M' suffix will indicate a matched pair. Four levels of product assurance are provided for each encapsulated device type as specified in MIL-PRF-19500. Two levels of product assurance are provided for each unencapsulated device type. Radiation hardness assurance (RHA) level designators "M", "D", "P", "L", "R", "F", "G", and "H" are appended to the device prefix to identify devices which have passed RHA requirements.

1.2 Physical dimensions. See [figure 1](#) (similar to TO-46), [figure 2](#) (surface mount), and [figure 3](#) (die).

1.3 Maximum ratings, unless otherwise specified  $T_A = +25^\circ\text{C}$ .

Types	$P_T$ $T_A = +25^\circ\text{C}$ (1) (2)		$V_{EBO}$	$V_{CBO}$	$V_{CEO}$	$V_{ECO}$	$I_C$	$T_J$ and $T_{STG}$	$R_{\theta JA}$ (3) (4)	$R_{\theta JSP}$
	<u>mW</u>	<u>mW</u>								
2N2944A	400	N/A	-15	-15	-10	-10	-100	-65 to	435	N/A
2N2945A, AM	400	N/A	-25	-25	-20	-20	-100	+200	435	N/A
2N2946A	400	N/A	-40	-40	-35	-35	-100		435	N/A
2N2944AUB	400	800	-15	-15	-10	-10	-100	-65 to	435 (5)	90
2N2945AUB	400	800	-25	-25	-20	-20	-100	+200	435 (5)	90
2N2945AUBM	400	800	-25	-25	-20	-20	-100		435 (5)	90
2N2946AUB	400	800	-40	-40	-35	-35	-100		435 (5)	90

(1) For derating, see figures 4 and 5.

(2) See 3.3 for abbreviations.

(3) For thermal curves, see figures 6 and 7.

\* Comments, suggestions, or questions on this document should be to DLA Land and Maritime, ATTN: VAC, P.O. Box 3990, Columbus, OH 43218-3990, or emailed to [Semiconductor@dla.mil](mailto:Semiconductor@dla.mil). Since contact information can change, you may want to verify the currency of this address information using the ASSIST Online database at <https://assist.daps.dla.mil>.

MIL-PRF-19500/382J

1.3 Maximum ratings, unless otherwise specified  $T_A = +25^\circ\text{C}$ . - Continued.

- (4) For non-thermal conductive PCB or unknown PCB surface mount conditions in free air, substitute [figure 6](#) for the UB package and use  $R_{\theta JA}$ .
- (5)  $T_A = +55^\circ\text{C}$  for UB on printed circuit board (PCB), PCB = FR4 .0625 inch (1.59 mm) 1 - layer 1 Oz Cu, horizontal, still air, pads (UB) = .034 inch (0.86 mm) x .048 inch (1.22 mm),  $R_{\theta JA}$  with a defined thermal resistance condition included is measured at  $P_T = 400$  mW.

1.4 Primary electrical characteristics unless otherwise specified  $T_A = +25^\circ\text{C}$ .

Limits	$h_{FE1}$ $V_{CE} = -0.5$ V dc $I_C = -1$ mA dc			$h_{FE} (inv)_1$ $V_{EC} = -0.5$ V dc $I_E = -200$ $\mu$ A dc			$r_{ec} (on)_2$ $I_B = -1$ mA dc $I_e = 100$ $\mu$ A ac(rms) $I_E = 0$ ; $f = 1$ kHz		
	2N2944A, UB	2N2945 A, UB      AM, AUBM		2N2946A, UB	2N2944A, UB	2N2945A, 2N2945AUB, 2N2945AM, 2N2945AUBM	2N2946A, UB	2N2944A, UB	2N2945A, 2N2945AUB, 2N2945AM, 2N2945AUBM
Min Max	100	70	70 200	50	50	30	20	<u>ohms</u> 4	<u>ohms</u> 6

Limits	$r_{ec} (on)_2$ $I_B = -1$ mA dc $I_e = 100$ $\mu$ A ac(rms) $I_E = 0$ ; $f = 1$ kHz		$V_{EC} (ofs)$					
			$I_B = -200$ $\mu$ A dc $I_E = 0$			$I_b = -1.0$ mA dc $I_E = 0$		
	2N2946A, UB	2N2944A, UB	2N2945A, 2N2945AUB, 2N2945AM, 2N2945AUBM	2N2946A, UB	2N2944A, UB	2N2945A, 2N2945AUB, 2N2945AM, 2N2945AUBM	2N2946A, UB	
Min Max	<u>ohms</u> 8	<u>mV dc</u> -0.3	<u>mV dc</u> -0.5	<u>mV dc</u> -0.8	<u>mV dc</u> -0.6	<u>mV dc</u> -1.0	<u>mV dc</u> -2.0	

Limits	$ h_{fe} $ $f = 1$ MHz $V_{CE} = -6$ V dc $I_C = -1$ mA dc			$C_{obo}$ $V_{CB} = -6$ V dc $I_E = 0$ $100$ kHz $\leq f \leq 1$ MHz		$C_{ibo}$ $V_{EB} = -6$ V dc $I_C = 0$ $100$ kHz $\leq f \leq 1$ MHz	
	2N2944A, UB	2N2945A, 2N2945AUB, 2N2945AM, 2N2945AUBM	2N2946A, UB	2N2945A, 2N2945AUB, 2N2945AM, 2N2945AUBM			
Min Max	15 55	10 55	5 55	<u>pF</u> 10	<u>pF</u> 6		

Ltr.	Dimensions				Notes
	Inches		Millimeters		
	Min	Max	Min	Max	
CD	.178	.195	4.52	4.95	
CH	.065	.085	1.65	2.16	
HD	.209	.230	5.31	5.84	
LC	.100 TP		2.54 TP		5
LD	.016	.021	0.41	0.53	
LL	.500	1.750	12.70	44.45	6
LU	.016	.019	0.41	0.48	6
L1		.050		1.27	6
L2	.250		6.35		6
Q		.040		1.02	3
TL	.028	.048	0.71	1.22	8
TW	.036	.046	0.91	1.17	4
r		.010		0.25	9
$\alpha$	45° TP		45° TP		5

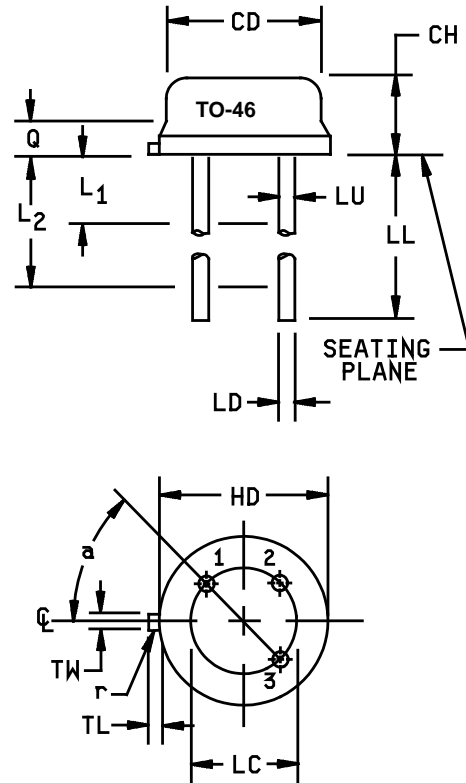

NOTES:

1. Dimensions are in inches.
2. Millimeters are given for general information only.
3. Symbol TL is measured from HD maximum.
4. Details of outline in this zone are optional.
5. Leads at gauge plane .054 inch (1.37 mm) +.001 inch (0.03 mm) -.000 inch (0.00 mm) below seating plane shall be within .007 inch (0.18 mm) radius of TP relative to tab. Device may be measured by direct methods or by gauge.
6. Symbol LU applies between L<sub>1</sub> and L<sub>2</sub>. Dimension LD applies between L<sub>2</sub> and LL minimum.
7. Lead number three is electrically connected to case.
8. Beyond r maximum, TW shall be held for a minimum length of .011 inch (0.28 mm).
9. Symbol r applied to both inside corners of tab.
10. In accordance with ASME Y14.5M, diameters are equivalent to  $\phi x$  symbology.
11. Lead 1 is emitter, lead 2 is base, and lead 3 is collector.

FIGURE 1. Physical dimensions (similar to TO-46).

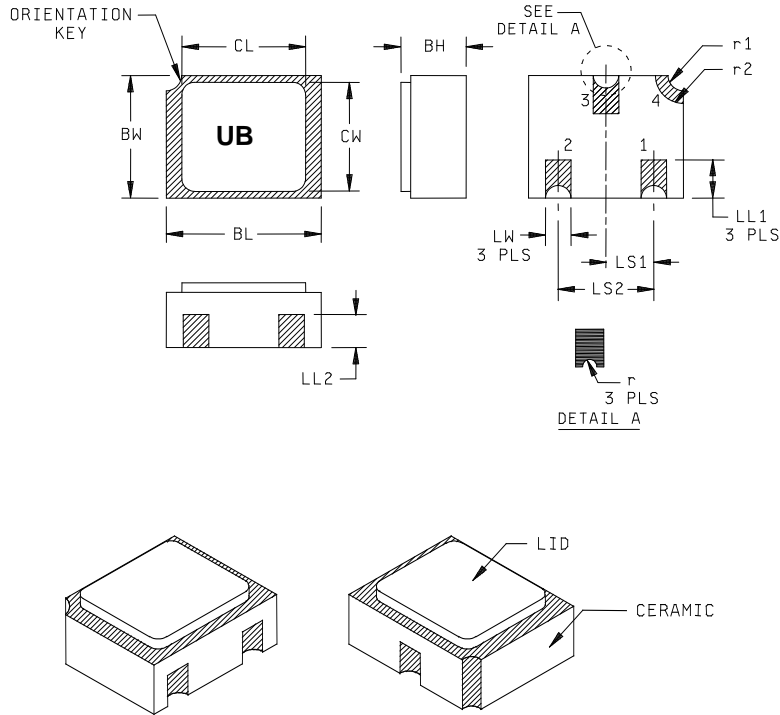

Symbol	Dimensions				Note	Symbol	Dimensions				Note
	Inches		Millimeters				Inches		Millimeters		
	Min	Max	Min	Max			Min	Max	Min	Max	
BH	.046	.056	1.17	1.42		LS1	.035	.039	0.89	0.99	
BL	.115	.128	2.92	3.25		LS2	.071	.079	1.80	2.01	
BW	.085	.108	2.16	2.74		LW	.016	.024	0.41	0.61	
CL		.128		3.25		r		.008		0.20	
CW		.108		2.74		r1		.012		0.31	
LL1	.022	.038	0.56	0.97		r2		.022		0.56	
LL2	.017	.035	0.43	0.89							

NOTES:

1. Dimensions are in inches.
2. Millimeters are given for general information only.
3. Hatched areas on package denote metallized areas
4. Pad 1 = Base, Pad 2 = Emitter, Pad 3 = Collector, Pad 4 = Shielding connected to the lid.
5. In accordance with ASME Y14.5M, diameters are equivalent to  $\phi x$  symbology.

FIGURE 2. Physical dimensions, surface mount (UB version).

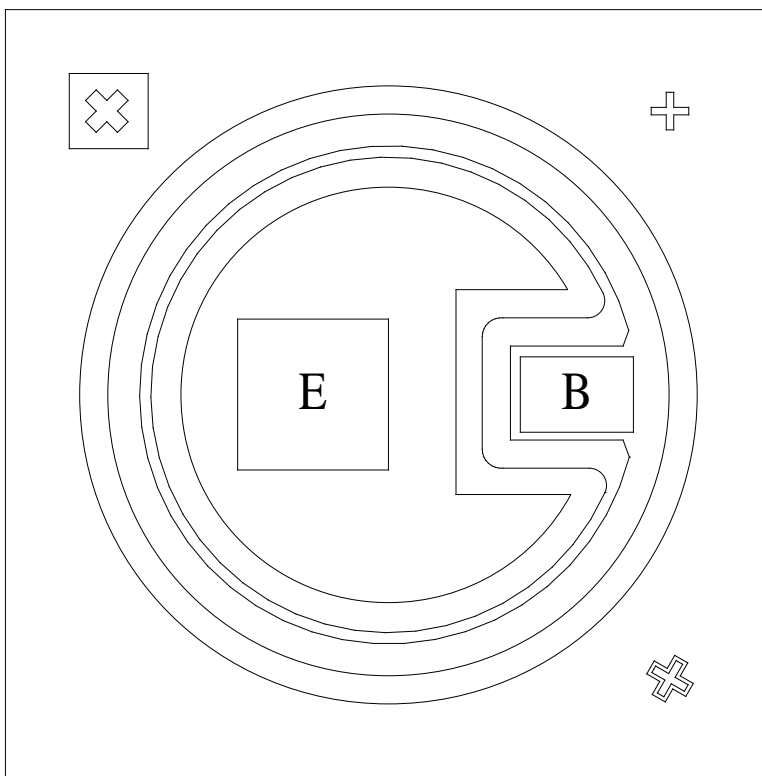

Die size: .020 x .020 inch (0.508 mm x 0.508 mm).  
Die thickness: .008 ±.0016 inch (0.203 mm ±0.041 mm).  
Base pad: .002 x .003 inch (0.051 mm x 0.076 mm).  
Emitter pad: .004 x .004 inch (0.102 mm x 0.102 mm).  
Back metal: Gold, 6,500 ±1,950 Ang.  
Top metal: Aluminum, 14,500 ±2,500 Ang.  
Back side: Collector.  
Glassivation: SiO<sub>2</sub>, 7,500 ±1,500 Ang.

FIGURE 3. Physical dimensions, JANKCA2N2944A through 2N2946A die (also valid for JANHCA2N2944A through 2N2946A).

## 2. APPLICABLE DOCUMENTS

2.1 General. The documents listed in this section are specified in sections 3, 4, or 5 of this specification. This section does not include documents cited in other sections of this specification or recommended for additional information or as examples. While every effort has been made to ensure the completeness of this list, document users are cautioned that they must meet all specified requirements of documents cited in sections 3, 4, or 5 of this specification, whether or not they are listed.

### 2.2 Government documents.

2.2.1 Specifications, standards, and handbooks. The following specifications, standards, and handbooks form a part of this document to the extent specified herein. Unless otherwise specified, the issues of these documents are those cited in the solicitation or contract.

#### DEPARTMENT OF DEFENSE SPECIFICATIONS

MIL-PRF-19500 - Semiconductor Devices, General Specification for.

#### DEPARTMENT OF DEFENSE STANDARDS

MIL-STD-750 - Test Methods for Semiconductor Devices.

(Copies of these documents are available online at <https://assist.daps.dla.mil/quicksearch> or <https://assist.daps.dla.mil> or from the Standardization Document Order Desk, 700 Robbins Avenue, Building 4D, Philadelphia, PA 19111-5094.)

2.3 Order of precedence. Unless otherwise noted herein or in the contract, in the event of a conflict between the text of this document and the references cited herein, the text of this document takes precedence. Nothing in this document, however, supersedes applicable laws and regulations unless a specific exemption has been obtained.

## 3. REQUIREMENTS

3.1 General. The individual item requirements shall be as specified in MIL-PRF-19500 and as modified herein.

3.2 Qualification. Devices furnished under this specification shall be products that are manufactured by a manufacturer authorized by the qualifying activity for listing on the applicable qualified manufacturers list before contract award (see 4.2 and 6.3).

3.3 Abbreviations, symbols, and definitions. Abbreviations, symbols, and definitions used herein shall be as specified in MIL-PRF-19500 and as follows.

$h_{FE}$ (inv)	Forward-current transfer ratio except that the collector and emitter shall be interchanged in the test circuit, i.e., $I_E/I_B$ .
$I_e$	Emitter current (rms).
M	Matched pair.
$r_{ec(ON)}$	Small-signal emitter-collector on-state resistance.
$R_{\theta JSP}$	Thermal resistance junction to solder pads.
$V_{(BR)ECO}$	Breakdown voltage, emitter to collector, with base open-circuited.
$V_{EC(ofs)}$	Emitter to collector offset voltage, i.e., open-circuit voltage between emitter collector when the base-collector junction is forward-biased.
$V_{ec}$	Emitter to collector voltage (rms).

3.4 Interface and physical dimensions. Interface and physical dimensions shall be as specified in MIL-PRF-19500, and on [figure 1](#) (similar to TO-46), [figure 2](#) (surface mount), and [figure 3](#) (die).

3.4.1 Lead finish. Lead finish shall be solderable in accordance with MIL-PRF-19500, MIL-STD-750, and herein. Where a choice of lead finish is desired, it shall be specified in the acquisition document (see [6.2](#)).

\* 3.5 Radiation hardness assurance (RHA). Radiation hardness assurance requirements, PIN designators, and test levels shall be as defined in MIL-PRF-19500.

3.6 Electrical performance characteristics. Unless otherwise specified herein, the electrical performance characteristics are as specified in [1.3](#), [1.4](#), and [table I](#).

3.7 Electrical test requirements. The electrical test requirements shall be as specified in [table I](#), and herein.

\* 3.8 Marking. Marking shall be in accordance with MIL-PRF-19500. At the option of the manufacturer, marking may be omitted from the body, but shall be retained on the initial container. The radiation hardness designator M, D, P, L, R, F, G, or H shall immediately precede (or replace) the device "2N" identifier (depending upon degree of abbreviation required).

3.9 Workmanship. Semiconductor devices shall be processed in such a manner as to be uniform in quality and shall be free from other defects that will affect life, serviceability, or appearance.

#### 4. VERIFICATION

\* 4.1 Classification of inspections. The inspection requirements specified herein are classified as follows:

a. Qualification inspection (see [4.2](#)).

b. Screening (see [4.3](#)).

\* c. Conformance inspection (see [4.4](#) and [table I](#) and [II](#)).

4.2 Qualification inspection. Qualification inspection shall be in accordance with MIL-PRF-19500 and as specified herein.

4.2.1. JANHC and JANKC qualification. JANHC and JANKC qualification inspection shall be in accordance with MIL-PRF-19500.

\* 4.2.2 Group E qualification. Group E inspection shall be performed for qualification or re-qualification only. In case qualification was awarded to a prior revision of the specification sheet that did not request the performance of [table III](#) tests, the tests specified in [table III](#) herein that were not performed in the prior revision shall be performed on the first inspection lot of this revision to maintain qualification.

4.3 Screening (JANS, JANTX, and JANTXV levels only). Screening shall be in accordance with table E-IV of MIL-PRF-19500 and as specified herein. The following measurements shall be made in accordance with table I herein. Devices that exceed the limits of table I herein shall not be acceptable.

Screen (see table E-IV of MIL-PRF-19500)	Measurement	
	JANS	JANTX and JANTXV
(1) 3c	Required, method 3131 of MIL-STD-750. (see 4.3.3)	Required, method 3131 of MIL-STD-750. (see 4.3.3)
9	$I_{CBO1}$ and $h_{FE} (inv)_1$	Not applicable
11	$I_{CBO1}$ ; $h_{FE} (inv)_1$ ; $\Delta I_{CBO1}$ = 100 percent of initial value or 0.2 nA dc for 2N2944 and 2N2945, 0.5 nA dc for 2N2946 $\Delta h_{FE} (inv)_1$ = 25 percent of initial value.	$I_{CBO1}$ and $h_{FE} (inv)_1$
12	See 4.3.2	See 4.3.2.
13	Subgroups 2 and 3 of table I herein; $\Delta I_{CBO1}$ = 100 percent of initial value or 0.2 nA dc for 2N2944 and 2N2945, 0.5 nA dc for 2N2946; $\Delta h_{FE} (inv)_1$ = 25 percent of initial value.	Subgroups 2 of table I herein; $\Delta I_{CBO1}$ = 100 percent of initial value or 0.2 nA dc for 2N2944A, 2N2945A, 2N2945AM, 2N2945AUB, and 2N2945AUBM. 0.5 nA dc for 2N2946A; $\Delta h_{FE} (inv)_1$ = 25 percent of initial value.

\* (1) Shall be performed any time after temperature cycling, screen 3a; JANTX and JANTXV levels do not need to be repeated in screening requirements.

4.3.1 Screening (JANH C and JANKC). Screening for JANHC and JANKC die shall be in accordance with MIL-PRF-19500 "Discrete Semiconductor Die/Chip Lot Acceptance". Burn-in duration for the JANKC level follows JANS requirements; the JANHC follows JANTX requirements.

4.3.2 Power burn-in conditions. Power burn-in conditions are as follows:  $V_{CB} = 10$  to 30 V dc. Power shall be applied to achieve  $T_J = +135^\circ\text{C}$  minimum using a minimum  $P_D = 75$  percent of  $P_T$  maximum rated as defined in 1.3. With approval of the qualifying activity and preparing activity, alternate burn-in criteria (hours, bias conditions,  $T_J$ , and mounting conditions) may be used for JANTX and JANTXV quality levels. A justification demonstrating equivalence is required. In addition, the manufacturing site's burn-in data and performance history will be essential criteria for burn-in modification approval. Use method 3100 of MIL-STD-750 to measure  $T_J$ .

4.3.3 Thermal impedance. The thermal impedance measurements shall be performed in accordance with method 3131 of MIL-STD-750 using the guidelines in that method for determining  $I_M$ ,  $I_H$ ,  $t_H$ ,  $t_{MD}$ , (and  $V_C$  where appropriate).



4.4 Conformance inspection. Conformance inspection shall be in accordance with MIL-PRF-19500.

4.4.1 Group A inspection. Group A inspection shall be conducted in accordance with MIL-PRF-19500 and [table I](#) herein.

4.4.2 Group B inspection. Group B inspection shall be conducted in accordance with the conditions specified for subgroup testing in E-VIa (JANS) of 19500 and [4.4.2.1](#) herein. Electrical measurements (end-points) requirements shall be in accordance with [table I](#), subgroup 2 herein. Delta requirements shall be in accordance with [4.5.6](#) herein. See [4.4.2.2](#) herein for JAN, JANTX, and JANTXV group B testing. Electrical measurements (end-points) requirements shall be after each step in [4.4.2.2](#) and shall be in accordance with [table I](#), subgroup 2 herein. Delta requirements shall be in accordance with [4.5.6](#) herein.

4.4.2.1 Group B inspection (JANS), table E-VIa of MIL-PRF-19500.

<u>Subgroup</u>	<u>Method</u>	<u>Condition</u>
B3	2037	Condition A.
B4	1037	2,000 cycles. No heat sink or forced air cooling on the devices shall be permitted. $V_{CB} = 10$ V dc. $t_{on} = t_{off} = 3$ minutes, power = 400 mW.
B5	1027	$V_{CB} = 10$ V dc. $P_D \geq 100$ percent of maximum rated $P_T$ (see <a href="#">1.3</a> ). (NOTE: If a failure occurs, resubmission shall be at the test conditions of the original sample).  Option 1: 96 hours minimum, sample size in accordance with table VIa of MIL-PRF-19500, adjust $T_A$ or $P_D$ to achieve $T_J = +275^\circ\text{C}$ minimum.  Option 2: 216 hours, sample size = 45, $c = 0$ ; adjust $T_A$ or $P_D$ to achieve $T_J = +225^\circ\text{C}$ minimum.

4.4.2.2 Group B inspection, (JAN, JANTX, and JANTXV), table E-VIb of MIL-PRF-19500. Separate samples may be used for each step. In the event of a lot failure, the resubmission requirements of MIL-PRF-19500 shall apply. In addition, all catastrophic failures during CI (conformance inspection) shall be analyzed to the extent possible to identify root cause and corrective action. Whenever a failure is identified as wafer lot and/or wafer processing related, the entire wafer lot and related devices assembled from the wafer lot shall be rejected unless an appropriate determined corrective action to eliminate the failures mode has been implemented and the devices from the wafer lot are screened to eliminate the failure mode. Electrical end-points shall be in accordance with [table I](#) subgroup 2, herein.

<u>Step</u>	<u>Method</u>	<u>Condition</u>
1	1026	Steady-state life: 1,000 hours, $V_{CB} = 10$ V dc, power shall be applied and ambient temperature adjusted to achieve $T_J = +150^\circ\text{C}$ minimum, and a minimum of $P_D = 75$ percent of $P_T$ as defined in <a href="#">1.3</a> . $n = 45$ , $c = 0$ . The sample size may be increased and the test time decreased as long as the devices are stressed for a total of 45,000 device hours minimum, and the actual time of test is at least 340 hours.
2	1048	Blocking life, $T_A = +150^\circ\text{C}$ , $V_{CB} = 80$ percent of rated voltage, 48 hours minimum. $n = 45$ devices, $c = 0$ .
3	1032	High- temperature life (non-operating), $T_A = +200^\circ\text{C}$ , $t = 340$ hours, $n = 22$ , $c = 0$ .

4.4.2.3 Group B sample selection. Samples selected from group B inspection shall meet all of the following requirements:

- a. For JAN, JANTX, and JANTXV samples shall be selected randomly from a minimum of three wafers (or from each wafer in the lot) from each wafer lot. For JANS, samples shall be selected from each inspection lot. See MIL-PRF-19500.
- b. Shall be chosen from an inspection lot that has been submitted to and passed [table I](#), subgroup 2, conformance inspection. When the final lead finish is solder or any plating prone to oxidation at high temperature, the samples for life test (subgroups B4 and B5 for JANS, and group B for JAN, JANTX, and JANTXV) may be pulled prior to the application of final lead finish.

4.4.3 Group C inspection. Group C inspection shall be conducted in accordance with the tests and conditions specified for subgroup testing in table E-VII of MIL-PRF-19500, and [4.4.3.1](#) (JANS), and [4.4.3.2](#) (JAN, JANTX, and JANTXV) herein for group C testing. Electrical measurements (end-points) and delta requirements shall be in accordance with [table I](#), subgroup 2 and [4.5.6](#) herein.

4.4.3.1 Group C inspection, table E-VII (JANS) of MIL-PRF-19500.

<u>Subgroup</u>	<u>Method</u>	<u>Condition</u>
C2	2036	Test condition E (not applicable to UB).
C5	3131	$R_{\theta JA}$ only, as applicable (see <a href="#">1.3</a> ) and in accordance thermal impedance curves on figures 6 and 7.
C6	1026	Steady-state life: 1,000 hours, $V_{CB} = 10$ V dc; power shall be applied to achieve $T_J = +150^\circ\text{C}$ minimum and a minimum of $P_D = 75$ percent of maximum rated $P_T$ as defined in <a href="#">1.3</a> $n = 45$ , $c = 0$ . The sample size may be increased and the test time decreased as long as the devices are stressed for a total of 45,000 device hours minimum, and the actual time of test is at least 340 hours.

4.4.3.2 Group C inspection, table E-VII (JAN, JANTX, and JANTXV) of MIL-PRF-19500.

<u>Subgroup</u>	<u>Method</u>	<u>Condition</u>
C2	2036	Test condition E (not applicable to UB).
C5	3131	$R_{\theta JA}$ only, as applicable (see <a href="#">1.3</a> ) and in accordance thermal impedance curves on figures 6 and 7.
C6	1037	Not applicable.

4.4.3.3 Group C sample selection. Samples for subgroups in group C shall be chosen at random from any inspection lot containing the intended package type and lead finish procured to the same specification which is submitted to and passes [table I](#) tests herein for conformance inspection. When the final lead finish is solder or any plating prone to oxidation at high temperature, the samples for C6 life test may be pulled prior to the application of final lead finish. Testing of a subgroup using a single device type enclosed in the intended package type shall be considered as complying with the requirements for that subgroup.

\* 4.4.4 Group D inspection. Conformance inspection for hardness assured JANS, and JANTXV types shall include the group D tests specified in [table II](#) herein. These tests shall be performed as required in accordance with MIL-PRF-19500 and method 1019 of MIL-STD-750, for total ionizing dose or method 1017 of MIL-STD-750 for neutron fluence as applicable (see [6.2](#) herein), except group D, subgroup 2 may be performed separate from other subgroups. Alternate package options may also be substituted for the testing provided there is no adverse effect to the fluence profile.

4.4.5 Group E inspection. Group E inspection shall be conducted in accordance with the conditions specified for subgroup testing in appendix E, table E-IX of MIL-PRF-19500 and as specified herein. Electrical measurements (end-points) and delta requirements shall be in accordance with [table I](#), subgroup 2 and [4.5.6](#) herein.

4.5 Methods of inspection. Methods of inspection shall be as specified in the appropriate tables and as follows.

4.5.1 Input capacitance. This test shall be conducted in accordance with method 3240 of MIL-STD-750, except the output capacitor shall be omitted.

4.5.2 Emitter to collector breakdown voltage. Method of test shall be in accordance with method 3011 of MIL-STD-750, test condition D, except that all references to the collector and the emitter of the transistor shall be interchanged.

4.5.3 Forward-current transfer ratio (inverted connection). Method of test shall be in accordance with method 3076 of MIL-STD-750, except that all references to the collector and the emitter of the transistor shall be interchanged in the test circuit. Then:  $h_{FE}(\text{inv}) = I_E / I_B$

4.5.4 Emitter to collector offset voltage. The transistor shall be tested in the circuit of [figure 8](#). The base current shall be adjusted to the specified value. The voltage between the emitter and collector shall then be measured using a voltmeter with an input impedance high enough that halving it does not change the measured value within the required accuracy of the measurement.

4.5.5 Small-signal emitter-collector on-state resistance. The transistor shall be tested in the circuit of [figure 9](#). The base current shall be adjusted to the specified value and an ac sinusoidal signal current,  $I_e$ , of the specified rms value shall be applied between the emitter and collector. The rms voltage,  $V_{ec}$ , between the emitter and collector shall be measured using an ac voltmeter with an input impedance high enough that halving it does not change the measured value within the required accuracy of the measurement. The small-signal emitter-collector on-state resistance shall then be determined as follows:

$$r_{ec}(\text{on}) = V_{ec} / I_e$$

Where  $V_{ec}$  is the rms voltage between the emitter and collector.

- \* 4.5.6 Delta requirements. Delta requirements shall be as specified below. (1) (2) (3) (4)

Step	Inspection	MIL-STD-750		Symbol	Limit	Unit
		Method	Conditions			
1	Collector to base cutoff current 2N2944A 2N2945A, AM, UB, and AUBM 2N2946A	3036	Bias condition D: $I_E = 0$ $V_{CB} = -15$ V dc $V_{CB} = -25$ V dc $V_{CB} = -40$ V dc	$\Delta I_{CBO1}$	100 percent of initial value or .2 nA .2 nA .5 nA	
2	Forward-current transfer ratio (inverted connection)	3076	$V_{EC} = -0.5$ V dc; $I_E = 200$ $\mu$ A dc; (see 4.5.3)	$\Delta h_{FE(inv)1}$	25 percent of initial value.	

- (1) The electrical measurements for table E-VIa (JANS) of MIL-PRF-19500 are as follows: Subgroup 5, see 4.5.6, steps 1 and 2.
- (2) The electrical measurements for 4.4.2.2 are as follows: See 4.5.6, steps 1 and 2.
- (3) The electrical measurements for table E-VII of MIL-PRF-19500 are as follows: Subgroup 6, step 1 and step 2 (JANS).
- \* (4) Group E table III herein, see 4.5.6, steps 1 and 2.

MIL-PRF-19500/382J

TABLE I. Group A inspection.

Inspection <u>1/</u>	MIL-STD-750		Symbol	Limits		Unit
	Method	Conditions		Min	Max	
<u>Subgroup 1 2/</u>						
Visual and mechanical <u>3/</u> examination	2071					
Solderability <u>3/ 4/</u>	2026	n = 15 leads, c = 0				
Resistance to <u>3/ 4/ 5/</u> solvent	1022	n = 15 devices, c = 0				
Temp cycling <u>3/ 4/</u>	1051	Test condition C, 25 cycles, n = 22 devices, c = 0				
Electrical measurements <u>4/</u>		<a href="#">Table I</a> , subgroup 2 herein				
Hermetic seal <u>4/ 6/</u>	1071	n = 22 devices, c = 0				
Fine leak Gross leak						
Bond strength <u>3/ 4/</u>	2037	Precondition T <sub>A</sub> = +250°C at t = 24 hrs or T <sub>A</sub> = +300°C at t = 2 hrs, n = 11 wires, c = 0				
Decap internal visual (design verification) <u>4/</u>	2075	n = 4 devices, c = 0				
<u>Subgroup 2</u>						
Thermal impedance	3131	See <a href="#">4.3.3</a>	Z <sub>θJX</sub>			°C/W
Breakdown voltage collector to emitter <u>7/</u>	3011	Bias condition D; I <sub>C</sub> = -10 μA dc	V <sub>(BR)CEO</sub>			
2N2944A, UB				-10		V dc
2N2945A, UB, UBM				-20		V dc
2N2946A, UB				-35		V dc
Collector to base cutoff current <u>7/</u>	3036	Bias condition D	I <sub>CBO1</sub>			
2N2944A, UB		V <sub>CB</sub> = -15 V dc			10	μA dc
2N2945A, UB, UBM		V <sub>CB</sub> = -25 V dc			10	μA dc
2N2946A, UB		V <sub>CB</sub> = -40 V dc			10	μA dc

See footnotes at the end of table.

TABLE I. Group A inspection - Continued.

Inspection <u>1</u> /	MIL-STD-750		Symbol	Limits		Unit
	Method	Conditions		Min	Max	
<u>Subgroup 2</u> - continued.						
Emitter to base cutoff current <u>7</u> / 2N2944A, UB 2N2945A, UB, UBM 2N2946A, UB	3061	Bias condition D  $V_{EB} = -15$ V dc $V_{EB} = -25$ V dc $V_{EB} = -40$ V dc	$I_{EBO1}$		10	$\mu$ A dc
Breakdown voltage, emitter to collector <u>7</u> / 2N2944A, UB 2N2945A, UB, UBM 2N2946A, UB	3011	Bias condition B; $I_E = -10$ $\mu$ A dc; $I_B = 0$ ; (see 4.5.2)	$V_{(BR)ECO}$	-10 -20 -35		V dc V dc V dc
Collector to base cutoff current <u>7</u> / 2N2944A, UB 2N2945A, UB, UBM 2N2946A, UB	3036	Bias condition D  $V_{CB} = -12$ V dc $V_{CB} = -20$ V dc $V_{CB} = -32$ V dc	$I_{CBO2}$		-0.1 -0.2 -0.5	nA dc nA dc nA dc
Emitter to base cutoff current <u>7</u> / 2N2944A, UB 2N2945A, UB, UBM 2N2946A, UB	3061	Bias condition D  $V_{EB} = -12$ V dc $V_{EB} = -20$ V dc $V_{EB} = -32$ V dc	$I_{EBO2}$		-0.1 -0.2 -0.5	nA dc nA dc nA dc
Forward-current transfer ratio <u>7</u> / 2N2944A, UB 2N2945A, UB 2N2945AM, UBM 2N2946A, UB	3076	$V_{CE} = -0.5$ V dc; $I_C = -1.0$ mA dc	$h_{FE1}$	100 70 70 50	200	
Forward-current transfer ratio (inverted connection) <u>7</u> / 2N2944A, UB 2N2945A, UB, UBM 2N2946A, UB	3076	$V_{EC} = -0.5$ V dc; $I_E = -200$ $\mu$ A dc (see 4.5.3)	$h_{FE} (inv)_1$	50 30 20		

See footnotes at the end of table.

TABLE I. Group A inspection - Continued.

Inspection <u>1</u> /	MIL-STD-750		Symbol	Limits		Unit
	Method	Conditions		Min	Max	
<u>Subgroup 2</u> - continued.						
Emitter to collector offset voltage <u>7</u> / 2N2944A, UB 2N2945A, UB, UBM 2N2946A, UB		$I_B = -200 \mu\text{A dc}; I_E = 0;$ (see 4.5.4 and figure 8)	$V_{EC} (\text{ofs})_1$		-0.3 -0.5 -0.8	mV dc mV dc mV dc
Emitter to collector offset voltage <u>7</u> / 2N2944A, UB 2N2945A, UB, UBM 2N2946A, UB		$I_B = -1 \text{ mA dc}; I_E = 0;$ (see 4.5.4 and figure 8)	$V_{EC} (\text{ofs})_2$		-0.6 -1.0 -2.0	mV dc mV dc mV dc
Emitter to collector offset voltage <u>7</u> / 2N2944A, UB 2N2945A, UB, UBM 2N2946A, UB		$I_B = -2 \text{ mA dc}; I_E = 0;$ (see 4.5.4 and figure 8)	$V_{EC} (\text{ofs})_3$		-1.0 -1.6 -2.5	mV dc mV dc mV dc
<u>Subgroup 3</u>						
High-temperature operation:		$T_A = +100^\circ\text{C}$				
Collector to base cutoff current <u>7</u> / 2N2944A, UB 2N2945A, UB, UBM 2N2946A, UB	3036	Bias condition D; $I_C = 0$  $V_{CB} = -15 \text{ V dc}$ $V_{CB} = -25 \text{ V dc}$ $V_{CB} = -40 \text{ V dc}$	$I_{CBO3}$		10 20 25	nA dc nA dc nA dc
Emitter to base cutoff current <u>7</u> / 2N2944A, UB 2N2945A, UB, UBM 2N2946A, UB	3061	Bias condition D; $I_C = 0$  $V_{CB} = -15 \text{ V dc}$ $V_{CB} = -25 \text{ V dc}$ $V_{CB} = -40 \text{ V dc}$	$I_{EBO3}$		10 15 20	nA dc nA dc nA dc

See footnotes at the end of table.

TABLE I. Group A inspection - Continued.

Inspection <u>1/</u>	MIL-STD-750		Symbol	Limits		Unit
	Method	Conditions		Min	Max	
<u>Subgroup 3</u> – continued.						
Low-temperature operation:		$T_A = -55^\circ\text{C}$				
Forward-current transfer ratio <u>Z/</u>	3+076	$V_{CE} = -0.5\text{ V dc};$ $I_C = -1\text{ mA dc}$	$h_{FE2}$	35 25 20		
2N2944A, UB 2N2945A, UB, UBM 2N2946A, UB						
Forward-current transfer ratio (inverted connection) <u>Z/</u>	3076	$V_{EC} = -0.5\text{ V dc};$ $I_E = -200\text{ }\mu\text{A dc}$ (see 4.5.3)	$h_{FE}(\text{inv})_2$	25 15 10		
2N2944A, UB 2N2945A, UB, UBM 2N2946A, UB						
<u>Subgroup 4</u>						
Small-signal emitter-collector on-state resistance <u>Z/</u>		$I_B = -100\text{ }\mu\text{A dc}; I_E = 0;$ $I_e = 100\text{ }\mu\text{A ac (rms)}$ $f = 1\text{ kHz}$ (see 4.5.5 and figure 9)	$r_{ec}(\text{on})_1$		10 12 14	ohm ohm ohm
2N2944A, UB 2N2945A, UB, UBM 2N2946A, UB						
Small-signal emitter-collector on-state resistance <u>Z/</u>		$I_B = -1\text{ mA dc}; I_E = 0;$ $I_e = 100\text{ }\mu\text{A ac (rms)}$ $f = 1\text{ kHz}$ (see 4.5.5 and figure 9)	$r_{ec}(\text{on})_2$		4 6 8	ohm ohm ohm
2N2944A, UB 2N2945A, UB, UBM 2N2946A, UB						

See footnotes at the end of table.



TABLE I. Group A inspection - Continued.

Inspection <u>1/</u>	MIL-STD-750		Symbol	Limits		Unit
	Method	Conditions		Min	Max	
<u>Subgroup 4</u> – continued.						
Magnitude of common-emitter small-signal short-circuit forward-current transfer ratio <u>7/</u>		$V_{CE} = -6 \text{ V dc};$ $I_C = -1 \text{ mA dc};$ $f = 1 \text{ MHz}$	$ h_{fe} $			
2N2944A, UB				15	55	
2N2945A, UB				10	55	
2N2946A, UB				5	55	
Open circuit output capacitance	3236	$V_{CB} = -6 \text{ V dc}; I_E = 0;$ $100 \text{ kHz} \leq f \leq 1 \text{ MHz}$	$C_{obo}$		10	pF
Input capacitance (output open-circuited)	3240	$V_{EB} = -6 \text{ V dc}; I_C = 0;$ $100 \text{ kHz} \leq f \leq 1 \text{ MHz}$ (see 4.5.1)	$C_{ibo}$		6.0	pF
Pulse response:						
Delay time	3251	Test condition B (see figure 10)	$t_d$		50	ns
Rise time	3251	Test condition B (see figure 10)	$t_r$		100	ns
Storage time	3251	Test condition B (see figure 10)	$t_s$		350	ns
Fall time	3251	Test condition B (see figure 10)	$t_f$		100	ns
<u>Subgroups 5, and 6</u>						
Not applicable						

1/ For sampling plan, see MIL-PRF-19500.

2/ For resubmission of failed subgroup 1, double the sample size of the failed test or sequence of tests.

3/ Separate samples may be used.

4/ Not required for JANS.

5/ Not required for laser marked devices.

6/ Hermetic seal test is an end-point to temperature cycling in addition to electrical measurements.

7/ 2N2945AM and 2N2945AUBM shall meet all other requirements as specified in accordance with table I for 2N2945A and 2N2945AUB.

MIL-PRF-19500/382J

\* TABLE II. Group D inspection.

Inspection <u>1/ 2/ 3/</u>	MIL-STD-750		Symbol	Limits		Unit
	Method	Conditions		Min	Max	
<u>Subgroup 1 4/</u>						
Neutron irradiation	1017	Neutron exposure $V_{CES} = 0$ V				
Breakdown voltage collector to emitter 2N2944A, UB 2N2945A, UB, UBM 2N2946A, UB	3011	Bias condition D $I_C = -10 \mu\text{A dc}$	$V_{(BR)ECO}$	-10 -20 -35		V dc V dc V dc
Collector to base cutoff current 2N2944A, UB 2N2945A, UB, UBM 2N2946A, UB	3036	Bias condition D $V_{CB} = -15$ V dc $V_{CB} = -25$ V dc $V_{CB} = -40$ V dc	$I_{CBO1}$		20 20 20	$\mu\text{A dc}$ $\mu\text{A dc}$ $\mu\text{A dc}$
Emitter to base cutoff current 2N2944A, UB 2N2945A, UB, UBM 2N2946A, UB	3061	Bias condition D $V_{BE} = -15$ V dc $V_{BE} = -25$ V dc $V_{BE} = -40$ V dc	$I_{EBO1}$		20 20 20	$\mu\text{A dc}$ $\mu\text{A dc}$ $\mu\text{A dc}$
Breakdown voltage emitter to collector 2N2944A, UB 2N2945A, UB, UBM 2N2946A, UB	3011	Bias condition $\text{D B}$ ; $I_E = -10 \mu\text{A dc}$ ; $I_B = 0$ mA dc, pulsed (see 4.5.2)	$V_{(BR)ECO}$	-10 -20 -35		V dc V dc V dc
Collector to base cutoff current 2N2944A, UB 2N2945A, UB, UBM 2N2946A, UB	3036	Bias condition D; $V_{CB} = -12$ V dc $V_{CB} = -20$ V dc $V_{CB} = -32$ V dc	$I_{EBO2}$		-0.2 -0.4 -1.0	$\eta\text{A dc}$ $\eta\text{A dc}$ $\eta\text{A dc}$
Emitter to base cutoff current 2N2944A, UB 2N2945A, UB, UBM 2N2946A, UB	3061	Bias condition D; $V_{CB} = -12$ V dc $V_{CB} = -20$ V dc $V_{CB} = -32$ V dc	$I_{CBO2}$		-0.2 -0.4 -1.0	$\eta\text{A dc}$ $\eta\text{A dc}$ $\eta\text{A dc}$
Forward-current transfer ratio 2N2944A, UB 2N2945A, UB 2N2945AM, UBM 2N2946A, UB	3076	$V_{CE} = -0.5$ V dc, $I_C = -1.0$ mA dc	$[h_{FE1}]$	$\frac{5}{[50]}$ $\frac{5}{[35]}$ $\frac{5}{[35]}$ $\frac{5}{[25]}$	200	
Forward-current transfer ratio 2N2944A, UB 2N2945A, UB, UBM 2N2946A, UB	3076	$V_{EC} = -0.5$ V dc, $I_C = -200 \mu\text{A dc}$ ; pulsed (see 4.5.1)	$[h_{FE(inv)}]_1$	$\frac{5}{[25]}$ $\frac{5}{[15]}$ $\frac{5}{[10]}$		

See footnotes at end of table.

\* TABLE II. Group D inspection. - Continued.

Inspection 1/ 2/ 3/	MIL-STD-750		Symbol	Limits		Unit
	Method	Conditions		Min	Max	
<u>Subgroup 1 4/</u> - Continued						
Emitter to collector offset voltage 2N2944A, UB 2N2945A, UB, UBM 2N2946A, UB	3071	$I_B = -200 \mu\text{A dc}$ , $I_E = 0$ , pulsed (see 4.5.4 and figure 8)	$V_{EC(ofs)1}$		-0.5 -0.8 -1.2	mV dc mV dc mV dc
Emitter to collector offset voltage 2N2944A, UB 2N2945A, UB, UBM 2N2946A, UB	3071	$I_B = -1.0 \text{ mA dc}$ , $I_E = 0$ pulsed (see 4.5.4 and figure 8)	$V_{EC(ofs)2}$		-0.9 -1.5 -3.0	mV dc mV dc mV dc
Emitter to collector offset voltage 2N2944A, UB 2N2945A, UB, UBM 2N2946A, UB	3071	$I_B = -2.0 \text{ mA dc}$ , $I_E = 0$ pulsed (see 4.5.4 and figure 8)	$V_{EC(ofs)3}$		-1.5 -2.4 -3.8	mV dc mV dc mV dc
<u>Subgroup 2 4/</u>						
Steady-state total dose irradiation	1019	Gamma exposure $V_{ECS} = -8 \text{ V}$ Gamma exposure $V_{ECS} = -16 \text{ V}$ Gamma exposure $V_{ECS} = -28 \text{ V}$				
Breakdown voltage collector to emitter 2N2944A, UB 2N2945A, UB, UBM 2N2946A, UB	3011	Bias condition D $I_C = -10 \mu\text{A dc}$	$V_{(BR)ECO}$	-10 -20 -35		V dc V dc V dc
Collector to base cutoff current 2N2944A, UB 2N2945A, UB, UBM 2N2946A, UB	3036	Bias condition D $V_{CB} = -15 \text{ V dc}$ $V_{CB} = -25 \text{ V dc}$ $V_{CB} = -40 \text{ V dc}$	$I_{CBO1}$		20 20 20	$\mu\text{A dc}$ $\mu\text{A dc}$ $\mu\text{A dc}$
Emitter to base cutoff current 2N2944A, UB 2N2945A, UB, UBM 2N2946A, UB	3061	Bias condition D $V_{BE} = -15 \text{ V dc}$ $V_{BE} = -25 \text{ V dc}$ $V_{BE} = -40 \text{ V dc}$	$I_{EBO1}$		20 20 20	$\mu\text{A dc}$ $\mu\text{A dc}$ $\mu\text{A dc}$
Breakdown voltage emitter to collector 2N2944A, UB 2N2945A, UB, UBM 2N2946A, UB	3011	Bias condition B; $I_E = -10 \mu\text{A dc}$ ; $I_B = 0 \text{ mA dc}$ , pulsed (see 4.5.2)	$V_{(BR)ECO}$	-10 -20 -35		V dc V dc V dc

See footnotes at end of table.

\* TABLE II. Group D inspection. - Continued.

Inspection <u>1/</u> <u>2/</u> <u>3/</u>	MIL-STD-750		Symbol	Limits		Unit
	Method	Conditions		Min	Max	
<u>Subgroup 2 4/</u> - Continued.						
Collector to base cutoff current 2N2944A, UB 2N2945A, UB, UBM 2N2946A, UB	3036	Bias condition D  $V_{CB} = -12$ V dc $V_{CB} = -20$ V dc $V_{CB} = -32$ V dc	$I_{CBO2}$		-0.2 -0.4 -1.0	$\eta$ A dc $\eta$ A dc $\eta$ A dc
Emitter to base cutoff current 2N2944A, UB 2N2945A, UB, UBM 2N2946A, UB	3061	Bias condition D  $V_{CB} = -12$ V dc $V_{CB} = -20$ V dc $V_{CB} = -32$ V dc	$I_{EBO2}$		-0.2 -0.4 -1.0	$\eta$ A dc $\eta$ A dc $\eta$ A dc
Forward-current transfer ratio 2N2944A, UB 2N2945A, UB 2N2945AM, UBM 2N2946A, UB	3076	$V_{CE} = -0.5$ V dc, $I_C = -1.0$ mA dc	$[h_{FE1}]$	$\frac{5}{5}$ [50] $\frac{5}{5}$ [35] $\frac{5}{5}$ [35] $\frac{5}{5}$ [25]	200	
Forward-current transfer ratio 2N2944A, UB 2N2945A, UB, UBM 2N2946A, UB	3076	$V_{EC} = -0.5$ V dc, $I_C = -200$ $\mu$ A dc; pulsed (see 4.5.1)	$[h_{FE(inv)}]_1$	$\frac{5}{5}$ [25] $\frac{5}{5}$ [15] $\frac{5}{5}$ [10]		
Emitter to collector offset voltage 2N2944A, UB 2N2945A, UB, UBM 2N2946A, UB		$I_B = -200$ $\mu$ A dc, $I_E = 0$ , pulsed (see 4.5.4 and figure 8)	$V_{EC(ofs)1}$		-0.5 -0.8 -1.2	mV dc mV dc mV dc
Emitter to collector offset voltage 2N2944A, UB 2N2945A, UB, UBM 2N2946A, UB		$I_B = -1.0$ mA dc, $I_E = 0$ pulsed (see 4.5.4 and figure 8)	$V_{EC(ofs)2}$		-0.9 -1.5 -3.0	mV dc mV dc mV dc
Emitter to collector offset voltage 2N2944A, UB 2N2945A, UB, UBM 2N2946A, UB		$I_B = -2.0$ mA dc, $I_E = 0$ pulsed (see 4.5.4 and figure 8)	$V_{EC(ofs)3}$		-1.5 -2.4 -3.8	mV dc mV dc mV dc

1/ Tests to be performed on all devices receiving radiation exposure.

2/ For sampling plan, see MIL-PRF-19500.

3/ Electrical characteristics apply to all device types unless otherwise noted.

4/ See 6.2.e herein.

5/ See method 1019 of MIL-STD-750, for how to determine  $[h_{FE}]$  by first calculating the  $\Delta(1/h_{FE})$  from the pre- and post-radiation  $h_{FE}$ . Notice that  $[h_{FE}]$  is not the same as  $h_{FE}$  and cannot be measured directly. The  $[h_{FE}]$  value can never exceed the pre-radiation minimum  $h_{FE}$  that it is based upon.

MIL-PRF-19500/382J

\* TABLE III. Group E inspection (all quality levels) – for qualification or re-qualification only.

Inspection	MIL-STD-750		Qualification
	Method	Conditions	
<u>Subgroup 1</u>			45 devices c = 0
Temperature cycling (air to air)	1051	Test condition C, 500 cycles	
Hermetic seal			
Fine leak Gross leak	1071		
Electrical measurements		See <a href="#">table I</a> , subgroup 2 and <a href="#">4.5.6</a> herein.	
<u>Subgroup 2</u>			45 devices c = 0
Intermittent life	1037	$V_{CB} = 10 \text{ V dc}$ , $t_{on} = t_{off} = 3 \text{ minutes minimum}$ $P_t = 400 \text{ mW}$ , 6,000 cycles.	
Electrical measurements		See <a href="#">table I</a> , subgroup 2 and <a href="#">4.5.6</a> herein.	
<u>Subgroup 4</u>			15 devices c = 0
Thermal resistance	3131	$R_{\theta JSP}$ can be calculated but shall be measured once in the same package with a similar die size to confirm calculations (may apply to multiple specification sheets).	
Thermal resistance curves		See MIL-PRF-19500.	Sample size N/A
<u>Subgroup 5</u>			
Not applicable			
<u>Subgroup 6</u>			
ESD	1020		
<u>Subgroup 8</u>			45 devices c = 0
Reverse stability	1033	Condition B.	

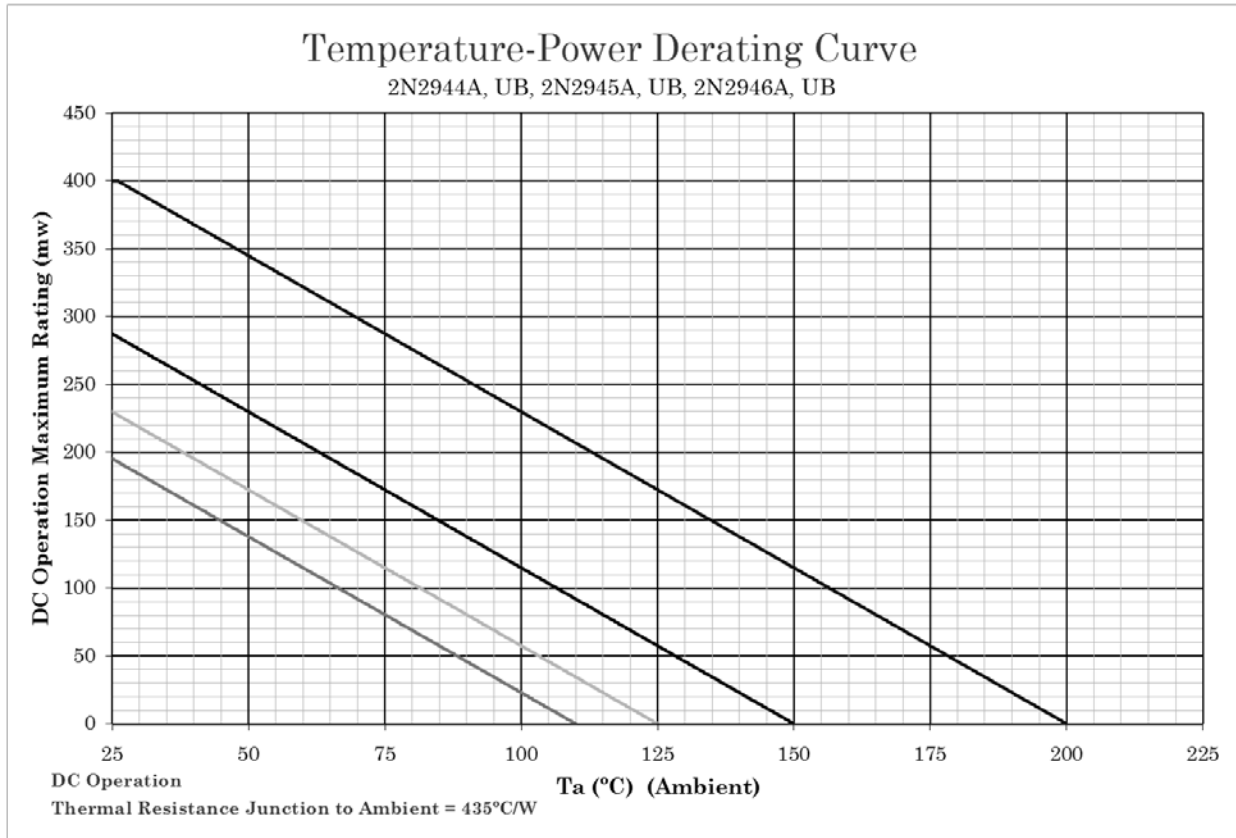

## NOTES:

1. All devices are capable of operating at  $\leq T_J$  specified on this curve. Any parallel line to this curve will intersect the appropriate power for the desired maximum  $T_J$  allowed.
2. Derate design curve constrained by the maximum junction temperature ( $T_J \leq 200^\circ\text{C}$ ) and power rating specified. (See 1.3 herein.)
3. Derate design curve chosen at  $T_J \leq 150^\circ\text{C}$ , where the maximum temperature of electrical test is performed.
4. Derate design curves chosen at  $T_J \leq 125^\circ\text{C}$ , and  $110^\circ\text{C}$  to show power rating where most users want to limit  $T_J$  in their application.

FIGURE 4. Derating for 2N2944A, 2N2944AUB, 2N2945A, 2N2945AUB, 2N2946A, and 2N2946AUB ( $R_{\theta JA}$ ), base case mounted (TO-46 and UB).

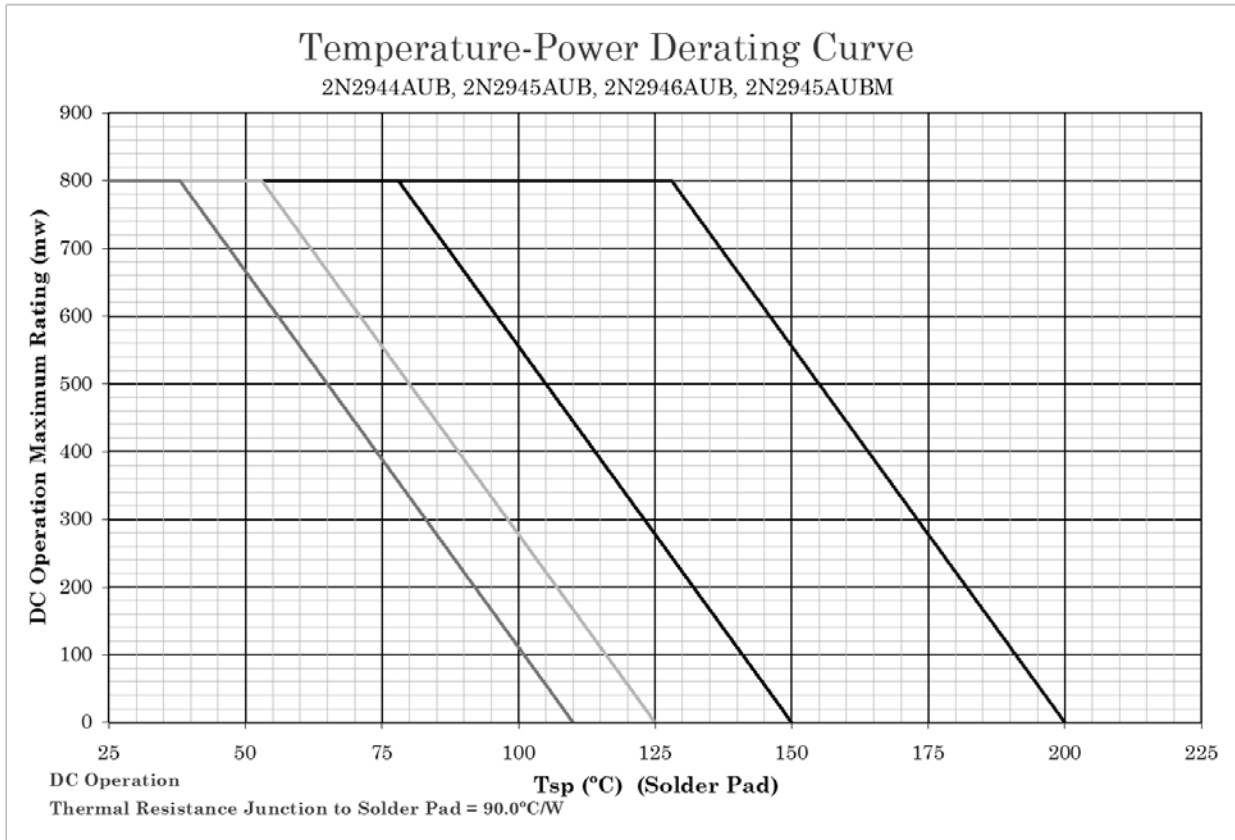
**NOTES:**

1. All devices are capable of operating at  $\leq T_J$  specified on this curve. Any parallel line to this curve will intersect the appropriate power for the desired maximum  $T_J$  allowed.
2. Derate design curve constrained by the maximum junction temperature ( $T_J \leq 200^\circ\text{C}$ ) and power rating specified. (See 1.3 herein.)
3. Derate design curve chosen at  $T_J \leq 150^\circ\text{C}$ , where the maximum temperature of electrical test is performed.
4. Derate design curves chosen at  $T_J \leq 125^\circ\text{C}$ , and  $110^\circ\text{C}$  to show power rating where most users want to limit  $T_J$  in their application.

FIGURE 5. Derating for 2N2944AUB, 2N2945AUB, 2N2945AUBM, and 2N2946AUB ( $R_{\theta JSP}$ ), base case mounted (UB).

**Maximum Thermal Impedance**

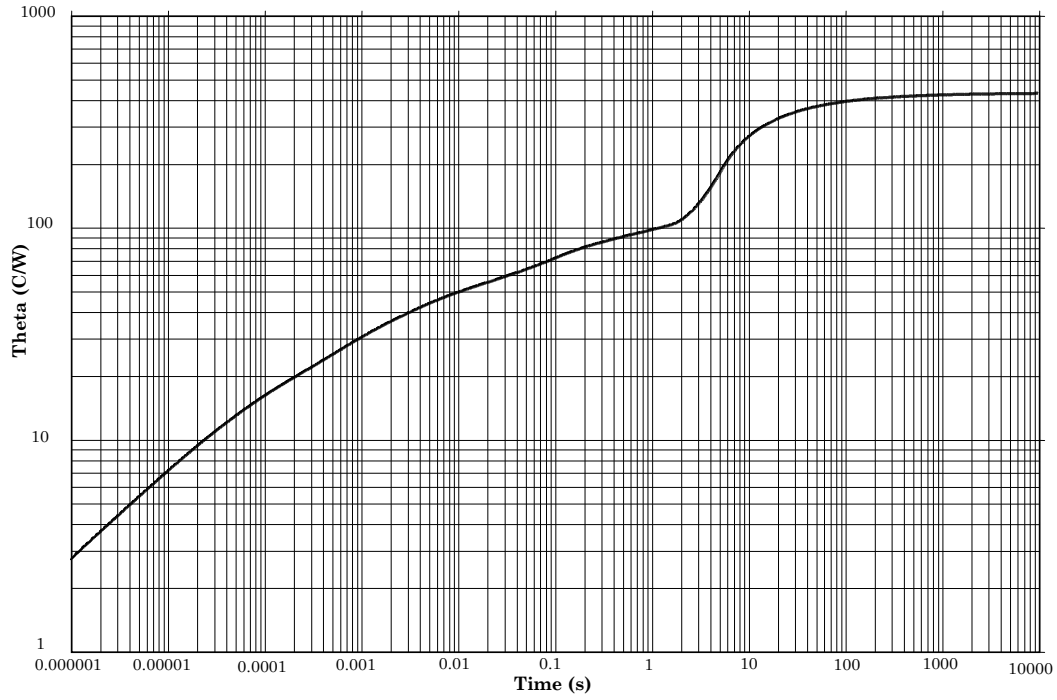

TO-46 free air  $T_A = +25^\circ\text{C}$  with 16 x 23 mil chip.

$T_A = +25^\circ\text{C}$ ,  $P_{\text{diss}} = 400 \text{ mW}$ ,  $435^\circ\text{C/W}$  (ambient thermal resistance varies with power).

FIGURE 6. Thermal impedance graph ( $R_{\theta\text{JA}}$ ) for (TO-46).



**Maximum Thermal Impedance**

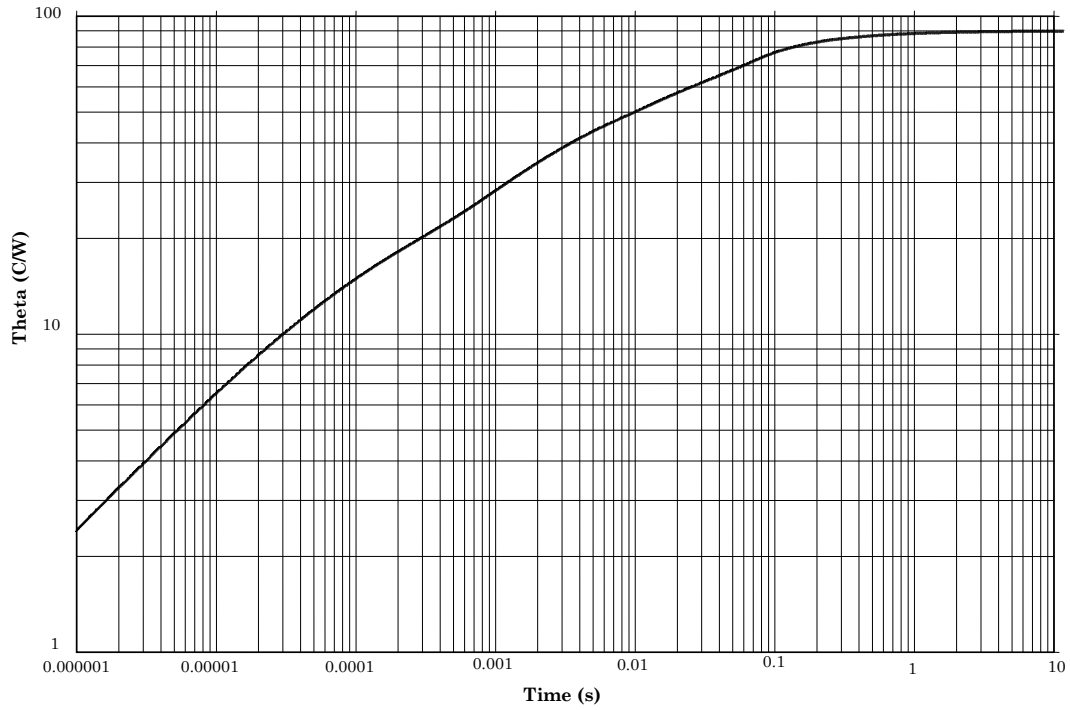

Thermal resistance = 90°C/W

Solder mounted to heavy copper clad PCB at  $T_C = +25^\circ\text{C}$ .

FIGURE 7. Thermal impedance graph (UB).

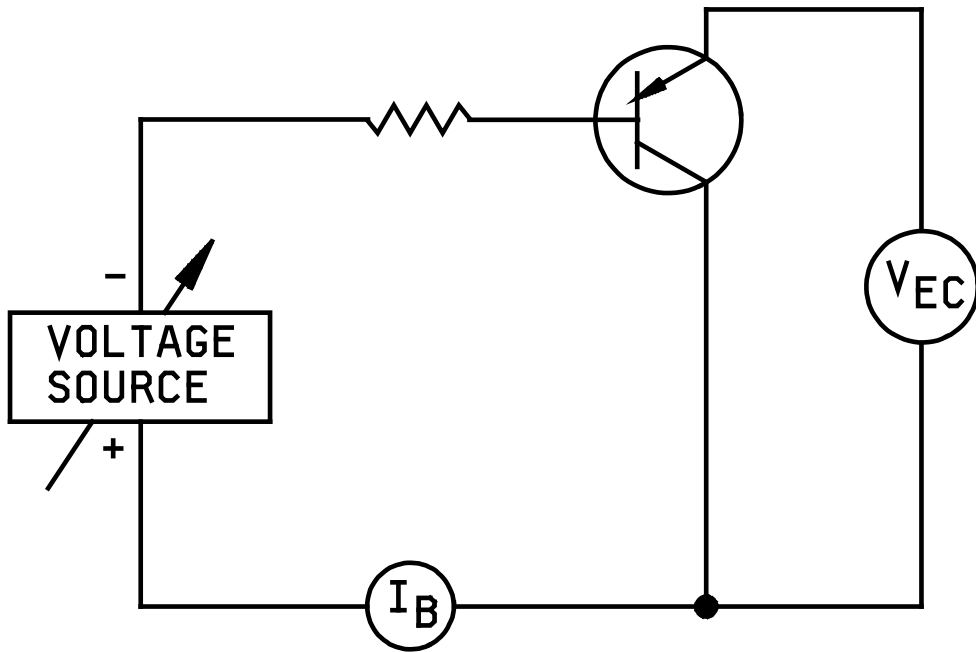

FIGURE 8. Emitter to collector offset voltage test circuit.

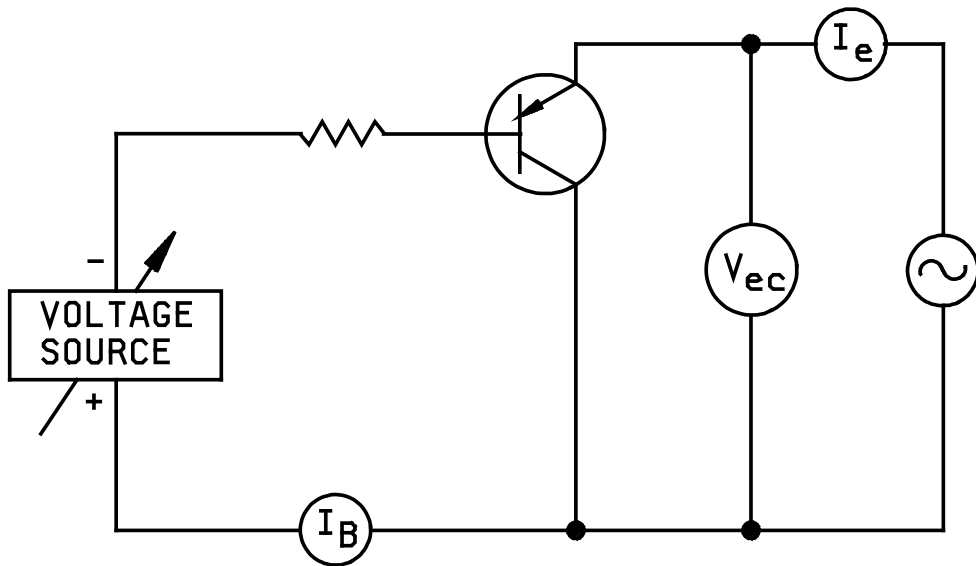
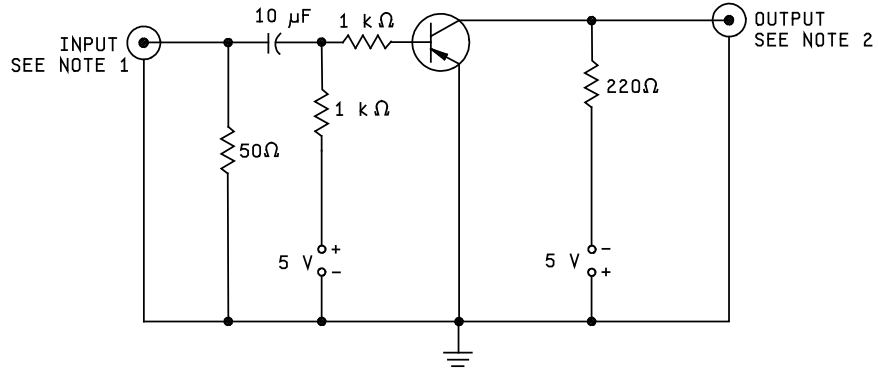
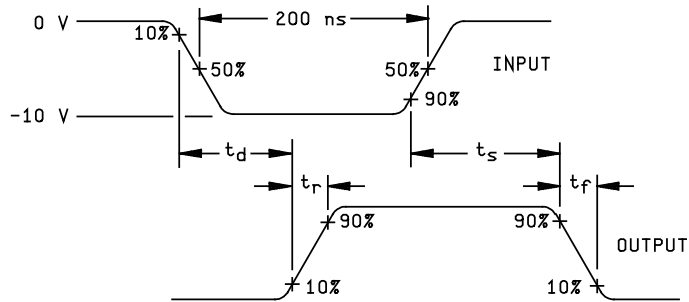

FIGURE 9. Small-signal emitter to collector on set voltage test circuit.



TEST CIRCUIT



VOLTAGE WAVEFORMS

NOTES:

1. The rise time ( $t_r$ ) and fall time ( $t_f$ ) of the applied pulse shall be  $\leq 10$  ns, duty cycle  $\leq 2$  percent. The input pulse width shall be 200 ns.
2. Output monitored with an oscilloscope with the following characteristics:  $Z_{in} \leq 1$  M $\Omega$ ,  $t_r \leq 1$  ns.

FIGURE 10. Pulse response test circuit.

## 5. PACKAGING

5.1 Packaging. For acquisition purposes, the packaging requirements shall be as specified in the contract or order (see 6.2). When packaging of materiel is to be performed by DoD or in-house contractor personnel, these personnel need to contact the responsible packaging activity to ascertain packaging requirements. Packaging requirements are maintained by the Inventory Control Point's packaging activities within the Military Service or Defense Agency, or within the Military Service's system commands. Packaging data retrieval is available from the managing Military Department's or Defense Agency's automated packaging files, CD-ROM products, or by contacting the responsible packaging activity.

## 6. NOTES

(This section contains information of a general or explanatory nature that may be helpful, but is not mandatory. The notes specified in MIL-PRF-19500 are applicable to this specification.)

- \* 6.1 Intended use. Semiconductors conforming to this specification are intended for original equipment design applications and logistic support of existing equipment.
- \* 6.2 Acquisition requirements. Acquisition documents should specify the following:
  - a. Title, number, and date of this specification.
  - b. Packaging requirements (see 5.1).
  - c. Lead finish (see 3.4.1).
  - d. Product assurance level and type designator.
- \* e. For acquisition of RHA designed devices, [table II](#), subgroup 1 testing of group D is optional. If subgroup 1 testing is desired, it should be specified in the contract.
- \* 6.3 Qualification. With respect to products requiring qualification, awards will be made only for products which are, at the time of award of contract, qualified for inclusion in Qualified Manufacturers List (QML 19500) whether or not such products have actually been so listed by that date. The attention of the contractors is called to these requirements, and manufacturers are urged to arrange to have the products that they propose to offer to the Federal Government tested for qualification in order that they may be eligible to be awarded contracts or orders for the products covered by this specification. Information pertaining to qualification of products may be obtained from DLA Land and Maritime, ATTN: VQE, P.O. Box 3990, Columbus, OH 43218-3990 or e-mail [vqe.chief@dla.mil](mailto:vqe.chief@dla.mil). An online listing of products qualified to this specification may be found in the Qualified Products Database (QPD) at <https://assist.daps.dla.mil>.
- 6.4 Suppliers of JANHC and JANKC die. The qualified JANHC and JANKC suppliers with the applicable letter version (example JANHCA2N2945) will be identified on the QML.

Die ordering information	
PIN	Manufacturer
2N2944A	JANHCA2N2944A, JANKCA2N2944A
2N2945A	JANHCA2N2945A, JANKCA2N2945A
2N2946A	JANHCA2N2946A, JANKCA2N2946A

6.5 Changes from previous issue. The margins of this specification are marked with asterisks to indicate where changes from the previous issue were made. This was done as a convenience only and the Government assumes no liability whatsoever for any inaccuracies in these notations. Bidders and contractors are cautioned to evaluate the requirements of this document based on the entire content irrespective of the marginal notations and relationship to the last previous issue.

Custodians:

Army - CR  
Navy - EC  
Air Force - 85  
NASA - NA  
DLA - CC

Preparing activity:

DLA - CC

(Project 5961-2012-001)

Review activities:

Army - AV, MI  
Air Force - 19, 71, 99

NOTE: The activities listed above were interested in this document as of the date of this document. Since organizations and responsibilities can change, you should verify the currency of the information above using the ASSIST Online database at <https://assist.daps.dla.mil>.