

The documentation and process conversion measures necessary to comply with this document shall be completed by 1 August 2012.

INCH-POUND

MIL-PRF-19500/343K  
1 MAY 2012  
SUPERSEDING  
MIL-PRF-19500/343J  
2 April 2010

PERFORMANCE SPECIFICATION SHEET

SEMICONDUCTOR DEVICE, TRANSISTOR, NPN, SILICON, LOW POWER, TYPES 2N2857 AND 2N2857UB, JAN, JANTX, JANTXV, AND JANS, JANSM, JANSJ, JANSR, JANSL, JANSR, JANHCF, JANHCG, JANSJ, JANHC, AND JANKC

This specification is approved for use by all Departments and Agencies of the Department of Defense.

The requirements for acquiring the product described herein shall consist of this specification sheet and MIL-PRF-19500.

1. SCOPE

1.1 Scope. This specification covers the performance requirements for NPN, silicon, low power, ultra-high frequency transistors. Four levels of product assurance are provided for each device type. Two levels of product assurance are provided for unencapsulated devices as specified in MIL-PRF-19500. RHA level designators "M", "D", "P", "L", "R", "F", "G", and "H" are appended to the device prefix to identify devices, which have passed RHA requirements.

1.2 Physical dimensions. See [figure 1](#) (TO-72), [figure 2](#) (UB surface mount), and [figure 3](#) (JANHC, JANKC die).

\* 1.3 Maximum ratings at  $T_A = +25^\circ\text{C}$  unless otherwise specified.

	$P_T$ $T_A = +25^\circ\text{C}$	$P_T$ (1) $T_C = +25^\circ\text{C}$	$I_C$	$V_{CBO}$	$V_{CEO}$	$V_{EBO}$	$R_{\theta JA}$ (2)	$R_{\theta JSP}$ (2)	$R_{\theta JC}$ (2)	$T_J$ and $T_{STG}$
	<u>mW</u>	<u>mW</u>	<u>mA dc</u>	<u>V dc</u>	<u>V dc</u>	<u>V dc</u>	<u>°C/W</u>	<u>°C/W</u>	<u>°C/W</u>	<u>°C</u>
TO-72	200	300	40	30	15	3	550		300	-65 to +200
UB	200	300	40	30	15	3	350	210	130	

(1) Derate linearly 1.71 mW/°C for  $T_C > +25^\circ\text{C}$ .

\* (2) For thermal impedance curves, see figures 4, 5, and 6.

\* Comments, suggestions, or questions on this document should be addressed to DLA Land and Maritime, ATTN: VAC, P.O. Box 3990, Columbus, OH 43218-3990, or emailed to [Semiconductor@dla.mil](mailto:Semiconductor@dla.mil). Since contact information can change, you may want to verify the currency of this address information using the ASSIST Online database at <https://assist.daps.dla.mil>.

1.4 Primary electrical characteristics at  $T_A = +25^\circ\text{C}$ .

	$h_{FE1}$	$ h_{fe} $	$C_{cb}$	F	$G_{pe}$	$r_b' C_c$
	$V_{CE} = 1 \text{ V dc}$ $I_C = 3 \text{ mA dc}$	$V_{CE} = 6 \text{ V dc}$ $I_C = 5 \text{ mA dc}$ $f = 100 \text{ MHz}$	$V_{CB} = 10 \text{ V dc}$ $I_E = 0$ $f = 100 \text{ kHz} \leq f$ $\leq 1 \text{ MHz}$	$V_{CE} = 6 \text{ V dc}$ $I_C = 1.5 \text{ mA dc}$ $f = 450 \text{ MHz}$ $R_g = 50 \Omega$	$V_{CE} = 6 \text{ V dc}$ $I_C = 1.5 \text{ mA dc}$ $f = 450 \text{ MHz}$	$V_{CB} = 6 \text{ V dc}$ $I_E = 2 \text{ mA dc}$ $f = 31.9 \text{ MHz}$
Min	30	10	pf	db	db	ps
Max	150	21	1.0	4.5	12.5 21	4 15

2. APPLICABLE DOCUMENTS

2.1 General. The documents listed in this section are specified in sections 3, 4, or 5 of this specification. This section does not include documents cited in other sections of this specification or recommended for additional information or as examples. While every effort has been made to ensure the completeness of this list, document users are cautioned that they must meet all specified requirements of documents cited in sections 3, 4, or 5 of this specification, whether or not they are listed.

2.2 Government documents.

2.2.1 Specifications, standards, and handbooks. The following specifications, standards, and handbooks form a part of this document to the extent specified herein. Unless otherwise specified, the issues of these documents are those cited in the solicitation or contract.

DEPARTMENT OF DEFENSE SPECIFICATIONS

MIL-PRF-19500 - Semiconductor Devices, General Specification for.

DEPARTMENT OF DEFENSE STANDARDS

MIL-STD-750 - Test Methods for Semiconductor Devices.

(Copies of these documents are available online at <https://assist.daps.dla.mil/quicksearch> or <https://assist.daps.dla.mil> or from the Standardization Document Order Desk, 700 Robbins Avenue, Building 4D, Philadelphia, PA 19111-5094.)

2.3 Order of precedence. Unless otherwise noted herein or in the contract, in the event of a conflict between the text of this document and the references cited herein, the text of this document takes precedence. Nothing in this document, however, supersedes applicable laws and regulations unless a specific exemption has been obtained.

3. REQUIREMENTS

3.1 General. The individual item requirements shall be as specified in MIL-PRF-19500 and as modified herein.

3.2 Qualification. Devices furnished under this specification shall be products that are manufactured by a manufacturer authorized by the qualifying activity for listing on the applicable qualified manufacturers list before contract award (see 4.2 and 6.3).

3.3 Abbreviations, symbols, and definitions. Abbreviations, symbols, and definitions used herein shall be as specified in MIL-PRF-19500.

3.4 Interface and physical dimensions. Interface and physical dimensions shall be as specified in MIL-PRF-19500, and on figures 1, 2, and 3.

Symbol	Dimensions				Notes
	Inches		Millimeters		
	Min	Max	Min	Max	
CD	.178	.195	4.52	4.95	5
CH	.170	.210	4.32	5.33	
HD	.209	.230	5.31	5.84	5
LC	.100 TP		2.54 TP		7,8
LD	.016	.021	.410	.533	7,8
LL	.500	.750	12.70	19.05	7,8
LU	.016	.019	.41	.48	
L <sub>1</sub>		.050		1.27	
L <sub>2</sub>	.250		6.35		
P	.100		2.54		
Q		.040		1.02	5
TL	.028	.048	.71	1.22	
TW	.036	.046	.91	1.17	
r		.007		.18	
α	45° TP				

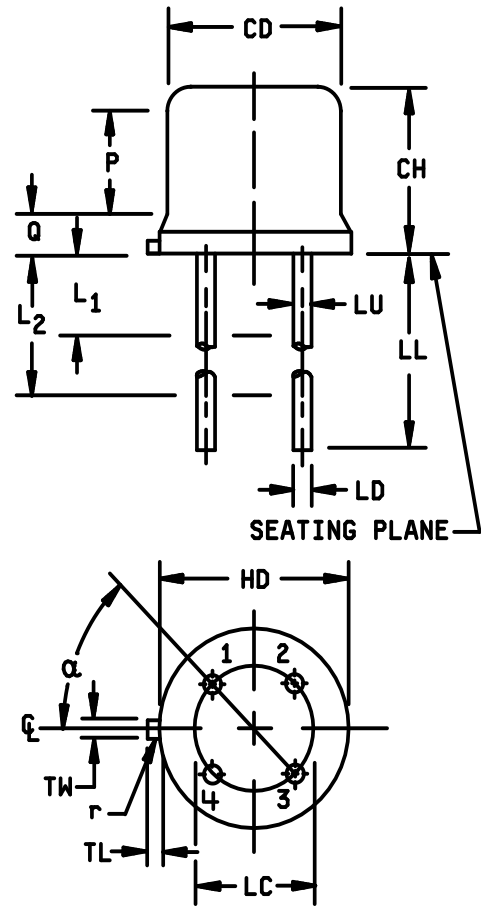

NOTES:

1. Dimension are in inches.
2. Millimeters are given for general information only.
3. Beyond r (radius) maximum, TH shall be held for a minimum length of .011 (0.28 mm).
4. Dimension TL measured from maximum HD.
5. Body contour optional within zone defined by HD, CD, and Q.
6. Leads at gauge plane .054 +.001 -.000 inch (1.37 +0.03 -0.00 mm) below seating plane shall be within .007 inch (0.18mm) radius of true position (TP) at maximum material condition (MMC) relative to tab at MMC. The device may be measured by direct methods or by the gauge and gauging procedure shown in figure 2.
7. Dimension LU applies between L<sub>1</sub> and L<sub>2</sub>. Dimension LD applies between L<sub>2</sub> and LL minimum. Diameter is uncontrolled in L<sub>1</sub> and beyond LL minimum.
8. All four leads.
9. Dimension r (radius) applies to both inside corners of tab.
10. In accordance with ASME Y14.5M, diameters are equivalent to φx symbology.
11. Lead 1 = emitter, lead 2 = base, lead 3 = collector, lead 4 = case (electrically connected).

FIGURE 1. Physical dimensions for 2N2857, (TO-72).

MIL-PRF-19500/343K

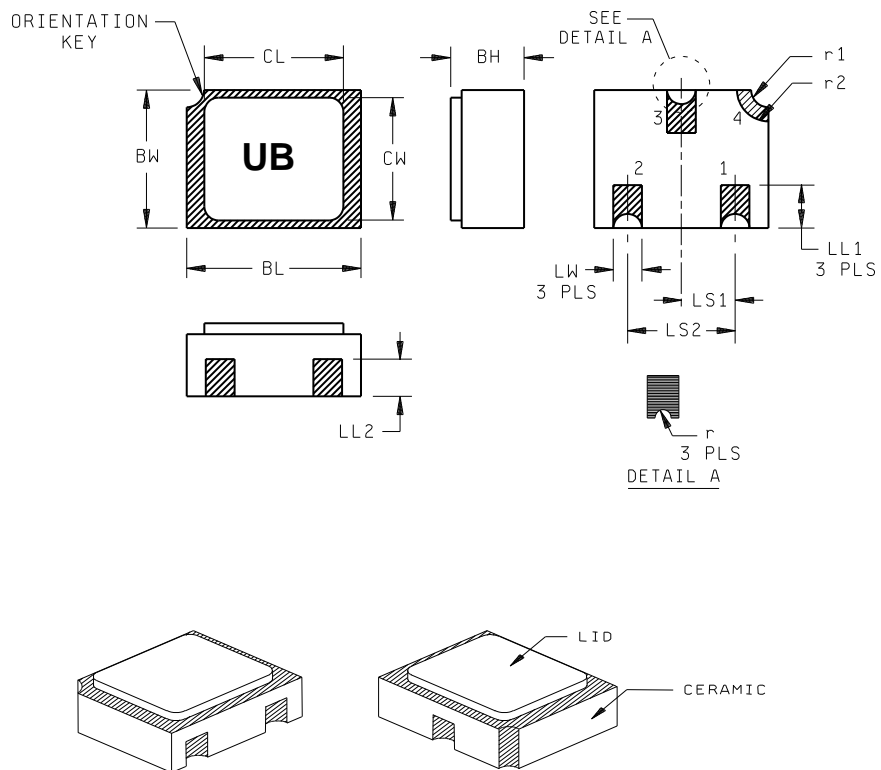

Symbol	Dimensions				Note	Symbol	Dimensions				Note
	Inches		Millimeters				Inches		Millimeters		
	Min	Max	Min	Max			Min	Max	Min	Max	
BH	.046	.056	1.17	1.42		LS1	.035	.040	0.89	1.02	
BL	.115	.128	2.92	3.25		LS2	.071	.079	1.80	2.01	
BW	.085	.108	2.16	2.74		LW	.016	.024	0.41	0.61	
CL		.128		3.25		r		.008		0.20	
CW		.108		2.74		r1		.012		0.31	
LL1	.022	.038	0.56	0.96		r2		.022		0.56	
LL2	.017	.035	0.43	0.89							

NOTES:

1. Dimensions are in inches.
2. Millimeters are given for general information only.
3. Hatched areas on package denote metallized areas.
4. Lid material: Kovar.
5. Pad 1 = base, Pad 2 = emitter, Pad 3 = collector, Pad 4 = shielding connected to the lid.
6. In accordance with ASME Y14.5M, diameters are equivalent to  $\phi x$  symbology.

FIGURE 2. Physical dimensions, surface mount (UB version).

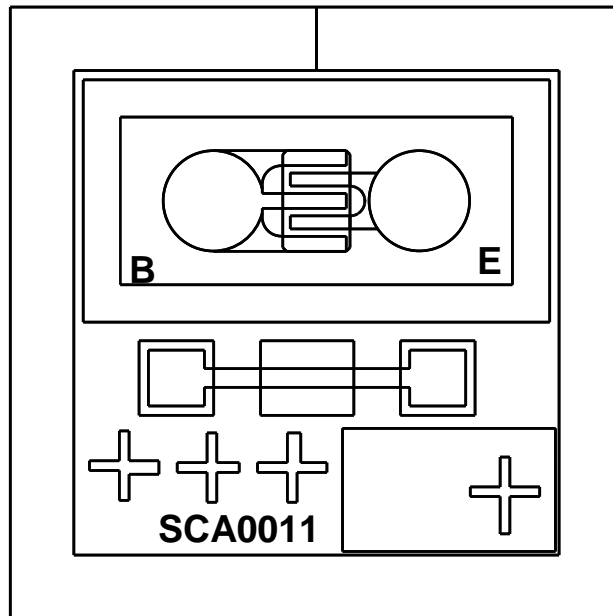

Die size ----- .016 x .016 inch (0.41 x 0.41 mm).  
Die thickness --- .008 ± .0016 inch (0.203 ± 0.041 mm).  
Base pad ----- .0023 x .0023 inch (0.058 x 0.058 mm).  
Emitter pad ---- .0023 x .0023 inch (0.058 x 0.058 mm).  
Back metal: ---- Gold, 6,500 ± 1,950 Å.  
Top metal ----- Aluminum, 17,500 ± 2,500 Å.  
Back side ----- Collector.  
Glassivation ---- SiO<sub>2</sub>, 7,500 ± 1,500 Å.

FIGURE 3. JANHC and JANKC (A-version) die dimensions.

MIL-PRF-19500/343K

3.4.1 Lead finish. Lead finish shall be solderable in accordance with MIL-PRF-19500, MIL-STD-750, and herein. Where a choice of lead finish is desired, it shall be specified in the acquisition document (see 6.2).

3.5 Radiation hardness assurance (RHA). Radiation hardness assurance requirements, PIN designators, and test levels shall be as defined in MIL-PRF-19500.

3.6 Electrical performance characteristics. Unless otherwise specified herein, the electrical performance characteristics are as specified in 1.3, 1.4, and table I.

3.7 Electrical test requirements. The electrical test requirements shall be as specified in table I.

3.8 Marking. Marking shall be in accordance with MIL-PRF-19500. At the option of the manufacturer, marking on the UB package may be omitted from the body, but shall be retained on the initial container.

3.9 Workmanship. Semiconductor devices shall be processed in such a manner as to be uniform in quality and shall be free from other defects that will affect life, serviceability, or appearance.

4. VERIFICATION

4.1 Classification of inspections. The inspection requirements specified herein are classified as follows:

- a. Qualification inspection (see 4.2).
- b. Screening (see 4.3).
- c. Conformance inspection (see 4.4 and tables I, II, III, and IV).

4.2 Qualification inspection. Qualification inspection shall be in accordance with MIL-PRF-19500 and as specified herein.

4.2.1. JANHC and JANKC qualification. JANHC and JANKC qualification inspection shall be in accordance with MIL-PRF-19500.

4.2.2 Group E qualification. Group E inspection shall be performed for qualification or re-qualification only. In case qualification was awarded to a prior revision of the specification sheet that did not request the performance of table IV tests, the tests specified in table IV herein that were not performed in the prior revision shall be performed on the first inspection lot of this revision to maintain qualification.

MIL-PRF-19500/343K

\* 4.3 Screening (JANS, JANTX, and JANTXV levels only). Screening shall be in accordance with table E-IV of MIL-PRF-19500 and as specified herein. The following measurements shall be made in accordance with [table I](#) herein. Devices that exceed the limits of [table I](#) herein shall not be acceptable.

Screen (see table E-IV of MIL-PRF-19500)	Measurement	
	JANS level	JANTX and JANTXV levels
(1) 3c	Thermal impedance, method 3131 of MIL-STD-750 (see <a href="#">4.3.3</a> ).	Thermal impedance, method 3131 of MIL-STD-750 (see <a href="#">4.3.3</a> ).
9	$I_{CES}$ , $h_{FE1}$ .	Not applicable.
10	48 hours minimum.	48 hours minimum.
11	$I_{CES}$ , $h_{FE1}$ ; $\Delta I_{CES}$ = 100 percent of initial value or 5 nA, whichever is greater; $\Delta h_{FE1}$ = 15 percent.	$I_{CES}$ , $h_{FE1}$ .
12	See <a href="#">4.3.1</a> .	See <a href="#">4.3.1</a> .
13	Subgroups 2 and 3 of <a href="#">table I</a> herein; $\Delta I_{CES}$ = 100 percent of initial value or 5 nA dc, whichever is greater; $\Delta h_{FE1}$ = 15 percent .	Subgroup 2 of <a href="#">table I</a> herein; $\Delta I_{CES}$ = 100 percent of initial value or 5 nA dc, whichever is greater; $\Delta h_{FE1}$ = 15 percent.

\* (1) Shall be performed anytime after temperature cycling, screen 3a; TX and TXV do not need to be repeated in screening requirements.

\* 4.3.1 Power burn-in conditions. Power burn-in conditions are as follows:  $V_{CB}$  = 15 V dc;  $P_T$  = 200 mW at,  $T_A$  = room ambient as defined in the general requirements of [4.5](#) of MIL-STD-750. NOTE: No heat sink or forced air cooling on the devices shall be permitted.

4.3.2 Screening (JANHNC and JANKC). Screening of JANHC and JANKC die shall be in accordance with MIL-PRF-19500, "Discrete Semiconductor Die/Chip Lot Acceptance". Burn-in duration for the JANKC level follows JANS requirements; the JANHC follows JANTX requirements.

\* 4.3.3 Thermal impedance. The thermal impedance measurements shall be performed in accordance with method 3131 of MIL-STD-750 using the guidelines in that method for determining  $I_M$ ,  $I_H$ ,  $t_H$ ,  $t_{MD}$  (and  $V_C$  where appropriate). The thermal impedance limit shall comply with the thermal impedance graph on figures 4, 5, and 6 (less than or equal to the curve value at the same  $t_H$  time) and shall be less than the process determined statistical maximum limit as outlined in method 3131 of MIL-STD-750. See [table IV](#), subgroup 4 herein.

4.4 Conformance inspection. Conformance inspection shall be in accordance with MIL-PRF-19500, and as specified herein. If alternate screening is being performed in accordance with E.5.3.1d of MIL-PRF-19500, a sample of screened devices shall be submitted to and pass the requirements of group A1 and A2 inspection only (table E-VIb, group B, subgroup 1 is not required to be performed again if group B has already been satisfied in accordance with [4.4.2](#)).

4.4.1 Group A inspection. Group A inspection shall be conducted in accordance with MIL-PRF-19500, and [table I](#) herein.

4.4.2 Group B inspection. Group B inspection shall be conducted in accordance with the tests and conditions specified for subgroup testing in table E-VIa (JANS) of MIL-PRF-19500 and 4.4.2.1 herein. See 4.4.2.2 herein for JAN, JANTX, and JANTXV group B testing. Electrical measurements (end-points) shall be in accordance with table I, subgroup 2 herein. Delta measurements shall be in accordance with table III herein.

\* 4.4.2.1 Group B inspection, table E-VIa (JANS) of MIL-PRF-19500.

<u>Subgroup</u>	<u>Method</u>	<u>Conditions</u>
* B4	1037	$V_{CB} = 5 - 15$ V dc, 2,000 cycles, $t_{ON} = t_{OFF} = 3$ minutes, $P_{D(ON)} = P_D$ max rated in accordance with 1.3; $P_{D(OFF)} = 0$ .
B5	1027	$V_{CB} = 10$ V dc; 340 hours maximum rated power shall be applied and ambient temperature adjusted to achieve $T_J = +150^\circ\text{C}$ minimum. $n = 45$ , $c = 0$ .

\* 4.4.2.2 Group B inspection, table E-VIb (JAN, JANTX, and JANTXV). Separate samples may be used for each step. In the event of a group B failure, the manufacturer may pull a new sample at double size from either the failed assembly lot or from another assembly lot from the same wafer lot. If the new "assembly lot" option is exercised, the failed assembly lot shall be scrapped.

<u>Step</u>	<u>Method</u>	<u>Conditions</u>
* 1	1026	1,000 hours at $V_{CB} = 10$ V dc; power shall be applied and ambient temperature adjusted to achieve $T_J = +150^\circ\text{C}$ minimum and a minimum of $PD = 100$ percent of maximum rated PT as defined in 1.3 $n = 45$ , $c = 0$ . The sample size may be increased and the test time decreased as long as the devices are stressed for a total of 45,000 device hours minimum, and the actual time of test is at least 340 hours.
2	1048	Blocking life: $T_A = +150^\circ\text{C}$ , $V_{CB} = 80$ percent of rated voltage, 48 hours minimum. $n = 45$ devices, $c = 0$ .
3	1032	High temperature life (non-operating), $t = 340$ hours; $T_A = +200^\circ\text{C}$ . $n = 22$ , $c = 0$ .

4.4.2.3 Group B sample selection. Samples selected from group B inspection shall meet all of the following requirements:

- For JAN, JANTX, and JANTXV samples shall be selected randomly from a minimum of three wafers (or from each wafer in the lot) from each wafer lot. For JANS, samples shall be selected from each inspection lot. See MIL-PRF-19500.
- Shall be chosen from an inspection lot that has been submitted to and passed group A conformance inspection. When the final lead finish is solder or any plating prone to oxidation at high temperature, the samples for life test (subgroups B4 and B5 for JANS, and group B for JAN, JANTX, and JANTXV) may be pulled prior to the application of final lead finish.

\* 4.4.3 Group C inspection. Group C inspection shall be conducted in accordance with the tests and conditions specified for subgroup testing in table E-VII of MIL-PRF-19500, and in 4.4.3.1 herein (JANS). See 4.4.3.2 herein for JAN, JANTX, and JANTXV group C testing. Electrical measurements (end-points) shall be in accordance with table I, subgroup 2 herein. Delta measurements shall be in accordance with table III herein.



\* 4.4.3.1 Group C inspection, JANS, table E-VII of MIL-PRF-19500.

<u>Subgroup</u>	<u>Method</u>	<u>Condition</u>
C2	2036	Test condition E; not applicable for UB devices.
C5	3131	$R_{\theta JA}$ and $R_{\theta JC}$ only, as applicable (see 1.3).
* C6	1026	1,000 hours at VCB = 10 V dc; power shall be applied and ambient temperature adjusted to achieve $T_J = +150^\circ\text{C}$ minimum and a minimum of PD = 100 percent of maximum rated PT as defined in 1.3 $n = 45$ , $c = 0$ . The sample size may be increased and the test time decreased as long as the devices are stressed for a total of 45,000 device hours minimum, and the actual time of test is at least 340 hours.

4.4.3.2 Group C inspection, JAN, JANTX, and JANTXV, table E-VII of MIL-PRF-19500.

<u>Subgroup</u>	<u>Method</u>	<u>Condition</u>
C2	2036	Test condition E; not applicable for UB devices.
C5	3131	$R_{\theta JA}$ and $R_{\theta JC}$ only, as applicable (see 1.3).
C6		Not applicable.

4.4.3.3 Group C sample selection. Samples for subgroups in group C shall be chosen at random from any inspection lot containing the intended package type and lead finish procured to the same specification which is submitted to and passes group A tests for conformance inspection. When the final lead finish is solder or any plating prone to oxidation at high temperature, the samples for C6 life test may be pulled prior to the application of final lead finish. Testing of a subgroup using a single device type enclosed in the intended package type shall be considered as complying with the requirements for that subgroup.

4.4.4 Group D inspection. Conformance inspection for hardness assured JANS, JANJ, and JANTXV types shall include the group D tests specified in [table II](#) herein. These tests shall be performed as required in accordance with MIL-PRF-19500 and method 1019 of MIL-STD-750, for total ionizing dose or method 1017 of MIL-STD-750 for neutron fluence as applicable (see [6.2](#) herein), except group D, subgroup 2 may be performed separate from other subgroups.

\* 4.4.5 Group E inspection. Group E inspection shall be conducted in accordance with the conditions specified for subgroup testing in table E-IX of MIL-PRF-19500 and as specified in [table IV](#) herein. Electrical measurements (end-points) shall be in accordance with [table I](#), subgroup 2 herein.

4.5 Method of inspection. Methods of inspection shall be as specified in the appropriate tables and as follows.

4.5.1 Pulse measurements. Conditions for pulse measurement shall be as specified in section 4 of MIL-STD-750.

\* 4.5.2 Noise figure. The noise figure shall be measured using commercially available test equipment and its associated standard test procedures (see figures 7 and 8).

MIL-PRF-19500/343K

\* TABLE I. Group A inspection.

Inspection <u>1/</u>	MIL-STD-750		Symbol	Limits		Unit
	Method	Conditions		Min	Max	
<u>Subgroup 1 2/</u>						
* Visual and mechanical examination	2071					
Solderability <u>3/ 4/</u>	2026	n = 15 leads, c = 0				
Resistance to solvents <u>3/ 4/ 5/</u>	1022	n = 15 devices, c = 0				
Temp cycling <u>3/ 4/</u>	1051	Test condition C, 25 cycles. n = 22 devices, c = 0				
Hermetic seal <u>4/ 6/</u> Fine leak Gross leak	1071	n = 22 devices, c = 0				
Electrical measurements <u>4/</u>		<a href="#">Table I</a> , subgroup 2				
Bond strength <u>3/ 4/</u>	2037	Precondition T <sub>A</sub> = +250°C at t = 24 hrs or T <sub>A</sub> = +300°C at t = 2 hrs n = 11 wires, c = 0				
De-cap internal visual	2075	n = 4, c = 0				
<u>Subgroup 2</u>						
Thermal impedance	3131	See <a href="#">4.3.3</a>	Z <sub>θJX</sub>			mV
Breakdown voltage, collector to emitter	3011	Bias condition D; I <sub>C</sub> = 3 mA dc	V <sub>(BR)CEO</sub>	15		V dc
Collector to base cutoff current	3036	Bias condition D; V <sub>CB</sub> = 15 V dc	I <sub>CBO1</sub>		10	nA dc
Collector to base cutoff current	3036	Bias condition D; V <sub>CB</sub> = 30 V dc	I <sub>CBO3</sub>		1	μA dc
Emitter to base cutoff current	3061	Bias condition D; V <sub>EB</sub> = 3 V dc	I <sub>EBO1</sub>		10	μA dc
Forward-current transfer ratio	3076	V <sub>CE</sub> = 1 V dc; I <sub>C</sub> = 3 mA dc	h <sub>FE1</sub>	30	150	
Collector-emitter saturation voltage	3071	I <sub>C</sub> = 10 mA dc; I <sub>B</sub> = 1 mA dc;	V <sub>CE(sat)</sub>		0.4	V dc

See footnotes at end of table.

\* TABLE I. Group A inspection - Continued.

Inspection 1/	MIL-STD-750		Symbol	Limits		Unit
	Method	Conditions		Min	Max	
<u>Subgroup 2</u> - Continued.						
Base-emitter saturation voltage	3066	Test condition A; $I_C = 10$ mA dc; $I_B = 1$ mA dc	$V_{BE(sat)}$		1.0	V dc
Collector to emitter cutoff current	3041	Bias condition C; $V_{CE} = 16$ V dc	$I_{CES}$		100	nA dc
<u>Subgroup 3</u>						
High temperature operation		$T_A = +150^\circ\text{C}$				
Collector to base cutoff current		Bias condition D; $V_{CB} = 15$ V dc	$I_{CBO2}$		1.0	$\mu\text{A}$ dc
Low temperature operation		$T_A = -55^\circ\text{C}$				
Forward-current transfer ratio	3076	$V_{CE} = 1$ V dc; $I_C = 3$ mA dc	$h_{FE2}$	10		
<u>Subgroup 4</u>						
* Noise figure	3246	$V_{CE} = 6$ V dc; $I_C = 1.5$ mA dc; $f = 450$ MHz; $R_g = 50 \Omega$ (case lead grounded) (see 4.5.2 and figure 7)	F		4.5	dB
Magnitude of common-emitter small-signal short-circuit forward-current transfer ratio	3306	$V_{CE} = 6$ V dc; $I_C = 5$ mA dc; $f = 100$ MHz (case lead grounded)	$ h_{fe} $	10	21	
Small-signal short-circuit forward current transfer ratio	3206	$V_{CE} = 6$ V dc; $I_C = 2$ mA dc; (case lead floating)	$h_{fe}$	50	220	
Collector to base -feedback capacitance		$V_{CB} = 10$ V dc; $I_E = 0$ mA dc; $100 \text{ kHz} \leq f \leq 1 \text{ MHz}$ (see 4.5.1)	$C_{cb}$		1.0	pF
Small-signal power gain	3256	$V_{CE} = 6$ V dc; $I_E = 1.5$ mA dc; $f = 450$ MHz	$G_{pe}$	12.5	21	dB

See footnotes at end of table.

MIL-PRF-19500/343K

\* TABLE I. Group A inspection - Continued.

Inspection 1/	MIL-STD-750		Symbol	Limits		Unit
	Method	Conditions		Min	Max	
<u>Subgroup 4 - Continued.</u> Collector-base time constant <u>Subgroups 5, 6, and 7</u> Not applicable		$V_{CB} = 6 \text{ V dc}; I_E = 2 \text{ mA dc};$ $f = 31.9 \text{ MHz}$ (see <a href="#">figure 8</a> )	$r_b' C_c$	4	15	ps

1/ For sampling plan (unless otherwise specified), see MIL-PRF-19500.

2/ For resubmission of failed subgroup A1, double the sample size of the failed test or sequence of tests. A failure in group A, subgroup 1 shall not require retest of the entire subgroup. Only the failed test shall be rerun upon submission.

3/ Separate samples may be used.

4/ Not required for JANS devices.

5/ Not required for laser marked devices.

6/ This hermetic seal test is an end-point to temp-cycling in addition to electrical measurements.

## MIL-PRF-19500/343K

TABLE II. Group D inspection.

Inspection <u>1/ 2/ 3/</u>	MIL-STD-750		Symbol	Limit		Unit
	Method	Conditions		Min	Max	
<u>Subgroup 1 4/</u>						
Neutron irradiation	1017	Neutron exposure $V_{CES} = 0$ V				
Breakdown voltage, collector to emitter	3011	Bias condition D; $I_C = 3$ mA dc	$V_{(BR)CEO}$	15		V dc
Collector to base cutoff current	3036	Bias condition D; $V_{CB} = 15$ V dc	$I_{CBO1}$		20	nA dc
Collector to base cutoff current	3036	Bias condition D; $V_{CB} = 30$ V dc	$I_{CBO3}$		2	$\mu$ A dc
Emitter to base cutoff current	3061	Bias condition D; $V_{EB} = 3$ V dc	$I_{EBO1}$		20	$\mu$ A dc
Forward-current transfer ratio	3076	$V_{CE} = 1$ V dc; $I_C = 3$ mA dc	$[h_{FE1}]$	[15]	150	
Collector-emitter saturation voltage	3071	$I_C = 10$ mA dc; $I_B = 1$ mA dc;	$V_{CE(sat)}$		0.46	V dc
Base-emitter saturation voltage	3066	Test condition A; $I_C = 10$ mA dc; $I_B = 1$ mA dc	$V_{BE(sat)}$		1.15	V dc
Collector to emitter cutoff current	3041	Bias condition C; $V_{CE} = 16$ V dc	$I_{CES}$		200	nA dc
<u>Subgroup 2</u>						
Total dose irradiation	1019	Gamma exposure $V_{CES} = 12$ V Condition A				
Breakdown voltage, collector to emitter	3011	Bias condition D; $I_C = 3$ mA dc	$V_{(BR)CEO}$	15		V dc
Collector to base cutoff current	3036	Bias condition D; $V_{CB} = 15$ V dc	$I_{CBO1}$		20	nA dc
Collector to base cutoff current	3036	Bias condition D; $V_{CB} = 30$ V dc	$I_{CBO3}$		2	$\mu$ A dc
Emitter to base cutoff current	3061	Bias condition D; $V_{EB} = 3$ V dc	$I_{EBO1}$		20	$\mu$ A dc
Forward-current transfer ratio	3076	$V_{CE} = 1$ V dc; $I_C = 3$ mA dc	$[h_{FE1}]$	[15]	150	

See footnotes at end of table.

TABLE II. Group D inspection - Continued.

Inspection <u>1/</u> <u>2/</u> <u>3/</u>	MIL-STD-750		Symbol	Limit		Unit
	Method	Conditions		Min	Max	
<u>Subgroup 2</u> - Continued.						
Collector-emitter saturation voltage	3071	$I_C = 10 \text{ mA dc};$ $I_B = 1 \text{ mA dc};$	$V_{CE(sat)}$		0.46	V dc
Base-emitter saturation voltage	3066	Test condition A; $I_C = 10 \text{ mA dc};$ $I_B = 1 \text{ mA dc}$	$V_{BE(sat)}$		1.15	V dc
Collector to emitter cutoff current	3041	Bias condition C; $V_{CE} = 16 \text{ V dc}$	$I_{CES}$		200	nA dc

1/ Tests to be performed on all devices receiving radiation exposure.

2/ For sampling plan, see MIL-PRF-19500.

3/ Electrical characteristics apply to the corresponding AL, UA, UB, and UBC suffix versions unless otherwise noted.

4/ See 6.2.f herein.

5/ See method 1019 of MIL-STD-750 for how to determine  $[h_{FE}]$  by first calculating the delta ( $1/h_{FE}$ ) from the pre- and post-radiation  $h_{FE}$ . The  $[h_{FE}]$  is not the same as  $h_{FE}$  and cannot be measured directly. The  $[h_{FE}]$  value can never exceed the pre-radiation minimum  $h_{FE}$  that it is based upon.

TABLE III. Groups B, C, and E delta measurements. 1/ 2/ 3/ 4/

Step	Inspection	MIL-STD-750		Symbol	Limit		Unit
		Method	Conditions		Min	Max	
2.	Forward current transfer ratio	3076	$V_{CE} = 1.0 \text{ V dc};$ $I_C = 3 \text{ mA dc}$	$\Delta h_{FE1}$	$\pm 25$ percent change from initial value.		
3.	Collector to emitter voltage (saturated)	3071	$I_C = 10 \text{ mA dc};$ $I_B = 1.0 \text{ mA dc}$	$\Delta V_{CE(sat)}$ <u>5/</u>	$\pm 50 \text{ mV dc}$ change from initial value.		

1/ The delta measurements for table E-VIa (JANS) of MIL-PRF-19500 are as follows:

- a. Subgroup 3, see [table II](#) herein, step 1.
- b. Subgroups 4 and 5, see [table II](#) herein, step 3.

2/ The delta measurements for group B, [4.4.2.2](#) herein (JAN, JANTX, and JANTXV) are as follows:

Steps 1, 2, and 3 of [4.4.2.2](#), see [table II](#) herein, all steps.

3/ The delta measurements for table E-VII (JANS) of MIL-PRF-19500 are as follows:

- a. Subgroup 2 and 3, see [table II](#) herein, step 1.
- b. Subgroup 6, see [table II](#) herein, all steps.

4/ The delta measurements for table E-IX of MIL-PRF-19500 are: Subgroups 1 and 2, see [table II](#) herein, all steps.

5/ Devices which exceed the group A limits for this test shall not be acceptable.

MIL-PRF-19500/343K

\* TABLE IV. Group E inspection (all quality levels) - for qualification or requalification only.

Inspection	MIL-STD-750		Qualification
	Method	Conditions	
<u>Subgroup 1</u>			45 devices c = 0
Temperature cycling (air to air)	1051	Test condition C, 500 cycles.	
Hermetic seal Fine leak Gross leak	1071	Test conditions G or H. Test conditions C or D.	
Electrical measurements		See <a href="#">table I</a> , subgroup 2 and <a href="#">table III</a> herein.	
<u>Subgroup 2</u>			45 devices c = 0
Intermittent life	1037	Intermittent operation life: $V_{CB} = 10$ V dc; 6,000 cycles; $t_{ON} = t_{OFF} = 3$ minutes, $P_{D(ON)} = P_D$ max rated in accordance with <a href="#">1.3</a> ; $P_{D(OFF)} = 0$ .	
Electrical measurements		See <a href="#">table I</a> , subgroup 2 and <a href="#">table III</a> herein.	
<u>Subgroup 4</u>			
Thermal impedance curves		See table E-IX of MIL-PRF-19500, group E, subgroup 4. $R_{\theta JSP}$ for UB devices only, Sample size = 15, c = 0, can be calculated but shall be measured once in the same package with a similar die size to confirm calculations (may apply to multiple specification sheets).	
<u>Subgroup 5</u>			
Not applicable			
<u>Subgroup 6</u>			11 devices
ESD	1020		
<u>Subgroup 8</u>			45 devices c = 0
Reverse stability	1033	Condition B.	

\*



### Maximum Thermal Impedance

2N2857UB 16x16 Chip in UB LCC3 Package, Heavy PCB, Tsp=25C,  $\theta_{j\text{sp}}=210\text{C/W}$

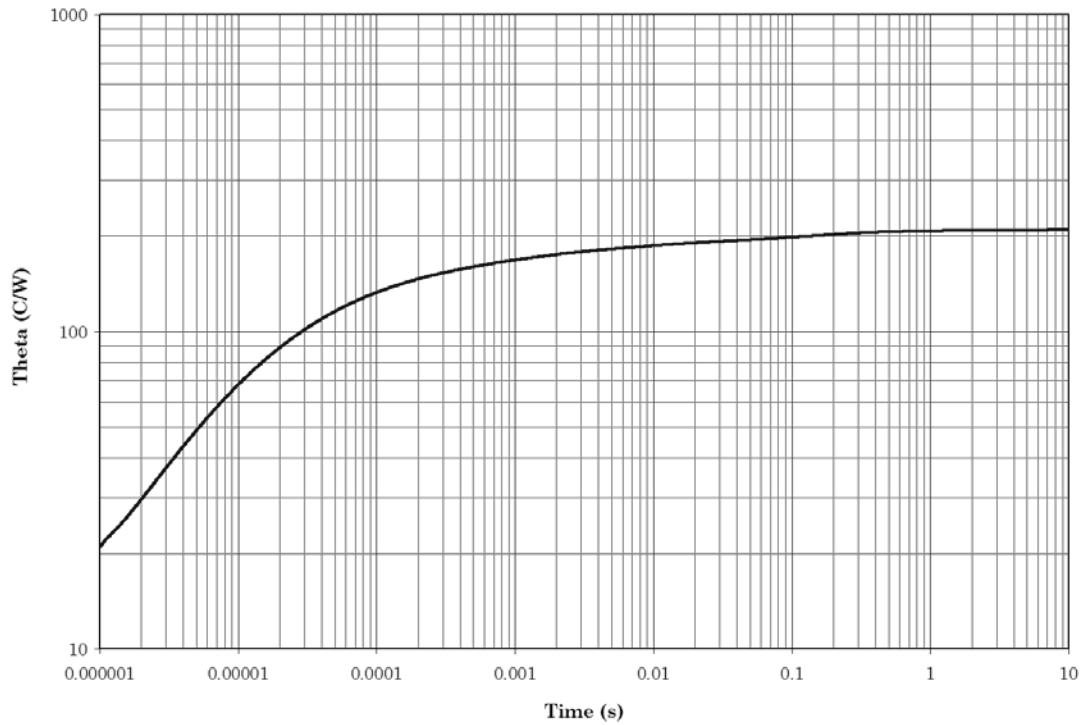
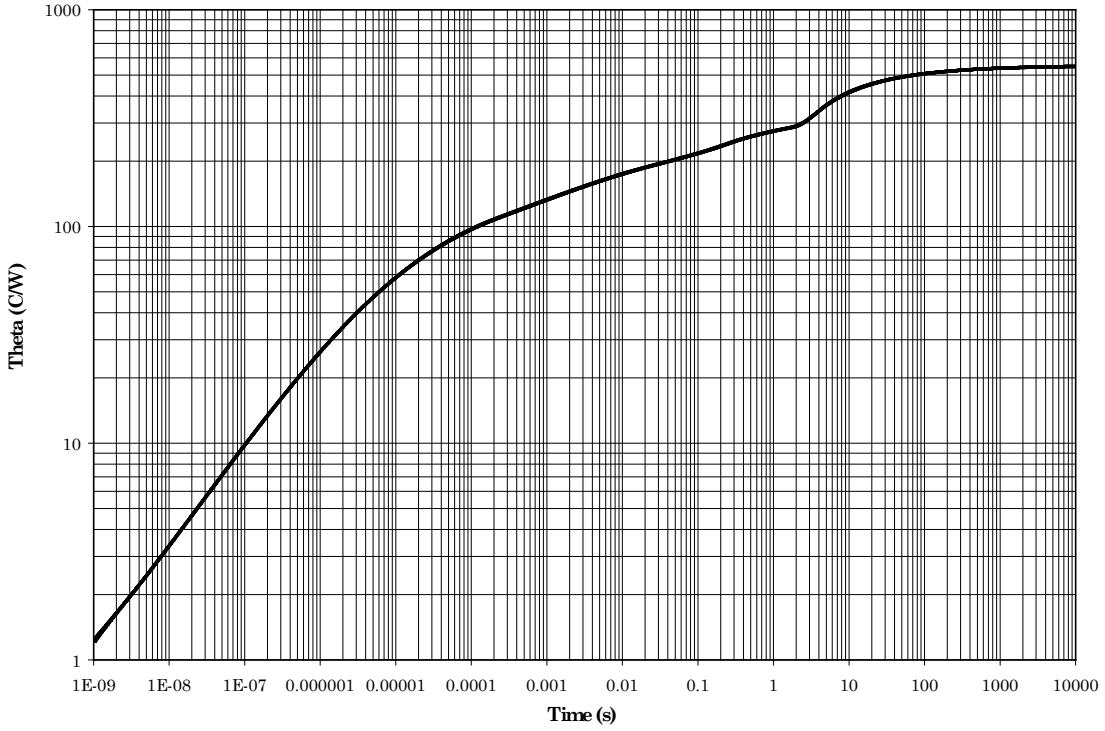

FIGURE 4. Thermal impedance graph ( $R_{\theta\text{JSP}}$ ) for 2N2857UB.

### Maximum Thermal Impedance

2N2857 TO-72 Package, Ta=25C, 16x16 SEA Chip, 2N2857



\* FIGURE 5. Thermal impedance graph TO-72 ( $R_{\theta JA}$ ) for 2N2857.

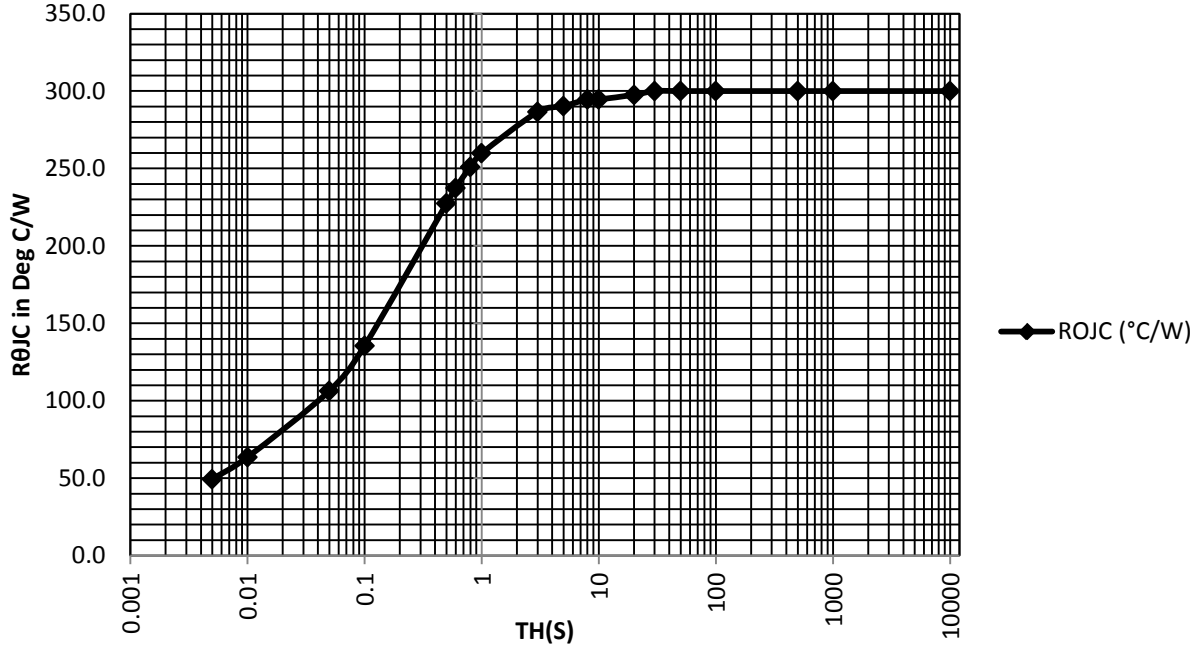

\* FIGURE 6. Thermal impedance graph TO-72 ( $R_{\theta JC}$ ) for 2N2857.

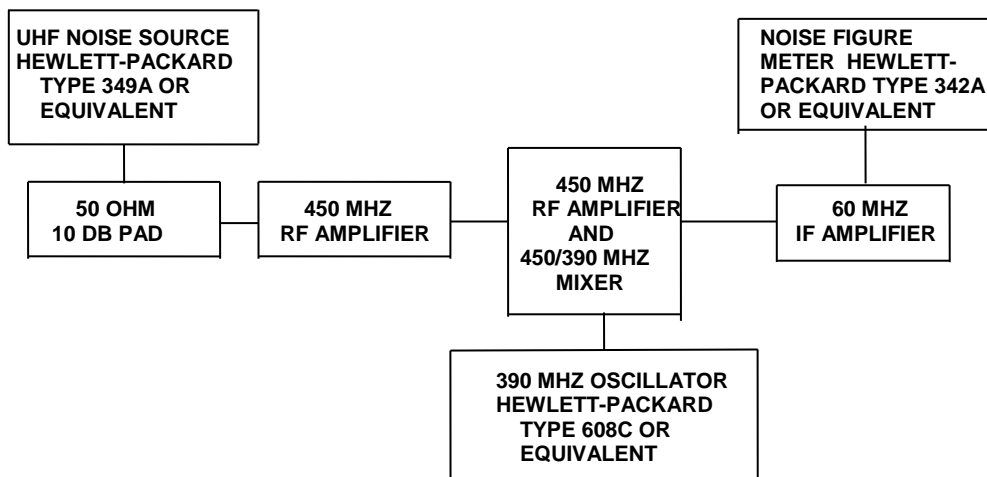

FIGURE 7. Block diagram for noise figure test.

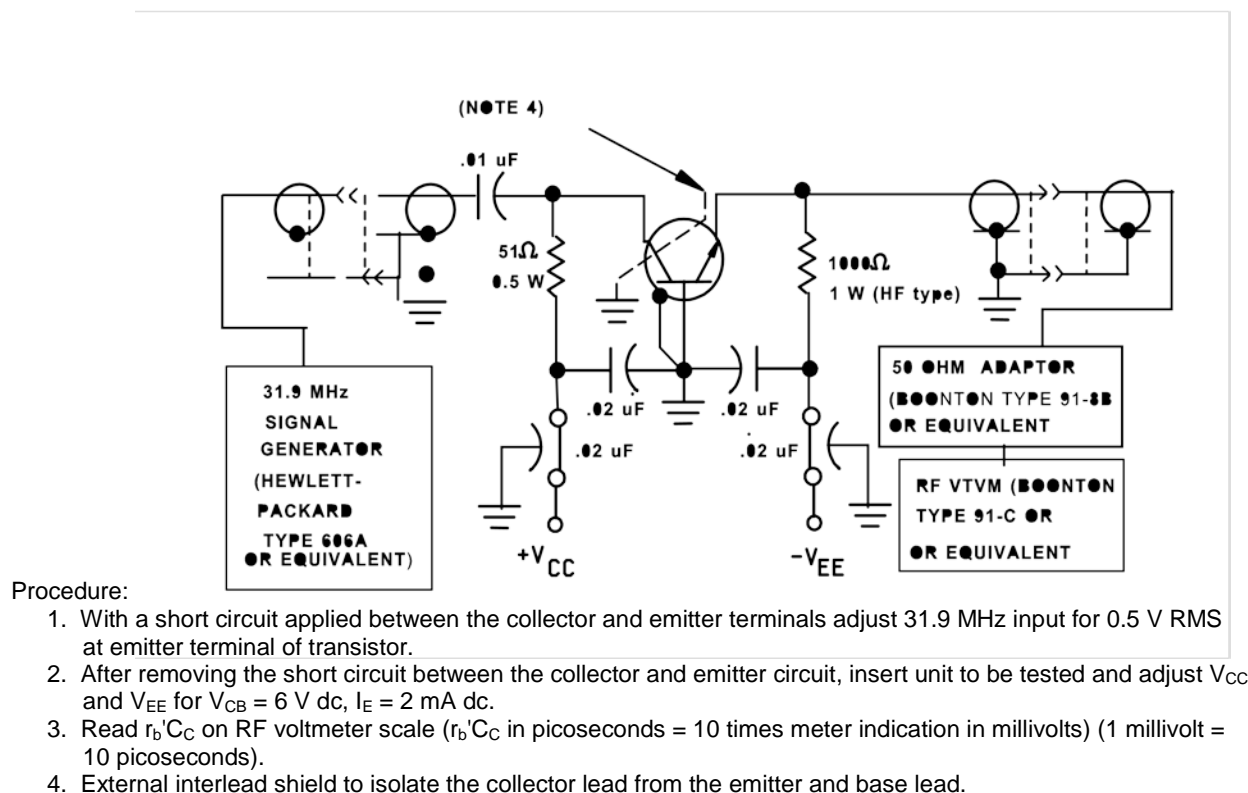

FIGURE 8. Collector-base time constant test circuit (an equivalent circuit may be used).

## 5. PACKAGING

5.1 Packaging. For acquisition purposes, the packaging requirements shall be as specified in the contract or order (see 6.2). When packaging of materiel is to be performed by DoD or in-house contractor personnel, these personnel need to contact the responsible packaging activity to ascertain packaging requirements. Packaging requirements are maintained by the Inventory Control Point's packaging activities within the Military Service or Defense Agency, or within the Military Service's system commands. Packaging data retrieval is available from the managing Military Department's or Defense Agency's automated packaging files, CD-ROM products, or by contacting the responsible packaging activity.

## 6. NOTES

(This section contains information of a general or explanatory nature that may be helpful, but is not mandatory. The notes specified in MIL-PRF-19500 are applicable to this specification.)

6.1 Intended use. Semiconductors conforming to this specification are intended for original equipment design applications and logistic support of existing equipment.

6.2 Acquisition requirements. Acquisition documents should specify the following:

- a. Title, number, and date of this specification.
- b. Packaging requirements (see 5.1).
- c. Lead finish (see 3.4.1).
- d. Product assurance level and type designator.
- e. For die acquisition, the JANHC or JANKC letter version shall be specified (see figure 3).
- f. For acquisition of RHA designated devices, table II, subgroup 1 testing of group D herein is optional. If subgroup 1 is desired, it should be specified in the contract.

\* 6.3 Qualification. With respect to products requiring qualification, awards will be made only for products which are, at the time of award of contract, qualified for inclusion in Qualified Manufacturers List (QML 19500) whether or not such products have actually been so listed by that date. The attention of the contractors is called to these requirements, and manufacturers are urged to arrange to have the products that they propose to offer to the Federal Government tested for qualification in order that they may be eligible to be awarded contracts or orders for the products covered by this specification. Information pertaining to qualification of products may be obtained from DLA Land and Maritime, ATTN: VQE, P.O. Box 3990, Columbus, OH 43218-3990 or e-mail [vqe.chief@dla.mil](mailto:vqe.chief@dla.mil). An online listing of products qualified to this specification may be found in the Qualified Products Database (QPD) at <https://assist.daps.dla.mil>.

6.4 Suppliers of JANHC and JANKC die. The qualified JANHC and JANKC suppliers with the applicable letter version (example JANHCA2N2857) will be identified on the QML.

Die ordering information	
PIN	Manufacturer
	2N2857

6.5 Changes from previous issue. The margins of this specification are marked with asterisks to indicate where changes from the previous issue were made. This was done as a convenience only and the Government assumes no liability whatsoever for any inaccuracies in these notations. Bidders and contractors are cautioned to evaluate the requirements of this document based on the entire content irrespective of the marginal notations and relationship to the last previous issue.

Custodians:

Army - CR  
 Navy - EC  
 Air Force - 85  
 NASA - NA  
 DLA - CC

Preparing activity:  
 DLA - CC

(Project 5961-2011-025)

Review activities:

Army - MI, SM  
 Navy - AS, MC  
 Air Force - 19, 71, 99

NOTE: The activities listed above were interested in this document as of the date of this document. Since organizations and responsibilities can change, you should verify the currency of the information above using the ASSIST Online database at <https://assist.daps.dla.mil>.