

The documentation and process conversion measures necessary to comply with this document shall be completed by 18 January 2012.

INCH-POUND

MIL-PRF-19500/301L  
w/AMENDMENT 1  
18 October 2011  
SUPERSEDING  
MIL-PRF-19500/301L  
18 July 2011

PERFORMANCE SPECIFICATION SHEET

\* SEMICONDUCTOR DEVICE, TRANSISTOR, NPN SILICON, LOW-POWER,  
TYPE 2N918 AND 2N918UB, JAN, JANTX, JANTXV, JANS, JANSM, JANSD, JANSP, JANSL, JANSR, JANSF,  
JANSJ, JANSH, JANHC, JANKC, JANHCB, JANHCM, JANHCD, JANHCP, JANHCL, JANHCR, JANHCF, JANHCG,  
JANHCH, JANKCM, JANKCD, JANKCP, JANKCL, JANKCR, JANKCF, JANKCG, AND JANKCH

This specification is approved for use by all Departments and Agencies of the Department of Defense.

The requirements for acquiring the product described herein shall consist of this specification sheet and MIL-PRF-19500.

1. SCOPE

1.1 Scope. This specification covers the detail requirements for NPN, silicon, ultra-high frequency transistors. Four levels of product assurance are provided for each device type as specified in MIL-PRF-19500 and two levels of product assurance are provided for unencapsulated devices. RHA level designators "M", "D", "P", "L", "R", "F", "G", and "H" are appended to the device prefix to identify devices which have passed RHA requirements.

1.2 Physical dimensions. See figure 1 (TO-72), figure 2 (UB), figure 3 (JANHC and JANKC, A versions), and figure 4 (JANHCB, B version).

1.3 Maximum ratings.  $T_A = +25^\circ\text{C}$ , unless otherwise specified.

Types	$P_T$ (1) $T_A = +25^\circ\text{C}$	$R_{\theta JA}$	$R_{\theta JSP}$	$V_{CBO}$	$V_{CEO}$	$V_{EBO}$	$I_C$	$T_{STG}$ and $T_J$
	<u>mW</u>	<u><math>^\circ\text{C/W}</math></u>	<u><math>^\circ\text{C/W}</math></u>	<u>V dc</u>	<u>V dc</u>	<u>V dc</u>	<u>mA dc</u>	<u><math>^\circ\text{C}</math></u>
2N918	200	(2)		30	15	3.0	50	-65 to +200
2N918UB	200		(2)	30	15	3.0	50	

(1) Derate linearly, 1.14 mW/ $^\circ\text{C}$  above  $T_A = +25^\circ\text{C}$ .

(2) See figures 5 and 6 for the manufacturer estimated  $R_{\theta J}$  curves.

1.4 Primary electrical characteristics at  $T_A = +25^\circ\text{C}$ .

Limit	$ h_{FE} $ $V_{CE} = 10 \text{ V dc}$ $I_C = 4 \text{ mA dc}$ $f = 100 \text{ MHz}$	$r_b' C_C$ $V_{CB} = 10 \text{ V dc}$ $I_E = -4.0 \text{ mA dc}$ $f = 79.8 \text{ MHz}$	$C_{obo2}$ $V_{CB} = 10 \text{ V dc}$ $I_E = 0 \text{ mA dc}$ $100 \text{ kHz} \leq f \leq 1 \text{ MHz}$	NF $V_{CE} = 6 \text{ V dc}$ $I_C = 1 \text{ mA dc}$ $f = 60 \text{ MHz}$ $g_s = 2.5 \text{ mmho}$	$G_{pe}$ $V_{CB} = 12 \text{ V dc}$ $I_C = 6.0 \text{ mA dc}$ $f = 200 \text{ MHz}$
		<u>ps</u>	<u>pF</u>	<u>DB</u>	<u>dB</u>
Minimum	6.0				15
Maximum	18.0	25	1.7	6.0	

Comments, suggestions, or questions on this document should be addressed to DLA Land and Maritime, ATTN: VAC, P.O. Box 3990, Columbus, OH 43218-3990, or emailed to [Semiconductor@dla.mil](mailto:Semiconductor@dla.mil). Since contact information can change, you may want to verify the currency of this address information using the ASSIST Online database at <https://assist.daps.dla.mil>.

MIL-PRF-19500/301L  
w/AMENDMENT 1

1.4 Primary electrical characteristics at  $T_A = +25^\circ\text{C}$ . - Continued.

Limit	$h_{FE1}$ $V_{CE} = 10 \text{ V dc}$ $I_C = 500 \mu\text{A dc}$	$h_{FE2}$ $V_{CE} = 1.0 \text{ V dc}$ $I_C = 3.0 \text{ mA dc}$	$h_{FE3}$ $V_{CB} = 10 \text{ V dc}$ $I_C = 10 \text{ mA dc}$
Minimum	10	20	20
Maximum		200	

2. APPLICABLE DOCUMENTS

2.1 General. The documents listed in this section are specified in sections 3, 4, or 5 of this specification. This section does not include documents cited in other sections of this specification or recommended for additional information or as examples. While every effort has been made to ensure the completeness of this list, document users are cautioned that they must meet all specified requirements of documents cited in sections 3, 4, or 5 of this specification, whether or not they are listed.

2.2 Government documents.

2.2.1 Specifications, standards, and handbooks. The following specifications, standards, and handbooks form a part of this document to the extent specified herein. Unless otherwise specified, the issues of these documents are those cited in the solicitation or contract.

DEPARTMENT OF DEFENSE SPECIFICATIONS

MIL-PRF-19500 - Semiconductor Devices, General Specification for.

DEPARTMENT OF DEFENSE STANDARDS

MIL-STD-750 - Test Methods for Semiconductor Devices.

(Copies of these documents are available online at <https://assist.daps.dla.mil/quicksearch> or <https://assist.daps.dla.mil> or from the Standardization Document Order Desk, 700 Robbins Avenue, Building 4D, Philadelphia, PA 19111-5094.)

2.3 Order of precedence Unless otherwise noted herein or in the contract, in the event of a conflict between the text of this document and the references cited herein, the text of this document takes precedence. Nothing in this document, however, supersedes applicable laws and regulations unless a specific exemption has been obtained.

3. REQUIREMENTS

3.1 General. The individual item requirements shall be as specified in MIL-PRF-19500 and as modified herein.

3.2 Qualification. Devices furnished under this specification shall be products that are manufactured by a manufacturer authorized by the qualifying activity for listing on the applicable qualified manufacturer's list (QML) before contract award (see 4.2 and 6.3).

3.3 Abbreviations, symbols, and definitions. Abbreviations, symbols, and definitions used herein shall be as specified in MIL-PRF-19500 and as follows.

$g_s$ ..... Noise source conductance.  
 $P_o$ ..... Oscillator, power output.  
 $R_{BE}$  External resistance, base to emitter.

MIL-PRF-19500/301L  
w/AMENDMENT 1

Symbol	Dimensions				Notes
	Inches		Millimeters		
	Min	Max	Min	Max	
CD	.178	.195	4.52	4.95	5
CH	.170	.210	4.32	5.33	
HD	.209	.230	5.31	5.84	5
LC	.100 TP		2.54 TP		7,8
LD	.016	.021	.406	.533	7,8
LL	.500	.750	12.70	19.05	7,8
LU	.016	.019	.406	.483	
L <sub>1</sub>		.050		1.27	
L <sub>2</sub>	.250		6.35		
P	.100		2.54		
Q		.040		1.02	5
TL	.028	.048	.71	1.22	
TW	.036	.046	.91	1.17	
r		.007		.18	
α	45° TP				

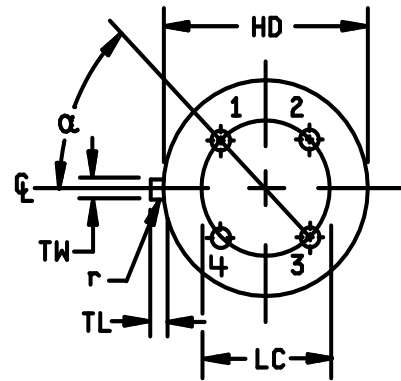
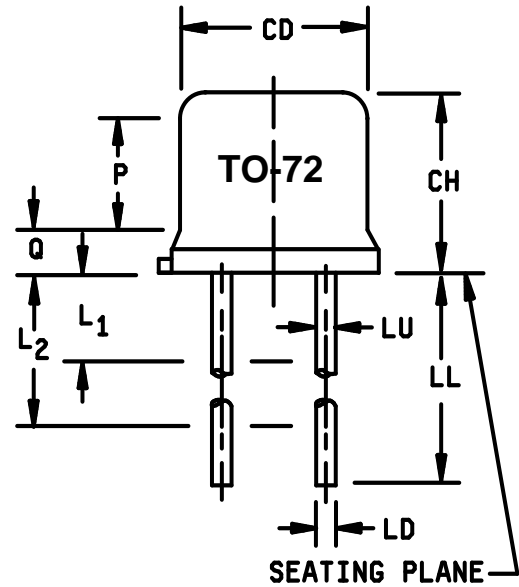

NOTES:

1. Dimension are in inches.
2. Millimeters are given for general information only.
3. Beyond r (radius) maximum, TH shall be held for a minimum length of .011 inch (0.28 mm).
4. Dimension TL measured from maximum HD.
5. Body contour optional within zone defined by HD, CD, and Q.
6. Leads at gauge plane .054 +.001 -.000 inch (1.37 +0.025 -0.00 mm) below seating plane shall be within .007 inch (0.18mm) radius of true position (TP) at maximum material condition (MMC) relative to tab at MMC.
7. Dimension LU applies between L<sub>1</sub> and L<sub>2</sub>. Dimension LD applies between L<sub>2</sub> and LL minimum. Diameter is uncontrolled in L<sub>1</sub> and beyond LL minimum.
8. All four leads.
9. Dimension r (radius) applies to both inside corners of tab.
10. In accordance with ASME Y14.5M, diameters are equivalent to φx symbology.
11. Lead 1 = emitter, lead 2 = base, lead 3 = collector, lead 4 = case (electrically connected).

FIGURE 1. Physical dimensions for 2N918 (TO-72).

MIL-PRF-19500/301L  
w/AMENDMENT 1

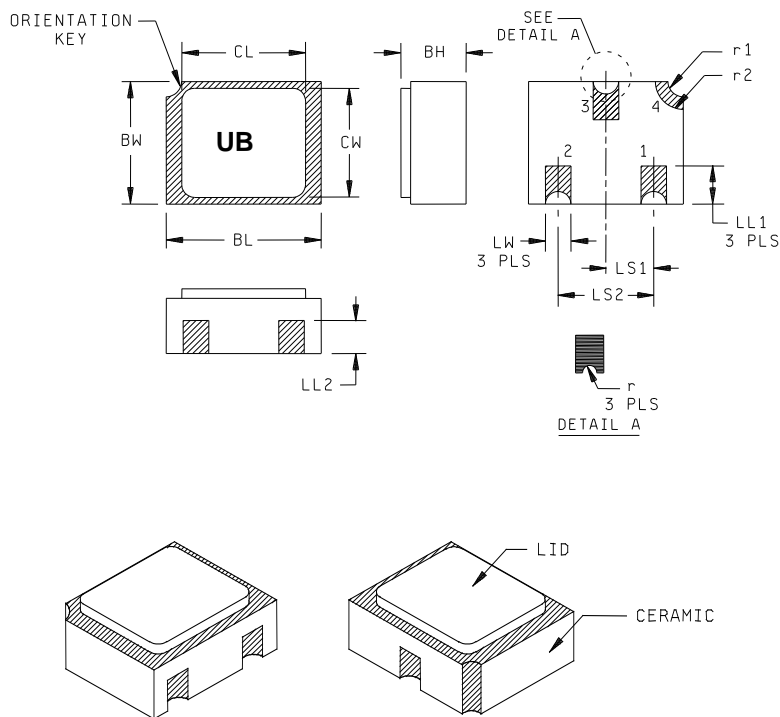

Symbol	Dimensions				Note
	Inches		Millimeters		
	Min	Max	Min	Max	
BH	.046	.056	1.17	1.42	
BL	.115	.128	2.92	3.25	
BW	.085	.108	2.16	2.74	
CL		.128		3.25	
CW		.108		2.74	
LL1	.022	.038	0.56	0.97	
LL2	.017	.035	0.43	0.89	

Symbol	Dimensions				Note
	Inches		Millimeters		
	Min	Max	Min	Max	
LS <sub>1</sub>	.036	.040	0.91	1.02	
LS <sub>2</sub>	.071	.079	1.80	2.01	
LW	.016	.024	0.41	0.61	
r		.008		.203	
r1		.012		.305	
r2		.022		.559	

NOTES:

1. Dimensions are in inches.
2. Millimeters are given for general information only.
3. Hatched areas on package denote metallized areas.
4. Lid material: Kovar.
5. Pad 1 = Base, Pad 2 = Emitter, Pad 3 = Collector, Pad 4 = Shielding connected to the lid.
6. In accordance with ASME Y14.5M, diameters are equivalent to  $\phi$ x symbology.

FIGURE 2. Physical dimensions for 2N918UB, surface mount.

MIL-PRF-19500/301L  
w/AMENDMENT 1

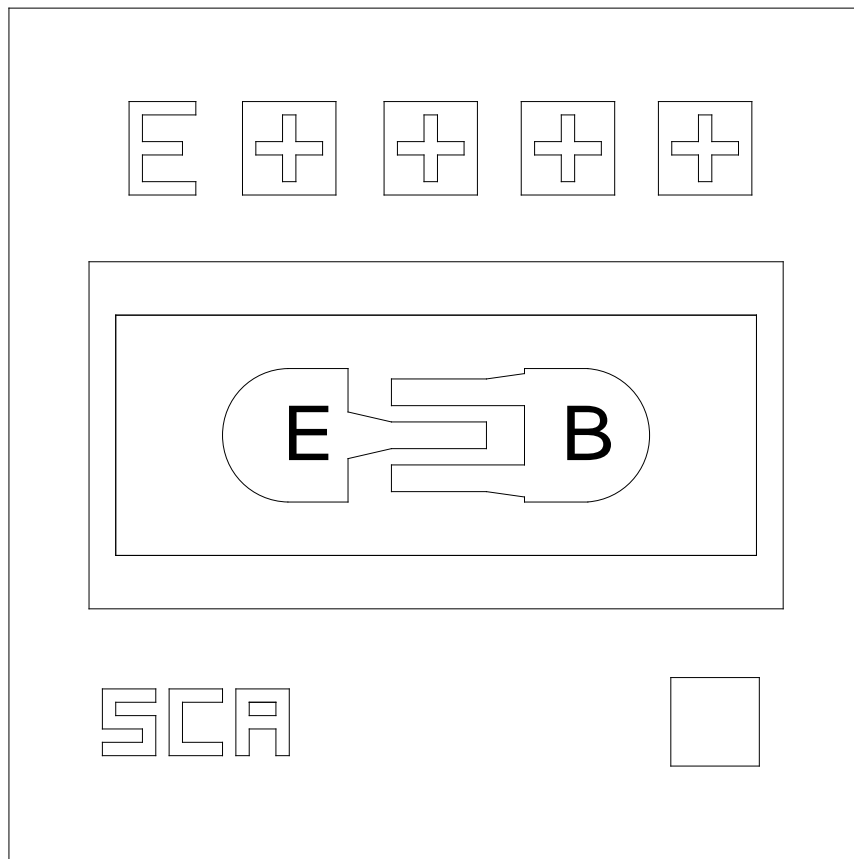

Die size-----	.016 x .016 inch, (0.406 mm X 0.406 mm).
Die thickness---	.008 ±.0016 inch, (0.203 mm ± 0.0406 mm).
Base pad-----	.0027 x .0027 inch, (0.069 mm X 0.069 mm).
Emitter pad-----	.0027 x .0027 inch, (0.069 mm X 0.069 mm).
Back metal-----	Gold, 6,500 ±1,950 Å.
Top metal-----	Aluminum, 17,500 ±2,500 Å.
Back side-----	Collector.
Glassivation---	SiO <sub>2</sub> , 7,500 ±1,500 Å.

FIGURE 3. JANHC and JANKC (A-version) die dimensions.

MIL-PRF-19500/301L  
w/AMENDMENT 1

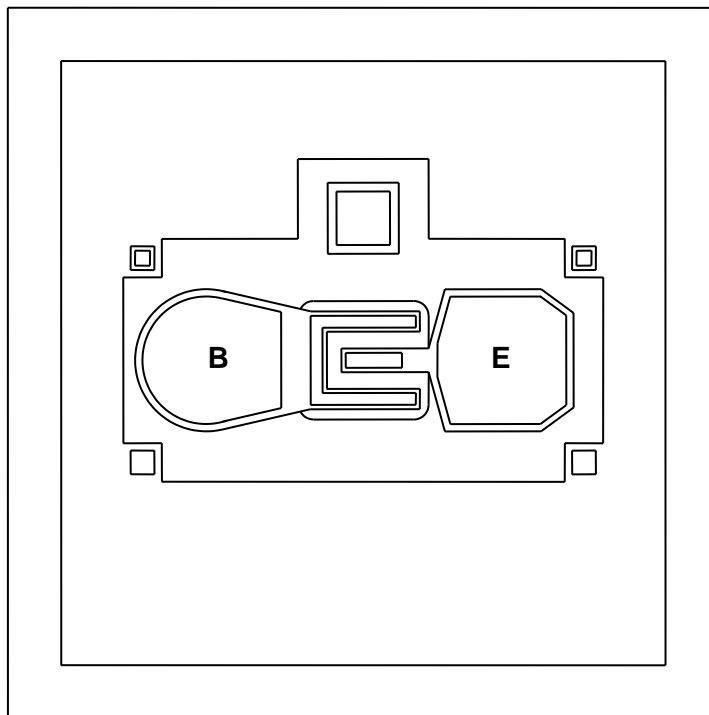

Die size-----	.017 x .017 inch, (0.432 mm X 0.432 mm).
Die thickness---	.010 ±.0016 inch, (0.254 mm ± 0.041 mm).
Base pad-----	.0030 x .0027 inch, (0.076 mm X 0.069 mm).
Emitter pad-----	.00275 x .0027 inch, (0.070 mm X 0.069 mm).
Back metal-----	Gold, 3,500 Å minimum, 5,000 Å nominal.
Top metal-----	Aluminum, 10,000 Å minimum, 12,000 Å nominal.
Back side-----	Collector.

FIGURE 4. JANHCB (B-version) die dimensions.

MIL-PRF-19500/301L  
w/AMENDMENT 1

3.4 Interface and physical dimensions. Interface and physical dimensions shall be as specified in MIL-PRF-19500, and [figure 1](#) (TO-72), 2 (surface mount UB), 3 (die), and 4 (die) herein.

3.4.1 Lead finish. Lead finish shall be solderable in accordance with MIL-PRF-19500, MIL-STD-750, and herein. Where a choice of lead finish is desired, it shall be specified in the acquisition document (see [6.2](#)).

3.5 Radiation hardness assurance (RHA). Radiation hardness assurance requirements, PIN designators, and test levels shall be as defined in MIL-PRF-19500.

3.6 Electrical performance characteristics. Unless otherwise specified herein, the electrical performance characteristics are as specified in [1.3](#), [1.4](#), and [table I](#) herein.

3.7 Electrical test requirements. The electrical test requirements shall be as specified in [table I](#).

3.8 Marking. Marking shall be in accordance with MIL-PRF-19500, except for the UB suffix package. Marking on the UB package shall consist of an abbreviated part number, the date code, and the manufacturers symbol or logo. The prefixes JAN, JANTX, JANTXV, and JANS can be abbreviated as J, JX, JV, and JS respectively. The "2N" prefix and the "UB" suffix can also be omitted. The radiation hardness designator M, D, P, L, R, F, G, or H shall immediately precede (or replace) the device "2N" identifier (depending upon degree of abbreviation required).

3.9 Workmanship. Semiconductor devices shall be processed in such a manner as to be uniform in quality and shall be free from other defects that will affect life, serviceability, or appearance.

#### 4. VERIFICATION

4.1 Classification of inspections. The inspection requirements specified herein are classified as follows:

- a. Qualification inspection (see [4.2](#)).
- b. Screening (see [4.3](#)).
- c. Conformance inspection (see [4.4](#) and tables I, II and III).

4.2 Qualification inspection. Qualification inspection shall be in accordance with MIL-PRF-19500 and as specified herein.

4.2.1 JANHC and JANKC qualification. JANHC and JANKC qualification inspection shall be in accordance with MIL-PRF-19500.

4.2.2 Group E qualification. Group E inspection shall be performed for qualification or re-qualification only. In case qualification was awarded to a prior revision of the specification sheet that did not request the performance of [table III](#) tests, the tests specified in [table IV](#) herein that were not performed in the prior revision shall be performed on the first inspection lot of this revision to maintain qualification.

MIL-PRF-19500/301L  
w/AMENDMENT 1

4.2.2.1 Group E thermal response. With extremely small junction devices such as this one, a true thermal impedance cannot be measured, only calculated. While “thermal response” has been substituted for “thermal impedance” herein, the terms, units, and procedures are essentially unchanged. Each supplier shall submit a thermal response ( $Z_{\theta JX}$ ) histogram of the entire qualification lot. The histogram data shall be taken prior to the removal of devices that are atypical for thermal response. Thermal response curves (from  $Z_{\theta JX}$  test pulse time to  $R_{\theta JX}$  minimum steady-state time) of the best device in the qual lot and the worst device in the qual lot (that meets the supplier proposed screening limit), or from the thermal grouping, shall be submitted. The optimal test conditions and proposed initial thermal response screening limit shall be provided in the qualification report. Data indicating how the optimal test conditions were derived for  $Z_{\theta JX}$  shall also be submitted. The proposed maximum thermal response  $Z_{\theta JX}$  screening limit shall be submitted. The qualifying activity may approve a different  $Z_{\theta JX}$  limit for conformance inspection end-point measurements as applicable. Equivalent data, procedures, or statistical process control plans may be used for part, or all, of the above requirements. The approved thermal response conditions and limit for  $Z_{\theta JX}$  shall be used by the supplier in screening and [table I](#), subgroup 2. The approved thermal resistance conditions for  $R_{\theta JX}$  shall be used by the supplier for conformance inspection. For product families with similar thermal characteristics based on the same physical and thermal die, package, and construction combination (thermal grouping), the supplier may use the same thermal response curves.

4.3 Screening. Screening shall be in accordance with table E-IV of MIL-PRF-19500, and as specified herein. The following measurements shall be made in accordance with [table I](#) herein. Devices that exceed the limits of [table I](#) herein shall not be acceptable.

Screen (see table E-IV of MIL-PRF-19500)	Measurement	
	JANS level	JANTX and JANTXV levels
(1) 3c	Thermal impedance, method 3131 of MIL-STD-750 (see <a href="#">4.3.3</a> ).	Thermal impedance, method 3131 of MIL-STD-750 (see <a href="#">4.3.3</a> ).
9	$I_{CBO1}$ and $h_{FE2}$	
11	$I_{CBO1}$ and $h_{FE2}$ $\Delta I_{CBO1}$ = 100 percent of initial value or 5 nA dc, whichever is greater; $\Delta h_{FE2}$ = $\pm 15$ percent.	$I_{CBO1}$ and $h_{FE2}$
12	See <a href="#">4.3.2</a>	See <a href="#">4.3.2</a>
13	Subgroups 2 and 3 of <a href="#">table I</a> herein; $\Delta I_{CBO1}$ = 100 percent of initial value or 5 nA dc, whichever is greater; $\Delta h_{FE2}$ = $\pm 15$ percent.	Subgroup 2 of <a href="#">table I</a> herein; $\Delta I_{CBO1}$ = 100 percent of initial value or 5 nA dc, whichever is greater; $\Delta h_{FE2}$ = $\pm 20$ percent.

(1) Shall be performed anytime after temperature cycling, screen 3a; TX and TXV levels do not need to be repeated in screening requirements.

4.3.1 Screening (JANHNC and JANKC). Screening of JANHC and JANKC die shall be in accordance with MIL-PRF-19500, “Discrete Semiconductor Die/Chip Lot Acceptance”. Burn-in duration for the JANKC level follows JANS requirements; the JANHC follows JANTX requirements.



MIL-PRF-19500/301L  
w/AMENDMENT 1

4.3.2 Power burn-in conditions. Power burn-in conditions are as follows: 2N918, UB,  $V_{CB} = 5 - 15$  V dc,  $P_T = 200$  mW at  $T_A =$  room ambient as defined in the general requirements of 4.5 in MIL-STD-750. NOTE: No heat sink or forced air cooling on the devices shall be permitted.

4.3.3 Thermal impedance ( $\Delta V_{BE}$  measurements). The  $\Delta V_{BE}$  measurements shall be performed in accordance with method 3131 of MIL-STD-750 using the guidelines in that method for determining  $V_H$ ,  $V_{CE}$ ,  $I_M$ ,  $I_H$ ,  $t_H$ , and  $t_{MD}$ . The  $\Delta V_{BE}$  limit used in screen 3c and table I, subgroup 2 shall be set statistically by the supplier over several die lots and submitted to the qualifying activity for approval.

4.4 Conformance inspection. Conformance inspection shall be in accordance with MIL-PRF-19500 and as specified herein. Group A inspection shall be performed on each subplot.

4.4.1 Group A inspection. Group A inspection shall be conducted in accordance with MIL-PRF-19500 and table I herein.

4.4.2 Group B inspection. Group B inspection shall be conducted in accordance with the tests and conditions specified for subgroup testing in table E-VIa (JANS) and table E-VIb (JAN, JANTX, and JANTXV) of MIL-PRF-19500 and 4.4.2.1 and 4.4.2.2 herein. Electrical measurements (end-points) shall be in accordance with table I, subgroup 2 herein. Delta measurements shall be in accordance with table III herein.

4.4.2.1 Group B inspection, table E-VIa (JANS) of MIL-PRF-19500.

<u>Subgroup</u>	<u>Method</u>	<u>Conditions</u>
B3	2037	Test condition A. All internal leads for each device shall be pulled separately.
B4	1037	$V_{CB} = 10$ V dc, 2,000 cycles, $t_{ON} = t_{OFF} = 3$ minutes, $P_{D(ON)} = P_D$ max rated in accordance with 1.3; $P_{D(OFF)} = 0$ .
B5	1027	$V_{CB} = 10$ V dc; 1,000 hours maximum rated power shall be applied and ambient temperature adjusted to achieve $T_J = +150^\circ\text{C}$ minimum. $n = 45$ , $c = 0$ .

4.4.2.2 Group B inspection, table E-VIb (JAN, JANTX, and JANTXV). Separate samples may be used for each step. In the event of a group B failure, the manufacturer may pull a new sample at double size from either the failed assembly lot or from another assembly lot from the same wafer lot. If the new "assembly lot" option is exercised, the failed assembly lot shall be scrapped.

<u>Step</u>	<u>Method</u>	<u>Conditions</u>
1	1026	Steady-state life: 1,000 hours, $V_{CB} = 10$ V dc, power shall be applied to achieve $T_J = +150^\circ\text{C}$ minimum using a minimum of $P_D = 100$ percent of maximum rated $P_T$ as defined in 1.3; in addition, adjust $T_A$ to achieve $T_J$ . $n = 45$ devices, $c = 0$ .
2	1048	Blocking life: $T_A = +150^\circ\text{C}$ , $V_{CB} = 80$ percent of rated voltage without going over the maximum rated $V_{CEO}$ , 48 hours minimum. $n = 45$ devices, $c = 0$ .
3	1032	High temperature life (non-operating), $t = 340$ hours; $T_A = +200^\circ\text{C}$ . $n = 22$ , $c = 0$ .

MIL-PRF-19500/301L  
w/AMENDMENT 1

4.4.2.3 Group B sample selection. Samples selected from group B inspection shall meet all of the following requirements:

- a. For JAN, JANTX, and JANTXV samples shall be selected randomly from a minimum of three wafers (or from each wafer in the lot) from each wafer lot. For JANS, samples shall be selected from each inspection lot. See MIL-PRF-19500.
- b. Shall be chosen from an inspection lot that has been submitted to and passed [table I](#), subgroup 2 conformance inspection. When the final lead finish is solder or any plating prone to oxidation at high temperature, the samples for life test (subgroups B4 and B5 for JANS, and group B for JAN, JANTX, and JANTXV) may be pulled prior to the application of final lead finish.

4.4.3 Group C inspection. Group C inspection shall be conducted in accordance with the tests and conditions specified for subgroup testing in table E-VII of MIL-PRF-19500, and in [4.4.3.1](#) (JANS) and [4.4.3.2](#) (JAN, JANTX, and JANTXV) herein for group C testing. Electrical measurements (end-points) shall be in accordance with [table I](#), subgroup 2 herein. Delta measurements shall be in accordance with [table III](#) herein.

4.4.3.1 Group C inspection, table E-VII (JANS) of MIL-PRF-19500.

<u>Subgroup</u>	<u>Method</u>	<u>Conditions</u>
C2	2036	Test condition E, not applicable for UB devices.
C5	3131	See <a href="#">1.3</a> herein.
C6	1026	$V_{CB} = 10$ V dc, 1,000 hours; maximum rated power shall be applied and ambient temperature adjusted to achieve $T_j = +150^\circ\text{C}$ minimum. $n = 45$ devices, $c = 0$ . For small lots, $n = 12$ devices, $c = 0$ . The sample size may be increased and the test time decreased as long as the devices are stressed for a total of 45,000 device hours minimum, and the actual time of test is at least 340 hours.

4.4.3.2. Group C inspection, table E-VII (JAN, JANTX, and JANTXV) of MIL-PRF-19500.

<u>Subgroup</u>	<u>Method</u>	<u>Condition</u>
C2	2036	Test condition E; not applicable for UB devices.
C5	3131	See <a href="#">1.3</a> herein.
C6		Not applicable.

4.4.3.3 Group C sample selection. Samples for subgroups in group C shall be chosen at random from any inspection lot containing the intended package type and lead finish procured to the same specification which is submitted to and passes [table I](#) tests for conformance inspection. When the final lead finish is solder or any plating prone to oxidation at high temperature, the samples for C6 life test may be pulled prior to the application of final lead finish. Testing of a subgroup using a single device type enclosed in the intended package type shall be considered as complying with the requirements for that subgroup.

4.4.4 Group D inspection. Conformance inspection for hardness assured JANS, JANTX, and JANTXV types shall include the group D tests specified in [table II](#) herein. These tests shall be performed as required in accordance with MIL-PRF-19500 and method 1019 of MIL-STD-750, for total ionizing dose or method 1017 of MIL-STD-750 for neutron fluence as applicable (see [6.2.e](#) herein), except group D, subgroup 2 may be performed separate from other subgroups. Alternate package options may also be substituted for the testing, provided there is no adverse effect to the fluence profile.

MIL-PRF-19500/301L  
w/AMENDMENT 1

4.4.5 Group E inspection. Group E inspection shall be conducted in accordance with the conditions specified for subgroup testing in appendix E, table E-IX of MIL-PRF-19500 and as specified in table IV herein. Electrical measurements (end-points) shall be in accordance with [table I](#), subgroup 2 herein. Delta measurements shall be in accordance with [table III](#) herein.

4.5 Methods of inspection. Methods of inspection shall be as specified in the appropriate tables and as follows.

4.5.1 Input capacitance. This test shall be conducted in accordance with method 3240 of MIL-STD-750 except that the output capacitor shall be omitted.

4.5.2 Disposition of case lead during electrical measurements. Unless otherwise specified all electrical measurements and operating life test shall be performed with the case lead connected to the emitter.

4.5.3 Noise figure. The noise figure shall be measured using commercially available test equipment and its associated standard test procedures (see [figure 7](#)).

4.5.4 Collector-base time constant. This parameter may be determined by applying an rf signal voltage of 1.0 volt (rms) across the collector-base terminals, and measuring the ac voltage drop ( $V_{eb}$ ) with a high-impedance rf voltmeter across the emitter-base terminals. With  $f = 79.8$  MHz used for the 1.0 volt signal, the following computation applies:  
 $r_b' C_c: (\text{psec}) = 2 \times V_{eb} (\text{millivolts})$

MIL-PRF-19500/301L  
w/AMENDMENT 1

TABLE I. Group A inspection.

Inspection <u>1/</u>	MIL-STD-750		Symbol	Limits		Unit
	Method	Conditions		Min	Max	
<u>Subgroup 1 2/</u>						
Visual and mechanical examination <u>3/</u>	2071					
Solderability <u>3/ 4/</u>	2026	n = 15 leads, c = 0				
Resistance to solvents <u>3/ 4/ 5/</u>	1022	n = 15 devices, c = 0				
Temp cycling <u>3/ 4/</u>	1051	Test condition C, 25 cycles. n = 22 devices, c = 0				
Hermetic seal <u>4/</u> Fine leak Gross leak	1071	n = 22 devices, c = 0 Test conditions G or H Test conditions C or D				
Electrical measurements <u>4/</u>		<a href="#">Table I</a> , subgroup 2				
Bond strength <u>3/ 4/</u>	2037	Precondition T <sub>A</sub> = +250°C at t = 24 hrs or T <sub>A</sub> = +300°C at t = 2 hrs n = 11 wires, c = 0				
Decap internal visual (design verification) <u>4/</u>	2075	n = 4 devices, c = 0				
<u>Subgroup 2</u>						
Thermal impedance <u>6/</u>	3131	See <a href="#">4.3.3</a>	ΔV <sub>BE</sub>			
Collector to base cutoff current	3036	Bias condition D, V <sub>CBO</sub> = 30 V	I <sub>CBO2</sub>		1	μA dc
Breakdown voltage, collector to emitter	3011	Bias condition D, I <sub>C</sub> = 3.0 mA dc	V <sub>(BR)CEO</sub>	15		V dc
Emitter to base cutoff current	3061	Bias condition D, V <sub>EB</sub> = 3 V	I <sub>EBO2</sub>		10	μA dc
Collector to base cutoff current	3036	Bias condition D, V <sub>CB</sub> = 25 V dc	I <sub>CBO1</sub>		10	nA dc
Emitter to base cutoff current	3061	Bias condition D, V <sub>EB</sub> = 2.5 V dc	I <sub>EBO1</sub>		10	nA dc
Forward-current transfer ratio	3076	V <sub>CE</sub> = 10 V dc; I <sub>C</sub> = 500 μA dc	h <sub>FE1</sub>	10		
Forward-current transfer ratio	3076	V <sub>CE</sub> = 1.0 V dc; I <sub>C</sub> = 3.0 mA dc	h <sub>FE2</sub>	20	200	
Forward-current transfer ratio	3076	V <sub>CE</sub> = 10 V dc; I <sub>C</sub> = 10 mA dc	h <sub>FE3</sub>	20		

See footnotes at end of table.

MIL-PRF-19500/301L  
w/AMENDMENT 1

TABLE I. Group A inspection - Continued.

Inspection <u>1/</u>	MIL-STD-750		Symbol	Limits		Unit
	Method	Conditions		Min	Max	
<u>Subgroup 2</u> - Continued.						
Collector to emitter voltage (saturated)	3071	$I_C = 10 \text{ mA dc}; I_B = 1.0 \text{ mA dc}$	$V_{CE(sat)}$		0.4	V dc
Base to emitter voltage (saturated)	3066	Test condition A; $I_C = 10 \text{ mA dc}; I_B = 1.0 \text{ mA dc}$	$V_{BE(sat)}$		1.0	V dc
<u>Subgroup 3</u>						
High temperature operation		$T_A = +150^\circ\text{C}$				
Collector to base cutoff current	3036	Bias condition D, $V_{CB} = 25 \text{ V dc}$	$I_{CBO2}$		1.0	$\mu\text{A dc}$
Low-temperature operation		$T_A = -55^\circ\text{C}$				
Forward-current transfer ratio	3076	$V_{CE} = 1.0 \text{ V dc}; I_C = 3.0 \text{ mA dc}$	$h_{FE4}$	10		
<u>Subgroup 4</u>						
Open circuit output capacitance	3236	$V_{CB} = 0 \text{ V dc}; I_E = 0, 100 \text{ kHz} \leq f \leq 1 \text{ MHz}$	$C_{obo1}$		3.0	pF
Open circuit output capacitance	3236	$V_{CB} = 10 \text{ V dc}; I_E = 0, 100 \text{ kHz} \leq f \leq 1 \text{ MHz}$	$C_{obo2}$		1.7	pF
Input capacitance (output open circuited)	3240	$V_{EB} = 0.5 \text{ V dc}; I_C = 0, 100 \text{ kHz} \leq f \leq 1 \text{ MHz}$	$C_{ibo}$		2.0	pF
Magnitude of common emitter, small-signal short-circuit forward current transfer ratio	3306	$V_{CE} = 10 \text{ V dc}; I_C = 4.0 \text{ mA}, f = 100 \text{ MHz}$	$ h_{FE} $	6.0	18	
Noise figure		$V_{CE} = 6 \text{ V dc}; I_C = 1.0 \text{ mA dc}; f = 60 \text{ MHz}; g_s = 2.5 \text{ mmho}$ (see 4.5.2, 4.5.3, and figure 7)	NF		6.0	dB
Small-signal power gain	3256	$V_{CB} = 12 \text{ V dc}; I_C = 6.0 \text{ mA dc}; f = 200 \text{ MHz}$ ; (see figure 8)	$G_{pe}$	15		dB
Collector-base time constant		$V_{CB} = 10 \text{ V dc}; I_E = -4.0 \text{ mA dc}; f = 79.8 \text{ MHz}$ (see 4.5.2 and 4.5.4)	$r_b' C_c$		25	ps

See footnotes at end of table.

MIL-PRF-19500/301L  
w/AMENDMENT 1

TABLE I. Group A inspection - Continued.

Inspection <u>1/</u>	MIL-STD-750		Symbol	Limits		Unit
	Method	Conditions		Min	Max	
<u>Subgroup 4</u> - Continued.						
Oscillator power output		$V_{CB} = 15 \text{ V dc}; I_C = 8.0 \text{ mA dc}; f \geq 500 \text{ MHz}$ (see <a href="#">figure 9</a> )	$P_o$	30		mW
Collector efficiency		$V_{CB} = 15 \text{ V dc}; I_C = 8.0 \text{ mA dc}; f \geq 500 \text{ MHz}$ (see <a href="#">figure 9</a> )	$\eta$	25		%
<u>Subgroup 5</u>						
Not applicable						

1/ For sampling plan (unless otherwise specified see MIL-PRF-19500.

2/ For resubmission of failed subgroup 1, double the sample size of the failed test or sequence of tests. A failure in [table I](#), subgroup 1 shall not require retest of the entire subgroup. Only the failed test shall be rerun upon submission.

3/ Separate samples may be used.

4/ Not required for JANS devices.

5/ Not required for laser marked devices.

6/ This test required for the following end-point measurement only:

Group B, steps 2 and 3 (JANTX and JANTXV).

Group B, subgroups 3, 4, and 5 (JANS).

Group C, subgroups 2 and 6.

Group E, subgroups 1 and 2.

MIL-PRF-19500/301L  
w/AMENDMENT 1

TABLE II. Group D inspection and end-point limits.

Inspection <u>1/ 2/ 3/</u>	MIL-STD-750		Symbol	Limits		Unit
	Method	Conditions		Min	Max	
<u>Subgroup 1 4/</u>						
Neutron irradiation	1017	Neutron exposure $V_{CES} = 0$ V				
Collector to base cutoff current	3036	Bias condition D, $V_{CBO} = 30$ V	$I_{CBO2}$		2	$\mu$ A dc
Breakdown voltage, collector to emitter	3011	Bias condition D; $I_C = 3.0$ mA dc	$V_{(BR)CEO}$	15		V dc
Emitter to base cutoff current	3061	Bias condition D, $V_{EB} = 3$ V	$I_{EBO2}$		20	$\mu$ A dc
Collector to base cutoff current	3036	Bias condition D; $V_{CB} = 25$ V dc	$I_{CBO1}$		20	nA dc
Emitter to base cutoff current	3061	Bias condition D, $V_{EB} = 2.5$ V dc	$I_{EBO1}$		20	nA dc
Forward-current transfer ratio	3076	$V_{CE} = 10$ V dc, $I_C = 500$ $\mu$ A dc	$[h_{FE1}]$	[5]		
Forward-current transfer ratio	3076	$V_{CE} = 1.0$ V dc, $I_C = 3.0$ mA dc	$[h_{FE2}]$	[10]	200	
Forward-current transfer ratio	3076	$V_{CE} = 10$ V dc, $I_C = 10$ mA dc	$[h_{FE3}]$	[10]		
Collector to emitter voltage (saturated)	3071	$I_C = 10$ mA dc, $I_B = 1.0$ mA dc	$V_{CE(sat)}$		0.46	V dc
Base to emitter voltage (saturated)	3066	Test condition A; $I_C = 10$ mA; $I_B = 1.0$ mA	$V_{BE(sat)}$		1.15	V dc

See footnotes at end of table.

MIL-PRF-19500/301L  
w/AMENDMENT 1

TABLE II. Group D inspection and end-point limits - Continued.

Inspection <u>1/</u> <u>2/</u> <u>3/</u>	MIL-STD-750		Symbol	Limits		Unit
	Method	Conditions		Min	Max	
<u>Subgroup 2</u>						
Steady-state total dose irradiation	1019	Gamma exposure $V_{ECS} = 12$ V				
Collector to base cutoff current	3036	Bias condition D, $V_{CBO} = 30$ V	$I_{CBO2}$		2	$\mu$ A dc
Breakdown voltage, collector to emitter	3011	Bias condition D; $I_C = 3.0$ mA dc	$V_{(BR)CEO}$	15		V dc
Emitter to base cutoff current	3061	Bias condition D, $V_{EB} = 3$ V	$I_{EBO2}$		20	$\mu$ A dc
Collector to base cutoff current	3036	Bias condition D; $V_{CB} = 25$ V dc	$I_{CBO1}$		20	$\eta$ A dc
Emitter to base cutoff current	3061	Bias condition D, $V_{EB} = 2.5$ V dc	$I_{EBO1}$		20	$\eta$ A dc
Forward-current transfer ratio	3076	$V_{CE} = 10$ V dc, $I_C = 500$ $\mu$ A dc	$[h_{FE1}]$	[5]		
Forward-current transfer ratio	3076	$V_{CE} = 1.0$ V dc, $I_C = 3.0$ mA dc	$[h_{FE2}]$	[10]	200	
Forward-current transfer ratio	3076	$V_{CE} = 10$ V dc, $I_C = 10$ mA dc	$[h_{FE3}]$	[10]		
Collector to emitter voltage (saturated)	3071	$I_C = 10$ mA dc, $I_B = 1.0$ mA dc	$V_{CE(sat)}$		0.46	V dc
Base to emitter voltage (saturated)	3066	Test condition A; $I_C = 10$ mA; $I_B = 1.0$ mA	$V_{BE(sat)}$		1.15	V dc

1/ Tests to be performed on all devices receiving radiation exposure.

2/ For sampling plan, see MIL-PRF-19500.

3/ Electrical characteristics apply to the corresponding AL, UA, UB, and UBC suffix versions unless otherwise noted.

4/ See 6.2.e herein.

5/ See method 1019 of MIL-STD-750, for how to determine  $[h_{FE}]$  by first calculating the delta ( $1/h_{FE}$ ) from the pre- and post-radiation  $h_{FE}$ . Notice the  $[h_{FE}]$  is not the same as  $h_{FE}$  and cannot be measured directly. The  $[h_{FE}]$  value can never exceed the pre-radiation minimum  $h_{FE}$  that it is based upon.



MIL-PRF-19500/301L  
w/AMENDMENT 1

TABLE III. Groups B, C, and E delta electrical measurements. 1/ 2/ 3/ 4/

Step	Inspection	MIL-STD-750		Symbol	Limits		Unit
		Method	Conditions		Min	Max	
1.	Collector-base cutoff current	3036	Bias condition D; $V_{CB} = 25$ V dc	$\Delta I_{CBO1}$ 3/	100 percent of initial value or 5 nA dc, whichever is greater.		
2.	Forward-current transfer ratio	3076	$V_{CE} = 1.0$ V dc; $I_C = 3.0$ mA dc	$\Delta h_{FE2}$ 3/	$\pm 25$ percent change from initial reading.		
3.	Collector-emitter voltage (saturated)	3071	$I_C = 10$ mA dc; $I_B = 1.0$ mA dc	$\Delta V_{CE(sat)}$ 3/	$\pm 50$ mV dc change from previously measured value.		

1/ The delta electrical measurements for table E-VIa (JANS) of MIL-PRF-19500 are as follows:

- a. Subgroup 4, see [table III](#) herein, step 3.
- b. Subgroup 5, see [table III](#) herein, steps 1, 2, and 3.

2/ The delta measurements for table E-VII of MIL-PRF-19500 are as follows: Subgroup 6, see [table III](#) herein, steps 1, 2, and 3 for JANS level.

3/ The delta measurements for table E-IX of MIL-PRF-19500 and [table IV](#) herein are as follows: Subgroups 1 and 2, see [table III](#) herein, steps 1, 2, and 3, all levels.

4/ Devices which exceed the [table I](#) limits for this test shall not be acceptable.

MIL-PRF-19500/301L  
w/AMENDMENT 1

TABLE IV. Group E inspection (all quality levels) - for qualification or re-qualification only.

Inspection	MIL-STD-750		Qualification
	Method	Conditions	
<u>Subgroup 1</u>			45 devices c = 0
Temperature cycling (air to air)	1051	Test condition C, 500 cycles.	
Hermetic seal Fine leak Gross leak	1071		
Electrical measurements		See <a href="#">table I</a> , subgroup 2 and <a href="#">table III</a> herein.	
<u>Subgroup 2</u>			45 devices c = 0
Intermittent life	1037	Intermittent operation life: $V_{CB} = 10$ V dc; 6,000 cycles, $t_{ON} = t_{OFF} = 3$ minutes, $P_{D(ON)} = P_D$ max rated in accordance with <a href="#">1.3</a> ; $P_{D(OFF)} = 0$ .	
Electrical measurements		See <a href="#">table I</a> , subgroup 2 and <a href="#">table III</a> herein.	
<u>Subgroup 4</u>			
Thermal impedance curves		See <a href="#">4.2.2.1</a> .	
<u>Subgroup 5</u>			
Not applicable			
<u>Subgroup 6</u>			11 devices
ESD	1020		
<u>Subgroup 8</u>			45 devices c = 0
Reverse stability	1033	Condition B.	

**Maximum Thermal Impedance**

JAN2N913 TO-72, Ta=25C, 17x17 CVW Chip

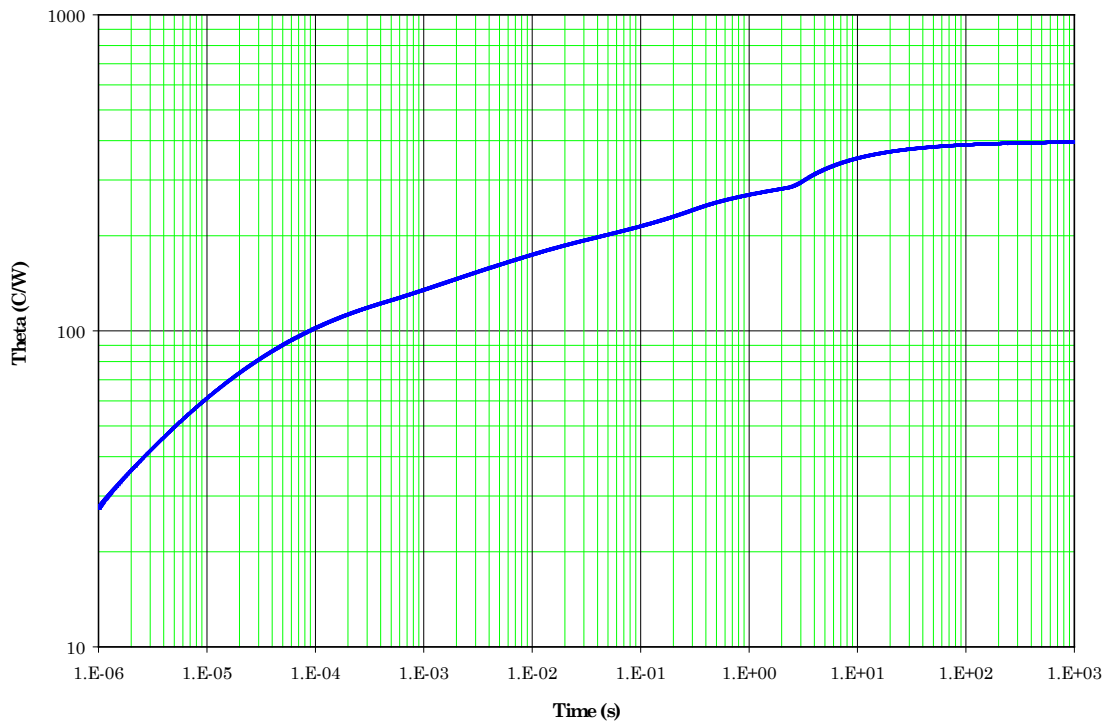

Thermal Impedance Curve, Ta=25C° Free Air, Calculated. Thermal resistance = 400C°/W.

FIGURE 5. Thermal impedance graph ( $R_{\theta JA}$ ) for 2N918 (TO-72).

### Maximum Thermal Impedance

2N918UB 17x17 Chip in UB Package,  $T_{sp}=25^{\circ}\text{C}$ ,  $P_d(\text{max})=200\text{mW}$  at  $25^{\circ}\text{C}$ .

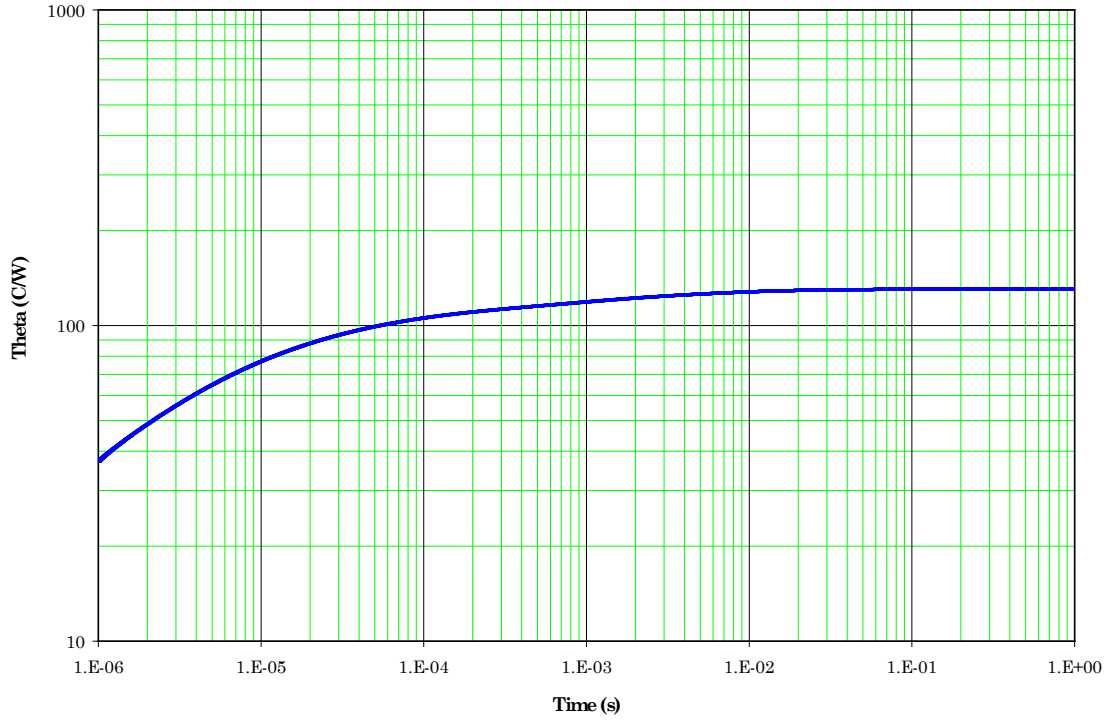

Thermal Impedance Curve,  $T_{sp}=25^{\circ}\text{C}$ , Calculated. Thermal resistance =  $130^{\circ}\text{C}/\text{W}$ .

FIGURE 6. Thermal impedance graph ( $R_{\theta JSP}$ ) for 2N918UB (UB).

MIL-PRF-19500/301L  
w/AMENDMENT 1

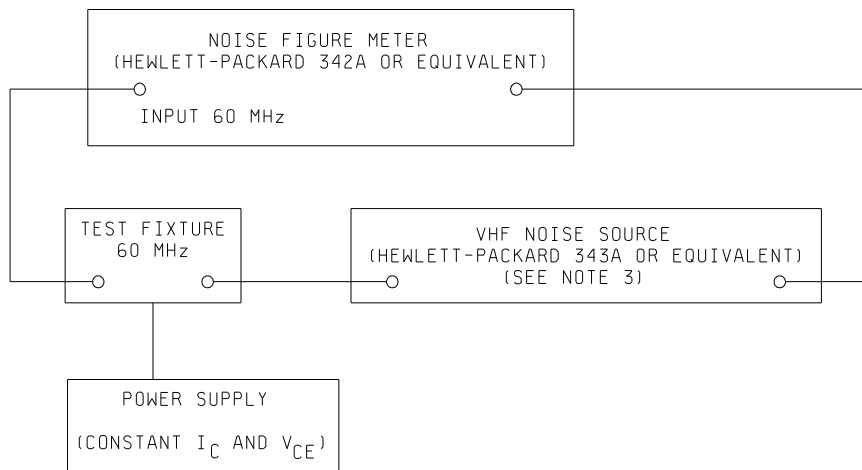

NOTES:

1. The test fixture shall consist of a 60 MHz tuned amplifier and suitable biasing circuits. It should be constructed utilizing very high-frequency design techniques.
2. The effective source susceptance should be tuned for each device being tested to obtain minimum noise figure.
3. The HP-343A has a 50-ohm output resistance, therefore a suitable impedance transformer must be used to obtain an effective source conductance of 2.5 mmho at the transistor with minimum losses.

FIGURE 7. Block diagram for noise-figure test.

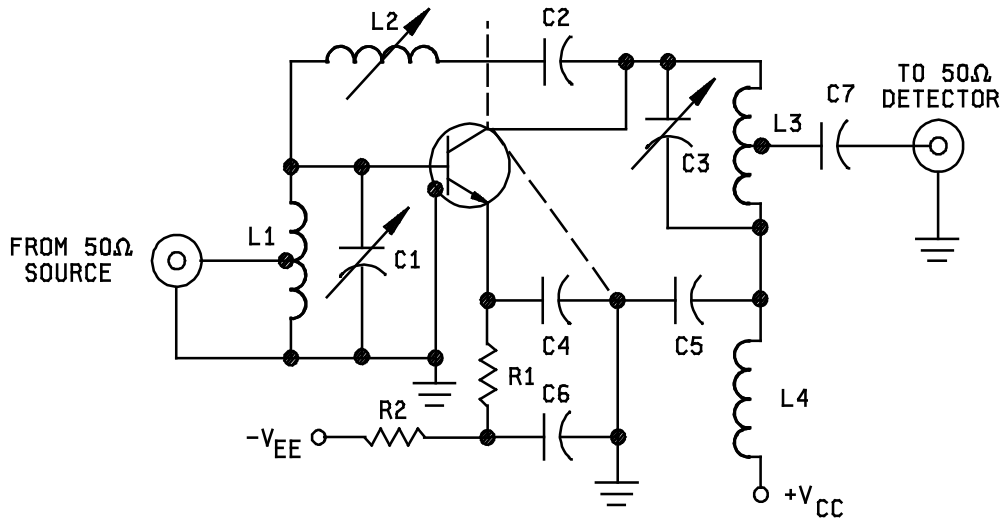

NEUTRALIZATION PROCEDURE:

- Connect a 200 MHz signal generator (with a 50 ohm output impedance) to the input terminals of the amplifier and connect a 50 ohm rf voltmeter to the output terminals of the amplifier.
- Apply  $V_{EE}$  and  $V_{CC}$  to obtain the specified test conditions.
- Adjust the output of the signal generator to approximately 10 millivolts and tune C1 and C3 for maximum output.
- Interchange the connections to the signal generator and rf voltmeter and with sufficient signal applied at the output terminals, tune L2 for a minimum indication on the rf voltmeter.
- Repeat this sequence until optimum settings are obtained for all variables.

CIRCUIT-COMPONENT INFORMATION:

- C1: 3-12 pF  
 C2 and C7: 1,000 pF  
 C3: 1.5 - 7.5 pF  
 C4 and C5: 0.01  $\mu$ F  
 C6: 0.05  $\mu$ F  
 L1:  $3\frac{1}{2}$  T No. 16 AWG .313 inch (7.95 mm) ID, .438 inch (11.13 mm) length, turns ratio  $\cong$  2 to 1  
 L2: 0.4 - 0.65  $\mu$ h, Miller No. 4303 (or equal)  
 L3: 8 T No. 16 AWG, .125 inch (3.18 mm) ID, .875 inch (22.23 mm) length, turns ratio  $\cong$  8 to 1  
 L4: 200 MHz RFC  
 R1: 100  $\Omega$   
 R2: 1 k $\Omega$

FIGURE 8. Small-signal power gain.

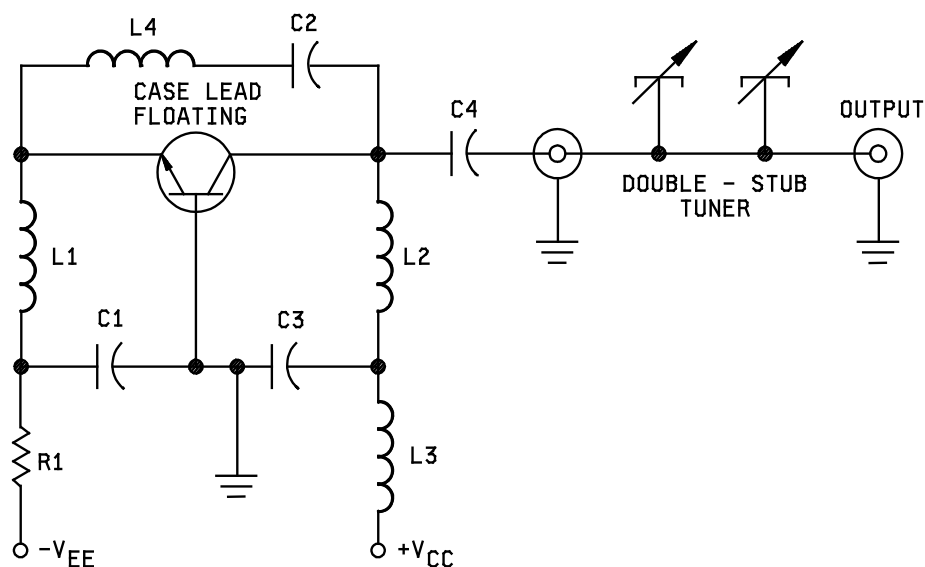

**OSCILLATOR ADJUSTMENT PROCEDURE:**

Measurement of  $P_o$  shall be made in this circuit or a suitable equivalent. The circuit adjustment procedure is as follows:

- Set  $V_{CC}$  and  $V_{EE}$  to obtain the specified test conditions.
- Adjust the stub tuner to obtain the maximum output at the specified frequency of oscillation.
- Check  $I_C$  and reset if necessary.
- Read  $P_o$ .

NOTE: Collector efficiency ( $\eta$ ), may be determined as follows:

$$\eta \text{ in } \% \frac{P_o}{120} \times 100 \quad \text{where } P_o \text{ is in milliwatts.}$$

**CIRCUIT-COMPONENT INFORMATION:**

- C1 and C3: 1,000 pF
- C2: 50 pF
- C4: 75 pF
- R1: 2.2 k $\Omega$
- L1 and L3: 500 mC RFC
- L2: 2 turns No. 16 AWG, .375 inch (9.523 mm) OD, 1.250 inches (31.75 mm) length
- L4: 9 turns No. 22 AWG, .188 inch (4.78 mm) OD, .500 inch (12.70 mm) length

Double-stub tuner consists of the following commercially available components:

- 2 GR Type 874 TEE (or equivalent).
- 1 GR Type 874-D20 adjustable stub (or equivalent).
- 1 GR Type 874-LA adjustable line (or equivalent).
- 1 GR Type 874-WN3 short-circuit termination (or equivalent).

FIGURE 9. Oscillator power output.

MIL-PRF-19500/301L  
w/AMENDMENT 1

5. PACKAGING

5.1 Packaging. For acquisition purposes, the packaging requirements shall be as specified in the contract or order (see 6.2). When packaging of materiel is to be performed by DoD or in-house contractor personnel, these personnel need to contact the responsible packaging activity to ascertain packaging requirements. Packaging requirements are maintained by the Inventory Control Point's packaging activities within the Military Service or Defense Agency, or within the Military Service's system commands. Packaging data retrieval is available from the managing Military Department's or Defense Agency's automated packaging files, CD-ROM products, or by contacting the responsible packaging activity.

6. NOTES

(This section contains information of a general or explanatory nature that may be helpful, but is not mandatory. The notes specified in MIL-PRF-19500 are applicable to this specification.)

6.1 Intended use. Semiconductors conforming to this specification are intended for original equipment design applications and logistic support of existing equipment.

6.2 Acquisition requirements. Acquisition documents should specify the following:

- a. Title, number, and date of this specification.
- b. Packaging requirements (see 5.1).
- c. Lead finish (see 3.4.1).
- d. Product assurance level and type designator.
- e. For acquisition of RHA designed devices, [table II](#), subgroup 1 testing of group D is optional. If subgroup 1 testing is desired, it must be specified in the contract.

6.3 Qualification. With respect to products requiring qualification, awards will be made only for products which are, at the time of award of contract, qualified for inclusion in Qualified Manufacturers List (QML 19500) whether or not such products have actually been so listed by that date. The attention of the contractors is called to these requirements, and manufacturers are urged to arrange to have the products that they propose to offer to the Federal Government tested for qualification in order that they may be eligible to be awarded contracts or orders for the products covered by this specification. Information pertaining to qualification of products may be obtained from DLA Land and Maritime, ATTN: VQE, P.O. Box 3990, Columbus, OH 43218-3990 or e-mail [vqe.chief@dla.mil](mailto:vqe.chief@dla.mil). An online listing of products qualified to this specification may be found in the Qualified Products Database (QPD) at <https://assist.daps.dla.mil>.

6.4 Suppliers of JANHC and JANKC die. The qualified JANHC and JANKC suppliers with the applicable letter version (example JANHCA2N918) will be identified on the QML.

Die ordering information		
PIN	Manufacturer	
	34156	43611
2N918 2N918	JANHCA2N918 JANKCA2N918	JANHCB2N918



MIL-PRF-19500/301L  
w/AMENDMENT 1

\* 6.5 Amendment notations. The margins of this specification are marked with asterisks to indicate modifications generated by this amendment. This was done as a convenience only and the Government assumes no liability whatsoever for any inaccuracies in these notations. Bidders and contractors are cautioned to evaluate the requirements of this document based on the entire content irrespective of the marginal notations and relationship to the last previous issue.

Custodians:

Army - CR  
Navy - EC  
Air Force - 85  
NASA - NA  
DLA - CC

Preparing activity:

DLA - CC

(Project 5961-2011-079)

Review activities:

Army - AR, MI  
Navy - AS, MC, SH  
Air Force - 19, 99

NOTE: The activities listed above were interested in this document as of the date of this document. Since organizations and responsibilities can change, you should verify the currency of the information above using the ASSIST Online database at <https://assist.daps.dla.mil>.