

MILITARY SPECIFICATION SHEET
CAPACITORS, FIXED, CERAMIC DIELECTRIC (GENERAL PURPOSE),
STYLE CK61

This specification is approved for use by all Departments and Agencies of the Department of Defense.

The requirements for acquiring the product described herein shall consist of this specification sheet and [MIL-C-11015](#).

INACTIVE FOR NEW DESIGN AFTER 31 MARCH 1999.
FOR REPLACEMENT PURPOSES ONLY.

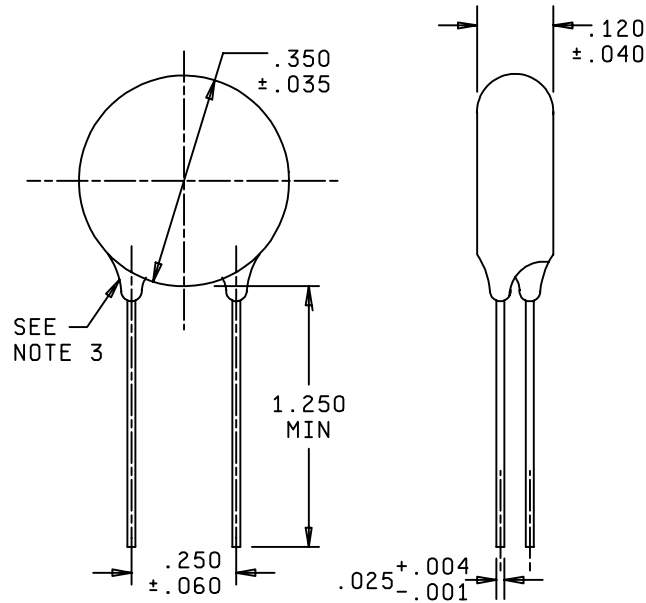

| Inches | mm |
|--------|-------|
| .001 | .03 |
| .004 | .10 |
| .025 | .64 |
| .035 | .89 |
| .040 | 1.02 |
| .060 | 1.52 |
| .120 | 3.05 |
| .250 | 6.35 |
| .350 | 8.89 |
| 1.250 | 31.75 |

NOTES:

1. Dimensions are in inches.
2. Metric equivalents are given for general information only.
3. Insulating coating shall not extend more than .125 (3.18 mm) along lead wires measured from a tangent to the coating surface drawn perpendicular to the lead wires.

FIGURE 1. Dimensions and configuration.

MIL-C-11015/10F
W/AMENDMENT 1

TABLE I. Style CK61 characteristics.

| PIN ^{1/} | Rated voltage | Rated temperature and voltage-temperature limits | Capacitance | Capacitance tolerance |
|-------------------|---------------|--|-------------|-----------------------|
| | Volts, dc | | pF | |
| CK61CZ2R2-- | 500 | CZ | 2.2 | K, M |
| CK61CZ3R3-- | 500 | CZ | 3.3 | K, M |
| CK61CZ4R7-- | 500 | CZ | 4.7 | K, M |
| CK61CZ6R8-- | 500 | CZ | 6.8 | K, M |
| CK61CZ100-- | 500 | CZ | 10 | K, M |
| CK61CZ150-- | 500 | CZ | 15 | K, M |
| CK61CZ220-- | 500 | CZ | 22 | K, M |
| CK61CZ330-- | 500 | CZ | 33 | K, M |
| CK61CZ470-- | 500 | CZ | 47 | K, M |
| CK61CZ680-- | 500 | CZ | 68 | K, M |
| CK61CZ101-- | 500 | CZ | 100 | K, M |
| CK61CZ151-- | 500 | CZ | 150 | K, M |
| CK61BX221-- | 500 | BX | 220 | K, M |
| CK61CZ221-- | 500 | CZ | 220 | K, M |
| CK61BX331-- | 500 | BX | 330 | K, M |
| CK61CZ331-- | 500 | CZ | 330 | K, M |
| CK61BX471-- | 500 | BX | 470 | K, M |
| CK61CZ471-- | 500 | CZ | 470 | K, M |
| CK61BX681-- | 500 | BX | 680 | K, M |
| CK61AW222M- | 500 | AW | 2,200 | M |

^{1/} Where applicable, the complete PIN will include an additional symbol to indicate capacitance tolerance. The PIN will also include the letter "E" to indicate an epoxy coated capacitor (when applicable) or "-" will be deleted for wax impregnated case.

REQUIREMENTS

Design and construction:

Dimensions and configuration - See figure 1.

Case type - Disk, wax impregnated or epoxy coated (E).

Capacitance value - See table I.

Capacitance tolerance - ± 10 percent (K) or ± 20 percent (M) as shown in table I.

* Rated temperature - -55°C to $+85^{\circ}\text{C}$ (A), or -55°C to $+125^{\circ}\text{C}$ (B), or -55°C to $+150^{\circ}\text{C}$ (C), as shown in table I.

Dielectric withstanding voltage(DWV): In accordance with MIL-C-11015.

Dielectric:

Test voltage - 250 percent of rated voltage.

Body insulation:

Test potential - 1,300 volts dc.

MIL-C-11015/10F
W/AMENDMENT 1

Barometric pressure (reduced): In accordance with MIL-C-11015 and [method 105 of MIL-STD-202](#), 0.82 inch of mercury (80,000 ft).

Test potential - 150 percent of rated voltage.

Insulation resistance (IR): In accordance with MIL-C-11015 and [method 302 of MIL-STD-202](#), condition B. 200,000 megohms, minimum.

Dissipation factor (DF): 2.0 percent maximum.

Vibration, high frequency: In accordance with MIL-C-11015 and [method 204 of MIL-STD-202](#), condition D (20 g's).

Thermal shock and immersion: In accordance with MIL-C-11015.

DWV - 250 percent of rated voltage.

IR - 150,000 megohms, minimum.

Salt spray (corrosion): Not applicable.

Terminal strength: In accordance with MIL-C-11015.

Moisture resistance: In accordance with MIL-C-11015.

DWV - 250 percent of rated voltage.

IR - 150,000 megohms, minimum.

Cap. - Within tolerance of table I value.

Solderability: In accordance with MIL-C-11015. 2 terminals.

Resistance to soldering heat: In accordance with MIL-C-11015.

IR - 200,000 megohms, minimum.

Δ Cap. - ± 5 percent of initial measurement.

Δ DF - 0.5 percent, maximum.

Voltage-temperature limits: In accordance with MIL-C-11015.

Life (at elevated ambient temperature): In accordance MIL-C-11015.

Test potential - 200 percent of rated voltage.

DWV - 250 percent of rated voltage. (at 25°C).

IR - 100,000 megohms, minimum (at high temperature and 25°C).

Cap. - Within tolerance of table I value (at 25°C).

DF - 2.0 percent, maximum.

Marking: In accordance with MIL-C-11015.

MIL-C-11015/10F
W/AMENDMENT 1

- * Referenced documents. In addition to [MIL-C-11015](#), this specification sheet references the following document:

[MIL-STD-202](#)

- * Changes from previous issue. The margins of this specification sheet are marked with asterisks to indicate where changes from the previous issue were made. This was done as a convenience only and the Government assumes no liability whatsoever for any inaccuracies in these notations. Bidders and contractors are cautioned to evaluate the requirements on this document on the entire content irrespective of the marginal notations and relationship to the last previous issue.

Custodians:

Army - CR
Navy - EC
Air Force - 11
DLA - CC

Preparing activity:
DLA - CC

(Project 5910-2007-022)

Review activities:

Army - MI
Navy - AS, OS, SH
Air Force - 19

- * NOTE: The activities listed above were interested in this document as of the date of this document. Since organizations and responsibilities can change, you should verify the currency of the information above using the ASSIST Online database at <http://assist.daps.mil>.