

INCH-POUND

MIL-PRF-39016/18H
1 April 2005
SUPERSEDING
MIL-PRF-39016/18G
20 July 1988

PERFORMANCE SPECIFICATION SHEET

RELAYS, ELECTROMAGNETIC, ESTABLISHED RELIABILITY, DPDT,
LOW LEVEL TO 1.0 AMPERE WITH INTERNAL DIODE FOR COIL
TRANSIENT SUPPRESSION, TERMINALS 0.100-INCH GRID PATTERN

This specification sheet is approved for use by all Departments
and Agencies of the Department of Defense.

The complete requirements for acquiring the relays described herein shall
consist of this specification sheet and the latest issue of MIL-PRF-39016.

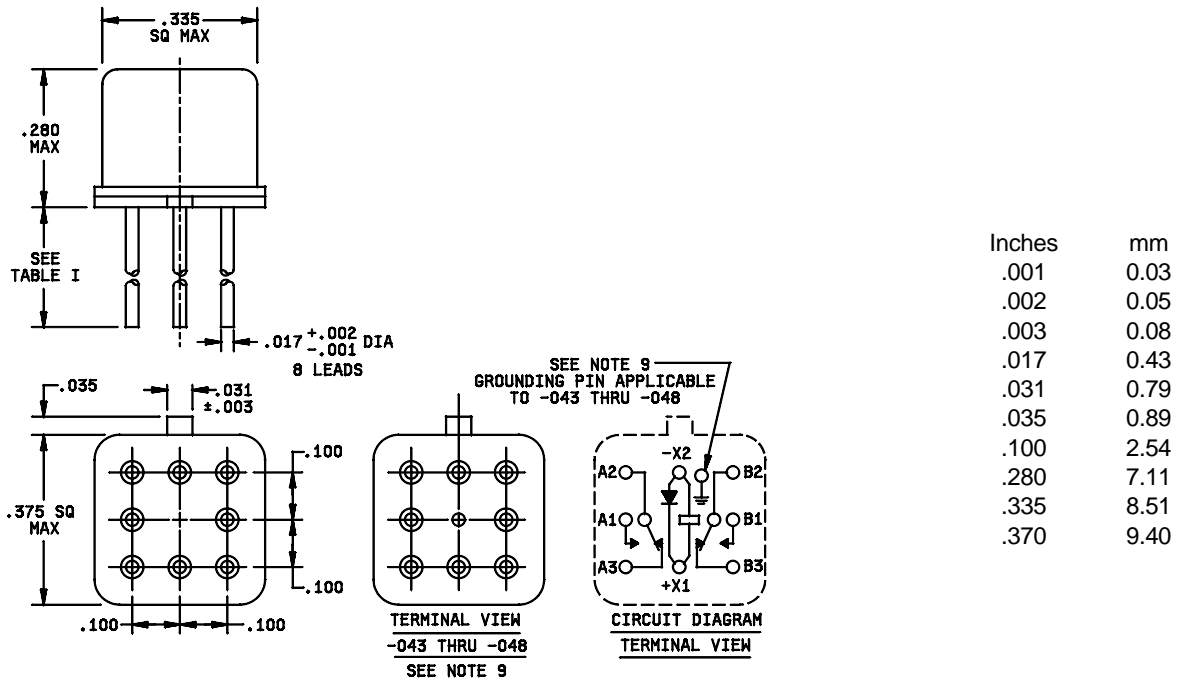

NOTES:

1. Dimensions are in inches.
2. Metric equivalents are given for general information only.
3. Unless otherwise specified, tolerance is $\pm .010$ (0.25 mm).
4. Terminal numbers shown above are for reference only. Numbers do not appear on relay.
5. Relays shall have a plus (+) sign placed on the circuit diagram as shown.
6. Coil symbol optional in accordance with MIL-STD-1285.
7. Circuit diagram shown on part is the terminal view.
8. See table I for lead lengths.
9. M39016/18-043 through M39016/18-048 shall be supplied with a case grounding pin welded to the relay header as shown.

FIGURE 1. Dimensions and configuration.

MIL-PRF-39016/18H

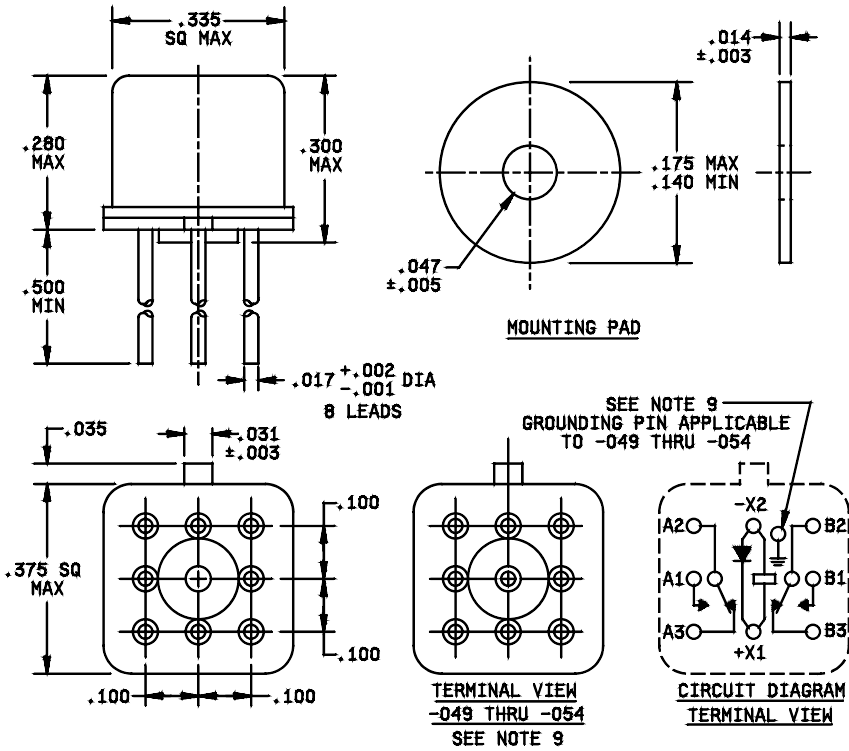

Inches	mm
.001	0.03
.002	0.05
.003	0.08
.005	0.13
.014	0.36
.017	0.43
.031	0.79
.035	0.89
.047	1.19
.100	2.54
.170	4.32
.280	7.11
.300	7.62
.335	8.51
.370	9.40
.500	12.70

NOTES:

1. Dimensions are in inches.
2. Metric equivalents are given for general information only.
3. Unless otherwise specified, tolerance is ± 0.010 (0.25 mm).
4. Terminal numbers shown above for reference only. Numbers do not appear on relay.
5. Relays shall have a plus (+) sign placed on the circuit diagram as shown.
6. Coil symbol optional in accordance with MIL-STD-1285.
7. Circuit diagram shown on part is the terminal view.
8. Spacer mounting pad shall be a polyester film per MIL-I-631, Type G, Class I.
9. M39016/18-049 through -054 shall be supplied with a case grounding pin welded to the relay header as shown.

FIGURE 2. Dimensions and configuration (relay with spacer mounting pad).

REQUIREMENTS:

CONTACT DATA:

Load ratings:

High level (relay case grounded):

Resistive:

1.0 ampere at 28 V dc.

250 milliamperes at 115 V ac 60 and 400 Hz case not grounded.

100 milliamperes at 115 V ac 60 and 400 Hz case grounded.

Inductive load: 0.2 ampere at 28 V dc with 0.32 henry inductance.

Lamp: 0.10 ampere at 28 V dc.

Low level: 10 to 50 μ A at 10 to 50 mV dc or peak ac.

Intermediate current: Applicable.

Contact resistance or voltage drop:

Initial: 0.10 ohm maximum (0.110 ohm maximum with spacer mounting pad).

High level:

During life: Not more than 5 percent of open circuit voltage.

After life: 0.20 ohm maximum (0.210 ohm maximum with spacer mounting pad).

Low level:

During life: 100 ohms maximum.

After life: 0.15 ohm maximum (0.160 ohm maximum with spacer mounting pad).

Intermediate current:

During: 3 ohms maximum.

After: 0.20 ohm maximum (0.210 ohm maximum with spacer mounting pad).

Contact bounce: 1.5 milliseconds maximum (applicable to failure rate level "L").

Contact stabilization time: 2.5 milliseconds maximum (applicable to failure rate levels "M", "P", and "R").

Overload (high level only): Two times rated current. Not applicable to ac load ratings.

MIL-PRF-39016/18H

COIL DATA: See table I.

Operate time: 2.0 ms maximum over temperature range with rated coil voltage.
 Release time: 4.0 ms maximum over temperature range from rated coil voltage.

ELECTRICAL DATA:

Insulation resistance: 10,000 megohms minimum at 500 V dc, except the resistance between coil and case at high temperature shall be 1,000 megohms minimum.

Dielectric withstanding voltage:

	Sea level V rms (60 Hz)	Post intermediate current life test Sea level V rms (60 Hz)	Altitude V rms (60 Hz)
Between case, frame, or enclosure and all contacts in the energized and de-energized positions.	500	500	
Between case, frame, or enclosure and coils.	500	500	125
Between all contacts and coils.	500	500	All terminals to case
Between open contacts in the energized and de-energized positions.	500	375	
Between contact poles in the energized and de-energized positions.	500	500	
Between coils of dual coil relays.	N/A	N/A	

DIODE CHARACTERISTICS: 1/

Maximum negative transient: 1.0 volt.

Peak inverse voltage: 100 volts minimum.

Coil transient suppression: Applicable.

Semiconductor in-process screening: Applicable, visual inspection of semiconductors shall be in accordance with MIL-STD-750, method 2073 or 2074.

ENVIRONMENTAL DATA:

Temperature range: -65°C to +125°C.

Vibration (sinusoidal): MIL-STD-202, method 204. Contact chatter shall not exceed 10 microseconds maximum for closed contacts, and 1 microsecond maximum closure for open contacts.

Vibration (random): MIL-STD-202, method 214, test condition IG. Contact chatter shall not exceed 10 microseconds maximum for closed contacts, and 1 microsecond maximum closure for open contacts.
 Applicable to qualification and group C testing only.

Shock (specified pulse): MIL-STD-202, method 213, test condition B (75 g's). Contact chatter shall not exceed 10 microseconds maximum for closed contacts, and 1 microsecond maximum closure for open contacts.

1/ WARNING: Reverse polarity on coil terminals will destroy diode.

MIL-PRF-39016/18H

Magnetic interference: Applicable.

Resistance to soldering heat: Applicable.

Acceleration: Applicable.

Salt atmosphere (corrosion): In accordance with method 1041, MIL-STD-750.

PHYSICAL DATA:

Terminal strength (MIL-STD-202, method 211):

Pull test: Test condition A, 1 pound pull.

Bend test: Test condition C, ½ pound load.

Twist test: As specified in MIL-PRF-39016.

Solderability: Applicable.

Dimensions and configuration: See figures 1.

Weight: 2.55 grams (0.09 ounce) maximum.

Seal: Hermetic.

Minimum marking: Military part number, "J" with the date code (example J0430), circuit diagram, manufacturer's name or source code.

LIFE TEST REQUIREMENTS:

High level: 100,000 cycles per relay.

Low level: 100,000 cycles plus 900,000 cycles mechanical life.

Part or Identifying Number (PIN): M39016/18- (dash number from table I and suffix letter designating failure rate level).

TABLE I. Dash numbers and characteristics. 1/

Dash number 2/			Coil voltage 3/ (V dc)		At +25°C				Over temperature range		
Lead length .187 ±.010	Lead length .500 min	Spacer mounting pads (fig. 2) 4/	Rated	Max	Coil resistance ohms ±10%	Specified pickup value (voltage) (V dc)	Specified hold value (voltage) (V dc)	Specified dropout value (voltage) (V dc)	Specified pickup value (voltage) (V dc)	Specified hold value (voltage) (V dc)	Specified dropout value (voltage) (V dc)
025	031	037	5	5.8	50	2.7	1.4	0.22	3.5	2.3	0.14
026	032	038	6	8	98	3.5	2.0	0.28	4.5	3.2	0.18
027	033	039	9	12	220	5.3	3.0	0.54	6.8	4.9	0.35
028	034	040	12	16	390	7.0	4.0	0.63	9.0	6.5	0.41
029	035	041	18	24	880	10.5	6.0	0.91	13.5	10.0	0.59
030	036	042	26.5	32	1,560	14.2	8.0	1.37	18.0	13.0	0.89
	043 5/	049 5/	5	5.8	50	2.7	1.4	0.22	3.5	2.3	0.14
	044 5/	050 5/	6	8	98	3.5	2.0	0.28	4.5	3.2	0.18
	045 5/	051 5/	9	12	220	5.3	3.0	0.54	6.8	4.5	0.35
	046 5/	052 5/	12	16	390	7.0	4.0	0.63	9.0	6.5	0.41
	047 5/	053 5/	18	24	880	10.5	6.0	0.91	13.5	10.0	0.59
	048 5/	054 5/	26.5	32	1,560	14.2	8.0	1.37	18.0	13.0	0.89

- 1/ Each relay possesses high level and low level capabilities. However, relays previously tested or used above 10 mA resistive at 6 V dc maximum or peak ac open circuits not recommended for subsequent use in low level applications.
- 2/ The suffix letter L, M, P, or R to designate the applicable failure rate level shall be added to the applicable listed dash number. Failure rate level (percent per 10,000 cycles): L, 3.0; M, 1.0; P, 0.1; R, 0.01. Example, 031L - - - -54R.
- 3/ CAUTION: the use of any coil voltage less than the rated coil voltage will compromise the operation of the relay.
- 4/ Relays supplied with spacer mounting pads (-037 through -042 and -049 through -054) shall have the spacer mounting pad rigidly attached.
- 5/ Relays are supplied with a case grounding pin welded to the header (see figures 1 and 2).

QUALIFICATION INSPECTION:

Qualification inspection and sample size: See table II.

TABLE II. Qualification inspection and sample size. 1/

Single submission	Group submission	
18 units plus 1 open unit for level L at C = 0 2/	M39016/18-036	18 units plus 1 open unit for level L at C = 0 2/
33 units plus 1 open unit for level M at C = 0 2/		33 units plus 1 open unit for level M at C = 0 2/
Qualification inspection as applicable	M39016/18-031 M39016/18-032 M39016/18-033 M39016/18-034 M39016/18-035 M39016/18-048	Qualification inspection as applicable 2 units each PIN, qualification inspection, Q2. 1 unit terminal strength and solderability.

1/ For retention of qualification or extension of qualification to lower failure rate levels, all life test data accumulated on MIL-PRF-39016/19, /42, and /43, may be used in addition to MIL-PRF-39016/18 data. Prior to performance of retention of qualification testing, the relay manufacturer shall preselect the sampling plan.

2/ The number of units required for qualification testing shall be increased as required in Q5, MIL-PRF-39016, if the relay manufacturer elects to test the number of units permitting one or more failures. Prior to performance of qualification testing, the relay manufacturer shall preselect the sampling plan.

Qualification inspection (reduced testing) (sample size - 2 size each coil voltage and 1 unsealed unit). See table III.

If the relays produced for MIL-PRF-39016/18 are similar in construction and design except for the suppresser and steering diodes and coil assembly, as applicable, to the relays produced for MIL-PRF-39016/19, /42, and /43, then reduced testing for qualification of MIL-PRF-39016/18 relays may be performed concurrent with or subsequent to successful qualification of MIL-PRF-39016/19, /42, and /43 relays. For reduced testing, see table III.

TABLE III. Qualification inspection (reduced testing).

Examination or test
2 units each coil voltage
Q2 of qualification inspection table
1 unsealed sample unit for internal examination.

MIL-PRF-39016/18H

Initial qualification of relays supplied with spacer mounting pads (-037 through -042 and -049 through -054), shall be tested as specified below:

Perform the following tests as specified in the qualification inspection table of MIL-PRF-39016, in the order shown below:

Before installation of spacer mounting pad: Screening, visual and mechanical examination (internal), thermal shock, resistance to solvents, vibration (sinusoidal), vibration (random), shock (specified pulse), acceleration, terminal strength, magnetic interference (when specified), coil life (applicable to continuous duty relays only), resistance to soldering heat, salt spray (corrosion), overload (applicable to high level relays only), life, terminal strength, and intermediate current.

After installation of spacer mounting pad, perform the following tests as specified in the qualification inspection table of MIL-PRF-39016, in the order shown below:

Insulation resistance, dielectric withstanding voltage, static contact resistance, pickup voltage, hold voltage, dropout voltage, coil resistance, operate and release time, contact dynamic characteristics, coil transient suppression (when specified), solderability, seal, visual and mechanical inspection (external).

Qualification inspection (reduced testing for previously qualified relays) for relays supplied with spacer mounting pads (-037 through -042): Two units of the 26.5-volt rated coil voltage (-042) shall be tested as specified below:

Before installation of spacer mounting pad, perform the following tests as specified in the qualification inspection table of MIL-PRF-39016 in the order shown below:

For failure rate level L only: Screening.

For failure rate levels M, P, and R: Vibration (sinusoidal) test duration shall be 10 minutes, vibration (random), screening.

After installation of spacer mounting pad, perform the following tests as specified in the qualification inspection table of MIL-PRF-39016 in the order shown below:

Insulation resistance, dielectric withstanding voltage, static contact resistance, pickup voltage, hold voltage, and dropout voltage, coil resistance, operate and release time, contact dynamic characteristics, coil transient suppression (when specified), solderability, seal, visual and mechanical inspection (external).

Group A testing for relays supplied with spacer mounting pads (-037 through -042 and -049 through -054) shall be tested as specified below:

Perform seal test immediately preceding the A2 electrical tests. Relay leads shall be formed and the mounting pad removed before the seal test. After the seal test, the mounting pad shall be rigidly attached to the relay and the remaining group A tests performed (The seal test is not performed with group A4).

SUPERSESSION DATA:

Supersession data: See table IV.

MIL-PRF-39016/18H

TABLE IV. Supersession data. ^{1/}

Superseded part no. M39016/18-	New part no. M39016/18-	Superseded part no. M39016/18-	New part no. M39016/18-
001	031	013	031
002	032	014	032
003	033	015	033
004	034	016	034
005	035	017	035
006	036	018	036
007	025	019	025
008	026	020	026
009	027	021	027
010	028	022	028
011	029	023	029
012	030	024	030

^{1/} Dash numbers -001 through -024, .225 inch high cans have been canceled and are superseded by dash numbers -025 through -036, .280 inch high cans. The .225 inch cans are no longer manufactured.

Cross-reference for Government logistical support: See table V.

TABLE V. Cross reference for Government logistical support.

Superseded part no. M39016/18-	New part no. M39016/18-	Support with part no. M39016/	Superseded part no. M39016/18-	New part no. M39016/18-	Support with part no. M39016/	New part no. M39016/18-	Support with part no. M39016/
001	031	18-031	022	028	19-034	043	18-043
002	032	18-032	023	029	19-035	044	18-044
003	033	19-033	024	030	19-036	045	19-045
004	034	19-034		025	18-031	046	19-046
005	035	19-035		026	18-032	047	19-047
006	036	19-036		027	19-033	048	19-048
007	025	18-031		028	19-034	049	18-049
008	026	18-032		029	19-035	050	18-050
009	027	19-033		030	19-036	051	19-051
010	028	19-034		031	18-031	052	19-052
011	029	19-035		032	18-032	053	19-053
012	030	19-036		033	19-033	054	19-054
013	031	18-031		034	19-034		
014	032	18-032		035	19-035		
015	033	19-033		036	19-036		
016	034	19-034		037	18-037		
017	035	19-035		038	18-038		
018	036	19-036		039	19-039		
019	025	18-031		040	19-040		
020	026	18-032		041	19-041		
021	027	19-033		042	19-042		

Referenced documents. In addition to MIL-PRF-39016, this document references the following:

MIL-I-631
MIL-PRF-39016/19, /42, /43
MIL-STD-202
MIL-STD-750
MIL-STD-1285

Changes from previous issue: Marginal notations are not used in this revision to identify changes with respect to the previous issue due to the extent of the changes.

Custodians:
Army - CR
Navy - EC
Air Force - 11
DLA - CC

Preparing activity:
DLA - CC

Review activities:
Army - AR
Navy - AS, MC, OS, SH
Air Force - 99

(Project 5945-1284)

NOTE: The activities listed above were interested in this document as of the date of this document. Since organizations and responsibilities can change, you should verify the currency of the information above using the ASSIST Online database at <http://assist.daps.dla.mil>.