

Two-PLL Programmable Clock Generator for Portable Applications

Features

- Device Operating Voltage Options:
 - MoBL Clock M200 Family: 1.8 V
- Selectable clock output voltages for MoBL Clock M200:
 - 1.5 V, 1.8 V, 2.5 V, 3.0 V, or 3.3 V
- Fully integrated ultra low power phase-locked loops (PLLs)
- Input reference clock frequency range: 1–48 MHz
- Output clock frequency range: 3–50 MHz
- Three I²C™ programmable output clocks
- Programmable output drive strengths
- 150 ps typical cycle-to-cycle jitter
- Optional Spread Spectrum for EMI reduction
- 16-pin (3 × 3 × 0.6 mm) QFN Package
- Industrial temperature range

Benefits

- Suitable for cell phone, portable, and consumer electronics applications
- Multiple high-performance PLLs allow synthesis of unrelated frequencies
- Application compatibility in multiple output voltage levels
- Optional Spread Spectrum capable PLLs with Lexmark or Linear profile for maximum EMI reduction
- PLLs can be programmed for system frequency margin tests
- Meets critical timing requirements in complex system designs
- Individually enable or disable each output using I²C
- Ease of output clock selection using programmable crossbar switches

Logic Block Diagram

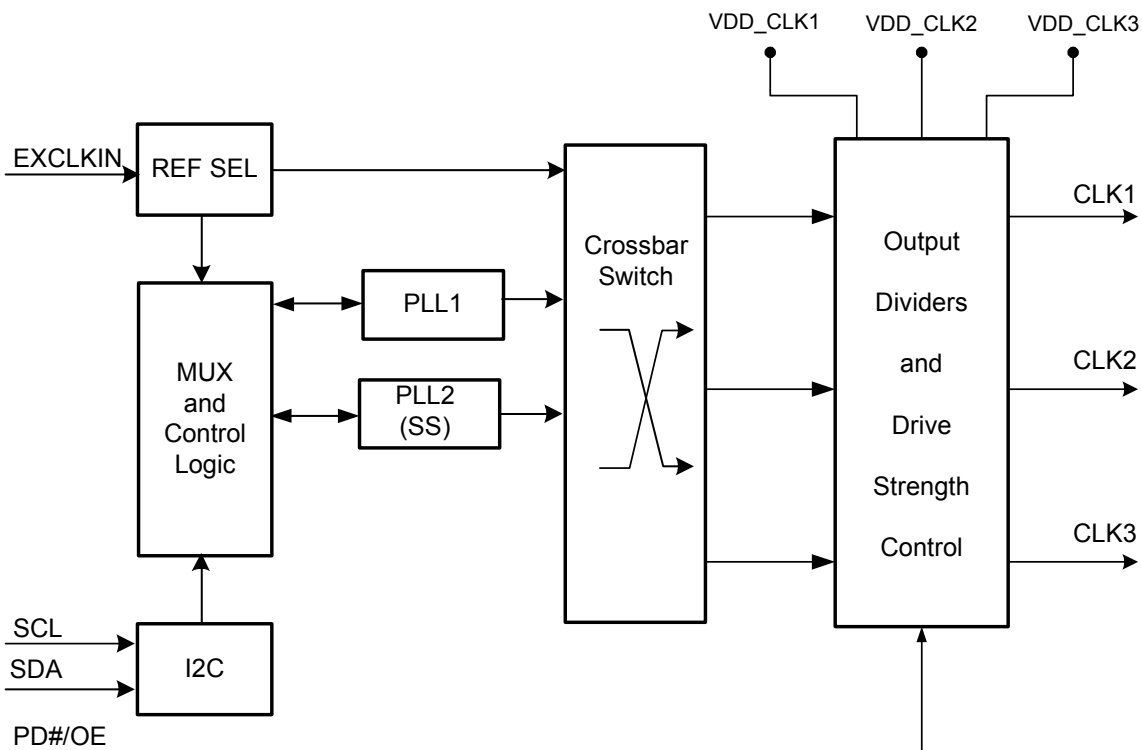

Contents

Pinouts	3	Random Read	5
MoBL Clock M200	3	Sequential Read	5
Pin Definitions	3	Serial Programming Interface Timing	7
General Description	4	Serial I2C Programming Interface	
2 Configurable PLLs	4	Timing Specifications	7
I2C Programming	4	Absolute Maximum Conditions	8
Input Reference Clocks	4	Recommended Operating Conditions	8
Output Power Supply Options	4	DC Electrical Specifications	9
Output Source Selection	4	AC Electrical Specifications	10
Spread Spectrum Control	4	Test and Measurement Setup	11
PD#/OE Mode	4	Voltage and Timing Definitions	11
Keep Alive Mode	4	Ordering Information	12
Output Drive Strength	4	Possible Configurations	12
Generic Configuration and Custom Frequency	4	Ordering Code Definitions	12
I2C Serial Interface	5	Package Drawing and Dimensions	13
Device Address	5	Acronyms	14
Data Valid	5	Document Conventions	14
Data Frame	5	Units of Measure	14
Acknowledge Pulse	5	Document History Page	15
Write Operations	5	Sales, Solutions, and Legal Information	16
Writing Individual Bytes	5	Worldwide Sales and Design Support	16
Writing Multiple Bytes	5	Products	16
Read Operations	5	PSoC Solutions	16
Current Address Read	5		

Pinouts

MoBL Clock M200

Figure 1. Pin Diagram – 16-pin QFN

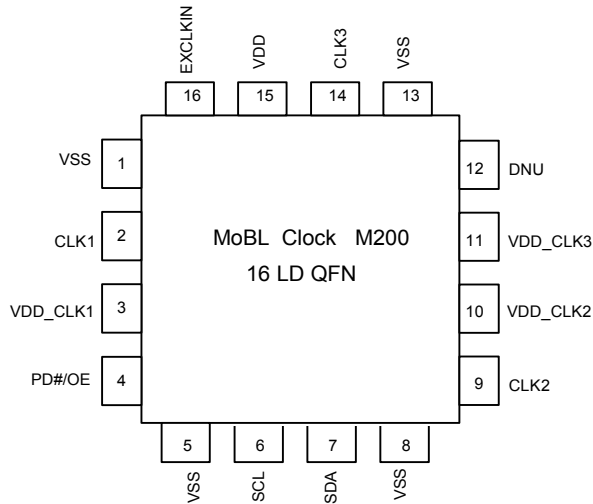

Pin Definitions

MoBL Clock M200 Family (VDD = 1.8 V Supply)

Pin Number	Name	IO	Description
1	VSS	Power	GND
2	CLK1	Output	Programmable Clock Output. Output voltage depends on VDD_CLK1 voltage
3	VDD_CLK1	Power	Power Supply for CLK1: 1.5 V/1.8 V/2.5 V/3.0 V/3.3 V
4	PD#/OE	Input	Multifunction Programmable pin: Output Enable or Power Down Modes
5	VSS	Power	GND
6	SCL	Input	I ² C-Bus Clock Line
7	SDA	Input/Output	I ² C-Bus Data Line
8	VSS	Power	GND
9	CLK2	Output	Programmable Clock Output. Output voltage depends on VDD_CLK2 voltage
10	VDD_CLK2	Power	Power Supply for CLK2: 1.5 V/1.8 V/2.5 V/3.0 V/3.3 V
11	VDD_CLK3	Power	Power Supply for output CLK3: 1.5 V/1.8 V/2.5 V/3.0 V/3.3 V
12	DNU	DNU	Do Not Use this pin
13	VSS	Power	GND
14	CLK3	Output	Programmable Clock Output. Output voltage depends on VDD_CLK3 voltage
15	VDD	Power	Power Supply: 1.8 V
16	EXCLKIN	Input	1.8 V external Reference Clock

General Description

2 Configurable PLLs

The MoBL[®] Clock M200 family of products are two-PLL clock generator ICs designed for cell phone, portable, or consumer electronics applications. It can be used to generate two independent output frequencies ranging from 3 to 50 MHz from a single input reference clock.

I²C Programming

The MoBL[®] Clock M200 have a serial I²C interface that programs the configuration memory array to synthesize output frequencies by programmable output divider, spread characteristics, and drive strength. I²C can also be used for in-system control of these programmable features.

Input Reference Clocks

The input to the M200 is designed to use an external reference clock with a frequency range of 1 MHz to 48 MHz at the EXCLKIN pin. The voltage level for the input reference clock used must follow VDD voltage used for the device as shown in the DC and AC specifications.

Output Power Supply Options

There are three clock outputs CLK1, CLK2, and CLK3 driven by three separate output power supplies: VDD_CLK1, VDD_CLK2, and VDD_CLK3 respectively. Different voltage level for each of these power supplies can be used and they can be any of 1.5 V, 1.8 V, 2.5 V, 3.0 V, or 3.3 V giving user multiple choice of output clock voltage levels.

Output Source Selection

These devices have three clock outputs, CLK1, CLK2 and CLK3. There are three available clock sources for these outputs. These clock sources are: PLL1, PLL2, or EXCLKIN. Output clock source selection is done using three out of three crossbar switch. Thus, any one of these three available clock sources can be arbitrarily selected for the clock outputs. This gives user a flexibility to have up to two independent clocks and a reference clock output.

Spread Spectrum Control

The PLL2 has spread spectrum capability for EMI reduction in the system. The device uses a Cypress proprietary PLL and Spread Spectrum Clock (SSC) technology to synthesize and modulate the frequency of the PLL. The spread spectrum feature can be turned on or off by I²C device programming. It can be factory programmed to either center spread range from $\pm 0.125\%$ to $\pm 2.50\%$, or down spread range from -0.25% to -5.0% , with Lexmark or Linear modulation profile.

PD#/OE Mode

PD#/OE input (Pin 4) can be programmed to operate as either power down (PD#) or output enable (OE) mode. Note that power down shuts off the entire chip, resulting in minimum power consumption for the device. Setting this signal high brings the device in the operational mode with default register settings. The PD# turn-on time is limited by the turn-on time of the PLLs. Disabled outputs are first driven to a low state before turning off. When off, they are held low by internal weak resistors (~160 kohms)

When this pin is programmed as Output Enable (OE), clock outputs can be enabled or disabled using OE (pin 4). Individual clock outputs can be programmed to be sensitive to this OE pin.

Keep Alive Mode

By activating the device in the Keep Alive Mode, power down mode is changed to power saving mode, which disables all PLLs and outputs, but preserves the contents of the volatile registers. Thus, any configuration changes made via the I²C interface are preserved. By deactivating the Keep Alive Mode, I²C memory is not preserved during power down, but power consumption is reduced relative to the Keep Alive Mode.

Output Drive Strength

The DC drive strength of the individual clock output can be programmed for different values. Table 1 shows the typical rise and fall times for different drive strength settings.

Table 1. Output Drive Strength

Output Drive Strength	Rise/Fall Time (ns) (Typical Value)
Low	6.8
Mid Low	3.4
Mid High	2.0
High	1.0

Generic Configuration and Custom Frequency

The device is available with Factory Specific programmed frequencies as shown in the Ordering Information page. This factory specific programmed part can be used for the device evaluation purposes. The MoBL[®] Clock can be custom programmed to any desired frequencies and listed features. For customer specific programming and I²C programmable memory bitmap definitions, please contact local Cypress Field Application Engineer (FAE) or sales representative.

I²C Serial Interface

To enhance the flexibility and function of the clock synthesizer, a two-signal I²C serial interface is provided. This interface is used to write (and optionally read) control registers that control various device functions such as enabling individual clock output buffers. The registers initialize to their default setting upon power up and therefore, use of this interface is optional. Clock device registers are normally changed upon system initialization. Any data written via I²C is volatile and is not retained when the device is powered down.

The I²C interface uses two signals, SDA and SCL, that operates up to 400 kbits/s in Read or Write mode. The SDA and SCL timing and data transfer sequence is shown in

Figure 2 on page 6. The basic Write serial format is as follows:

Start Bit; 7-bit Device Address (DA); R/W Bit; Slave Clock Acknowledge (ACK); 8-bit Memory Address (MA); ACK; 8-bit Data; ACK; 8-bit Data in MA+1 if desired; ACK; 8-bit Data in MA+2; ACK; etc. until STOP Bit. The basic serial format is illustrated in Figure 3 on page 6.

Device Address

The device serial interface address is 69H. The device address is combined with a read/write bit as the LSB and is sent after each start bit.

Data Valid

Data is valid when the clock is HIGH, and can only be transitioned when the clock is LOW, as illustrated in Figure 4 on page 6.

Data Frame

Every new data frame is indicated by a start and stop sequence, as illustrated in Figure 5 on page 7.

Start Sequence – SDA going LOW when SCL is HIGH indicates a Start Frame. Every time a start signal is supplied, the next 8-bit data must be the device address (seven bits) and a R/W bit, followed by register address (eight bits) and register data (eight bits).

Stop Sequence – SDA going HIGH when SCL is HIGH indicates a Stop Frame. A Stop Frame frees the bus to write to another part on the same bus or to write to another random register address.

Acknowledge Pulse

During Write Mode, the MoBL Clock M2xx responds with an Acknowledge pulse after every eight bits. This is done by pulling the SDA line LOW during the N⁹th clock cycle, as illustrated in Figure 6 on page 7 (N = the number of bytes transmitted). During Read Mode, the master generates the acknowledge pulse after reading the data packet.

Write Operations

Writing Individual Bytes

A valid write operation must have a full 8-bit register address after the device address word from the master, which is followed by an acknowledge bit from the slave (ack = 0/LOW). The next

eight bits must contain the data word intended for storage. After the receiving the data word, the slave responds with another acknowledge bit (ack = 0/LOW), and the master must end the write sequence with a STOP condition.

Writing Multiple Bytes

To write multiple bytes at a time, the master must not end the write sequence with a STOP condition, but instead sends multiple contiguous bytes of data to be stored. After each byte, the slave responds with an acknowledge bit, the same as after the first byte, and accepts data until the acknowledge bit is responded to by the STOP condition. When receiving multiple bytes, the MoBL Clock M2xx internally increments the register address.

Read Operations

Read operations are initiated the same way as Write operations except that the R/W bit of the slave address is set to '1' (HIGH). There are three basic read operations: current address read, random read, and sequential read.

Current Address Read

The MoBL Clock M2xx have an onboard address counter that retains '1' more than the address of the last word accessed. If the last word written or read was word 'n', then a current address read operation returns the value stored in location 'n+1'. When the MoBL Clock M2xx receives the slave address with the R/W bit set to a '1', it issues an acknowledge and transmits the 8-bit word. The master device does not acknowledge the transfer, but generates a STOP condition, which causes the MoBL Clock M2xx to stop transmission.

Random Read

Through random read operations, the master may access any memory location. To perform this type of read operation, first set the word address. To do this, send the address to the MoBL Clock M2xx as part of a write operation. After the word address is sent, the master generates a START condition following the acknowledge. This terminates the write operation before any data is stored in the address, but not before the internal address pointer is set. Next, the master reissues the control byte with the R/W byte set to '1'. The MoBL Clock M2xx then issues an acknowledge and transmits the 8-bit word. The master device does not acknowledge the transfer, but generates a STOP condition, which causes the MoBL Clock M200 to stop transmission.

Sequential Read

Sequential read operations follow the same process as random reads except that the master issues an acknowledge instead of a STOP condition after transmission of the first 8-bit data word. This action increments the internal address pointer, and subsequently outputs the next 8-bit data word. By continuing to issue acknowledges instead of STOP conditions, the master serially reads the entire contents of the slave device memory. When the internal address pointer points to the FFH register, after the next increment, the pointer points to the 00H register.

Figure 2. Data Transfer Sequence on the Serial Bus

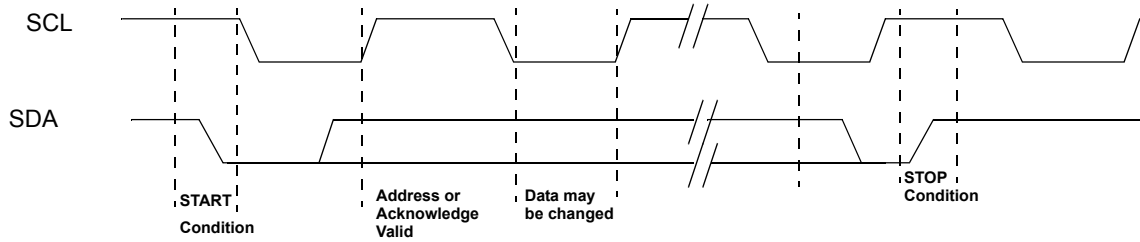

Figure 3. Data Frame Architecture

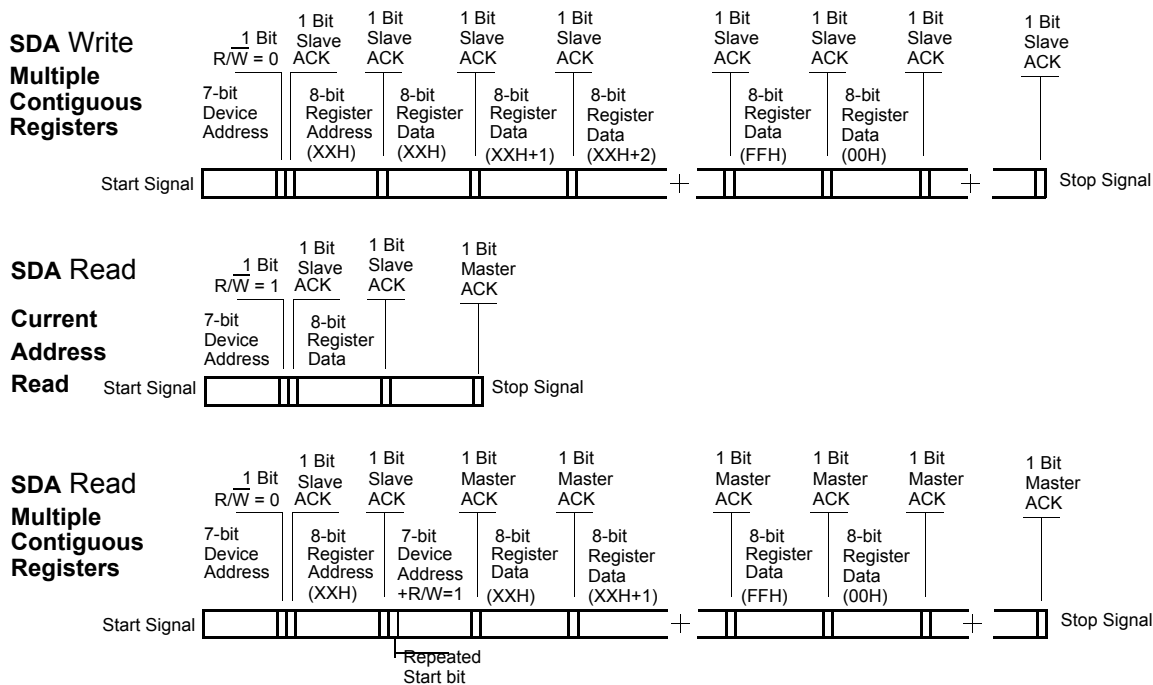
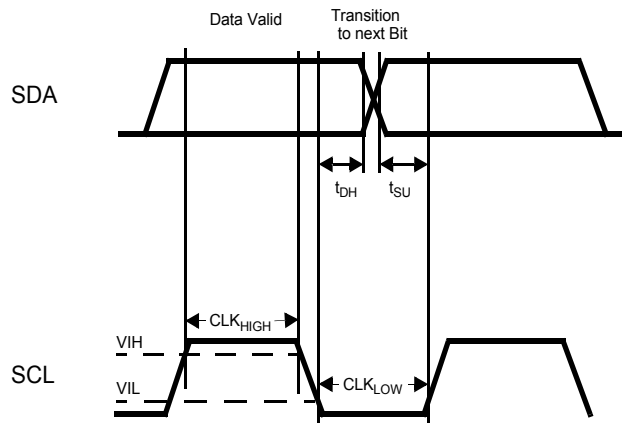

Figure 4. Data Valid and Data Transition Periods



Serial Programming Interface Timing

Figure 5. Start and Stop Frame

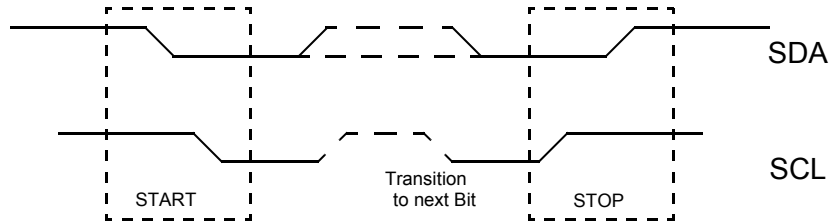
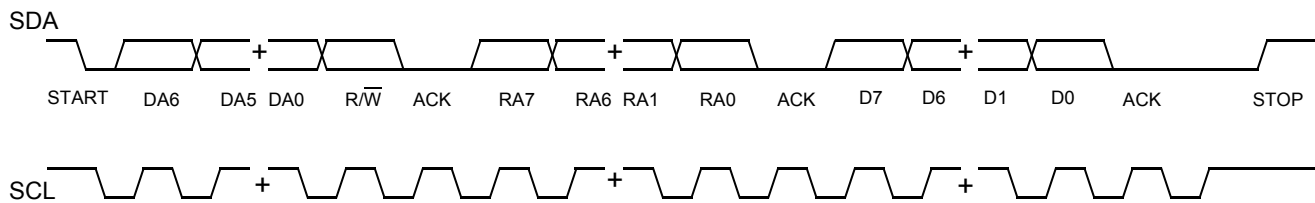

Figure 6. Frame Format (Device Address, $\overline{R/W}$, Register Address, Register Data)



Serial I²C Programming Interface Timing Specifications

Parameter	Description	Min	Max	Unit
f_{SCL}	Frequency of SCL	–	400	kHz
	Start Mode Time from SDA LOW to SCL LOW	0.6	–	μ s
CLK_{LOW}	SCL LOW Period	1.3	–	μ s
CLK_{HIGH}	SCL HIGH Period	0.6	–	μ s
t_{SU}	Data Transition to SCL HIGH	250	–	ns
t_{DH}	Data Hold (SCL LOW to data transition)	0	–	ns
	Rise Time of SCL and SDA	–	300	ns
	Fall Time of SCL and SDA	–	300	ns
	Stop Mode Time from SCL HIGH to SDA HIGH	0.6	–	μ s
	Stop Mode to Start Mode	1.3	–	μ s

Absolute Maximum Conditions

Parameter	Description	Condition	Min	Max	Unit
V _{DD}	Supply Voltage for MoBL Clock M2xx		-0.5	2.8	V
V _{DD_CLKX}	Supply Voltage for MoBL Clock M2xx		-0.5	4.4	V
V _{IN}	Input Voltage for MoBL Clock M2xx	Relative to V _{SS}	-0.5	2.2	V
T _S	Temperature, Storage	Non Functional	-65	+150	°C
ESD _{HBM}	ESD Protection (Human Body Model)	JEDEC EIA/JESD22-A114-E	2000	-	V
UL-94	Flammability Rating	V-0 @1/8 in.	-	10	ppm
MSL	Moisture Sensitivity Level		3		

Recommended Operating Conditions

The Recommended Operating Conditions table for MoBL Clock M2xx family.

Parameter	Description	Min	Typ	Max	Unit
V _{DD}	VDD Operating voltage for MoBL Clock M2xx	1.65	1.80	1.95	V
V _{DD_CLKX}	Output Driver Voltage for MoBL Clock M2xx	1.43	-	3.60	V
T _{AI}	Industrial Ambient Temperature	-40	-	85	°C
C _{LOAD}	Maximum Load Capacitance	-	-	15	pF
t _{PU}	Power up time for all V _{DD} s to reach minimum specified voltage (power ramps must be monotonic)	0.05	-	500	ms

DC Electrical Specifications

The DC Electrical Specification table for MoBL Clock M2xx family ($V_{DD_CLKX} = 1.5\text{ V}/1.8\text{ V}/2.5\text{ V}/3.0\text{ V}/3.3\text{ V}$).

Parameter	Description	Conditions	Min	Typ	Max	Unit
V _{OL}	Output Low Voltage	I _{OL} = 2 mA, drive strength = [00]	–	–	0.4	V
		I _{OL} = 3 mA, drive strength = [01]				
		I _{OL} = 7 mA, drive strength = [10]				
		I _{OL} = 12 mA, drive strength = [11]				
V _{OH}	Output High Voltage	I _{OH} = –2 mA, drive strength = [00]	V _{DD_CLKX} – 0.4	–	–	V
		I _{OH} = –3 mA, drive strength = [01]				
		I _{OH} = –7 mA, drive strength = [10]				
		I _{OH} = –12 mA, drive strength = [11]				
V _{OLSD}	Output Low Voltage, SDA	I _{OL} = 4 mA	–	–	0.4	V
V _{IL1}	Input Low Voltage of PD#/OE, SDA and SCL pins		–	–	0.2 × V _{DD}	V
V _{IL2}	Input Low Voltage of EXCLKIN pin		–	–	0.1 × V _{DD}	V
V _{IH1}	Input High Voltage of PD#/OE, SDA and SCL pins		0.8 × V _{DD}	–	–	V
V _{IH3}	Input High Voltage of EXCLKIN pin MoBL Clock M2xx		0.9 × V _{DD}	–	2.2	V
I _{IH}	Input High Current, PD#/OE	V _{IH} = V _{DD}	–	–	10	μA
I _{IL}	Input Low Current, PD#/OE	V _{IL} = 0 V	–	–	10	μA
R _{DN}	Pull Down Resistor of clocks (CLK1-CLK3) in off-state	Clock outputs in off-state by setting PD# = Low	100	160	250	kΩ
I _{DD} ^[1, 2]	Supply Current	All outputs running, C _{LOAD} = 0	–	15	–	mA
I _{DDS} ^[1]	Standby Current	PD# = Low, I ² C circuit not in Keep Alive Mode	–	3	–	μA
C _{IN} ^[2]	Input Capacitance	SCL, SDA, and PD#/OE inputs	–	–	7	pF

Notes

1. This parameter is configuration dependent. The specified value is for the drive level setting of [1,1].
2. Parameters are guaranteed by design and characterization. Not 100% tested in production. All parameters specified with fully loaded outputs.

AC Electrical Specifications

The AC Electrical Specifications table for M2xx ($V_{DD_CLKX} = 1.5\text{ V}/1.8\text{ V}/2.5\text{ V}/3.0\text{ V}/3.3\text{ V}$) family.

Parameter	Description	Conditions	Min	Typ	Max	Unit
F_{CLK}	Clock Output Frequency	All clock outputs	3	–	50	MHz
F_{REF}	Driven Reference Frequency	EXCLKIN Clock	1	–	48	MHz
DC	Output Clock Duty Cycle	Duty Cycle as defined in Figure 8 on page 11 t_1/t_2 , 50% of V_{DD_CLKX}	45	50	55	%
$T_{RF1}^{[4]}$	Output Clock Rise/Fall Time	Measured from 20% to 80% of V_{DD_CLKX} , as shown in Figure 9 on page 11 , $C_{LOAD} = 15\text{ pF}$, drive strength [00]	–	6.8	10.0	ns
$T_{RF2}^{[4]}$	Output Clock Rise/Fall Time	Measured from 20% to 80% of V_{DD_CLKX} , as shown in Figure 9 on page 11 , $C_{LOAD} = 15\text{ pF}$, drive strength [01]	–	3.4	5.0	ns
$T_{RF3}^{[4]}$	Output Clock Rise/Fall Time	Measured from 20% to 80% of V_{DD_CLKX} , as shown in Figure 9 on page 11 , $C_{LOAD} = 15\text{ pF}$, drive strength [10]	–	2.0	3.0	ns
$T_{RF4}^{[4]}$	Output Clock Rise/Fall Time	Measured from 20% to 80% of V_{DD_CLKX} , as shown in Figure 9 on page 11 , $C_{LOAD} = 15\text{ pF}$, drive strength [11]	–	1.0	1.5	ns
$T_{CCJ}^{[3, 4]}$	Cycle-to-cycle Jitter	EXCLKIN = CLKx = 48 MHz, $C_{LOAD} = 15\text{ pF}$, 2 PLLs and 1 output for each PLL enabled, drive strength = [11]	–	150	–	ps
$T_{LOCK}^{[4]}$	PLL Lock Time		–	1	3	ms

Notes

3. This parameter is configuration dependent. The specified value is for the drive level setting of [1,1].
4. Parameters are guaranteed by design and characterization. Not 100% tested in production. All parameters specified with fully loaded outputs.

Test and Measurement Setup

Figure 7. Test and Measurement Setup

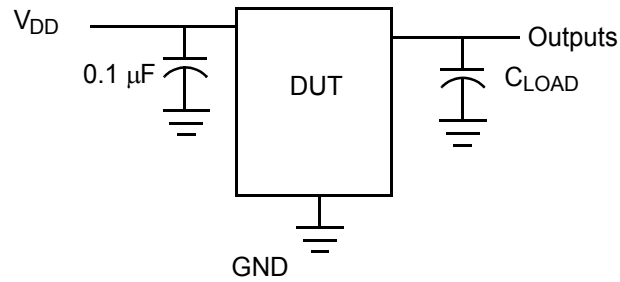

Voltage and Timing Definitions

Figure 8. Duty Cycle Definition

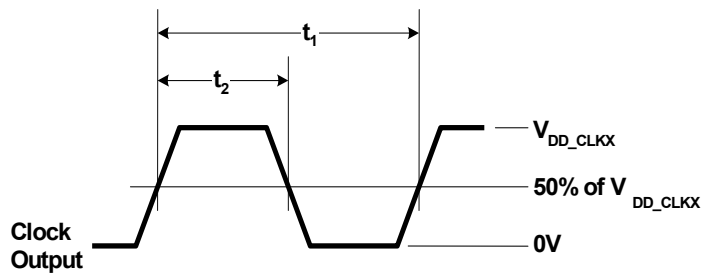
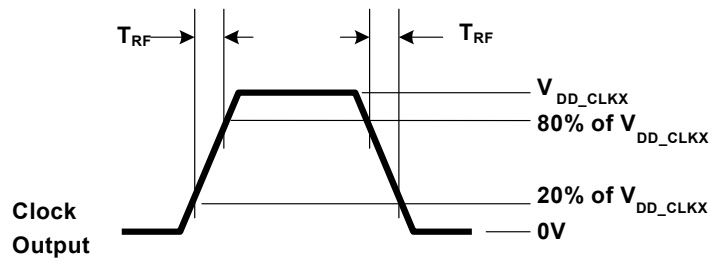

Figure 9. Rise Time = T_{RF} Fall Time = T_{RF}



Ordering Information

Part Number ^[5]	Frequency Configuration	Other Programmable Features	Package	Production Flow
Pb-Free				
M200LFXI	Factory Generic Configuration With EXCLKIN = 19.2 MHz CLK1 = 48.0 MHz CLK2 = 27.0 MHz	VDD = 1.8 V VDD_CLKx = 1.5 V/1.8 V/2.5 V/3.0 V/3.3 V Power Down = Enabled Keep Alive = Disabled Spread Spectrum = Disabled Output Drive Strength = [11]	16-pin QFN	Industrial, -40 °C to 85 °C
M200LFXIT	Factory Generic Configuration With EXCLKIN = 19.2 MHz CLK1 = 48.0 MHz CLK2 = 27.0 MHz	VDD = 1.8 V VDD_CLKx = 1.5 V/1.8 V/2.5 V/3.0 V/3.3 V Power Down = Enabled Keep Alive = Disabled Spread Spectrum = Disabled Output Drive Strength = [11]	16-pin QFN- Tape & Reel	Industrial, -40 °C to 85 °C

All product offerings are factory programmed customer specific devices with customized part numbers. The Possible Configurations table shows the available device types, but not complete part numbers. Contact your local Cypress FAE or Sales Representative for more information.

Possible Configurations

Part Number ^[5]	Frequency Configuration	Other Programmable Features	Package	Production Flow
M2xxLFXI	Customer Specific Configuration	VDD = 1.8 V VDD_CLKx = 1.5 V/1.8 V/2.5 V/3.0 V/3.3 V	16-pin QFN	Industrial, -40°C to 85°C
M2xxLFXIT	Customer Specific Configuration	VDD = 1.8 V VDD_CLKx = 1.5 V/1.8 V/2.5 V/3.0 V/3.3 V	16-pin QFN- Tape & Reel	Industrial, -40°C to 85°C

Ordering Code Definitions

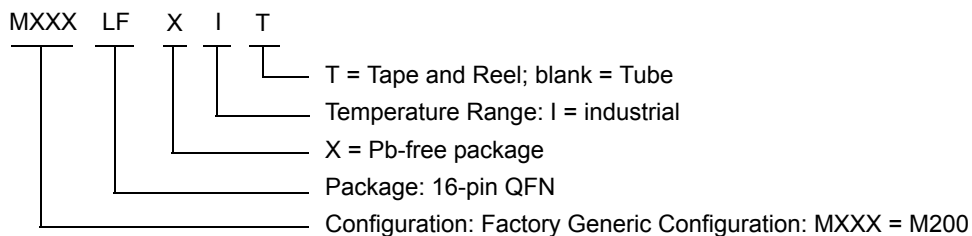

Note

5. xx indicates factory programmed parts based on customer specific configuration. For more details, contact your local Cypress FAE or Sales Representative

Acronyms

Acronym	Description
EMI	electromagnetic interference
FAE	field application engineer
OE	output enable
PLL	phase locked loop
QFN	quad flat no leads

Document Conventions

Units of Measure

Symbol	Unit of Measure
°C	degree Celsius
kΩ	kilo ohms
kHz	kilo Hertz
MHz	Mega Hertz
μA	micro Amperes
mA	milli Amperes
ms	milli seconds
mm	milli meter
ns	nano seconds
Ω	ohms
%	percent
pF	pico Farads
ppm	parts per million
ps	pico seconds
V	volts

Document History Page

Document Title: MoBL [®] Clock M200, Two-PLL Programmable Clock Generator for Portable Applications				
Document Number: 001-29139				
Rev.	ECN No.	Issue Date	Orig. of Change	Description of Change
**	1535744	See ECN	RGL / AESA	New Data Sheet
*A	2748211	08/10/09	TSAI	Posting to external web.
*B	2899297	03/25/10	CXQ	Moved 'xx' parts to Possible Configurations table. Updated Package Diagram
*C	3095377	11/25/2010	BASH	Added Ordering Code Definitions . Added Acronyms and Units of Measure . Minor edits and updated in new template.
*D	3847770	01/16/2013	AJU	Updated Ordering Information : Removed prune parts M500LFXI, M500LFXIT. Updated Package Drawing and Dimensions : spec 001-09116 – Changed revision from *E to *G. Removed M500 related information in all instances across the document.

Sales, Solutions, and Legal Information

Worldwide Sales and Design Support

Cypress maintains a worldwide network of offices, solution centers, manufacturer's representatives, and distributors. To find the office closest to you, visit us at [Cypress Locations](#).

Products

Automotive	cypress.com/go/automotive
Clocks & Buffers	cypress.com/go/clocks
Interface	cypress.com/go/interface
Lighting & Power Control	cypress.com/go/powerpsoc cypress.com/go/plc
Memory	cypress.com/go/memory
Optical & Image Sensing	cypress.com/go/image
PSoC	cypress.com/go/psoc
Touch Sensing	cypress.com/go/touch
USB Controllers	cypress.com/go/USB
Wireless/RF	cypress.com/go/wireless

PSoC Solutions

[psoc.cypress.com/solutions](#)
PSoC 1 | PSoC 3 | PSoC 5

© Cypress Semiconductor Corporation, 2007-2013. The information contained herein is subject to change without notice. Cypress Semiconductor Corporation assumes no responsibility for the use of any circuitry other than circuitry embodied in a Cypress product. Nor does it convey or imply any license under patent or other rights. Cypress products are not warranted nor intended to be used for medical, life support, life saving, critical control or safety applications, unless pursuant to an express written agreement with Cypress. Furthermore, Cypress does not authorize its products for use as critical components in life-support systems where a malfunction or failure may reasonably be expected to result in significant injury to the user. The inclusion of Cypress products in life-support systems application implies that the manufacturer assumes all risk of such use and in doing so indemnifies Cypress against all charges.

Any Source Code (software and/or firmware) is owned by Cypress Semiconductor Corporation (Cypress) and is protected by and subject to worldwide patent protection (United States and foreign), United States copyright laws and international treaty provisions. Cypress hereby grants to licensee a personal, non-exclusive, non-transferable license to copy, use, modify, create derivative works of, and compile the Cypress Source Code and derivative works for the sole purpose of creating custom software and or firmware in support of licensee product to be used only in conjunction with a Cypress integrated circuit as specified in the applicable agreement. Any reproduction, modification, translation, compilation, or representation of this Source Code except as specified above is prohibited without the express written permission of Cypress.

Disclaimer: CYPRESS MAKES NO WARRANTY OF ANY KIND, EXPRESS OR IMPLIED, WITH REGARD TO THIS MATERIAL, INCLUDING, BUT NOT LIMITED TO, THE IMPLIED WARRANTIES OF MERCHANTABILITY AND FITNESS FOR A PARTICULAR PURPOSE. Cypress reserves the right to make changes without further notice to the materials described herein. Cypress does not assume any liability arising out of the application or use of any product or circuit described herein. Cypress does not authorize its products for use as critical components in life-support systems where a malfunction or failure may reasonably be expected to result in significant injury to the user. The inclusion of Cypress' product in a life-support systems application implies that the manufacturer assumes all risk of such use and in doing so indemnifies Cypress against all charges.

Use may be limited by and subject to the applicable Cypress software license agreement.