

## Features

- Temperature ranges
  - Industrial: -40 °C to 85 °C
  - Automotive-A: -40 °C to 85 °C
  - Automotive-E: -40 °C to 125 °C
- Pin and function compatible with CY7C1011BV33
- High speed
  - $t_{AA} = 10$  ns (Industrial and Automotive-A)
  - $t_{AA} = 12$  ns (Automotive-E)
- Low active power
  - 360 mW (max) (Industrial and Automotive-A)
- 2.0 V data retention
- Automatic power down when deselected
- Independent control of upper and lower bits
- Easy memory expansion with Chip Enable ( $\overline{CE}$ ) and Output Enable ( $\overline{OE}$ ) features
- Available in Pb-free 44-pin thin small outline package (TSOP II), 44-pin thin quad flat package (TQFP), and non Pb-free 48-ball very fine-pitch ball grid array (VFBGA) packages

## Functional Description

The CY7C1011CV33 is a high performance complementary metal oxide semiconductor (CMOS) static RAM organized as 131,072 words by 16 bits. This device has an automatic power down feature that significantly reduces power consumption when deselected.

To write to the device, take  $\overline{CE}$  and Write Enable ( $\overline{WE}$ ) inputs LOW. If Byte Low Enable ( $\overline{BLE}$ ) is LOW, then data from I/O pins ( $I/O_0$  through  $I/O_7$ ), is written into the location specified on the address pins ( $A_0$  through  $A_{16}$ ). If Byte High Enable ( $\overline{BHE}$ ) is LOW, then data from I/O pins ( $I/O_8$  through  $I/O_{15}$ ) is written into the location specified on the address pins ( $A_0$  through  $A_{16}$ ).

To read from the device, take  $\overline{CE}$  and  $\overline{OE}$  LOW while forcing the Write Enable ( $\overline{WE}$ ) HIGH. If  $\overline{BLE}$  is LOW, then data from the memory location specified by the address pins appear on  $I/O_0$  to  $I/O_7$ . If Byte High Enable ( $\overline{BHE}$ ) is LOW, then data from memory appears on  $I/O_8$  to  $I/O_{15}$ . For more information, see the [Truth Table on page 10](#) for a complete description of Read and Write modes.

The input and output pins ( $I/O_0$  through  $I/O_{15}$ ) are placed in a high impedance state when the device is deselected ( $\overline{CE}$  HIGH), the outputs are disabled ( $\overline{OE}$  HIGH), the  $\overline{BHE}$  and  $\overline{BLE}$  are disabled ( $\overline{BHE}$ ,  $\overline{BLE}$  HIGH), or during a write operation ( $\overline{CE}$  LOW and  $\overline{WE}$  LOW).

## Logic Block Diagram

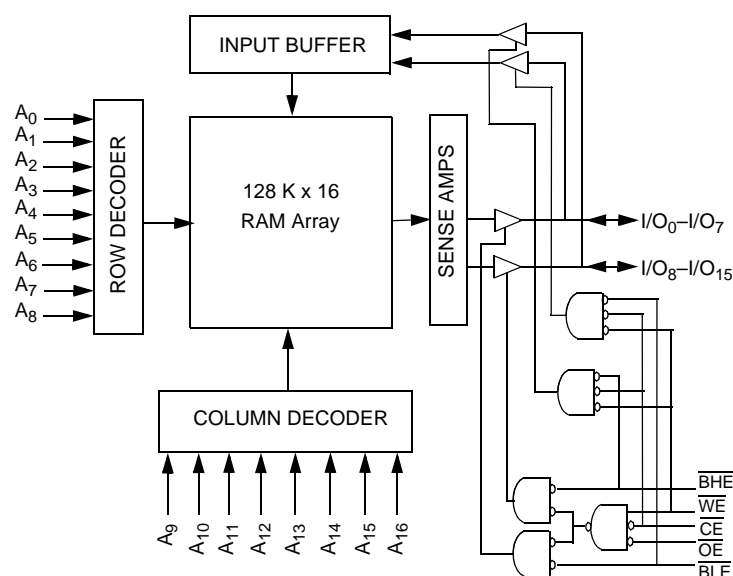

## Contents

<b>Pin Configuration</b> .....	<b>3</b>	<b>Ordering Information</b> .....	<b>11</b>
<b>Selection Guide</b> .....	<b>4</b>	Ordering Code Definitions .....	11
<b>Maximum Ratings</b> .....	<b>5</b>	<b>Package Diagrams</b> .....	<b>12</b>
<b>Operating Range</b> .....	<b>5</b>	<b>Acronyms</b> .....	<b>14</b>
<b>Electrical Characteristics</b> .....	<b>5</b>	<b>Document Conventions</b> .....	<b>14</b>
<b>Capacitance</b> .....	<b>6</b>	Units of Measure .....	14
<b>Thermal Resistance</b> .....	<b>6</b>	<b>Document History Page</b> .....	<b>15</b>
<b>AC Test Loads and Waveforms</b> .....	<b>6</b>	<b>Sales, Solutions, and Legal Information</b> .....	<b>16</b>
<b>Switching Characteristics</b> .....	<b>7</b>	Worldwide Sales and Design Support .....	16
<b>Switching Waveforms</b> .....	<b>8</b>	Products .....	16
<b>Truth Table</b> .....	<b>10</b>	PSoC Solutions .....	16

## Pin Configuration

Figure 1. 44-pin TSOP II <sup>[1]</sup>

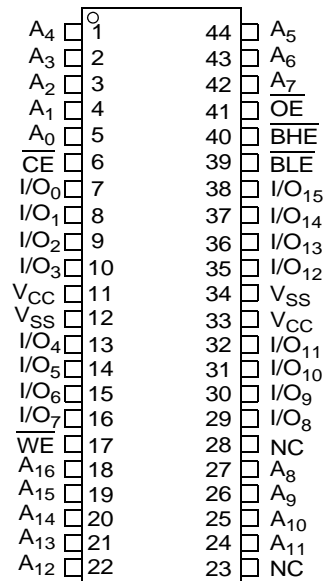
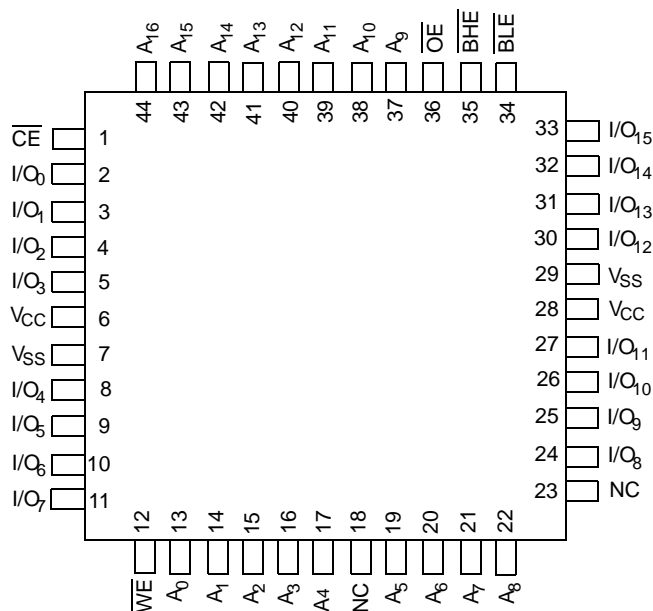

Figure 2. 44-pin TQFP



**Note**

1. NC pins are not connected on the die.

**Selection Guide**

Description		-10	-12	Unit
Maximum access time		10	12	ns
Maximum operating current	Industrial	100	95	mA
	Automotive-A	100	–	mA
	Automotive-E	–	120	mA
Maximum CMOS standby current	Industrial	10	10	mA
	Automotive-A	10	–	mA
	Automotive-E	–	15	mA

### Maximum Ratings

Exceeding maximum ratings may shorten the useful life of the device. These user guidelines are not tested.

- Storage temperature ..... -65 °C to +150 °C
- Ambient temperature with power applied ..... -55 °C to +125 °C
- Supply voltage on V<sub>CC</sub> relative to GND<sup>[2]</sup> ..... -0.5 V to +4.6 V
- DC voltage applied to outputs in High Z state<sup>[2]</sup> ..... -0.5 V to V<sub>CC</sub>+ 0.5 V
- DC input voltage<sup>[2]</sup> ..... -0.5 V to V<sub>CC</sub>+ 0.5 V

- Current into outputs (LOW) ..... 20 mA
- Static discharge voltage ..... > 2001 V (MIL-STD-883, method 3015)
- Latch up current ..... > 200 mA

### Operating Range

Range	Ambient Temperature (T <sub>A</sub> )	V <sub>CC</sub>
Industrial	-40 °C to +85 °C	3.3 V ± 10%
Automotive-A	-40 °C to +85 °C	
Automotive -E	-40 °C to +125 °C	

### Electrical Characteristics

Over the Operating Range

Parameter	Description	Test Conditions	-10		-12		Unit	
			Min	Max	Min	Max		
V <sub>OH</sub>	Output HIGH voltage	V <sub>CC</sub> = Min, I <sub>OH</sub> = -4.0 mA	2.4	-	2.4	-	V	
V <sub>OL</sub>	Output LOW voltage	V <sub>CC</sub> = Min, I <sub>OL</sub> = 8.0 mA	-	0.4	-	0.4	V	
V <sub>IH</sub>	Input HIGH voltage		2.0	V <sub>CC</sub> + 0.3	2.0	V <sub>CC</sub> + 0.3	V	
V <sub>IL</sub>	Input LOW voltage <sup>[2]</sup>		-0.3	0.8	-0.3	0.8	V	
I <sub>IX</sub>	Input leakage current	GND ≤ V <sub>I</sub> ≤ V <sub>CC</sub>	Industrial	-1	+1	-1	+1	μA
			Automotive-A	-1	+1	-	-	
			Automotive-E	-	-	-20	+20	
I <sub>OZ</sub>	Output leakage current	GND ≤ V <sub>I</sub> ≤ V <sub>CC</sub> , Output disabled	Industrial	-1	+1	-1	+1	μA
			Automotive-A	-1	+1	-	-	
			Automotive-E	-	-	-20	+20	
I <sub>CC</sub>	V <sub>CC</sub> operating supply current	V <sub>CC</sub> = Max, I <sub>OUT</sub> = 0 mA, f = f <sub>MAX</sub> = 1/t <sub>RC</sub>	Industrial	-	100	-	95	mA
			Automotive-A	-	100	-	-	
			Automotive-E	-	-	-	120	
I <sub>SB1</sub>	Automatic CE power down current — TTL Inputs	Max V <sub>CC</sub> , CE ≥ V <sub>IH</sub> , V <sub>IN</sub> ≥ V <sub>IH</sub> or V <sub>IN</sub> ≤ V <sub>IL</sub> , f = f <sub>MAX</sub>	Industrial	-	40	-	40	mA
			Automotive-A	-	40	-	-	
			Automotive-E	-	-	-	45	
I <sub>SB2</sub>	Automatic CE power down current — CMOS inputs	Max V <sub>CC</sub> , CE ≥ V <sub>CC</sub> - 0.3 V, V <sub>IN</sub> ≥ V <sub>CC</sub> - 0.3 V, or V <sub>IN</sub> ≤ 0.3 V, f = 0	Industrial	-	10	-	10	mA
			Automotive-A	-	10	-	-	
			Automotive-E	-	-	-	15	

**Note**

2. V<sub>IL</sub> (min) = -2.0 V for pulse durations of less than 20 ns.

### Capacitance

Parameter <sup>[3]</sup>	Description	Test Conditions	Max	Unit
C <sub>IN</sub>	Input capacitance	T <sub>A</sub> = 25 °C, f = 1 MHz, V <sub>CC</sub> = 3.3 V	8	pF
C <sub>OUT</sub>	Output capacitance		8	pF

### Thermal Resistance

Parameter <sup>[3]</sup>	Description	Test Conditions	44-pin TSOP II	44-pin TQFP	Unit
θ <sub>JA</sub>	Thermal resistance (Junction to ambient)	Still air, soldered on a 3 × 4.5 inch, four-layer printed circuit board	44.56	42.66	°C/W
θ <sub>JC</sub>	Thermal resistance (Junction to case)		10.75	14.64	°C/W

### AC Test Loads and Waveforms

Figure 3. AC Test Loads and Waveforms <sup>[4]</sup>

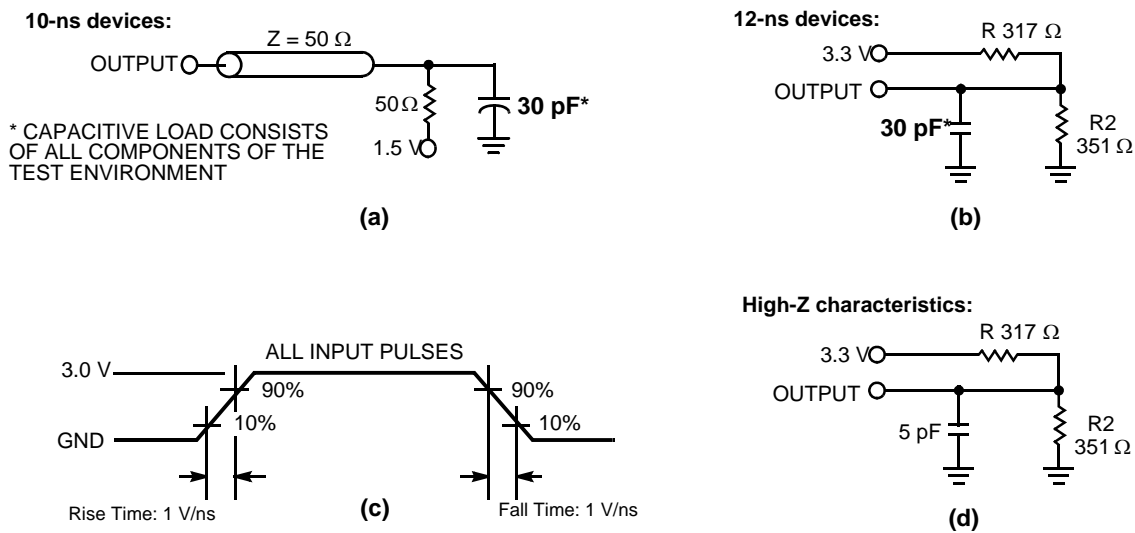

**Notes**

- 3. Tested initially and after any design or process changes that may affect these parameters.
- 4. AC characteristics (except High Z) for 10-ns parts are tested using the load conditions shown in Figure 3 (a). All other speeds are tested using the Thevenin load shown in Figure 3 (b). High Z characteristics are tested for all speeds using the test load shown in Figure 3 (d).

## Switching Characteristics

Over the Operating Range

Parameter <sup>[5]</sup>	Description	-10		-12		Unit
		Min	Max	Min	Max	
<b>Read Cycle</b>						
$t_{power}^{[6]}$	$V_{CC}$ (typical) to the first access	1	–	1	–	$\mu s$
$t_{RC}$	Read cycle time	10	–	12	–	ns
$t_{AA}$	Address to data valid	–	10	–	12	ns
$t_{OHA}$	Data hold from address change	3	–	3	–	ns
$t_{ACE}$	$\overline{CE}$ LOW to data valid	–	10	–	12	ns
$t_{DOE}$	$\overline{OE}$ LOW to data valid	Industrial/Automotive-A	–	5	–	6
		Automotive-E	–	–	–	8
$t_{LZOE}$	$\overline{OE}$ LOW to Low Z <sup>[7]</sup>	0	–	0	–	ns
$t_{HZOE}$	$\overline{OE}$ HIGH to High Z <sup>[7, 8]</sup>	–	5	–	6	ns
$t_{LZCE}$	$\overline{CE}$ LOW to Low Z <sup>[7]</sup>	3	–	3	–	ns
$t_{HZCE}$	$\overline{CE}$ HIGH to High Z <sup>[7, 8]</sup>	–	5	–	6	ns
$t_{PU}$	$\overline{CE}$ LOW to power up	0	–	0	–	ns
$t_{PD}$	$\overline{CE}$ HIGH to power down	–	10	–	12	ns
$t_{DBE}$	Byte enable to data valid	Industrial/Automotive-A	–	5	–	6
		Automotive-E	–	–	–	8
$t_{LZBE}$	Byte enable to Low Z	0	–	0	–	ns
$t_{HZBE}$	Byte disable to High Z	–	5	–	6	ns
<b>Write Cycle <sup>[9, 10]</sup></b>						
$t_{WC}$	Write cycle time	10	–	12	–	ns
$t_{SCE}$	$\overline{CE}$ LOW to write end	7	–	8	–	ns
$t_{AW}$	Address setup to write end	7	–	8	–	ns
$t_{HA}$	Address hold from write end	0	–	0	–	ns
$t_{SA}$	Address setup to write start	0	–	0	–	ns
$t_{PWE}$	$\overline{WE}$ pulse width	7	–	8	–	ns
$t_{SD}$	Data setup to write end	5	–	6	–	ns
$t_{HD}$	Data hold from write end	0	–	0	–	ns
$t_{LZWE}$	$\overline{WE}$ HIGH to Low Z <sup>[7]</sup>	3	–	3	–	ns
$t_{HZWE}$	$\overline{WE}$ LOW to High Z <sup>[7, 8]</sup>	–	5	–	6	ns
$t_{BW}$	Byte enable to end of write	7	–	8	–	ns

### Notes

- Test conditions assume signal transition time of 3 ns or less, timing reference levels of 1.5 V, and input pulse levels of 0 to 3.0 V.
- $t_{POWER}$  gives the minimum amount of time that the power supply is at typical  $V_{CC}$  values until the first memory access is performed.
- At any temperature and voltage condition,  $t_{HZCE}$  is less than  $t_{LZCE}$ ,  $t_{HZOE}$  is less than  $t_{LZOE}$ , and  $t_{HZWE}$  is less than  $t_{LZWE}$  for any device.
- $t_{HZOE}$ ,  $t_{HZBE}$ ,  $t_{HZCE}$ , and  $t_{HZWE}$  are specified with a load capacitance of 5 pF as in part (d) of [Figure 3 on page 6](#). Transition is measured  $\pm 500$  mV from steady state voltage.
- The internal write time of the memory is defined by the overlap of  $\overline{CE}$  LOW,  $\overline{WE}$  LOW, and  $\overline{BHE}/\overline{BLE}$  LOW.  $\overline{CE}$ ,  $\overline{WE}$ , and  $\overline{BHE}/\overline{BLE}$  must be LOW to initiate a write. The transition of these signals terminate the write. The input data setup and hold timing is referenced to the leading edge of the signal that terminates the write.
- The minimum write cycle time for Write Cycle No. 3 ( $\overline{WE}$  controlled,  $\overline{OE}$  LOW) is the sum of  $t_{HZWE}$  and  $t_{SD}$ .

### Switching Waveforms

Figure 4. Read Cycle No. 1 (Address Transition Controlled) [11, 12]

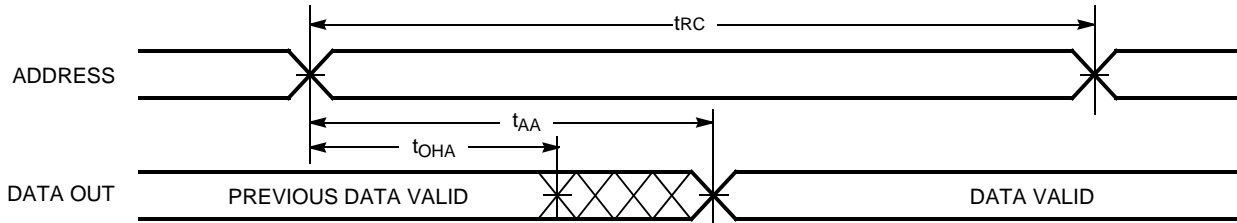
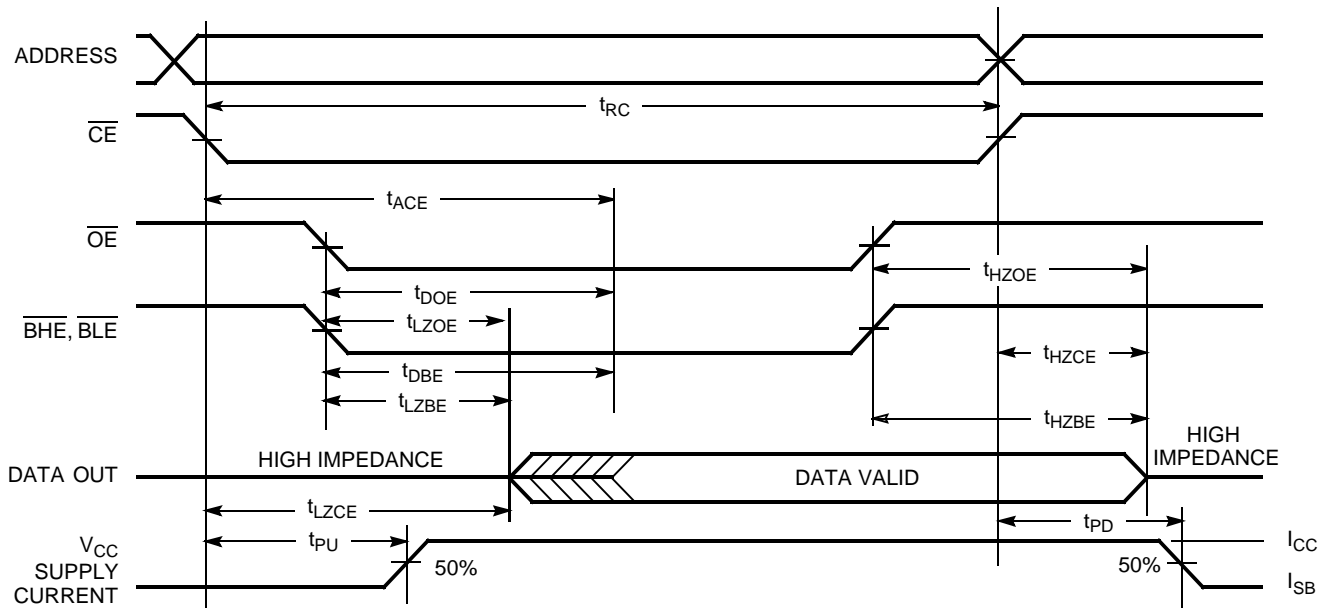

Figure 5. Read Cycle No. 2 ( $\overline{OE}$  Controlled) [12, 13]



**Notes**

- 11. Device is continuously selected.  $\overline{OE}$ ,  $\overline{CE}$ ,  $\overline{BHE}$ , and/or  $\overline{BLA}$  =  $V_{IL}$ .
- 12.  $\overline{WE}$  is HIGH for read cycle.
- 13. Address valid prior to or coincident with  $\overline{CE}$  transition LOW.



Switching Waveforms (continued)

Figure 6. Write Cycle No. 1 ( $\overline{\text{CE}}$  Controlled) [14, 15]

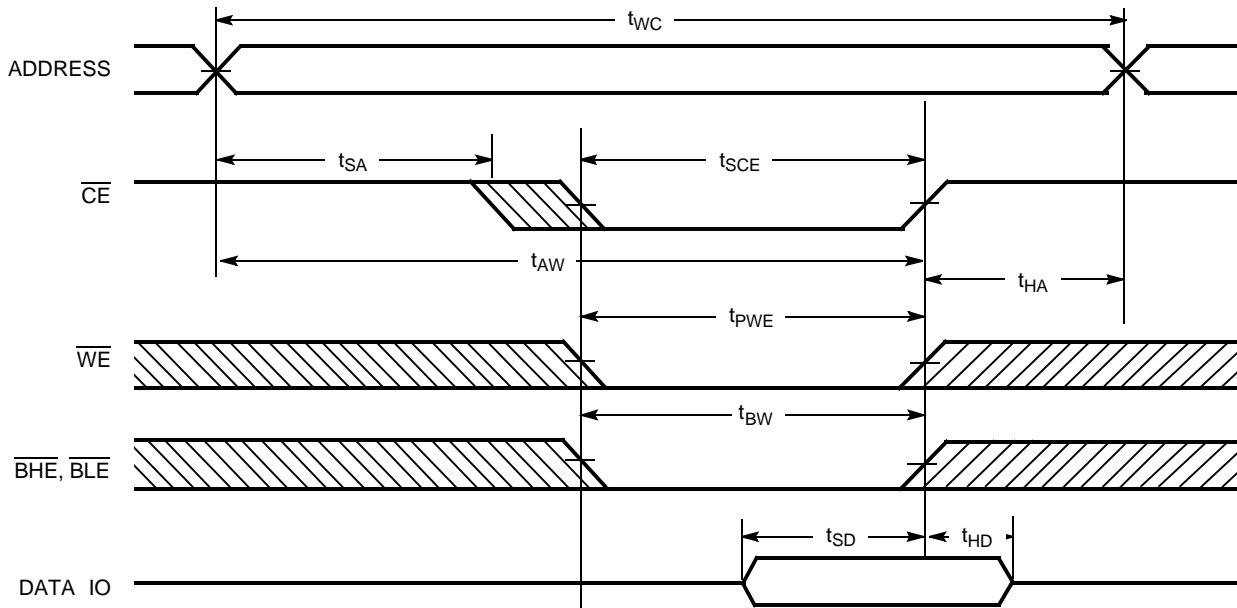
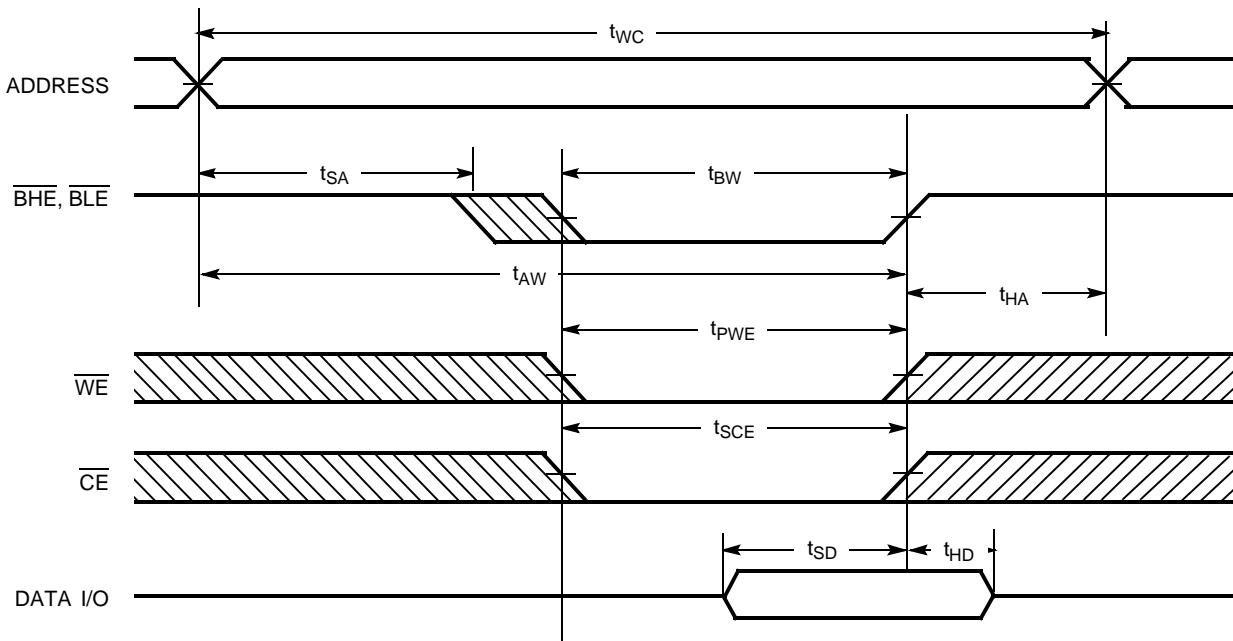

Figure 7. Write Cycle No. 2 ( $\overline{\text{BLE}}$  or  $\overline{\text{BHE}}$  Controlled)



Notes

- 14. Data I/O is high impedance if  $\overline{\text{OE}}$ ,  $\overline{\text{BHE}}$ , and/or  $\overline{\text{BLE}} = V_{IH}$ .
- 15. If  $\overline{\text{CE}}$  goes HIGH simultaneously with  $\overline{\text{WE}}$  going HIGH, the output remains in a high impedance state.

Switching Waveforms (continued)

Figure 8. Write Cycle No. 3 ( $\overline{WE}$  Controlled, LOW)

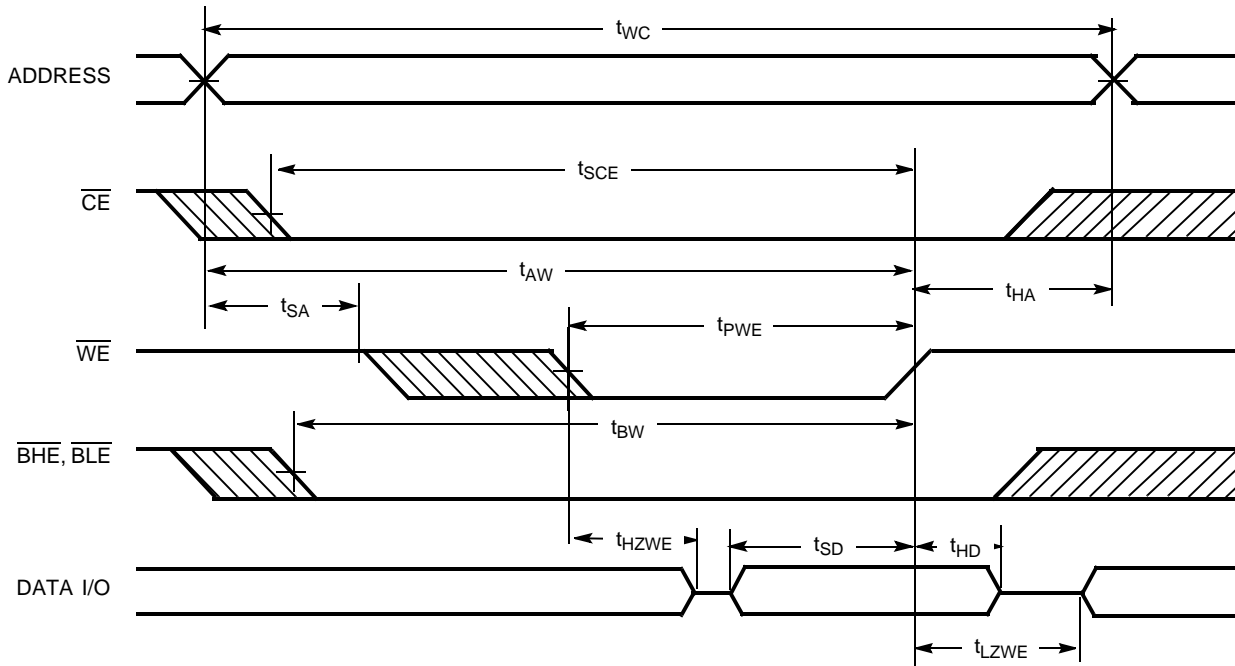

Truth Table

CE	OE	WE	BLE	BHE	I/O <sub>0</sub> -I/O <sub>7</sub>	I/O <sub>8</sub> -I/O <sub>15</sub>	Mode	Power
H	X	X	X	X	High Z	High Z	Power down	Standby ( $I_{SB}$ )
L	L	H	L	L	Data Out	Data Out	Read – all bits	Active ( $I_{CC}$ )
L	L	H	L	H	Data Out	High Z	Read – lower bits only	Active ( $I_{CC}$ )
L	L	H	H	L	High Z	Data Out	Read – upper bits only	Active ( $I_{CC}$ )
L	X	L	L	L	Data In	Data In	Write – all bits	Active ( $I_{CC}$ )
L	X	L	L	H	Data In	High Z	Write – lower bits only	Active ( $I_{CC}$ )
L	X	L	H	L	High Z	Data In	Write – upper bits only	Active ( $I_{CC}$ )
L	H	H	X	X	High Z	High Z	Selected, outputs disabled	Active ( $I_{CC}$ )

### Ordering Information

Speed (ns)	Ordering Code	Package Diagram	Package Type	Operating Range
10	CY7C1011CV33-10ZSXA	51-85087	44-pin TSOP II (Pb-free)	Automotive-A
12	CY7C1011CV33-12AXI	51-85064	44-pin TQFP (Pb-free)	Industrial
	CY7C1011CV33-12ZSXE	51-85087	44-pin TSOP II (Pb-free)	Automotive-E

### Ordering Code Definitions

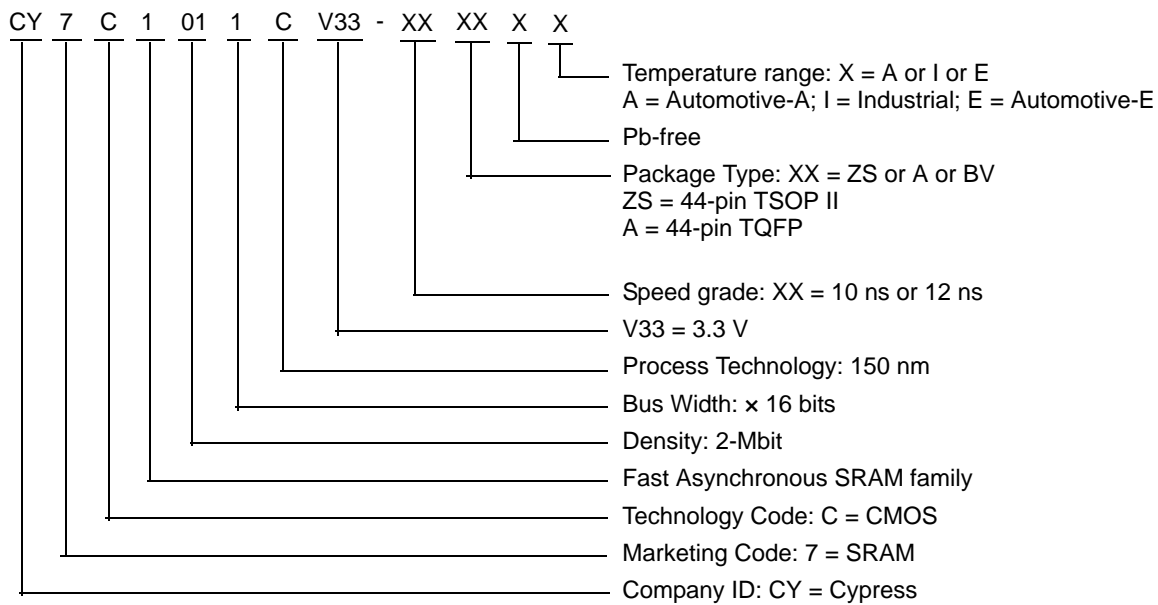

Package Diagrams

Figure 9. 44-pin TSOP Z44-II, 51-85087

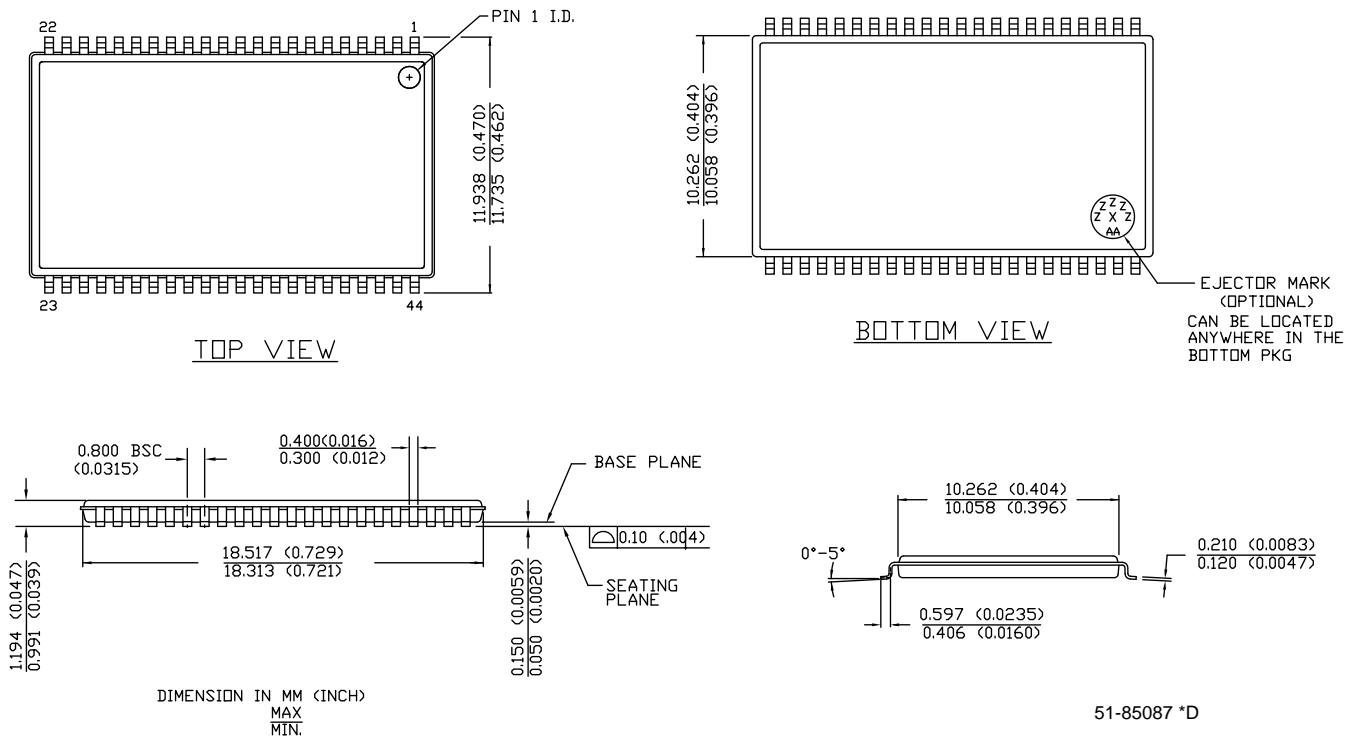

Package Diagrams (continued)

Figure 10. 44-pin TQFP (10 x 10 x 1.4 mm) A44S, 51-85064

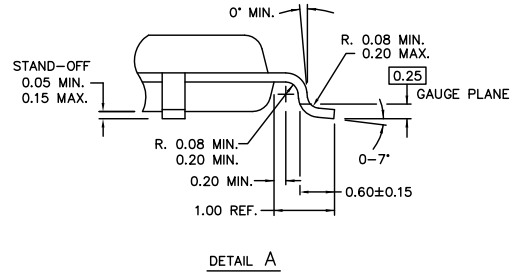
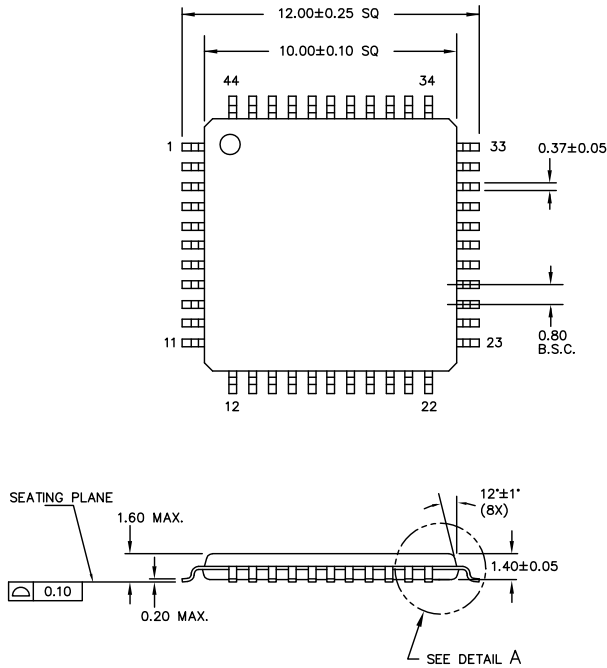

NOTE:

1. JEDEC STD REF MS-026
2. BODY LENGTH DIMENSION DOES NOT INCLUDE MOLD PROTRUSION/END FLASH  
MOLD PROTRUSION/END FLASH SHALL NOT EXCEED 0.0098 in (0.25 mm) PER SIDE  
BODY LENGTH DIMENSIONS ARE MAX PLASTIC BODY SIZE INCLUDING MOLD MISMATCH
3. DIMENSIONS IN MILLIMETERS

51-85064 \*E

### Acronyms

Acronym	Description
BHE	byte high enable
BLE	byte low enable
CMOS	complementary metal oxide semiconductor
CE	chip enable
I/O	input/output
OE	output enable
SRAM	static random access memory
TQFP	thin quad flat pack
TSOP	thin small outline package
TTL	transistor-transistor logic
VFBGA	very fine-pitch ball gird array
WE	write enable

### Document Conventions

#### Units of Measure

Symbol	Unit of Measure
°C	degree Celsius
MHz	megahertz
μA	microampere
μs	microsecond
mA	milliampere
mm	millimeter
ms	millisecond
mV	millivolt
mW	milliwatt
ns	nanosecond
%	percent
pF	pico farad
V	volt
W	watt

**Document History Page**

Document Title: CY7C1011CV33, 2-Mbit (128 K × 16) Static RAM				
Document Number: 38-05232				
Revision	ECN	Orig. of Change	Submission Date	Description of Change
**	117132	HGK	07/31/02	New Data Sheet
*A	118057	HGK	08/19/02	Pin configuration for 48-ball FBGA correction
*B	119702	DFP	10/11/02	Updated FBGA to VFBGA; updated package code on page 8 to BV48A. Updated address pinouts on page 1 to A0 to A16. Updated CMOS standby current on page 1 from 8 to 10 mA
*C	386106	PCI	See ECN	Added lead-free parts in Ordering Information Table
*D	498501	NXR	See ECN	Corrected typo in the Logic Block Diagram on page# 1 Included the Maximum Ratings for Static Discharge Voltage and Latch up Current on page# 3 Changed the description of I <sub>IX</sub> from Input Load Current to Input Leakage Current in DC Electrical Characteristics table Updated the Ordering Information Table
*E	522620	VKN	See ECN	Added Thermal Resistance Table
*F	1891366	VKN/AESA	See ECN	Added -10ZSXA part Updated Ordering Information table
*G	2428606	VKN/PYRS	See ECN	Corrected typo in the 44-Pin TSOP and 48-Ball FBGA pinout Removed Commercial parts Removed 15 ns speed bin Removed inactive parts from the Ordering Information table
*H	2664421	VKN/AESA	02/25/09	Added Automotive-E specs for 12 ns speed Updated Ordering Information table
*I	2898399	KAO/AJU	03/24/2010	Updated Package Diagrams
*J	2950666	VKN	06/11/2010	Included "CY7C1011CV33-12BVXE" in <a href="#">Ordering Information</a> Added <a href="#">Contents and Acronyms</a> Updated <a href="#">Sales, Solutions, and Legal Information</a> Added <a href="#">Ordering Code Definitions</a> .
*K	3089939	PRAS	11/13/2010	Removed inactive part from Ordering Information.
*L	3276463	KAO	06/07/2011	Updated <a href="#">Functional Description</a> (Removed "For best practice recommendations, refer to the Cypress application note AN1064, SRAM System Guidelines."). Added <a href="#">Units of Measure</a> . Updated <a href="#">Package Diagrams</a> . Updated in new template.
*M	3591978	TAVA	04/19/2012	Removed all information related to 48-ball VFBGA throughout the document. Updated package diagram revisions.

## Sales, Solutions, and Legal Information

### Worldwide Sales and Design Support

Cypress maintains a worldwide network of offices, solution centers, manufacturer's representatives, and distributors. To find the office closest to you, visit us at [Cypress Locations](#).

### Products

<a href="#">Automotive</a>	<a href="http://cypress.com/go/automotive">cypress.com/go/automotive</a>
<a href="#">Clocks &amp; Buffers</a>	<a href="http://cypress.com/go/clocks">cypress.com/go/clocks</a>
<a href="#">Interface</a>	<a href="http://cypress.com/go/interface">cypress.com/go/interface</a>
<a href="#">Lighting &amp; Power Control</a>	<a href="http://cypress.com/go/powerpsoc">cypress.com/go/powerpsoc</a> <a href="http://cypress.com/go/plc">cypress.com/go/plc</a>
<a href="#">Memory</a>	<a href="http://cypress.com/go/memory">cypress.com/go/memory</a>
<a href="#">Optical &amp; Image Sensing</a>	<a href="http://cypress.com/go/image">cypress.com/go/image</a>
<a href="#">PSoC</a>	<a href="http://cypress.com/go/psoc">cypress.com/go/psoc</a>
<a href="#">Touch Sensing</a>	<a href="http://cypress.com/go/touch">cypress.com/go/touch</a>
<a href="#">USB Controllers</a>	<a href="http://cypress.com/go/USB">cypress.com/go/USB</a>
<a href="#">Wireless/RF</a>	<a href="http://cypress.com/go/wireless">cypress.com/go/wireless</a>

### PSoC Solutions

[psoc.cypress.com/solutions](http://psoc.cypress.com/solutions)

[PSoC 1](#) | [PSoC 3](#) | [PSoC 5](#)

---

© Cypress Semiconductor Corporation, 2002-2012. The information contained herein is subject to change without notice. Cypress Semiconductor Corporation assumes no responsibility for the use of any circuitry other than circuitry embodied in a Cypress product. Nor does it convey or imply any license under patent or other rights. Cypress products are not warranted nor intended to be used for medical, life support, life saving, critical control or safety applications, unless pursuant to an express written agreement with Cypress. Furthermore, Cypress does not authorize its products for use as critical components in life-support systems where a malfunction or failure may reasonably be expected to result in significant injury to the user. The inclusion of Cypress products in life-support systems application implies that the manufacturer assumes all risk of such use and in doing so indemnifies Cypress against all charges.

Any Source Code (software and/or firmware) is owned by Cypress Semiconductor Corporation (Cypress) and is protected by and subject to worldwide patent protection (United States and foreign), United States copyright laws and international treaty provisions. Cypress hereby grants to licensee a personal, non-exclusive, non-transferable license to copy, use, modify, create derivative works of, and compile the Cypress Source Code and derivative works for the sole purpose of creating custom software and or firmware in support of licensee product to be used only in conjunction with a Cypress integrated circuit as specified in the applicable agreement. Any reproduction, modification, translation, compilation, or representation of this Source Code except as specified above is prohibited without the express written permission of Cypress.

Disclaimer: CYPRESS MAKES NO WARRANTY OF ANY KIND, EXPRESS OR IMPLIED, WITH REGARD TO THIS MATERIAL, INCLUDING, BUT NOT LIMITED TO, THE IMPLIED WARRANTIES OF MERCHANTABILITY AND FITNESS FOR A PARTICULAR PURPOSE. Cypress reserves the right to make changes without further notice to the materials described herein. Cypress does not assume any liability arising out of the application or use of any product or circuit described herein. Cypress does not authorize its products for use as critical components in life-support systems where a malfunction or failure may reasonably be expected to result in significant injury to the user. The inclusion of Cypress' product in a life-support systems application implies that the manufacturer assumes all risk of such use and in doing so indemnifies Cypress against all charges.

Use may be limited by and subject to the applicable Cypress software license agreement.