

Features

- High Speed
 - $t_{AA} = 15 \text{ ns}$
- Low Active Power
 - 440 mW (maximum 15 ns)
- Low CMOS Standby Power
 - 55 mW (maximum) 4 mW
- 2.0V Data Retention
- Automatic Power Down when deselected
- TTL-compatible Inputs and Outputs
- Easy Memory Expansion with \overline{CE}_1 , CE_2 , and \overline{OE} options

Functional Description

The CY7C109BN/CY7C1009BN^[1] is a high performance CMOS static RAM organized as 131,072 words by 8 bits. Easy memory expansion is provided by an active LOW Chip Enable (\overline{CE}_1), an active HIGH Chip Enable (CE_2), an active LOW Output Enable (\overline{OE}), and three-state drivers. Writing to the device is accomplished by taking Chip Enable One (\overline{CE}_1) and Write Enable (WE) inputs LOW and Chip Enable Two (CE_2) input HIGH. Data on the eight I/O pins (I/O_0 through I/O_7) is then written into the location specified on the address pins (A_0 through A_{16}).

Reading from the device is accomplished by taking Chip Enable One (\overline{CE}_1) and Output Enable (\overline{OE}) LOW while forcing Write Enable (WE) and Chip Enable Two (CE_2) HIGH. Under these conditions, the contents of the memory location specified by the address pins appear on the I/O pins.

The eight input/output pins (I/O_0 through I/O_7) are placed in a high impedance state when the device is deselected (\overline{CE}_1 HIGH or CE_2 LOW), the outputs are disabled (\overline{OE} HIGH), or during a write operation (\overline{CE}_1 LOW, CE_2 HIGH, and WE LOW).

The CY7C109BN is available in standard 400-mil-wide SOJ and 32-pin TSOP type I packages. The CY7C1009BN is available in a 300-mil-wide SOJ package. The CY7C1009BN and CY7C109BN are functionally equivalent in all other respects.

Logic Block Diagram

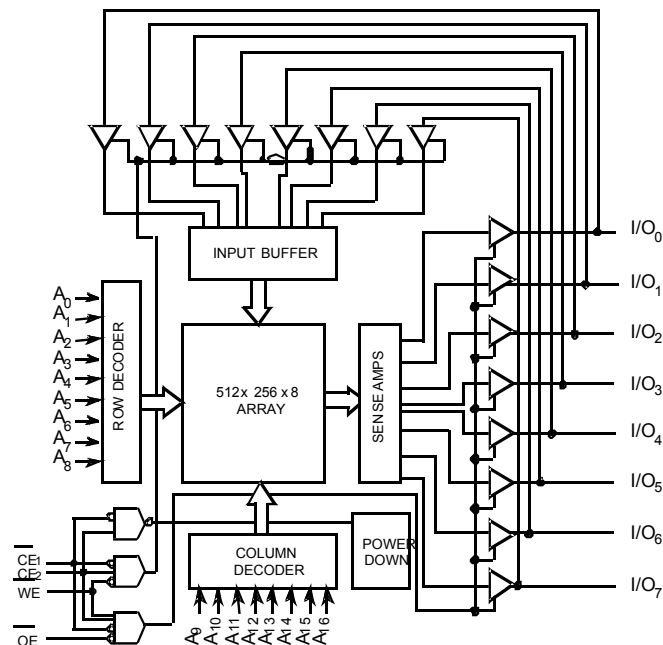

Note

1. For guidelines on SRAM system design, refer to the 'System Design Guidelines' Cypress application note, available on the internet at www.cypress.com.

Pin Configurations

Figure 1. 32-Pin SOJ (TopView)

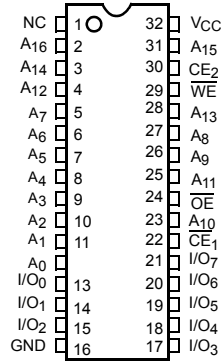

Selection Guide

Description	7C109B-15 7C1009B-15	7C109B-20 7C1009B-20	Unit
Maximum Access Time	15	20	ns
Maximum Operating Current	80	75	mA
Maximum CMOS Standby Current	10	10	mA
	L	2	mA

Maximum Ratings

Exceeding maximum ratings may shorten the useful life of the device. User guidelines are not tested.

- Storage Temperature -65°C to +150°C
- Ambient Temperature with Power Applied -55°C to +125°C
- Supply Voltage on V_{CC} to Relative GND^[2] -0.5V to +7.0V
- DC Voltage Applied to Outputs in High Z State^[2] -0.5V to V_{CC} + 0.5V
- DC Input Voltage^[2] -0.5V to V_{CC} + 0.5V

- Current into Outputs (LOW)..... 20 mA
- Static Discharge Voltage..... >2001V (per MIL-STD-883, Method 3015)
- Latch Up Current >200 mA

Operating Range

Range	Ambient Temperature	V _{CC}
Commercial	0°C to +70°C	5V ± 10%
Industrial	-40°C to +85°C	5V ± 10%

Electrical Characteristics Over the Operating Range

Parameter	Description	Test Conditions	7C109BN-15 7C1009BN-15		7C109BN-20 7C1009BN-20		Unit
			Min	Max	Min	Max	
V _{OH}	Output HIGH Voltage	V _{CC} = Min, I _{OH} = -4.0 mA	2.4		2.4		V
V _{OL}	Output LOW Voltage	V _{CC} = Min, I _{OL} = 8.0 mA		0.4		0.4	V
V _{IH}	Input HIGH Voltage		2.2	V _{CC} + 0.3	2.2	V _{CC} + 0.3	V
V _{IL}	Input LOW Voltage ^[2]		-0.3	0.8	-0.3	0.8	V
I _{IX}	Input Leakage Current	GND ≤ V _I ≤ V _{CC}	-1	+1	-1	+1	μA
I _{OZ}	Output Leakage Current	GND ≤ V _I ≤ V _{CC} , Output Disabled	-5	+5	-5	+5	μA
I _{OS}	Output Short Circuit Current ^[3]	V _{CC} = Max, V _{OUT} = GND		-300		-300	mA
I _{CC}	V _{CC} Operating Supply Current	V _{CC} = Max, I _{OUT} = 0 mA, f = f _{MAX} = 1/t _{RC}		80		75	mA
I _{SB1}	Automatic CE Power Down Current —TTL Inputs	Max V _{CC} , CE ₁ ≥ V _{IH} or CE ₂ ≤ V _{IL} , V _{IN} ≥ V _{IH} or V _{IN} ≤ V _{IL} , f = f _{MAX}		40		30	mA
I _{SB2}	Automatic CE Power Down Current —CMOS Inputs	Max V _{CC} , CE ₁ ≥ V _{CC} - 0.3V, or CE ₂ ≤ 0.3V, V _{IN} ≥ V _{CC} - 0.3V, or V _{IN} ≤ 0.3V, f = 0		10		10	mA
		L		2		2	mA

Capacitance

The following are the input and output capacitance test conditions.^[4]

Parameter	Description	Test Conditions	Max	Unit
C _{IN}	Input Capacitance	T _A = 25°C, f = 1 MHz, V _{CC} = 5.0V	9	pF
C _{OUT}	Output Capacitance		8	pF

Notes

2. Minimum voltage is -2.0V for pulse durations of less than 20 ns.
3. Not more than one output should be shorted at one time. Duration of the short circuit should not exceed 30 seconds.
4. Tested initially and after any design or process changes that may affect these parameters.

Figure 2. AC Test Loads and Waveforms

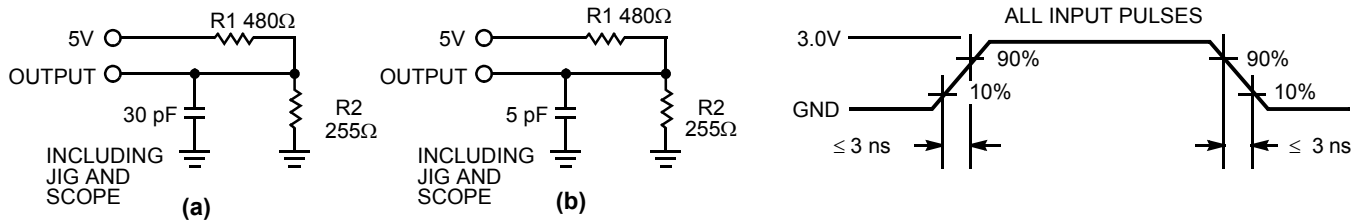

Equivalent to: THÉVENIN EQUIVALENT
 OUTPUT ○ — 167Ω — 1.73V ○

Switching Characteristics^[5] Over the Operating Range

Parameter	Description	7C109BN-15 7C1009BN-15		7C109BN-20 7C1009BN-20		Unit
		Min	Max	Min	Max	
Read Cycle						
t _{RC}	Read Cycle Time	15		20		ns
t _{AA}	Address to Data Valid		15		20	ns
t _{OHA}	Data Hold from Address Change	3		3		ns
t _{ACE}	CE ₁ LOW to Data Valid, CE ₂ HIGH to Data Valid		15		20	ns
t _{DOE}	OE LOW to Data Valid		7		8	ns
t _{LZOE}	OE LOW to Low Z	0		0		ns
t _{HZOE}	OE HIGH to High Z ^[6, 7]		7		8	ns
t _{LZCE}	CE ₁ LOW to Low Z, CE ₂ HIGH to Low Z ^[7]	3		3		ns
t _{HZCE}	CE ₁ HIGH to High Z, CE ₂ LOW to High Z ^[6, 7]		7		8	ns
t _{PU}	CE ₁ LOW to Power Up, CE ₂ HIGH to Power Up	0		0		ns
t _{PD}	CE ₁ HIGH to Power Down, CE ₂ LOW to Power Down		15		20	ns
Write Cycle^[8]						
t _{WC}	Write Cycle Time ^[9]	15		20		ns
t _{SCE}	CE ₁ LOW to Write End, CE ₂ HIGH to Write End	12		15		ns
t _{AW}	Address Setup to Write End	12		15		ns
t _{HA}	Address Hold from Write End	0		0		ns
t _{SA}	Address Setup to Write Start	0		0		ns
t _{PWE}	WE Pulse Width	12		12		ns
t _{SD}	Data Setup to Write End	8		10		ns
t _{HD}	Data Hold from Write End	0		0		ns
t _{LZWE}	WE HIGH to Low Z ^[7]	3		3		ns
t _{HZWE}	WE LOW to High Z ^[6, 7]		7		8	ns

Notes

- Test conditions assume signal transition time of 3 ns or less, timing reference levels of 1.5V, input pulse levels of 0 to 3.0V, and output loading of the specified I_{OL}/I_{OH} and 30-pF load capacitance.
- t_{HZOE}, t_{HZCE}, and t_{HZWE} are specified with a load capacitance of 5 pF as in part (b) of AC Test Loads. Transition is measured ±500 mV from steady-state voltage.
- At any given temperature and voltage condition, t_{HZCE} is less than t_{LZCE}, t_{HZOE} is less than t_{LZOE}, and t_{HZWE} is less than t_{LZWE} for any given device.
- The internal write time of the memory is defined by the overlap of CE₁ LOW, CE₂ HIGH, and WE LOW. CE₁ and WE must be LOW and CE₂ HIGH to initiate a write, and the transition of any of these signals can terminate the write. The input data setup and hold timing should be referenced to the leading edge of the signal that terminates the write.
- The minimum write cycle time for Write Cycle No. 3 (WE controlled, OE LOW) is the sum of t_{HZWE} and t_{SD}.

Data Retention Characteristics Over the Operating Range (Low Power version only)

Parameter	Description	Conditions	Min	Max	Unit
V_{DR}	V_{CC} for Data Retention	No input may exceed $V_{CC} + 0.5V$	2.0		V
I_{CCDR}	Data Retention Current	$V_{CC} = V_{DR} = 2.0V$, $CE_1 \geq V_{CC} - 0.3V$ or $CE_2 \leq 0.3V$,		150	μA
t_{CDR}	Chip Deselect to Data Retention Time	$V_{IN} \geq V_{CC} - 0.3V$ or $V_{IN} \leq 0.3V$	0		ns
t_R	Operation Recovery Time		200		μs

Figure 3. Data Retention Waveform

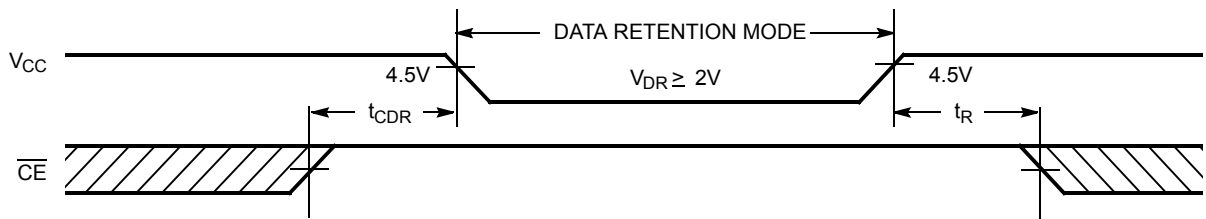

Switching Waveforms

Figure 4. Read Cycle No. 1^[10, 11]

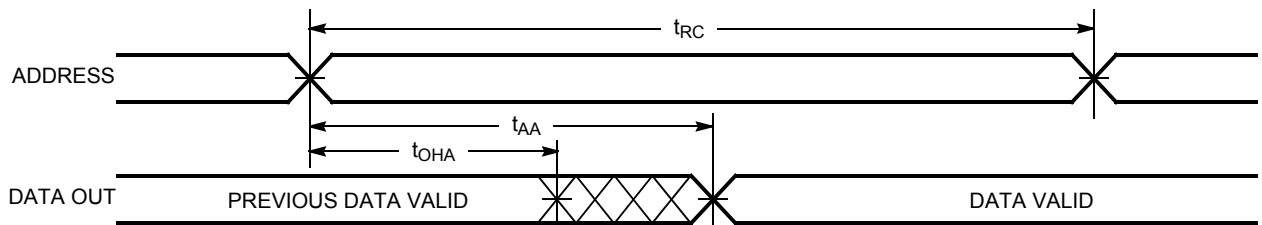
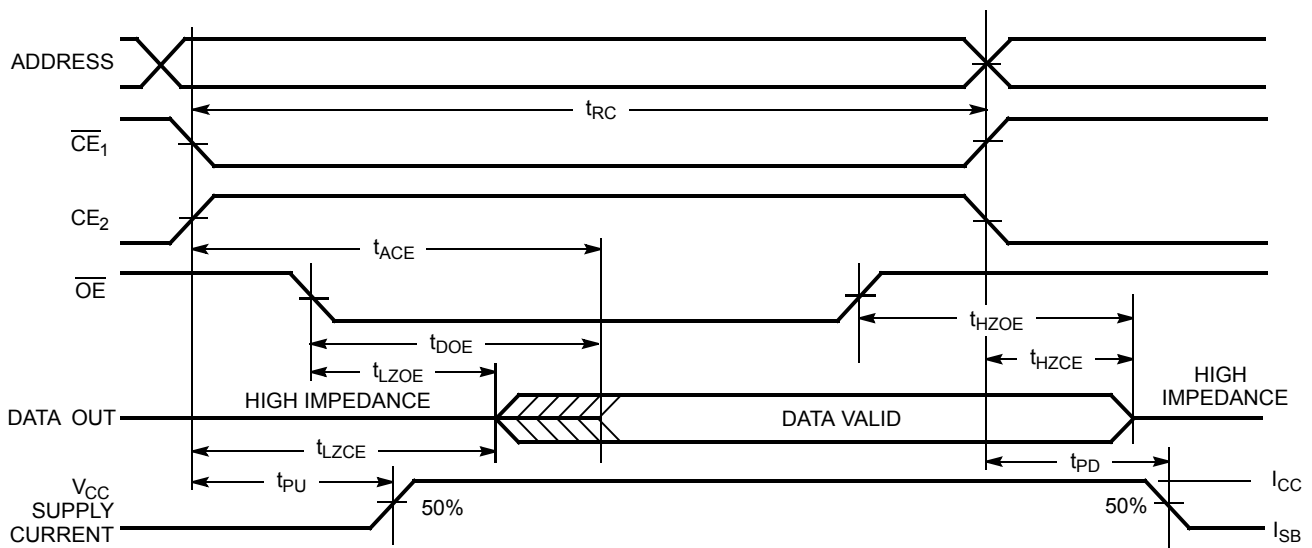

Figure 5. Read Cycle No. 2 (\overline{OE} Controlled)^[11, 12]



Notes

- 10. Device is continuously selected. \overline{OE} , $\overline{CE}_1 = V_{IL}$, $CE_2 = V_{IH}$.
- 11. WE is HIGH for read cycle.
- 12. Address valid prior to or coincident with \overline{CE}_1 transition LOW and CE_2 transition HIGH.

Switching Waveforms (continued)

Figure 6. Write Cycle No. 1 (\overline{CE}_1 or CE_2 Controlled)^[13, 14]

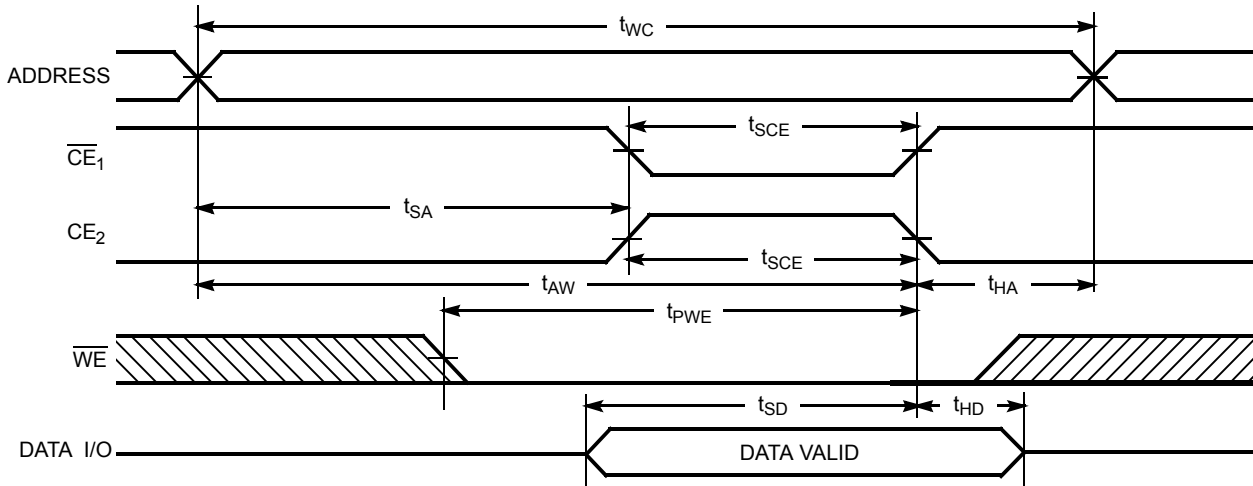
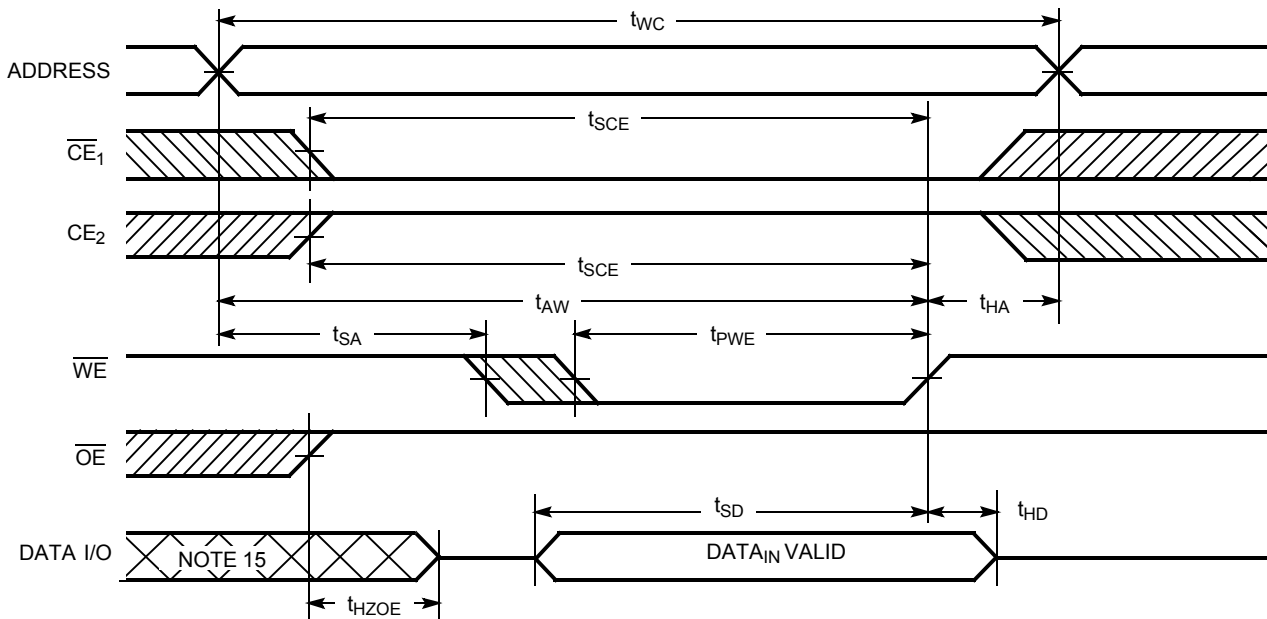

Figure 7. Write Cycle No. 2 (\overline{WE} Controlled, \overline{OE} HIGH During Write)^[13, 14]



Notes

- 13. Data I/O is high impedance if $\overline{OE} = V_{IH}$.
- 14. If \overline{CE}_1 goes HIGH or CE_2 goes LOW simultaneously with \overline{WE} going HIGH, the output remains in a high-impedance state.
- 15. During this period the I/Os are in the output state and input signals should not be applied.

Switching Waveforms (continued)

Figure 8. Write Cycle No. 3 (\overline{WE} Controlled, \overline{OE} LOW)^[14]

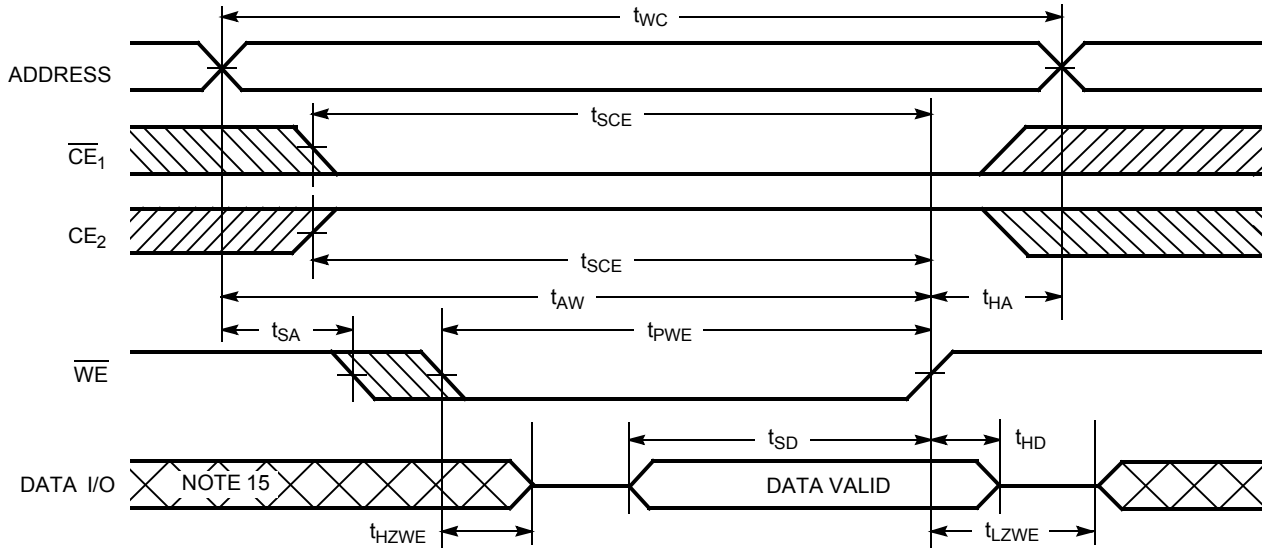

Truth Table

\overline{CE}_1	\overline{CE}_2	\overline{OE}	\overline{WE}	I/O ₀ -I/O ₇	Mode	Power
H	X	X	X	High Z	Power Down	Standby (I_{SB})
X	L	X	X	High Z	Power Down	Standby (I_{SB})
L	H	L	H	Data Out	Read	Active (I_{CC})
L	H	X	L	Data In	Write	Active (I_{CC})
L	H	H	H	High Z	Selected, Outputs Disabled	Active (I_{CC})

Ordering Information

Speed (ns)	Ordering Code	Package Diagram	Package Type	Operating Range
15	CY7C1009BN-15VI	51-85041	32-Pin (300-Mil) Molded SOJ	Industrial
20	CY7C109BN-20VI	51-85033	32-Pin (400-Mil) Molded SOJ	Industrial

Contact your local sales representative regarding availability of these parts

Package Diagrams

Figure 9. 32-Pin (300-Mil) Molded

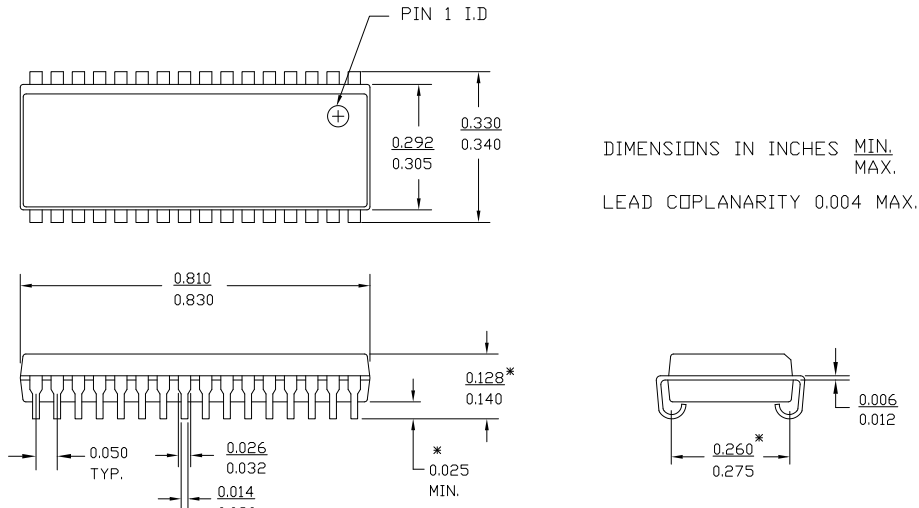

51-85041 *B

Figure 10. 32-Pin (400-Mil) Molded SOJ

32 Lead (400 MIL) Molded SOJ V33

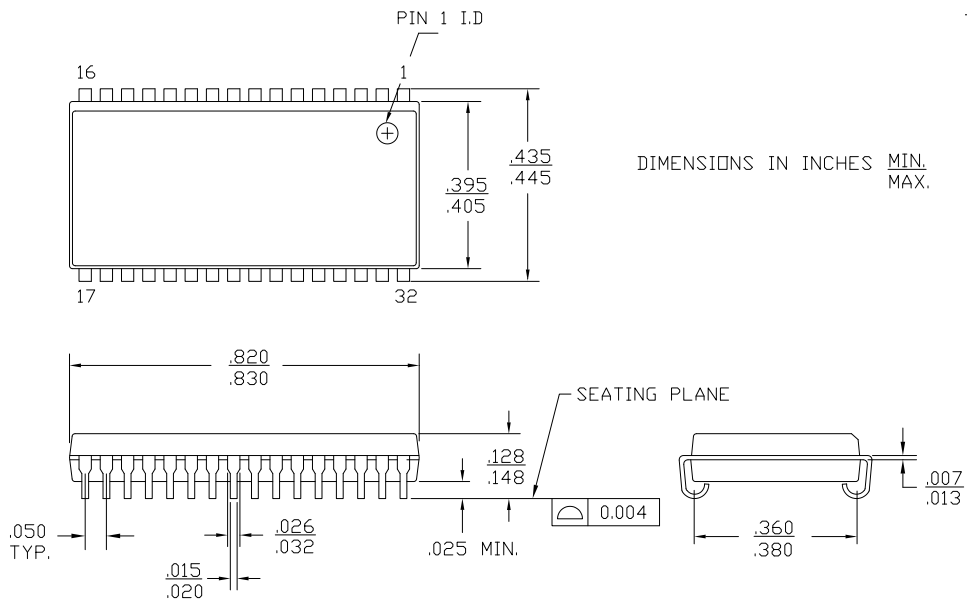

51-85033 *C

Document History Page

Document Title: CY7C109BN/CY7C1009BN 128K x 8 Static RAM Document Number: 001-06430				
REV.	ECN No.	Orig. of Change	Submission Date	Description of Change
**	423847	NXR	See ECN	New Data Sheet
*A	2755340	NXR	08/24/2009	Removed -12 from product offering as 12ns parts are not active Corrected Package Diagram Updated ordering Information
*B	2904565	AJU	04/05/10	Removed inactive part number from the ordering information table.Updated package diagrams.

Sales, Solutions, and Legal Information

Worldwide Sales and Design Support

Cypress maintains a worldwide network of offices, solution centers, manufacturer’s representatives, and distributors. To find the office closest to you, visit us at cypress.com/sales.

Products

- PSoC psoc.cypress.com
- Clocks & Buffers clocks.cypress.com
- Wireless wireless.cypress.com
- Memories memory.cypress.com
- Image Sensors image.cypress.com

© Cypress Semiconductor Corporation, 2006-2010. The information contained herein is subject to change without notice. Cypress Semiconductor Corporation assumes no responsibility for the use of any circuitry other than circuitry embodied in a Cypress product. Nor does it convey or imply any license under patent or other rights. Cypress products are not warranted nor intended to be used for medical, life support, life saving, critical control or safety applications, unless pursuant to an express written agreement with Cypress. Furthermore, Cypress does not authorize its products for use as critical components in life-support systems where a malfunction or failure may reasonably be expected to result in significant injury to the user. The inclusion of Cypress products in life-support systems application implies that the manufacturer assumes all risk of such use and in doing so indemnifies Cypress against all charges.

Any Source Code (software and/or firmware) is owned by Cypress Semiconductor Corporation (Cypress) and is protected by and subject to worldwide patent protection (United States and foreign), United States copyright laws and international treaty provisions. Cypress hereby grants to licensee a personal, non-exclusive, non-transferable license to copy, use, modify, create derivative works of, and compile the Cypress Source Code and derivative works for the sole purpose of creating custom software and or firmware in support of licensee product to be used only in conjunction with a Cypress integrated circuit as specified in the applicable agreement. Any reproduction, modification, translation, compilation, or representation of this Source Code except as specified above is prohibited without the express written permission of Cypress.

Disclaimer: CYPRESS MAKES NO WARRANTY OF ANY KIND, EXPRESS OR IMPLIED, WITH REGARD TO THIS MATERIAL, INCLUDING, BUT NOT LIMITED TO, THE IMPLIED WARRANTIES OF MERCHANTABILITY AND FITNESS FOR A PARTICULAR PURPOSE. Cypress reserves the right to make changes without further notice to the materials described herein. Cypress does not assume any liability arising out of the application or use of any product or circuit described herein. Cypress does not authorize its products for use as critical components in life-support systems where a malfunction or failure may reasonably be expected to result in significant injury to the user. The inclusion of Cypress’ product in a life-support systems application implies that the manufacturer assumes all risk of such use and in doing so indemnifies Cypress against all charges.

Use may be limited by and subject to the applicable Cypress software license agreement.