

Low RMS Phase Jitter Programmable LVDS Clock Generator

Features

- Programmable LVDS clock generator
- Low RMS Phase Jitter
- Available output frequencies: 50 MHz to 700 MHz
- Package: Pb-free 8-pin thin shrunk small outline package (TSSOP)
- Supply voltage: 3.3 V or 2.5 V
- Temperature: Industrial

Functional Description

The CY2XL12 is a phase locked loop (PLL)-based high-performance clock generator that uses Cypress's low-noise voltage control oscillator (VCO) technology to achieve less than 1 ps typical RMS phase jitter. The CY2XL12 uses an external crystal reference input and drives one LVDS output pair having programmable drive strength. CY2XL12 can be programmed as Output Enable (OE), or Power Down (PD#), or Frequency Select (FS) device by configuring the pin 5. The device can be programmed either to operate at 3.3 V or at 2.5 V.

Logic Block Diagram

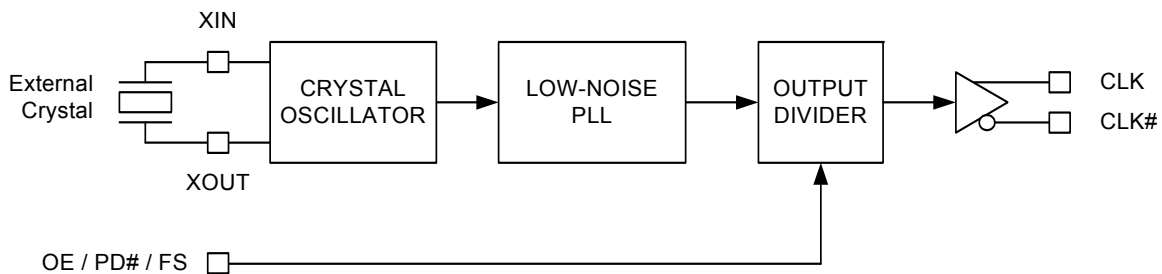

Contents

Pinouts	3	Switching Waveforms	11
Pin Definitions	3	Ordering Information	13
Frequency Table	3	Ordering Code Definitions	13
Functional Overview	3	Package Drawing and Dimensions	14
Application Information	4	Acronyms	15
Power Supply Filtering Techniques	4	Document Conventions	15
Board Layout and OE Pin	4	Units of Measure	15
Termination for LVDS Output	4	Document History Page	16
Crystal Interface	4	Sales, Solutions, and Legal Information	17
Termination Circuits	5	Worldwide Sales and Design Support	17
Phase Jitter	6	Products	17
Absolute Maximum Conditions	8	PSoC@Solutions	17
Operating Conditions	8	Cypress Developer Community	17
DC Electrical Characteristics	9	Technical Support	17
AC Electrical Characteristics	10		
Crystal Characteristics	10		

Pinouts

Figure 1. 8-pin TSSOP pinout

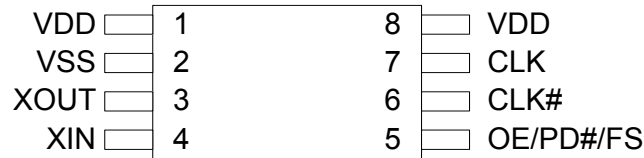

Pin Definitions

Pin Number	Pin Name	I/O Type	Description
1, 8	VDD	Power	3.3 V or 2.5 V power supply. All supply current flows through pin 1
2	VSS	Power	Ground
3, 4	XOUT, XIN	XTAL output and input	Parallel resonant crystal interface
5	OE / PD# / FS	CMOS input	Output enable pin: Active HIGH. If OE=1, CLK is enabled. When LOW, the output is high impedance Power-down pin: Active LOW. If PD# = 0, the device is powered down and the clock is disabled. Frequency Select pin: One of the two stored frequencies can be selected.
6, 7	CLK#, CLK	LVDS output	Differential clock output; drives one or two LVDS loads

Frequency Table

Part Number	Crystal Frequency	Output Frequency	Drive Strength	Pin 5 Function	RMS Phase Jitter (Random)	
					Offset Range	Jitter (Typical)
CY2XL12ZXI01	25 MHz	108 MHz	High	OE	637 kHz to 10 MHz	0.55 ps
CY2XL12ZXI02	25 MHz	100 MHz	High	OE	637 kHz to 10 MHz	0.53 ps
CY2XL12ZXI03	25 MHz	150 MHz	High	OE	637 kHz to 10 MHz	0.48 ps
CY2XL12ZXI06	25 MHz	50 MHz	Normal	PD#	12 kHz to 20 MHz	1.0 ps

Functional Overview

The CY2XL12 device with external crystal option has OE or PD# or FS feature of Pin 5. The OE function is used to enable or

disable CLK output. PD# function can quickly put the device in low-power state, but it takes longer time to wake-up because of reacquire of PLL lock. FS feature is used to select two different output frequencies for multirate serializer application.

Application Information

Power Supply Filtering Techniques

As in any high-speed analog circuitry, noise at the power-supply pins can degrade performance. To achieve optimum jitter performance, use good power-supply isolation practices. Figure 2 illustrates a typical filtering scheme. Because all the current flows through pin 1, the resistance and inductance between this pin and the supply is minimized. A 0.01 or 0.1 μF ceramic chip capacitor is also located close to this pin to provide a short and low-impedance AC path to ground. A 1 to 10 μF ceramic or tantalum capacitor is located in the general vicinity of this device and may be shared with other devices.

Figure 2. Power Supply Filtering

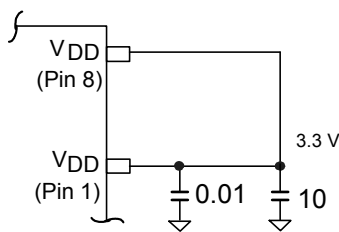

Board Layout and OE Pin

If the Output Enable (OE) function on pin 5 is not needed, it may be connected directly to the V_{DD} plane by a wide trace and multiple vias. This improves heat dissipation. A resistor between OE and V_{DD} is not necessary.

Termination for LVDS Output

The CY2XL12 is designed with programmable output drive-strength. When it is configured with High-drive, it can drive two standard LVDS loads, each one with a 100 Ω termination resistor. Figure 5 on page 5 shows the standard termination scheme. When it is programmed for Normal-drive, it can drive only one standard LVDS load (100 Ω termination resistor) as

shown in Figure 6. The termination resistors should always be located very close to the receivers, and the trace branches should be located close to the CY2XL12 output. To minimize signal reflections from the receivers, the differential impedance (Z_0) of each trace pair should be 100 Ω to match the termination resistor.

Crystal Interface

CY2XL12 should have minimum 8 pF load capacitor parallel to the resonant crystal. The capacitors C1 and C2 as shown in Figure 3 are chosen to minimize the ppm error. These optimum values of C1 and C2 can be derived based on the parasitic trace capacitance (C_p), and capacitance of the CY2XL12 device pins (XIN and XOUT). Values of C1 and C2 are layout dependant and can be calculated as $C1 = C2 = 2 \times (CL - C_p)$. When the drive level of the crystal is low and the drive level of CY2XL12 is high, the application may need an additional resistor R_{out} . When R_{out} is added, C2 is also required to be readjusted for the precise frequency calculation.

Figure 3. Crystal Input Interface

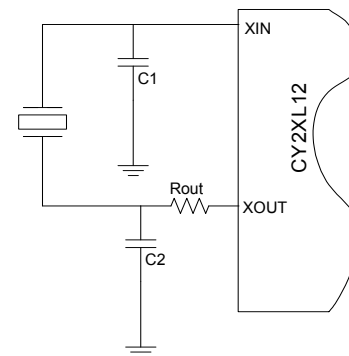

Termination Circuits

Figure 4. Test Load

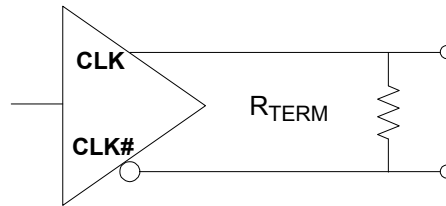

Figure 5. Application Load (High drive strength device)

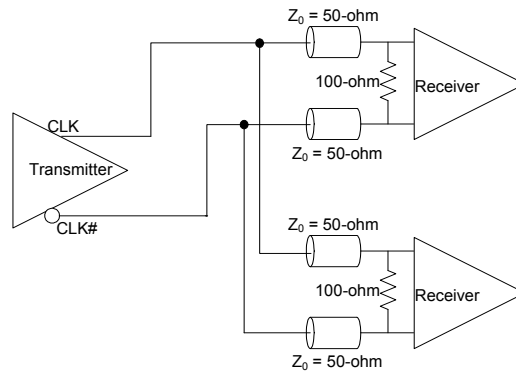
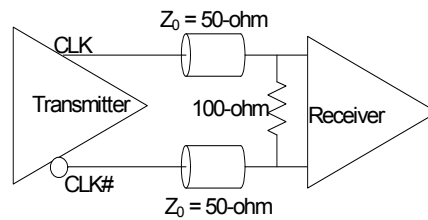
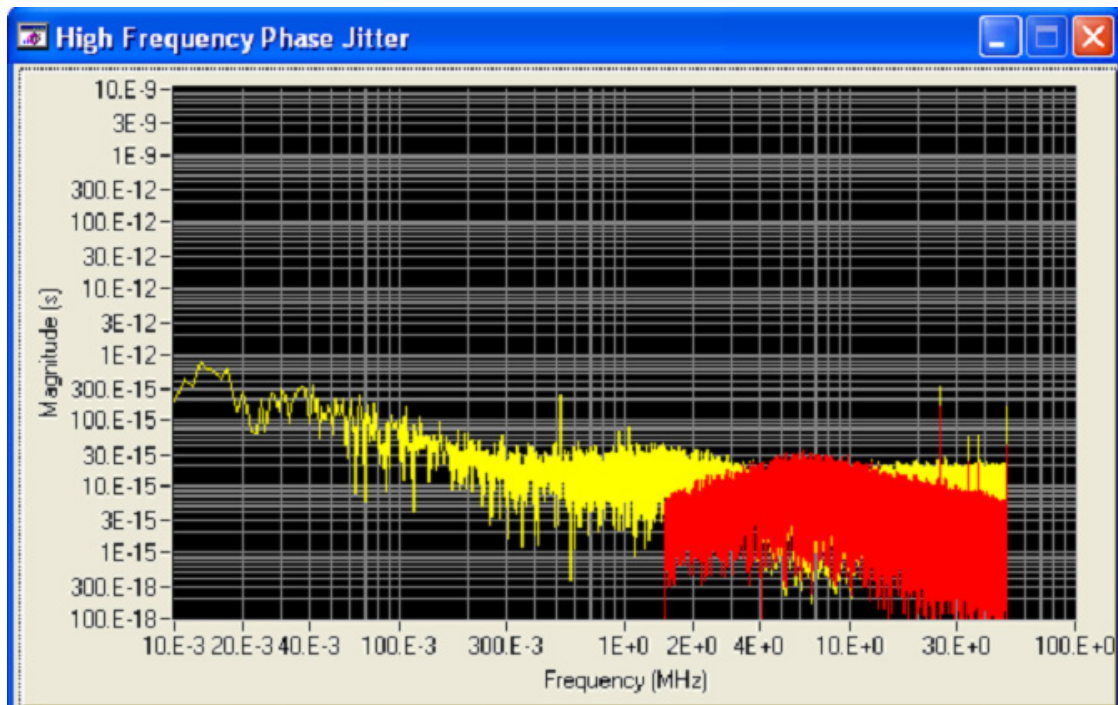
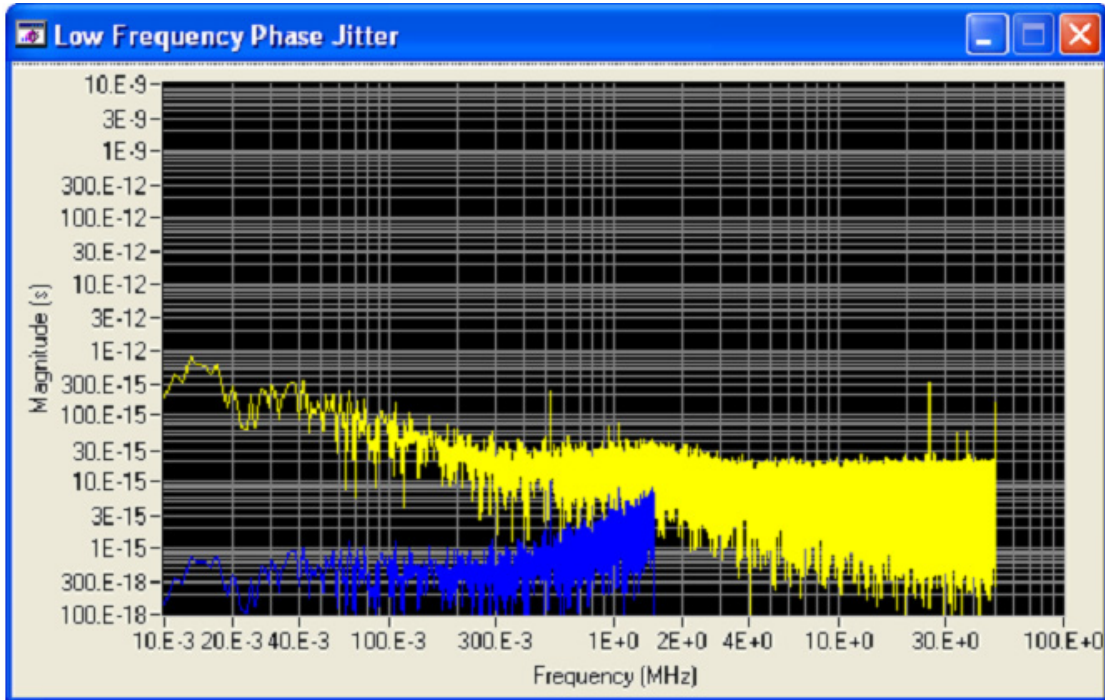

Figure 6. Application Load (Nominal drive strength device)



Phase Jitter

(PCIe 2.0 Check using Clock Jitter 1.3 Tool)



Phase Jitter (continued)

(PCIe 2.0 Check using Clock Jitter 1.3 Tool)

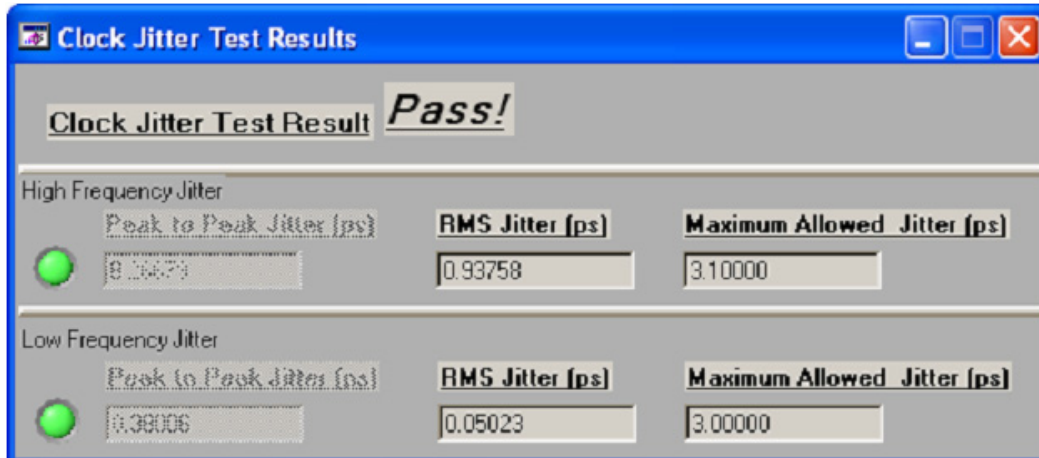

Absolute Maximum Conditions

Parameter	Description	Condition	Min	Max	Unit
V _{DD}	Supply voltage		-0.5	4.4	V
V _{IN} ^[1]	Input voltage, DC	Relative to V _{SS}	-0.5	V _{DD} + 0.5	V
T _S	Temperature, Storage	Non operating	-65	150	°C
T _J	Temperature, Junction		-	135	°C
ESD _{HBM}	Electrostatic discharge (ESD) protection (human body model)	JEDEC STD 22-A114-B	2000	-	V
UL-94	Flammability rating	At 1/8 in.	V-0		-
Θ _{JA} ^[2]	Thermal resistance, junction to ambient	0 m/s airflow	100		°C/W
		1 m/s airflow	91		
		2.5 m/s airflow	87		

Operating Conditions

Parameter	Description	Min	Max	Unit
V _{DD}	3.3 V supply voltage	3.135	3.465	V
	2.5 V supply voltage	2.375	2.625	V
T _A	Ambient temperature, industrial	-40	85	°C
T _{PU}	Power-up time for all V _{DD} to reach minimum specified voltage (ensure power ramp is monotonic)	0.05	500	ms

Notes

1. The voltage on any input or I/O pin cannot exceed the V_{DD} pins during power-up.
2. Simulated using Apache Sentinel TI software. The board is derived from the JEDEC multilayer standard. It measures 76 × 114 × 1.6 mm and has four layers of copper (2/1/1/2 oz.). The internal layers are 100% copper planes, while the top and bottom layers have 50% metallization. No vias are included in the model.

DC Electrical Characteristics

Parameter	Description	Test Conditions	Min	Typ	Max	Unit
I _{DD} ^[3]	Power supply current with output terminated	V _{DD} = 3.465 V, OE = V _{DD} , output terminated	–	–	125	mA
		V _{DD} = 2.625 V, OE = V _{DD} , output terminated	–	–	120	mA
V _{OD} ^[4]	LVDS differential output voltage	V _{DD} = 3.3 V or 2.5 V. R _{TERM} = 50 Ω between CLK and CLK#, High Drive Strength R _{TERM} = 100 Ω between CLK and CLK#, Normal Drive Strength	247	–	454	mV
ΔV _{OD} ^[4]	Change in V _{OD} between complementary output states	V _{DD} = 3.3 V or 2.5 V. R _{TERM} = 50 Ω between CLK and CLK#, High Drive Strength R _{TERM} = 100 Ω between CLK and CLK#, Normal Drive Strength	–	–	50	mV
V _{OS} ^[5]	LVDS offset output voltage	V _{DD} = 3.3 V or 2.5 V. R _{TERM} = 50 Ω between CLK and CLK#, High Drive Strength R _{TERM} = 100 Ω between CLK and CLK#, Normal Drive Strength	1.125	–	1.375	V
ΔV _{OS}	Change in V _{OS} between complementary output states	V _{DD} = 3.3 V or 2.5 V. R _{TERM} = 50 Ω between CLK and CLK#, High Drive Strength R _{TERM} = 100 Ω between CLK and CLK#, Normal Drive Strength	–	–	50	mV
I _{OZ}	Output leakage current	Three-state output, unterminated, measured on one pin while floating the other pin, OE = V _{SS}	–35	–	35	μA
I _{SB}	Standby supply current.	PD# = V _{SS}			200	μA
V _{IH}	Input high voltage, pin 5		0.7 × V _{DD}	–	V _{DD} + 0.3	V
V _{IL}	Input low voltage, pin 5		–0.3	–	0.3 × V _{DD}	V
I _{IH}	Input high current, pin 5	Input = V _{DD}	–	–	115	μA
I _{IL}	Input low current, pin 5	Input = V _{SS}	–50	–	–	μA
C _{IN}	Input capacitance, pin 5		–	15	–	pF
C _{INX}	Pin capacitance, XIN & XOUT		–	4.5	–	pF

Notes

- I_{DD} includes ~8 mA of current that is dissipated externally in the output termination resistor.
- Refer to [Figure 7](#) on page 11.
- Refer to [Figure 8](#) on page 11 and [Figure 9](#) on page 11.

AC Electrical Characteristics

Parameter ^[6, 7]	Description	Test Conditions	Min	Typ	Max	Unit
F_{OUT} ^[8]	Output frequency			See note 8		MHz
T_R, T_F ^[9]	Output rise or fall time	20% to 80% of full output swing	–	0.5	1.0	ns
$T_{Jitter(\phi)}$ ^[8, 10]	RMS phase jitter (Random)			See note 8		ps
T_{DC} ^[11]	Duty cycle	Measured at zero crossing point	45	–	55	%
T_{OHZ} ^[12]	Output disable time	Time from falling edge on OE to stopped outputs (asynchronous)	–	–	100	ns
T_{OE} ^[12]	Output enable time	Time from rising edge on OE to outputs at a valid frequency (asynchronous)	–	–	120	ns
T_{LOCK}	Startup time	Time for CLK to reach valid frequency measured from the time $V_{DD} = V_{DD(min)}$	–	–	5	ms

Crystal Characteristics

For SMD Package

Parameter	Description	Range 1	Range 2	Range 3	Unit
F_{IN}	Crystal frequency	8–14	14–28	28–48	MHz
R1	Maximum motional resistance (ESR)	135	50	30	Ω
CL	Parallel load capacitance (see Note 6 below)	8–18	8–14	8–12	pF
DL(max)	Maximum crystal drive level	300	300	300	μW

Notes

6. Not 100% tested, guaranteed by design and characterization.
7. Outputs are terminated with 50 Ω between CLK and CLK#. Refer to [Figure 4 on page 5](#).
8. Crystal frequency, output frequency, and typical phase jitter are listed in [Frequency Table on page 3](#).
9. Refer to [Figure 9 on page 11](#).
10. Refer to [Figure 13 on page 12](#).
11. Refer to [Figure 10 on page 11](#).
12. Refer to [Figure 11 on page 11](#).

Switching Waveforms

Figure 7. Output Voltage Swing

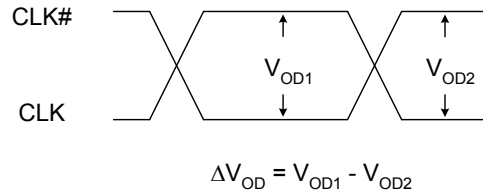

Figure 8. Output Offset Voltage (High Drive Strength)

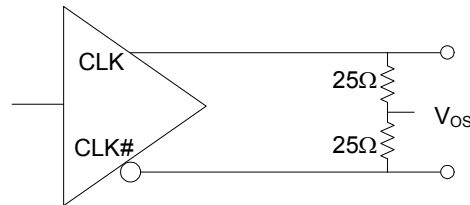

Figure 9. Output Rise or Fall Time (Normal Drive Strength)

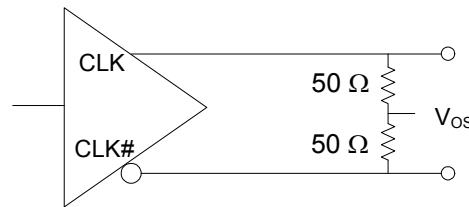

Figure 10. Duty Cycle Timing

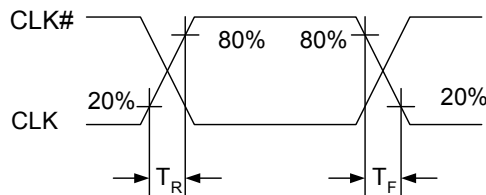
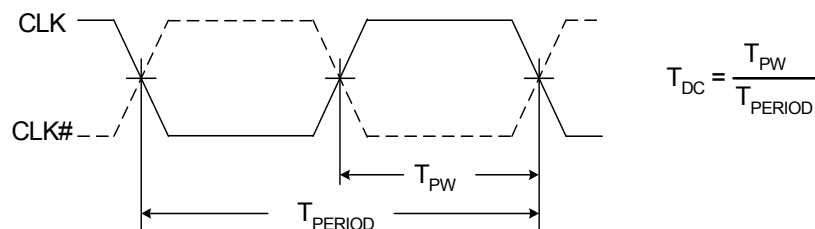

Figure 11. Output Enable and Disable Timing



Switching Waveforms (continued)

Figure 12. Output Enable and Disable Timing

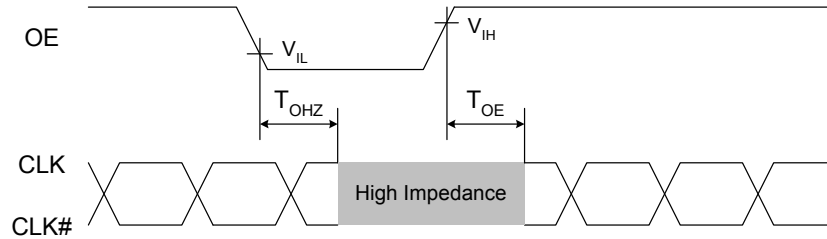
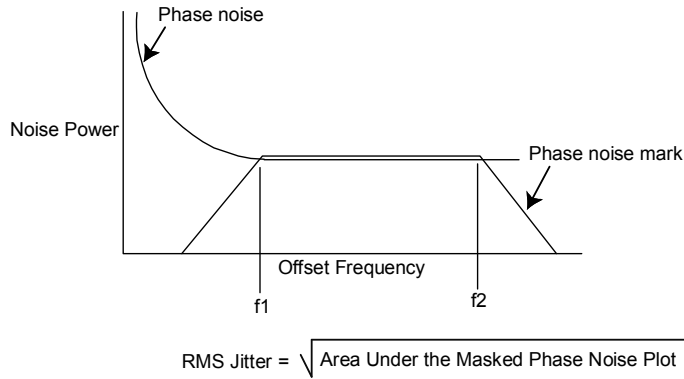

Figure 13. RMS Phase Jitter



Ordering Information

Part Number	Package Description	Product Flow
CY2XL12ZXI	8-pin TSSOP (Unprogrammed device)	Industrial, -40 °C to 85 °C
CY2XL12ZXIT	8-pin TSSOP (Unprogrammed device)	Industrial, -40 °C to 85 °C
CY2XL12ZXI01	8-pin TSSOP (Factory Programmed device)	Industrial, -40 °C to 85 °C
CY2XL12ZXI01T	8-pin TSSOP – Tape and Reel (Factory Programmed device)	Industrial, -40 °C to 85 °C
CY2XL12ZXI02	8-pin TSSOP (Factory Programmed device)	Industrial, -40 °C to 85 °C
CY2XL12ZXI02T	8-pin TSSOP – Tape and Reel (Factory Programmed device)	Industrial, -40 °C to 85 °C
CY2XL12ZXI03	8-pin TSSOP (Factory Programmed device)	Industrial, -40 °C to 85 °C
CY2XL12ZXI03T	8-pin TSSOP – Tape and Reel (Factory Programmed device)	Industrial, -40 °C to 85 °C
CY2XL12ZXI06	8-pin TSSOP (Factory Programmed device)	Industrial, -40 °C to 85 °C
CY2XL12ZXI06T	8-pin TSSOP – Tape and Reel (Factory Programmed device)	Industrial, -40 °C to 85 °C

Ordering Code Definitions

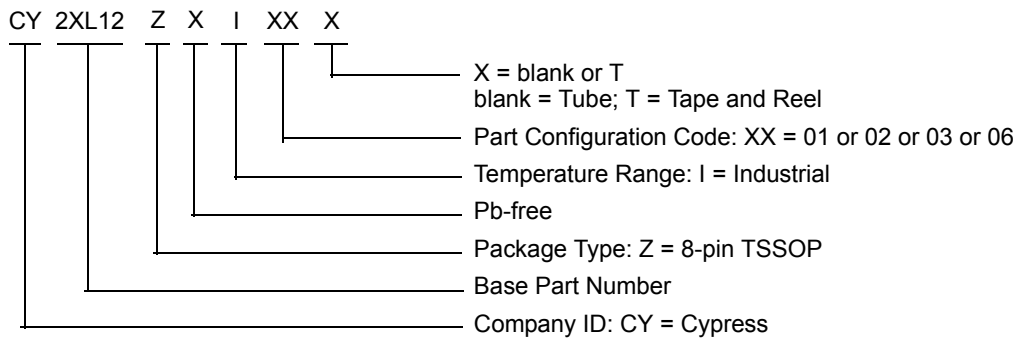

Package Drawing and Dimensions

Figure 14. 8-pin TSSOP (4.40 mm Body) Z08.173/ZZ08.173 Package Outline, 51-85093

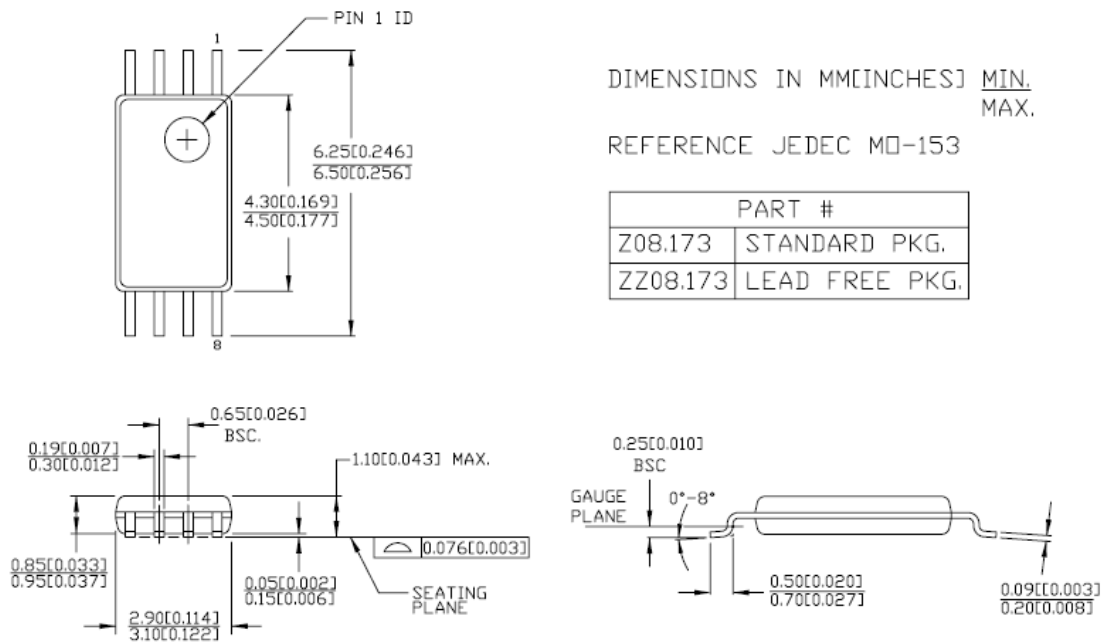

51-85093 *E

Acronyms

Acronym	Description
CMOS	Complementary Metal Oxide Semiconductor
ESD	Electrostatic Discharge
ESR	Equivalent Series Resistance
HBM	Human Body Model
I/O	Input/Output
JEDEC	Joint Electron Devices Engineering Council
LVDS	Low-Voltage Differential Signal
OE	Output Enable
PLL	Phase-Locked Loop
RMS	Root Mean Square
TSSOP	Thin Shrunk Small Outline Package
VCO	Voltage Controlled Oscillator
XO	Crystal Oscillator

Document Conventions

Units of Measure

Symbol	Units of Measure
°C	degree Celsius
kHz	kilohertz
MHz	megahertz
μA	microampere
mA	milliampere
mm	millimeter
ms	millisecond
mV	millivolt
ns	nanosecond
Ω	ohm
ppm	parts per million
%	percent
pF	picofarad
ps	picosecond
V	volt
W	watt

Document History Page

Document Title: CY2XL12, Low RMS Phase Jitter Programmable LVDS Clock Generator Document Number: 001-63176				
Rev.	ECN No.	Submission Date	Orig. of Change	Description of Change
**	2991849	07/28/2010	KVM	New data sheet.
*A	3117362	12/21/2010	BASH	Updated Features : Added "LVDS PCIe 2.0 Low Jitter XO". Added Phase Jitter . Added Document Conventions .
*B	3432906	11/09/2011	BASH	Updated Features . Updated Frequency Table . Updated Ordering Information (Added new part numbers CY2XL12ZXI03 and CY2XL12ZXI03T). Updated Package Drawing and Dimensions . Updated to new template.
*C	4120381	09/11/2013	CINM	Updated to new template. Completing Sunset Review.
*D	4700492	03/26/2015	TAVA	Updated Document Title to read as "CY2XL12, Low RMS Phase Jitter Programmable LVDS Clock Generator". Updated Logic Block Diagram . Updated Pinouts : Updated Figure 1 . Updated Package Drawing and Dimensions : spec 51-85093 – Changed revision from *D to *E.
*E	5449404	09/26/2016	XHT	Updated to new template. Completing Sunset Review.

Sales, Solutions, and Legal Information

Worldwide Sales and Design Support

Cypress maintains a worldwide network of offices, solution centers, manufacturer’s representatives, and distributors. To find the office closest to you, visit us at [Cypress Locations](#).

Products

ARM® Cortex® Microcontrollers	cypress.com/arm
Automotive	cypress.com/automotive
Clocks & Buffers	cypress.com/clocks
Interface	cypress.com/interface
Internet of Things	cypress.com/iot
Lighting & Power Control	cypress.com/powerpsoc
Memory	cypress.com/memory
PSoC	cypress.com/psoc
Touch Sensing	cypress.com/touch
USB Controllers	cypress.com/usb
Wireless/RF	cypress.com/wireless

PSoC® Solutions

[PSoC 1](#) | [PSoC 3](#) | [PSoC 4](#) | [PSoC 5LP](#)

Cypress Developer Community

[Forums](#) | [Projects](#) | [Video](#) | [Blogs](#) | [Training](#) | [Components](#)

Technical Support

cypress.com/support

© Cypress Semiconductor Corporation, 2010-2016. This document is the property of Cypress Semiconductor Corporation and its subsidiaries, including Spansion LLC ("Cypress"). This document, including any software or firmware included or referenced in this document ("Software"), is owned by Cypress under the intellectual property laws and treaties of the United States and other countries worldwide. Cypress reserves all rights under such laws and treaties and does not, except as specifically stated in this paragraph, grant any license under its patents, copyrights, trademarks, or other intellectual property rights. If the Software is not accompanied by a license agreement and you do not otherwise have a written agreement with Cypress governing the use of the Software, then Cypress hereby grants you a personal, non-exclusive, nontransferable license (without the right to sublicense) (1) under its copyright rights in the Software (a) for Software provided in source code form, to modify and reproduce the Software solely for use with Cypress hardware products, only internally within your organization, and (b) to distribute the Software in binary code form externally to end users (either directly or indirectly through resellers and distributors), solely for use on Cypress hardware product units, and (2) under those claims of Cypress's patents that are infringed by the Software (as provided by Cypress, unmodified) to make, use, distribute, and import the Software solely for use with Cypress hardware products. Any other use, reproduction, modification, translation, or compilation of the Software is prohibited.

TO THE EXTENT PERMITTED BY APPLICABLE LAW, CYPRESS MAKES NO WARRANTY OF ANY KIND, EXPRESS OR IMPLIED, WITH REGARD TO THIS DOCUMENT OR ANY SOFTWARE OR ACCOMPANYING HARDWARE, INCLUDING, BUT NOT LIMITED TO, THE IMPLIED WARRANTIES OF MERCHANTABILITY AND FITNESS FOR A PARTICULAR PURPOSE. To the extent permitted by applicable law, Cypress reserves the right to make changes to this document without further notice. Cypress does not assume any liability arising out of the application or use of any product or circuit described in this document. Any information provided in this document, including any sample design information or programming code, is provided only for reference purposes. It is the responsibility of the user of this document to properly design, program, and test the functionality and safety of any application made of this information and any resulting product. Cypress products are not designed, intended, or authorized for use as critical components in systems designed or intended for the operation of weapons, weapons systems, nuclear installations, life-support devices or systems, other medical devices or systems (including resuscitation equipment and surgical implants), pollution control or hazardous substances management, or other uses where the failure of the device or system could cause personal injury, death, or property damage ("Unintended Uses"). A critical component is any component of a device or system whose failure to perform can be reasonably expected to cause the failure of the device or system, or to affect its safety or effectiveness. Cypress is not liable, in whole or in part, and you shall and hereby do release Cypress from any claim, damage, or other liability arising from or related to all Unintended Uses of Cypress products. You shall indemnify and hold Cypress harmless from and against all claims, costs, damages, and other liabilities, including claims for personal injury or death, arising from or related to any Unintended Uses of Cypress products.

Cypress, the Cypress logo, Spansion, the Spansion logo, and combinations thereof, WICED, PSoC, CapSense, EZ-USB, F-RAM, and Traveo are trademarks or registered trademarks of Cypress in the United States and other countries. For a more complete list of Cypress trademarks, visit cypress.com. Other names and brands may be claimed as property of their respective owners.