

Features

- Reduces Systemic EMI.
- Modulates external clocks including crystals, crystal oscillators and ceramic resonators.
- 3–5 Volt power supply.
- Modulation programmable with simple external loop filter (LF).
- 4 to 68 MHz operating frequency range.
- Digitally controlled modulation.
- TTL/CMOS compatible outputs.
- Center Spread Modulation.
- Low short term jitter.
- Bi-directional buffers for reduced pin count.
- Unmodulated Reference Clock Output.
- Low Power Dissipation;
 - 3.3 VDC = 21 mW - typical
 - 5.0 VDC = 70 mW - typical
- Available in 8-pin SOIC package.

Functional Description

The CYIFS741 is a frequency spreading EMI attenuator designed for the purpose of reducing electromagnetic interference (EMI) found in today's high speed digital systems. The CYIFS741 uses a proprietary technique to modulate the output clock frequency, Modout. By modulating the frequency of the digital clock, measured EMI at the fundamental and harmonic frequencies is greatly reduced. This reduction in radiated energy can significantly reduce the cost of complying with regulatory requirements without degrading digital waveforms.

The CYIFS741 is a very simple device to use. By programming the two range select lines, RS0 and RS1, the CYIFS741 can operate over a very wide range of input frequencies. By utilizing bi-directional buffer design, the pin count of the CYIFS741 is kept to a minimum. Bi-directional Buffers is a method of providing an input control signal and an output driver circuit on the same pin. Bi-Directional Buffers is discussed further on page 6. The CYIFS741 also provides a buffered reference clock output, Refout, which can be turned on or off by controlling the Ref_Off pin. The Refout clock can be used to drive system logic that can not tolerate frequency spreading, or as a comparison of EMI reduction with respect to the Modout driver. The CYIFS741 has a simple frequency selection table that allows it to operate from 4 MHz to 68 MHz in four separate ranges. The bandwidth of the frequency spread at Modout is determined by the values of the loop filter components. The modulation rate is determined by the input frequency and the input frequency range selected. The bandwidth of the CYIFS741 can be programmed from as little as 0.3% up to as much as 4.0% by selecting the proper loop filter. It is for this reason that the CYIFS741 uses an external loop filter (LF), in contrast to an internal loop filter type device which would severely limit the use of a wide range of bandwidths.

Block Diagram

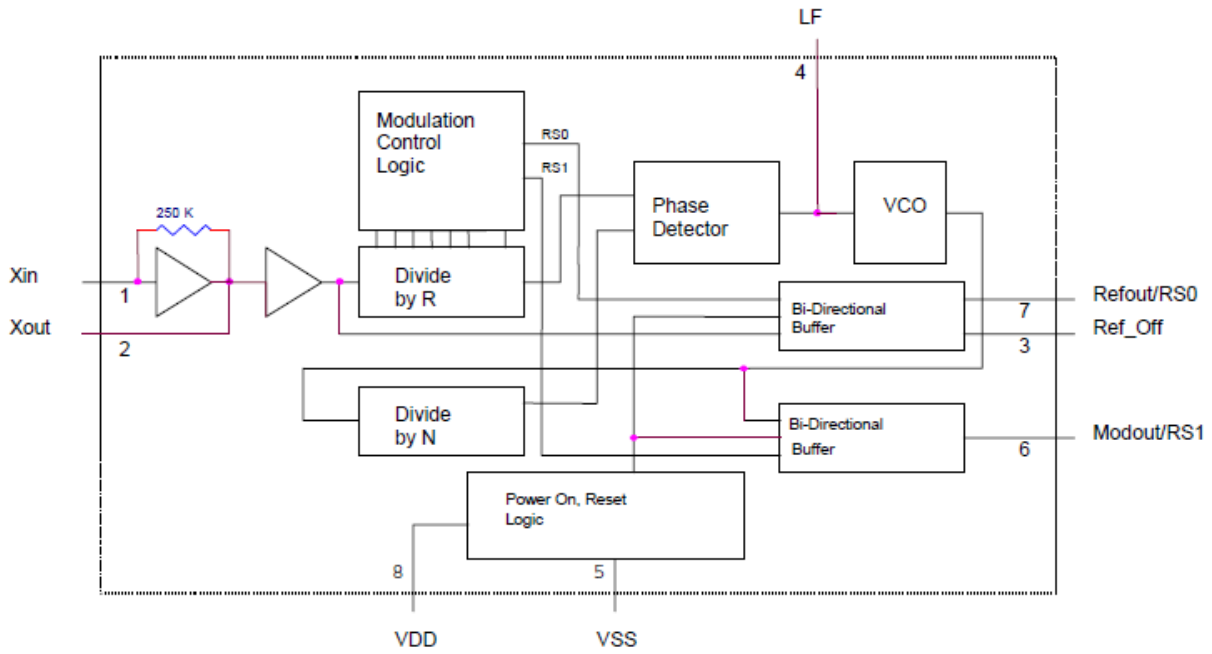

Not Recommended for New Designs

Contents

Pin Configurations	4	Timing Characteristics	15
Pin Definitions	4	Ordering Information	15
Frequency Range Selection Table	5	Ordering Code Definitions	15
Functional Overview	6	Package Diagram	16
Bi-directional Buffers	6	Acronyms	17
Loop Filters	6	Document Conventions	17
SSCG Modulation Profile	9	Units of Measure	17
Theory of Operation	10	Document History Page	18
EMI	10	Sales, Solutions, and Legal Information	19
SSCG	10	Worldwide Sales and Design Support	19
Modulation Rate	12	Products	19
Application Notes and Schematics	13	PSoC® Solutions	19
Calculating dB Reduction	13	Cypress Developer Community	19
Absolute Maximum Ratings	14	Technical Support	19
Electrical Characteristics	14		

Not Recommended for New Designs

Pin Configurations

Figure 1. CYIFS741, SOIC Package Pin Assignment

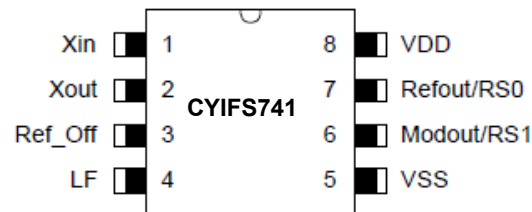

Pin Definitions

Pin No.	Pin Name	I/O	Type	Description
1, 2	X _{IN} , X _{OUT}	I/O	CMOS/TTL	Pins form an on-chip reference oscillator when connected to terminals of an external parallel resonant crystal. X _{IN} may be connected to TTL/CMOS external clock source. If X _{IN} is connected to an external clock other than a crystal, leave X _{OUT} (pin 2) unconnected.
3	Ref_Off	I	CMOS/TTL	Input control pin determines the on/off state of Refout. Ref_Off has an internal pull down resistor and defaults to Refout = Off. To enable Refout, set Ref_Off to logic high.
4	LF	O	Analog	Single ended tri-state output of the phase detector. A two pole passive loop filter is connected to LF. See Table 1 on page 7 and Table 2 on page 8 for proper values.
5	V _{SS}	–	Ground	Circuit Ground.
6	Modout/RS1	I/O	CMOS/TTL	Bi-Directional pin used for range selection input and Modout driver output. During power up, RS1 serves as an input control line for selecting the proper frequency operating range. After RS1 is latched into an internal register, this pin becomes an output for the modulated Modout driver. Refer to Bi-directional Buffers on page 6 for more information. Modout/RS1 has an internal 250 kΩ pull-up resistor to V _{DD} .
7	Refout/RS0	I/O	CMOS/TTL	Bi-Directional pin used for range selection input and Refout driver output. During power up, RS0 serves as an input control line for selecting the proper frequency operating range. After power has reached V _{DD} /3, RS0 is latched into a register and this pin becomes an output pin for the Refout driver. Refout is tri-stated when Ref_Off is at a logic low.
8	V _{DD}	–	Power	Positive Circuit Power Supply.

Frequency Range Selection Table

X _{IN} Range	RS1	RS0
4–8 MHz	0	0
8–16 MHz	0	1
16–40 MHz	1	0
40–68 MHz	1	1

This device contains circuitry to protect the inputs against damage due to high static voltages or electric fields; however, precautions should be taken to avoid application of any voltage higher than the absolute maximum rated voltages to this circuit. For proper operation, V_{IN} and V_{OUT} should be constrained to the range, V_{SS} < (V_{IN} or V_{OUT}) < V_{DD}. All digital inputs are tied high or low internally. Refers to electrical specifications for operating supply range.

Figure 2. Frequency vs. I_{dd}

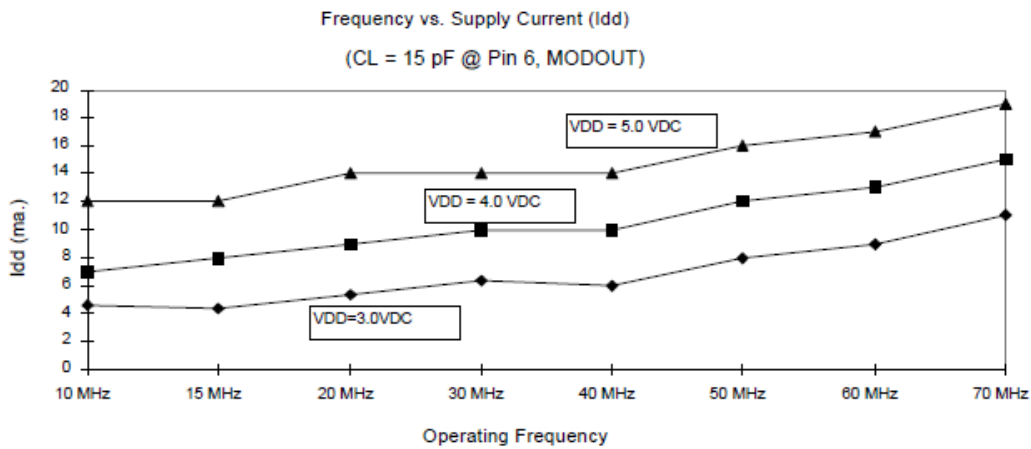

Not Recommended for New Designs

Functional Overview

Bi-directional Buffers

Two pins on the CYIFS741 are connected to bi-directional buffers. Using bi-directional buffers is a method of sharing an input circuit and an output circuit with the same pin on the IC assembly, thereby reducing the pin count. Each bi-directional I/O acts as an input during power up and as an output after power has reached a certain voltage. For the CYIFS741, that voltage is approximately $V_{DD}/3$. At $V_{DD}/3$, the CYIFS741 latches the logic state of the respective line into an internal register for as long as power is applied to the CYIFS741. After $V_{DD}/3$ has been reached and the power on reset has occurred, the respective pin is switched from an input gate to an output driver. This pin remains an output driver for as long as power is applied.

Loop Filters

The CYIFS741 requires an external loop filter to provide the proper operation and bandwidth for a given input frequency. Since the CYIFS741 operates over a wide range of frequencies, the loop filter will change depending on the frequency of operation. The following loop filter values are recommended for best performance and modulation profile at 5.0 Volts and 3.3 Volts V_{DD} , measured across pin 8 (V_{DD}) and 5 (V_{SS}).

Figure 3. External Loop Filter

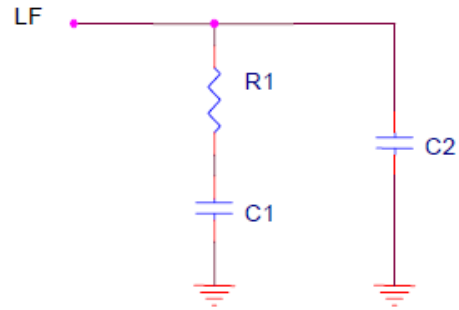

The [Table 1 on page 7](#) and [Table 2 on page 8](#) contain the loop filter values for a power supply voltage of 5.0 and 3.3 VDC, +/-10%. The values in both [Table 1 on page 7](#) and [Table 2 on page 8](#) were bench tested for accuracy and optimal performance. The loop filter values were determined by taking 4 MHz segments of the overall operating range and testing for the optimal performance at the center frequency of each 4 MHz band. This means that in the first band in the table below, 4–8 MHz, the loop filter values shown in the table produce the most optimized performance for 6 MHz. It is possible to deviate slightly from these values for optimal performance at some other center frequency. Also note that the values listed in these tables are all commonly manufactured components.

Not Recommended for New Designs

Table 1. Recommended Loop Filter Values ($V_{DD} = 5.0 \text{ VDC}$, $\pm 10\%$)^[1, 2]

Input (MHz)	RS1	RS0	BW = 1% ($\pm 0.5\%$)	BW = 2% ($\pm 1\%$)	BW = 3% ($\pm 1.5\%$)	BW = 4% ($\pm 2\%$)
4–8	0	0	R1 = 2.2K C1 = 270 pF C2 = 22 pF	R1 = 2.2K C1 = 120 pF C2 = 22 pF	R1 = 2.2K C1 = 82 pF C2 = 22 pF	R1 = 2.2K C1 = 56 pF C2 = 22 pF
8–12	0	1	R1 = 2.2K C1 = 470 pF C2 = 22 pF	R1 = 2.2K C1 = 220 pF C2 = 22 pF	R1 = 2.2K C1 = 150 pF C2 = 22 pF	R1 = 2.2K C1 = 100 pF C2 = 22 pF
12–16	0	1	R1 = 2.2K C1 = 180 pF C2 = 22 pF	R1 = 2.2K C1 = 82 pF C2 = 22 pF	R1 = 2.2K C1 = 56 pF C2 = 22 pF	R1 = 2.2K C1 = 33 pF C2 = 22 pF
16–20	1	0	R1 = 2.2K C1 = 680 pF C2 = 22 pF	R1 = 2.2K C1 = 330 pF C2 = 22 pF	R1 = 2.2K C1 = 220 pF C2 = 22 pF	R1 = 2.2K C1 = 150 pF C2 = 22 pF
20–24	1	0	R1 = 2.2K C1 = 470 pF C2 = 22 pF	R1 = 2.2K C1 = 220 pF C2 = 22 pF	R1 = 2.2K C1 = 150 pF C2 = 22 pF	R1 = 2.2K C1 = 100 pF C2 = 22 pF
24–28	1	0	R1 = 2.2K C1 = 220 pF C2 = 22 pF	R1 = 2.2K C1 = 100 pF C2 = 22 pF	R1 = 2.2K C1 = 82 pF C2 = 22 pF	R1 = 2.2K C1 = 56 pF C2 = 22 pF
28–32	1	0	R1 = 4.7K C1 = 220 pF C2 = 0 pF	R1 = 4.7K C1 = 100 pF C2 = 0 pF	R1 = 4.7K C1 = 68 pF C2 = 0 pF	R1 = 4.7K C1 = 47 pF C2 = 0 pF
32–36	1	0	R1 = 4.7K C1 = 120 pF C2 = 0 pF	R1 = 4.7K C1 = 68 pF C2 = 0 pF	R1 = 4.7K C1 = 47 pF C2 = 7 pF	R1 = 4.7K C1 = 27 pF C2 = 15 pF
36–40	1	0	R1 = 4.7K C1 = 100 pF C2 = 0 pF	R1 = 4.7K C1 = 33 pF C2 = 0 pF	R1 = 4.7K C1 = 27 pF C2 = 0 pF	R1 = 4.7K C1 = 18 pF C2 = 0 pF
40–44	1	1	R1 = 2.2K C1 = 470 pF C2 = 0 pF	R1 = 2.2K C1 = 180 pF C2 = 22 pF	R1 = 2.2K C1 = 120 pF C2 = 22 pF	R1 = 2.2K C1 = 82 pF C2 = 22 pF
44–48	1	1	R1 = 2.2K C1 = 330 pF C2 = 0 pF	R1 = 2.2K C1 = 150 pF C2 = 22 pF	R1 = 2.2K C1 = 120 pF C2 = 16 pF	R1 = 2.2K C1 = 82 pF C2 = 10 pF
48–52	1	1	R1 = 2.2K C1 = 270 pF C2 = 0 pF	R1 = 2.2K C1 = 120 pF C2 = 0 pF	R1 = 2.2K C1 = 100 pF C2 = 0 pF	R1 = 2.2K C1 = 68 pF C2 = 0 pF
52–56	1	1	R1 = 2.2K C1 = 220 pF C2 = 0 pF	R1 = 2.2K C1 = 100 pF C2 = 0 pF	R1 = 2.2K C1 = 82 pF C2 = 0 pF	R1 = 2.2K C1 = 56 pF C2 = 0 pF
56–60	1	1	R1 = 2.2K C1 = 220 pF C2 = 0 pF	R1 = 2.2K C1 = 100 pF C2 = 0 pF	R1 = 2.2K C1 = 68 pF C2 = 0 pF	R1 = 2.2K C1 = 39 pF C2 = 0 pF
60–64	1	1	R1 = 7.5K C1 = 120 pF C2 = 33 pF	R1 = 7.5K C1 = 68 pF C2 = 0 pF	R1 = 7.5K C1 = 47 pF C2 = 0 pF	R1 = 7.5K C1 = 33 pF C2 = 0 pF
64–68	1	1	R1 = 7.5K C1 = 120 pF C2 = 33 pF	R1 = 7.5K C1 = 68 pF C1 = 0 pF	R1 = 7.5K C1 = 47 pF C2 = 0 pF	R1 = 7.5K C1 = 27 pF C2 = 0 pF

Not Recommended for New Designs

Notes

- 0 pF means that the capacitor is removed.
- When clock frequency is on boundary between two ranges, it is recommended that the higher range be used.

Table 2. Recommended Loop Filter Values ($V_{DD} = 3.3 \text{ VDC}$, $\pm 10\%$) ^[3, 4]

Input (MHz)	RS1	RS0	BW = 1% ($\pm 0.5\%$)	BW = 2% ($\pm 1\%$)	BW = 3% ($\pm 1.5\%$)	BW = 4% ($\pm 2\%$)
4–8	0	0	R1 = 2.2K C1 = 220 pF C2 = 22 pF	R1 = 2.2K C1 = 100 pF C2 = 22 pF	R1 = 2.2K C1 = 68 pF C2 = 22 pF	R1 = 2.2K C1 = 39 pF C2 = 22 pF
8–12	0	1	R1 = 2.2K C1 = 470 pF C2 = 22 pF	R1 = 2.2K C1 = 220 pF C2 = 22 pF	R1 = 2.2K C1 = 150 pF C2 = 22 pF	R1 = 2.2K C1 = 100 pF C2 = 22 pF
12–16	0	1	R1 = 2.2K C1 = 120 pF C2 = 22 pF	R1 = 2.2K C1 = 56 pF C2 = 22 pF	R1 = 2.2K C1 = 39 pF C2 = 22 pF	R1 = 2.2K C1 = 27 pF C2 = 8 pF
16–20	1	0	R1 = 2.2K C1 = 680 pF C2 = 22 pF	R1 = 2.2K C1 = 390 pF C2 = 22 pF	R1 = 2.2K C1 = 270 pF C2 = 22 pF	R1 = 2.2K C1 = 180 pF C2 = 22 pF
20–24	1	0	R1 = 2.2K C1 = 560 pF C2 = 22 pF	R1 = 2.2K C1 = 220 pF C2 = 22 pF	R1 = 2.2K C1 = 120 pF C2 = 22 pF	R1 = 2.2K C1 = 82 pF C2 = 22 pF
24–28	1	0	R1 = 2.2K C1 = 220 pF C2 = 22 pF	R1 = 2.2K C1 = 82 pF C2 = 22 pF	R1 = 2.2K C1 = 56 pF C2 = 22 pF	R1 = 2.2K C1 = 39 pF C2 = 10 pF
28–32	1	0	R1 = 4.7K C1 = 180 pF C2 = 0 pF	R1 = 4.7K C1 = 68 pF C2 = 0 pF	R1 = 4.7K C1 = 39 pF C2 = 0 pF	R1 = 4.7K C1 = 27 pF C2 = 0 pF
32–36	1	0	R1 = 4.7K C1 = 82 pF C2 = 0 pF	R1 = 4.7K C1 = 33 pF C2 = 0 pF	R1 = 4.7K C1 = 22 pF C2 = 0 pF	R1 = 4.7K C1 = 12 pF C2 = 0 pF
36–40	1	1	R1 = 47K C1 = 1.0 μ F C2 = 390 pF	R1 = 47K C1 = 1.0 μ F C2 = 220 pF	R1 = 47K C1 = 1.0 μ F C2 = 150 pF	R1 = 47K C1 = 1.0 μ F C2 = 100 pF
40–44	1	1	R1 = 2.2K C1 = 680 pF C2 = 0 pF	R1 = 2.2K C1 = 270 pF C2 = 0 pF	R1 = 2.2K C1 = 180 pF C2 = 10 pF	R1 = 2.2K C1 = 120 pF C2 = 10 pF
44–48	1	1	R1 = 2.2K C1 = 330 pF C2 = 0 pF	R1 = 2.2K C1 = 180 pF C2 = 0 pF	R1 = 2.2K C1 = 120 pF C2 = 0 pF	R1 = 2.2K C1 = 82 pF C2 = 0 pF
48–52	1	1	R1 = 2.2K C1 = 270 pF C2 = 0 pF	R1 = 2.2K C1 = 120 pF C2 = 0 pF	R1 = 2.2K C1 = 82 pF C2 = 0 pF	R1 = 2.2K C1 = 56 pF C2 = 0 pF
52–56	1	1	R1 = 2.2K C1 = 220 pF C2 = 0 pF	R1 = 2.2K C1 = 100 pF C2 = 0 pF	R1 = 2.2K C1 = 68 pF C2 = 0 pF	R1 = 2.2K C1 = 33 pF C2 = 0 pF
56–60	1	1	R1 = 2.2K C1 = 150 pF C2 = 0 pF	R1 = 2.2K C1 = 68 pF C2 = 5 pF	R1 = 3.3K C1 = 47 pF C2 = 12 pF	R1 = 4.7K C1 = 33 pF C2 = 22 pF
60–64	1	1	R1 = 4.7K C1 = 100 pF C2 = 0 pF	R1 = 4.7K C1 = 47 pF C2 = 0 pF	R1 = 4.7K C1 = 27 pF C2 = 0 pF	R1 = 4.7K C1 = 18 pF C2 = 0 pF
64–68	1	1	R1 = 7.5K C1 = 68 pF C2 = 0 pF	R1 = 7.5K C1 = 33 pF C1 = 0 pF	R1 = 7.5K C1 = 22 pF C2 = 0 pF	R1 = 7.5K C1 = 15 pF C2 = 0 pF

Not Recommended for New Designs

Notes

3. 0 pF means that the capacitor is removed.
4. When clock frequency is on boundary between two ranges, it is recommended that the higher range be used.

SSCG Modulation Profile

The modulation rate of the CYIFS741 is determined by the input frequency and the operating range. The input frequency is divided by a fixed number, depending on the operating range that is selected. The modulation rate of the CYIFS741 can be determined from the Table 3.

Example: Freq. of X_{IN} = 25 MHz

Operating Range = 16–40 MHz

Modrate = $F_{xin}/240 = 104.166$ kHz.

Table 3. Chart for determination of modulation rate of CYIFS741

X_{IN} Range	Mod. rate divider
4–8 MHz	60
8–16 MHz	120
16–40 MHz	240
40–68 MHz	480

With the correct loop filter connected to pin 4, the following profile will provide the best EMI reduction. This profile can be seen on a Time Domain Analyzer.

Figure 4. Frequency Profile in Time Domain

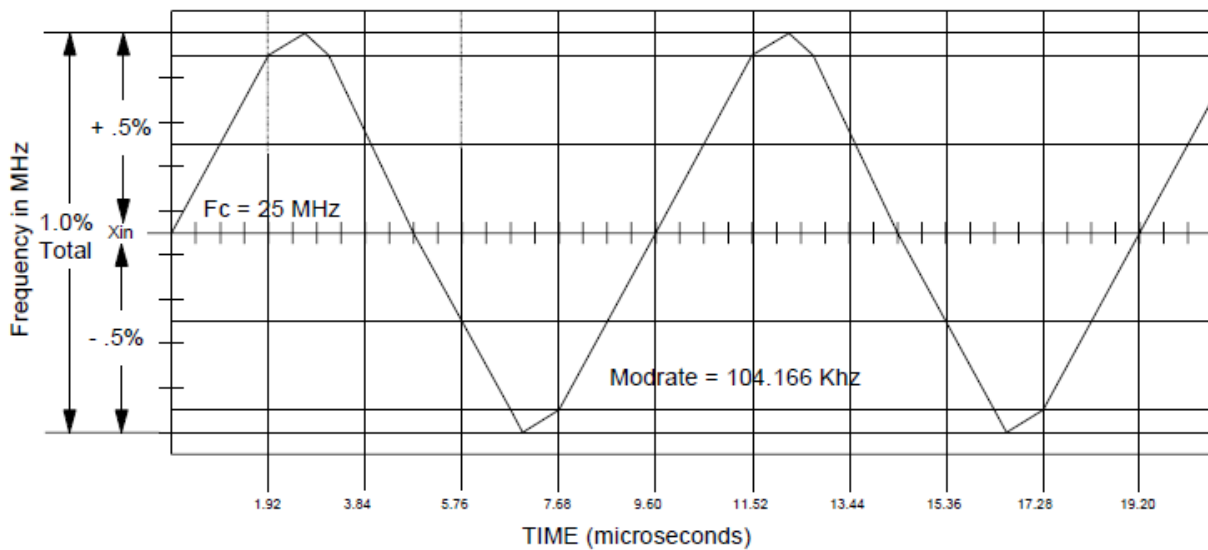

Not Recommended for New Designs

Theory of Operation

The CYIFS741 is a Phase Lock Loop (PLL) type clock generator using Direct Digital Synthesis (DDS). By precisely controlling the bandwidth of the output clock, the CYIFS741 becomes a Low EMI clock generator. The theory and detailed operation of the CYIFS741 will be discussed in the following sections.

EMI

All clocks generate unwanted energy in their harmonics. Conventional digital clocks are square waves with a duty cycle that is very close to 50%. Because of the 50/50 duty cycle, digital clocks generate most of their harmonic energy in the odd harmonics, i.e.; 3rd, 5th, 7th etc. It is possible to reduce the amount of energy contained in the fundamental and harmonics by increasing the bandwidth of the fundamental clock frequency. Conventional digital clocks have a very high Q factor, which means that all of the energy at that frequency is concentrated in a very narrow bandwidth, consequently, higher energy peaks.

Regulatory agencies test electronic equipment by the amount of peak energy radiated from the equipment. By reducing the peak energy at the fundamental and harmonics, the equipment under test is able to satisfy agency requirements for Electro-Magnetic Interference (EMI). Conventional methods of reducing EMI have been to use shielding, filtering, multi-layer PCB's etc. The CYIFS741 uses the approach of reducing the peak energy in the clock by increasing the clock bandwidth, and lowering the Q.

SSCG

The CYIFS741 uses a proprietary technique to modulate the clock over a very narrow bandwidth and controlled rate of change, both peak and cycle to cycle. The CYIFS741 takes a narrow band digital reference clock in the range 4–68 MHz and produces a clock that sweeps between a controlled start and stop frequency and precise rate of change. To understand what happens to an SSCG clock, consider that we have a 20 MHz clock with a 50% duty cycle. From a 20 MHz clock we know the following.

Figure 5. SSCG clock

Clock Frequency = $F_c = 20 \text{ MHz}$
 Clock Period = $T_c = 1/20 \text{ MHz} = 50 \text{ ns}$

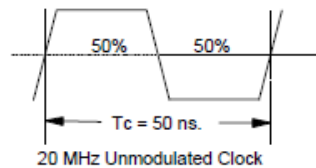

Consider that this 20 MHz clock is applied to the Xin input of the CYIFS741, either as an externally driven clock or as the result of a parallel resonant crystal connected to pins 1 and 2 of the CYIFS741. Also consider that the CYIFS741 is operating from a 5 Volt DC power supply and the loop filter is set for a total bandwidth spread of 2%. Refer to Table 1 on page 7.

Figure 6. Perfect clock with no noise

From the above parameters, the output clock at Modout will be sweeping symmetrically around a center frequency of 20 MHz.

The minimum and maximum extremes of this clock will be +200 kHz and -200 kHz. So, we have a clock that is sweeping from 19.8 MHz to 20.2 MHz and back again. If we were to look at this clock on a spectrum analyzer we would see the picture in Figure 6. Keep in mind that this is a drawing of a perfect clock with no noise.

We see that the original 20 MHz reference clock is at the center Frequency, F_c , and the minimum and maximum extremes are positioned symmetrically about the center frequency. This type of modulation is called Center-Spread. Figure 6 illustrates this as it is seen on a spectrum analyzer.

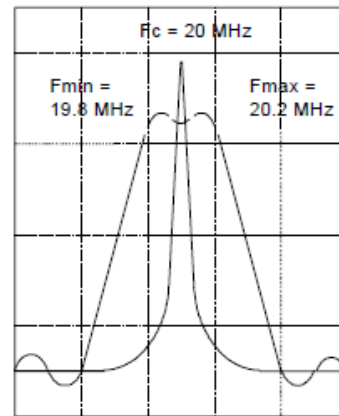
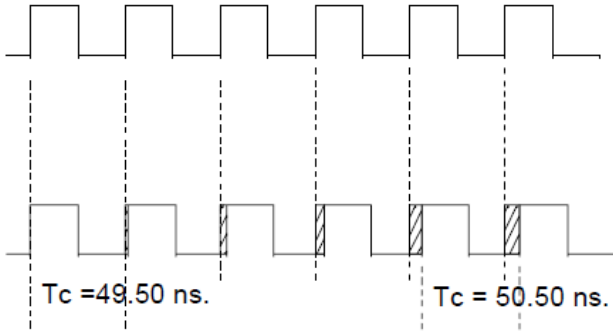

Figure 7 on page 11 shows a 20 MHz clock as it would be seen on an oscilloscope. The top trace is the non-modulated reference clock, or the Refout clock at pin 7. The bottom trace is the modulated clock at pin 6. From this comparison chart you can see that the frequency is decreasing and the period of each successive clock increasing. The T_c measurements on the left and right of the bottom trace indicate the max. and min. extremes of the clock. Intermediate clock changes are small and accumulate to achieve the total period deviation. The reverse of

this Figure would show the clock going from min. extreme back to the high extreme.

Figure 7. Period Comparison Chart



The CYIFS741 is a center spread clock, meaning that it symmetrically spreads above and below the reference frequency.

Looking at Figure 6 on page 10, you will note that the peak amplitude of the 20 MHz non-modulated clock is higher than the wideband modulated clock. This difference in peak amplitudes between modulated and unmodulated clocks is the reason why SSCG clocks are so effective in digital systems. The Figure 6 on page 10 refers to the fundamental frequency of a clock. A very important characteristic of the SSCG clock is that the bandwidth of the harmonics is multiplied by the harmonic number. In other words, if the bandwidth of a 20 MHz clock is 200 kHz, the bandwidth of the 3rd harmonic will be 3 times 200 kHz, or 600 kHz. The amount of bandwidth is relative to the amount of energy in the clock. Consequently, the wider the bandwidth, the greater the energy reduction of the clock.

Most applications will not have a problem meeting agency specifications at the fundamental frequency. It is the higher harmonics that usually cause the most problems. With an SSCG clock, the bandwidth and peak energy reduction increases with the harmonic number. Consider that the 11th harmonic of a 20 MHz clock is 220 MHz. With a total spread of 200 kHz at 20 MHz, the spread at the 11th harmonic would be 2.20 MHz which greatly reduces the peak energy content.

The difference in the peak energy of the modulated clock and the non-modulated clock in typical applications will see a 2–3 dB reduction at the fundamental and as much as 8–10 dB reduction at the intermediate harmonics, 3rd, 5th, 7th etc. At the higher harmonics, it is quite possible to reduce the peak harmonic energy, compared to the unmodulated clock, by as much as 12 to 18 dB.

The following images are actual scans of the CYIFS741. These scans are from a spectrum analyzer and time domain analyzer of the CYIFS741 at various frequencies running at 3.3 Volts DC.

Figure 8 shows a modulated 10 MHz clock at Modout of the CYIFS741. The following parameters apply to this scan;

- Fin = 10 MHz.
- BW = 2% (total)
- Vertical scale = 6 dB/div.

From this scan it can be seen the bandwidth of the clock is wider than a conventional clock. Notice the EMI filters displayed at the bottom of the image. This is the same filter settings that are used by regulatory agencies.

Figure 8. Modulated 10 MHz clock at Modout of CYIFS741

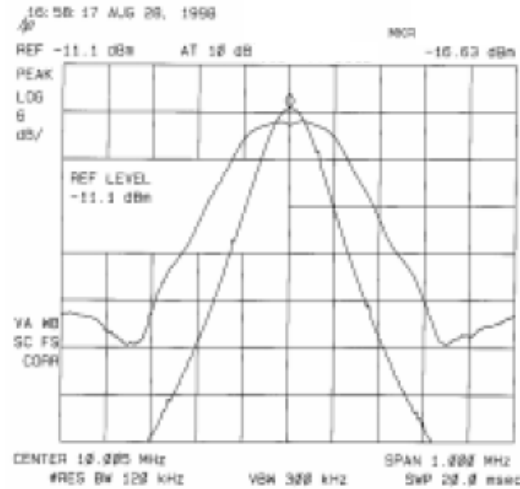

It is clear from Figure 8, that the peak amplitude of the modulated clock is lower in amplitude than the non-modulated clock. In fact, this image indicates that the difference between the two peaks is approximately 2 dB.

Figure 9, shows the 3rd Harmonic of the 10 MHz clock in Figure 8. The big difference here is that the bandwidth of the 3rd harmonic is 3 times greater than the bandwidth at the fundamental frequency. Since the energy is spread over a much wider bandwidth, the peak energy reduction will be greater. As can be seen in this picture, the difference between the modulated and un-modulated peaks is approximately 8 dB. With the bandwidth of the fundamental at 2% or 200 kHz, the bandwidth at the 3rd harmonic will be 600 kHz.

Figure 9. 3rd Harmonic of the 10 MHz clock

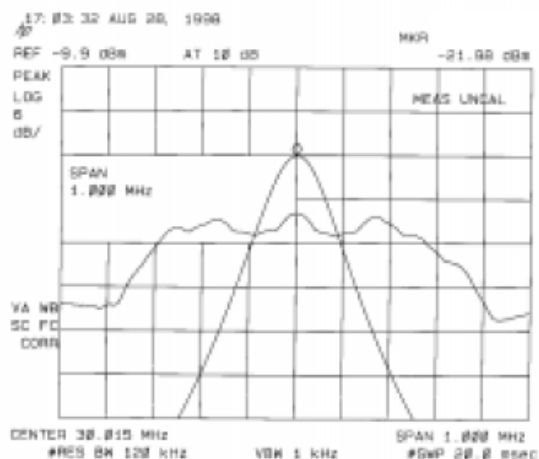

Not Recommended for New Designs

Modulation Rate

The CYIFS741 moves from max to min frequencies of its bandwidth at a pre-determined rate and profile. The modulation frequency is determined by the input frequency and the range that is selected. The CYIFS741 has four input frequency operating ranges, 4–8 MHz, 8–16 MHz, 16–40 MHz and 40–68 MHz. The modulation rate is determined by a divider that results in 1/60, 1/120, 1/240 and 1/480 of the input frequency in each range, respectively. Refer to the [Table 3 on page 9](#).

Figure 10. Frequency Modulation Profile

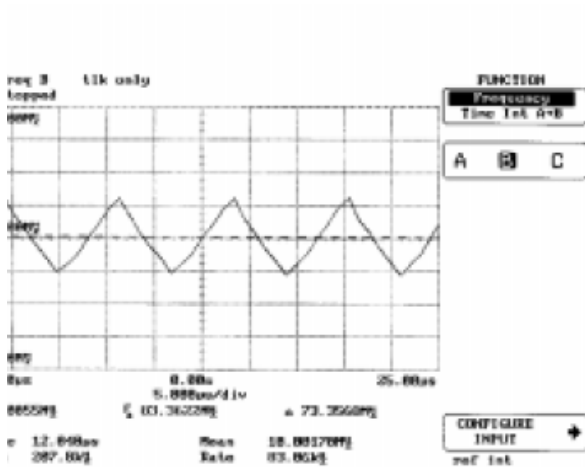

The X_{IN} reference clock determines the modulation frequency but the internal SSCG control logic determines the actual modulation profile. It is very important to note that the Bandwidth of the clock modulation is determined by the values of the loop filter applied to pin 4.

Figure 10 shows the modulation profile of the CYIFS741. This type of test is done with a time domain analyzer. What this shows is the amount of time that the clock spends at any one frequency within its modulation envelope. From this type of picture, the amount of modulation percentage and modulation rate can be determined. This picture shows that the CYIFS741 is modulating 2% around the 10 MHz input and the modulation rate is 83.06 kHz.

Application Notes and Schematics

The schematic diagram shown below is a simple minimum component application example of an CYIFS741 design.

Figure 11. Simple minimum component application example of an CYIFS741 design [5]

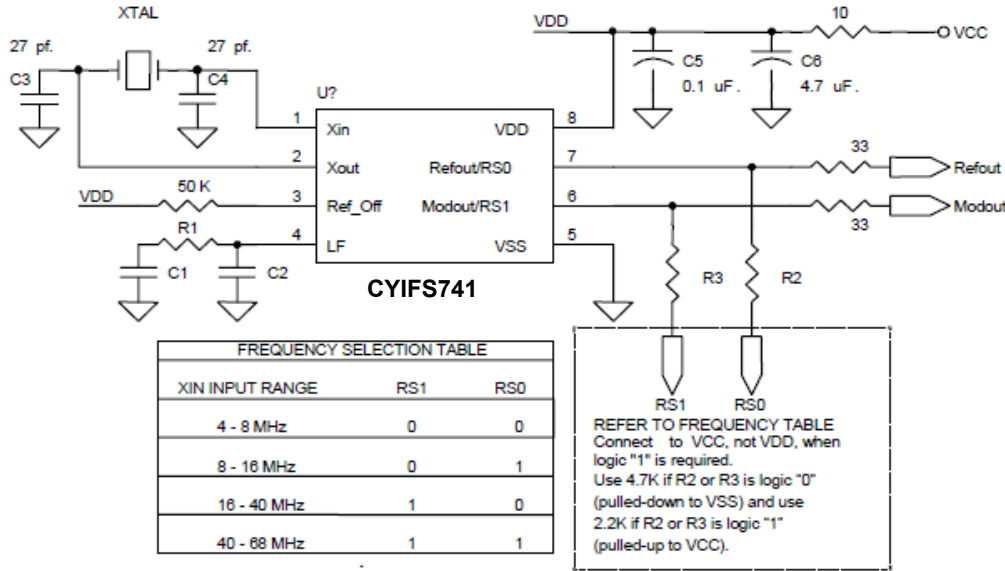
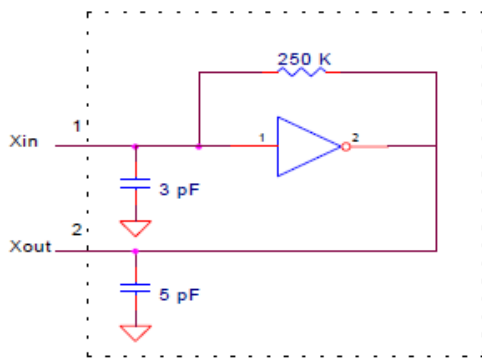

Figure 12 is the equivalent internal oscillator circuit used in the CYIFS741.

Figure 12. Equivalent oscillator circuit used in the CYIFS741



Calculating dB Reduction

The dB reduction for a given frequency and spread can be calculated using a simple formula. This formula is only helpful in determining a relative dB reduction for a given application. This formula assumes an ideal clock with 50% duty cycle and therefore only predicts the EMI reduction of odd harmonics. Other circumstances such as non-ideal clock and noise will affect the actual dB reduction. The formula is as follows;

$$dB = 6.5 + 9(\text{Log}_{10}(F)) + 9(\text{Log}_{10}(P))$$

Where; F = Frequency in MHz, P = total % spread (2.5% = 0.025)

Using a 50 MHz clock with a 2.5% spread, the theoretical dB reduction would be;

$$dB @ 50 \text{ MHz (Fund)} = 6.5 + 15.29 - 14.42 = 7.37$$

$$dB @ 150 \text{ MHz (3}^{rd}\text{)} = 6.5 + 19.58 - 14.42 = 11.66$$

$$dB @ 550 \text{ MHz (11}^{th}\text{)} = 6.5 + 24.66 - 14.42 = 16.74$$

Note

5. C3 and C4 values assume a first order crystal with $C_L = 17 \text{ pF}$.

Not Recommended for New Designs

Absolute Maximum Ratings

Item	Symbol	Min	Max	Units
Operating Voltage	V_{DD}	3.0	6.0	VDC
Input, relative to V_{SS}	V_{IRVSS}	-0.3	$V_{DD} + 0.3$	VDC
Output, relative to V_{SS}	V_{ORVSS}	-0.3	$V_{DD} + 0.3$	VDC
Temperature, Operating	T_{OP}	0	+70	°C
Temperature, Storage	T_{ST}	-65	+150	°C
ESD protection JEDEC standard JS-001-2012	ESD_{HBM}	1300	-	V

Electrical Characteristics

Characteristic	Symbol	Min	Typ	Max	Units
Input Low Voltage	V_{IL}	-	-	0.8	VDC
Input High Voltage	V_{IH}	2.0	-	-	VDC
Input Low Current	I_{IL}	-	-	100	μA
Input High Current	I_{IH}	-	-	100	μA
Output Low Voltage $I_{OL} = 8\text{ mA}$, $V_{DD} = 5\text{ V}$	V_{OL}	-	-	0.4	VDC
Output High Voltage $I_{OH} = 8\text{ mA}$, $V_{DD} = 5\text{ V}$	V_{OH}	$V_{DD} - 1.0$	-	-	VDC
Output Low Voltage $I_{OL} = 5\text{ mA}$, $V_{DD} = 3.3\text{ V}$	V_{OL}	-	-	0.4	VDC
Output High Voltage $I_{OH} = 3\text{ mA}$, $V_{DD} = 3.3\text{ V}$	V_{OH}	2.4	-	-	VDC
Input Capacitance (Pin 1)	C_{IN1}	-	3	4	pF
Output Capacitance (Pin 2)	C_{IN2}	-	5	6	pF
Tri-State Leakage Current (Pin 7)	I_{OZ}	-	-	5.0	μA
5 Volt Dynamic Supply Current (Operating mode)	I_{DD}	-	14	17	mA
3.3 Volt Dynamic Supply Current (Operating mode)	I_{DD}	-	6.3	7.5	mA
Short Circuit Current (Refout or Modout)	I_{SC}	-	-	25	mA
Test measurements performed at $V_{DD} = 3.3\text{ V}$ and $5.0\text{ V} \pm 10\%$, $X_{IN} = 30\text{ MHz}$, $T_A = 0\text{ °C}$ to 70 °C					

Not Recommended for New Designs

Timing Characteristics

Characteristic	Symbol	Min	Typ	Max	Units
Output Rise Time Measured at 10%–90% @ 5 VDC	t _{TLH}	4.5	5.1	5.7	ns
Output Fall Time Measured at 10%–90% @ 5 VDC	t _{THL}	4.0	4.3	4.7	ns
Output Rise Time Measured at 0.8 V–2.0 V @ 5 VDC	t _{TLH}	850	900	975	ps
Output Fall Time Measured at 0.8 V–2.0 V @ 5 VDC	t _{THL}	1.3	1.4	1.5	ns
Output Rise Time Measured at 10%–90% @ 3.3 VDC	t _{TLH}	5.0	5.3	5.9	ns
Output Fall Time Measured at 10%–90% @ 3.3 VDC	t _{THL}	4.8	5.1	5.4	ns
Output Rise Time Measured at 0.8 V–2.0 V @ 3.3 VDC	t _{TLH}	1.8	1.9	2.0	ns
Output Fall Time Measured at 0.8 V–2.0 V @ 3.3 VDC	t _{THL}	2.0	2.2	2.4	ns
Output Duty Cycle	T _{symF1}	45	50	55	%
Peak-to Peak Jitter One Sigma	t _{j1s}	–	150	250	ps

Measurements performed at V_{DD} = 3.3 V and 5.0 V ± 10%, T_A = 0 °C to 70 °C, C_L = 15 pF, X_{IN} = 30 MHz.

Ordering Information

Ordering Code	Part and Package Type	Operating Range
CYIFS741BSXB	8-pin SOIC	Commercial, 0 °C to 70 °C
CYIFS741BSXBT	8-pin SOIC, Tape and Reel	Commercial, 0 °C to 70 °C

Ordering Code Definitions

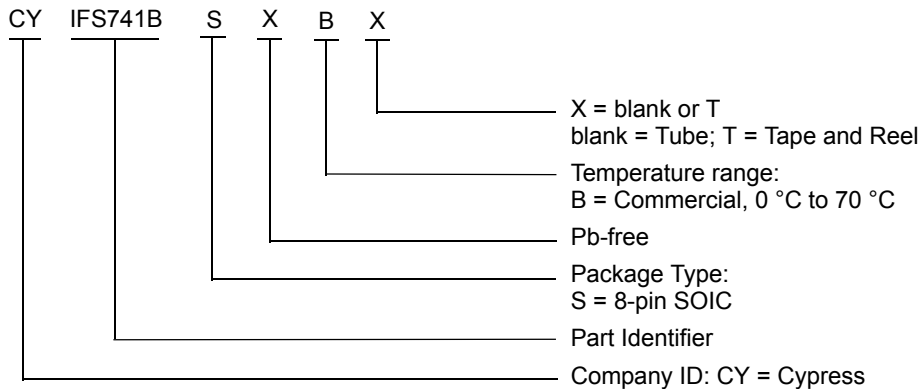

Not Recommended for New Designs

Package Diagram

Figure 13. 8-pin SOIC 150 Mils S08.15/SZ08.15 Package Outline, 51-85066

1. DIMENSIONS IN INCHES[MM] MIN. MAX.
2. PIN 1 ID IS OPTIONAL, ROUND ON SINGLE LEADFRAME RECTANGULAR ON MATRIX LEADFRAME
3. REFERENCE JEDEC MS-012
4. PACKAGE WEIGHT 0.07gms

PART #	
S08.15	STANDARD PKG
SZ08.15	LEAD FREE PKG
SW8.15	LEAD FREE PKG

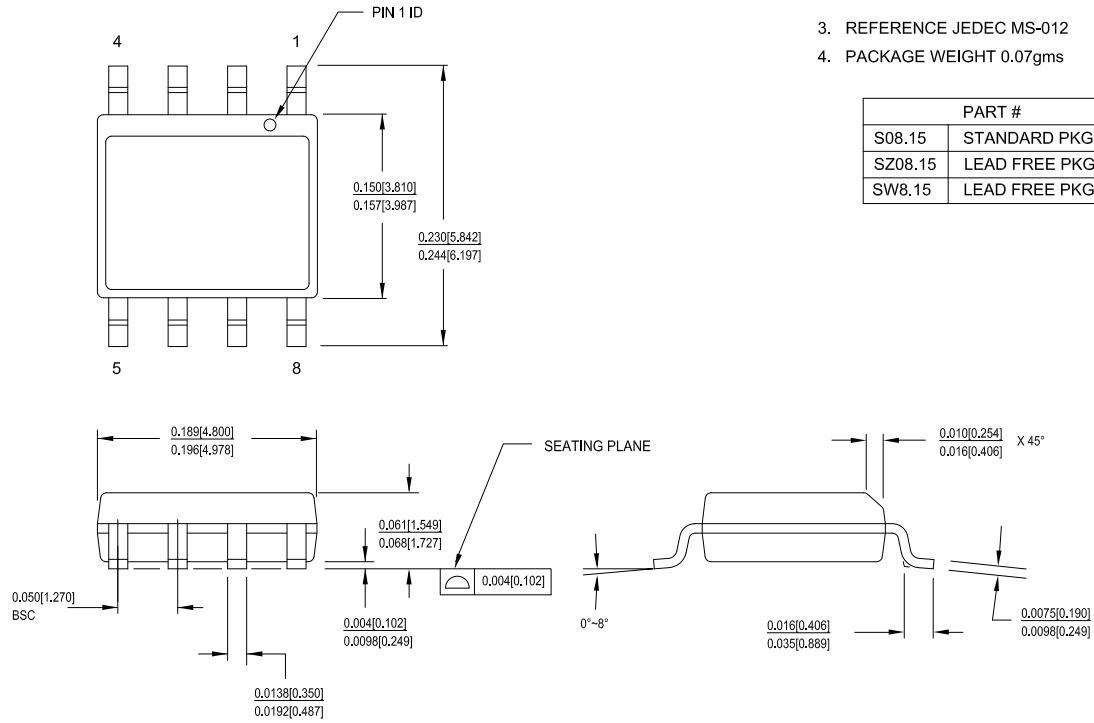

51-85066 *F

Not Recommended for New Designs

Acronyms

Acronym	Description
CMOS	Complementary Metal Oxide Semiconductor
DDS	Direct Digital Synthesis
EMI	Electromagnetic Interference
IC	Integrated Circuit
I/O	Input/Output
LAN	Local Area Network
LCD	Liquid Crystal Display
LF	Loop Filter
PCB	Printed Circuit Board
PLL	Phase Locked Loop
SOIC	Small-Outline Integrated Circuit
TTL	Transistor-Transistor Logic
WAN	Wide Area Network

Document Conventions

Units of Measure

Symbol	Unit of Measure
°C	degree Celsius
dB	decibel
kHz	kilohertz
kΩ	kilohm
MHz	megahertz
μA	microampere
mA	milliampere
mW	milliwatt
ns	nanosecond
%	percent
pF	picofarad
s	second
V	volt

Not Recommended for New Designs

Document History Page

Document Title: CYIFS741, Low EMI Spread Spectrum Clock Document Number: 001-73430				
Rev.	ECN No.	Issue Date	Orig. of Change	Description of Change
**	3403637	10/12/2011	PURU	New data sheet.
*A	4581408	11/27/2014	XHT	<p>Updated Absolute Maximum Ratings: Added ESD_{HBM} parameter and its details.</p> <p>Updated Package Diagram: spec 51-85066 – Changed revision from *E to *F.</p> <p>Added watermark “Not Recommended for New Designs”.</p> <p>Updated to new template.</p> <p>Completing Sunset Review.</p>

Not Recommended for New Designs

Sales, Solutions, and Legal Information

Worldwide Sales and Design Support

Cypress maintains a worldwide network of offices, solution centers, manufacturer's representatives, and distributors. To find the office closest to you, visit us at [Cypress Locations](#).

Products

Automotive	cypress.com/go/automotive
Clocks & Buffers	cypress.com/go/clocks
Interface	cypress.com/go/interface
Lighting & Power Control	cypress.com/go/powerpsoc cypress.com/go/plc
Memory	cypress.com/go/memory
PSoC	cypress.com/go/psoc
Touch Sensing	cypress.com/go/touch
USB Controllers	cypress.com/go/USB
Wireless/RF	cypress.com/go/wireless

PSoC[®] Solutions

[psoc.cypress.com/solutions](#)
[PSoC 1](#) | [PSoC 3](#) | [PSoC 4](#) | [PSoC 5LP](#)

Cypress Developer Community

[Community](#) | [Forums](#) | [Blogs](#) | [Video](#) | [Training](#)

Technical Support

[cypress.com/go/support](#)

Not Recommended for New Designs

© Cypress Semiconductor Corporation, 2011-2014. The information contained herein is subject to change without notice. Cypress Semiconductor Corporation assumes no responsibility for the use of any circuitry other than circuitry embodied in a Cypress product. Nor does it convey or imply any license under patent or other rights. Cypress products are not warranted nor intended to be used for medical, life support, life saving, critical control or safety applications, unless pursuant to an express written agreement with Cypress. Furthermore, Cypress does not authorize its products for use as critical components in life-support systems where a malfunction or failure may reasonably be expected to result in significant injury to the user. The inclusion of Cypress products in life-support systems application implies that the manufacturer assumes all risk of such use and in doing so indemnifies Cypress against all charges.

Any Source Code (software and/or firmware) is owned by Cypress Semiconductor Corporation (Cypress) and is protected by and subject to worldwide patent protection (United States and foreign), United States copyright laws and international treaty provisions. Cypress hereby grants to licensee a personal, non-exclusive, non-transferable license to copy, use, modify, create derivative works of, and compile the Cypress Source Code and derivative works for the sole purpose of creating custom software and or firmware in support of licensee product to be used only in conjunction with a Cypress integrated circuit as specified in the applicable agreement. Any reproduction, modification, translation, compilation, or representation of this Source Code except as specified above is prohibited without the express written permission of Cypress.

Disclaimer: CYPRESS MAKES NO WARRANTY OF ANY KIND, EXPRESS OR IMPLIED, WITH REGARD TO THIS MATERIAL, INCLUDING, BUT NOT LIMITED TO, THE IMPLIED WARRANTIES OF MERCHANTABILITY AND FITNESS FOR A PARTICULAR PURPOSE. Cypress reserves the right to make changes without further notice to the materials described herein. Cypress does not assume any liability arising out of the application or use of any product or circuit described herein. Cypress does not authorize its products for use as critical components in life-support systems where a malfunction or failure may reasonably be expected to result in significant injury to the user. The inclusion of Cypress' product in a life-support systems application implies that the manufacturer assumes all risk of such use and in doing so indemnifies Cypress against all charges.

Use may be limited by and subject to the applicable Cypress software license agreement.