

4-Mbit (128 K × 36) Pipelined Sync SRAM

Features

- Fully registered inputs and outputs for pipelined operation
- 128 K × 36 common I/O architecture
- 3.3 V core power supply (V_{DD})
- 2.5- / 3.3-V I/O power supply (V_{DDQ})
- Fast clock to output times: 2.6 ns (for 250 MHz device)
- User selectable burst counter supporting Intel Pentium interleaved or linear burst sequences
- Separate processor and controller address strobes
- Synchronous self timed writes
- Asynchronous output enable
- Offered in Pb-free 100-pin TQFP, Pb-free 119-ball BGA package
- “ZZ” sleep mode option and stop clock option
- Available in commercial and industrial temperature range

Functional Description

The CY7C1347G is a 3.3 V, 128 K × 36 synchronous pipelined SRAM designed to support zero-wait-state secondary cache with minimal glue logic. CY7C1347G I/O pins can operate at either the 2.5 V or the 3.3 V level. The I/O pins are 3.3 V tolerant when $V_{DDQ} = 2.5$ V. All synchronous inputs pass through input registers controlled by the rising edge of the clock. All data outputs pass through output registers controlled by the rising edge of the clock. Maximum access delay from the clock rise is 2.6 ns (250 MHz device). CY7C1347G supports either the interleaved burst sequence used by the Intel Pentium processor or a linear burst sequence used by processors such as the PowerPC. The burst sequence is selected through the MODE pin. Accesses can be initiated by asserting either the address strobe from processor (\overline{ADSP}) or the address strobe from controller (\overline{ADSC}) at clock rise. Address advancement through the burst sequence is controlled by the ADV input. A 2-bit on-chip wraparound burst counter captures the first address in a burst sequence and automatically increments the address for the rest of the burst access.

Byte write operations are qualified with the four Byte Write Select ($BW_{[A:D]}$) inputs. A global write enable (\overline{GW}) overrides all byte write inputs and writes data to all four bytes. All writes are conducted with on-chip synchronous self timed write circuitry.

Three synchronous chip Selects ($\overline{CE}_1, \overline{CE}_2, \overline{CE}_3$) and an asynchronous output enable (\overline{OE}) provide for easy bank selection and output tristate control. To provide proper data during depth expansion, \overline{OE} is masked during the first clock of a read cycle when emerging from a deselected state.

For a complete list of related documentation, click [here](#).

Selection Guide

Description	250 MHz	200 MHz	166 MHz	133 MHz	Unit
Maximum access time	2.6	2.8	3.5	4.0	ns
Maximum operating current	325	265	240	225	mA
Maximum CMOS standby current	40	40	40	40	mA

Errata: For information on silicon errata, see "Errata" on page 24. Details include trigger conditions, devices affected, and proposed workaround.

Logic Block Diagram

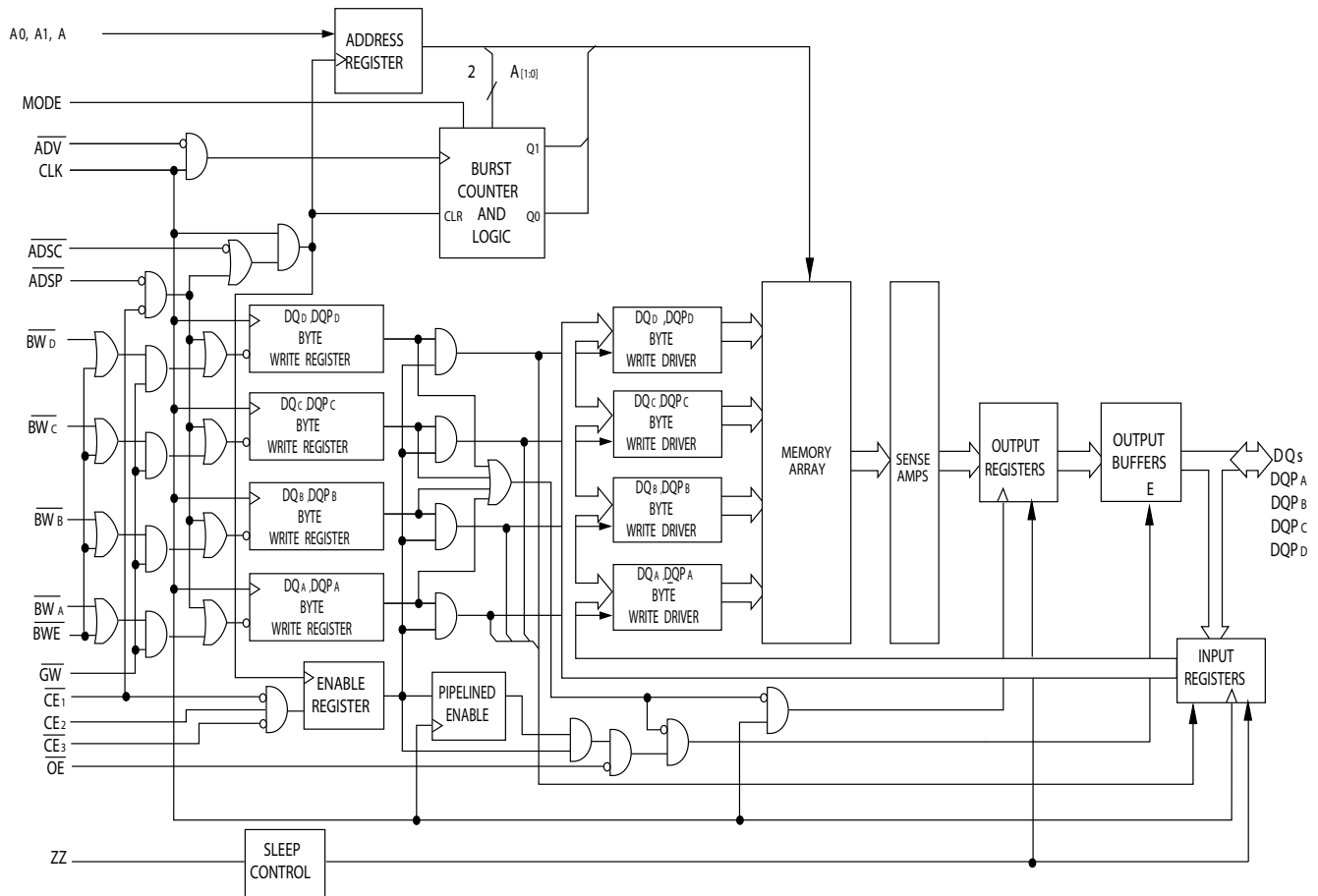

Contents

Pin Configurations	4	Switching Characteristics	15
Pin Definitions	6	Switching Waveforms	16
Functional Overview	8	Ordering Information	20
Single Read Accesses	8	Ordering Code Definitions	20
Single Write Accesses Initiated by ADSP	8	Package Diagrams	21
Single Write Accesses Initiated by ADSC	8	Acronyms	23
Burst Sequences	8	Document Conventions	23
Sleep Mode	9	Units of Measure	23
Interleaved Burst Sequence	9	Errata	24
Linear Burst Sequence	9	Part Numbers Affected	24
ZZ Mode Electrical Characteristics	9	Product Status	24
Truth Table	10	Ram9 Sync ZZ Pin Issues Errata Summary	24
Partial Truth Table for Read/Write	11	Document History Page	25
Maximum Ratings	12	Sales, Solutions, and Legal Information	27
Operating Range	12	Worldwide Sales and Design Support	27
Neutron Soft Error Immunity	12	Products	27
Electrical Characteristics	12	PSoC® Solutions	27
Capacitance	14	Cypress Developer Community	27
Thermal Resistance	14	Technical Support	27
AC Test Loads and Waveforms	14		

Pin Configurations

Figure 1. 100-pin TQFP (14 × 20 × 1.4 mm) pinout [1]

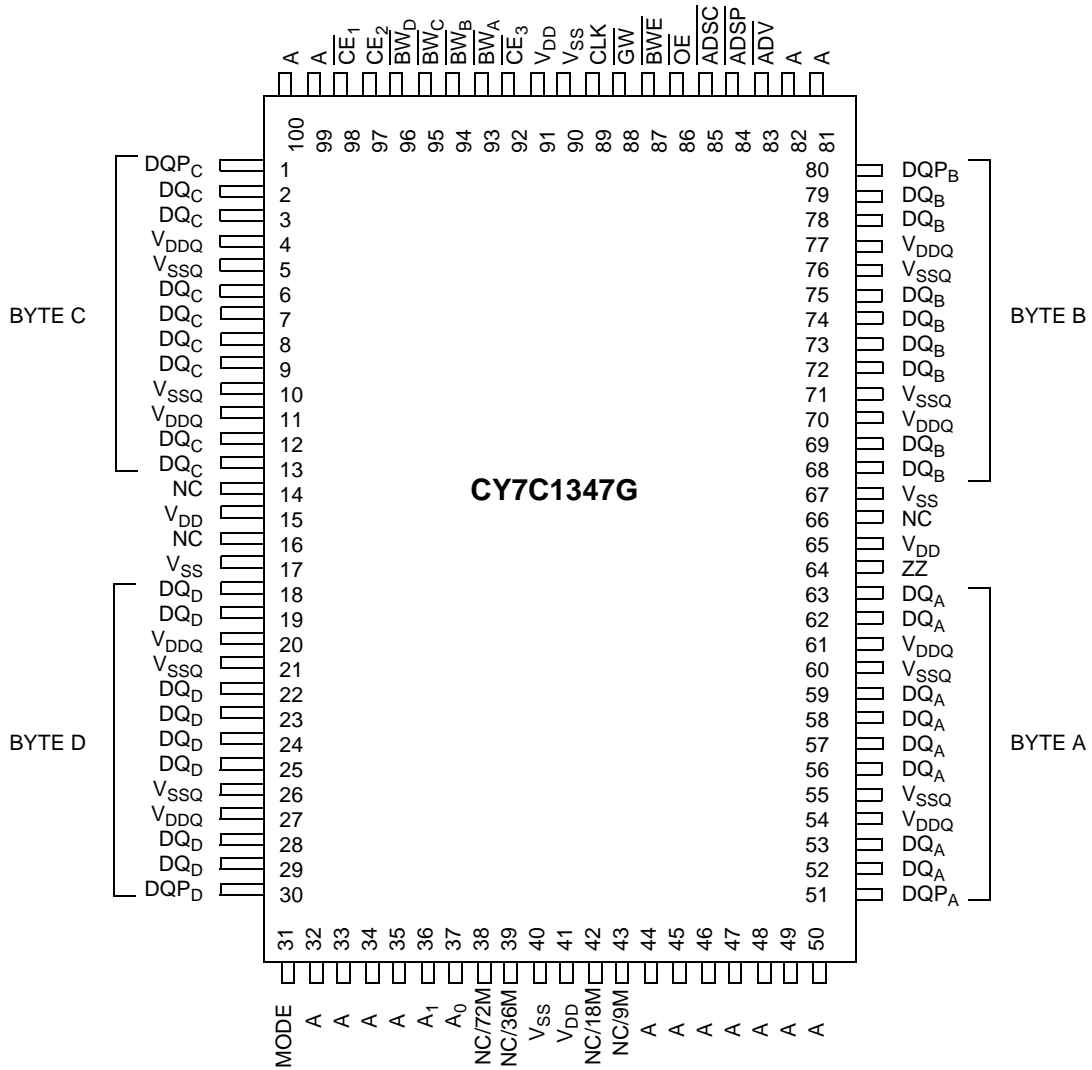

Note

1. Errata: The ZZ pin (Pin 64) needs to be externally connected to ground. For more information, see "Errata" on page 24.

Pin Configurations (continued)

Figure 2. 119-ball BGA (14 × 22 × 2.4 mm) pinout ^[2]

	1	2	3	4	5	6	7
A	V _{DDQ}	A	A	$\overline{\text{ADSP}}$	A	A	V _{DDQ}
B	NC/288 M	CE ₂	A	$\overline{\text{ADSC}}$	A	$\overline{\text{CE}}_3$	NC/576 M
C	NC/144 M	A	A	V _{DD}	A	A	NC/1G
D	DQ _C	DQP _C	V _{SS}	NC	V _{SS}	DQP _B	DQ _B
E	DQ _C	DQ _C	V _{SS}	$\overline{\text{CE}}_1$	V _{SS}	DQ _B	DQ _B
F	V _{DDQ}	DQ _C	V _{SS}	$\overline{\text{OE}}$	V _{SS}	DQ _B	V _{DDQ}
G	DQ _C	DQ _C	$\overline{\text{BW}}_C$	$\overline{\text{ADV}}$	$\overline{\text{BW}}_B$	DQ _B	DQ _B
H	DQ _C	DQ _C	V _{SS}	$\overline{\text{GW}}$	V _{SS}	DQ _B	DQ _B
J	V _{DDQ}	V _{DD}	NC	V _{DD}	NC	V _{DD}	V _{DDQ}
K	DQ _D	DQ _D	V _{SS}	CLK	V _{SS}	DQ _A	DQ _A
L	DQ _D	DQ _D	$\overline{\text{BW}}_D$	NC	$\overline{\text{BW}}_A$	DQ _A	DQ _A
M	V _{DDQ}	DQ _D	V _{SS}	$\overline{\text{BWE}}$	V _{SS}	DQ _A	V _{DDQ}
N	DQ _D	DQ _D	V _{SS}	A1	V _{SS}	DQ _A	DQ _A
P	DQ _D	DQP _D	V _{SS}	A0	V _{SS}	DQP _A	DQ _A
R	NC	A	MODE	V _{DD}	NC	A	NC
T	NC	NC/72M	A	A	A	NC/36M	ZZ
U	V _{DDQ}	NC	NC	NC	NC	NC	V _{DDQ}

Note

2. **Errata:** The ZZ ball (T7) needs to be externally connected to ground. For more information, see "Errata" on page 24.

Pin Definitions

Name	I/O	Description
A ₀ , A ₁ , A	Input-Synchronous	Address Inputs Used to Select One of the 128 K Address Locations. Sampled at the rising edge of the CLK if ADSP or ADSC is active LOW, and \overline{CE}_1 , \overline{CE}_2 , and \overline{CE}_3 are sampled active. A _[1:0] feeds the 2-bit counter.
\overline{BW}_A , \overline{BW}_B , \overline{BW}_C , \overline{BW}_D	Input-Synchronous	Byte Write Select Inputs, Active LOW. Qualified with \overline{BWE} to conduct byte writes to the SRAM. Sampled on the rising edge of CLK.
\overline{GW}	Input-Synchronous	Global Write Enable Input, Active LOW. When asserted LOW on the rising edge of CLK, a global write is conducted (ALL bytes are written, regardless of the values on $\overline{BW}_{[A:D]}$ and \overline{BWE}).
\overline{BWE}	Input-Synchronous	Byte Write Enable Input, Active LOW. Sampled on the rising edge of CLK. This signal must be asserted LOW to conduct a byte write.
CLK	Input-Clock	Clock Input. Used to capture all synchronous inputs to the device. Also used to increment the burst counter when ADV is asserted LOW, during a burst operation.
\overline{CE}_1	Input-Synchronous	Chip Enable 1 Input, Active LOW. Sampled on the rising edge of CLK. Used in conjunction with \overline{CE}_2 and \overline{CE}_3 to select or deselect the device. ADSP is ignored if \overline{CE}_1 is HIGH. \overline{CE}_1 is sampled only when a new external address is loaded.
\overline{CE}_2	Input-Synchronous	Chip Enable 2 Input, Active HIGH. Sampled on the rising edge of CLK. Used in conjunction with \overline{CE}_1 and \overline{CE}_3 to select or deselect the device. \overline{CE}_2 is sampled only when a new external address is loaded.
\overline{CE}_3	Input-Synchronous	Chip Enable 3 Input, Active LOW. Sampled on the rising edge of CLK. Used in conjunction with \overline{CE}_1 and \overline{CE}_2 to select or deselect the device. \overline{CE}_3 is sampled only when a new external address is loaded.
\overline{OE}	Input-Asynchronous	Output Enable, Asynchronous Input, Active LOW. Controls the direction of the I/O pins. When LOW, the I/O pins behave as outputs. When deasserted HIGH, I/O pins are tristated, and act as input data pins. \overline{OE} is masked during the first clock of a read cycle when emerging from a deselected state.
ADV	Input-Synchronous	Advance Input Signal, Sampled on the Rising Edge of CLK. When asserted, it automatically increments the address in a burst cycle.
ADSP	Input-Synchronous	Address Strobe from Processor, Sampled on the Rising Edge of CLK. When asserted LOW, addresses presented to the device are captured in the address registers. A _[1:0] are also loaded into the burst counter. When ADSP and ADSC are both asserted, only ADSP is recognized. ADSP is ignored when \overline{CE}_1 is deasserted HIGH.
ADSC	Input-Synchronous	Address Strobe from Controller, Sampled on the Rising Edge of CLK. When asserted LOW, addresses presented to the device are captured in the address registers. A _[1:0] are also loaded into the burst counter. When ADSP and ADSC are both asserted, only ADSP is recognized.

Pin Definitions (continued)

Name	I/O	Description
ZZ ^[3]	Input-Asynchronous	ZZ “Sleep” Input. This active HIGH input places the device in a non-time-critical “sleep” condition with data integrity preserved. During normal operation, this pin must be LOW or left floating. ZZ pin has an internal pull-down.
DQ _A , DQ _B , DQ _C , DQ _D , DQP _A , DQP _B , DQP _C , DQP _D	I/O-Synchronous	Bidirectional Data I/O Lines. As inputs, they feed into an on-chip data register that is triggered by the rising edge of CLK. As outputs, they deliver the data contained in the memory location specified by the addresses presented during the previous clock rise of the read cycle. The direction of the pins is controlled by OE. When OE is asserted LOW, the pins behave as outputs. When HIGH, DQs and DQPs are placed in a tristate condition.
V _{DD}	Power Supply	Power Supply Inputs to the Core of the Device.
V _{SS}	Ground	Ground for the Core of the Device.
V _{DDQ}	I/O Power Supply	Power Supply for the I/O circuitry.
V _{SSQ}	I/O Ground	Ground for the I/O circuitry.
MODE	Input-Static	Selects Burst Order. When tied to GND selects linear burst sequence. When tied to V _{DDQ} or left floating selects interleaved burst sequence. This is a strap pin and must remain static during device operation. Mode pin has an internal pull-up.
NC, NC/9M, NC/18M, NC/36M, NC/72M, NC/144M, NC/288M, NC/576M, NC/1G	–	No Connects. Not internally connected to the die. NC/9M, NC/18M, NC/36M, NC/72M, NC/144M, NC/288M, NC/576M, and NC/1G are address expansion pins that are not internally connected to the die.

Note

3. **Errata:** The ZZ pin needs to be externally connected to ground. For more information, see "Errata" on page 24.

Functional Overview

All synchronous inputs pass through input registers controlled by the rising edge of the clock. All data outputs pass through output registers controlled by the rising edge of the clock. Maximum access delay from the clock rise (t_{CO}) is 2.6 ns (250 MHz device).

The CY7C1347G supports secondary cache in systems using either a linear or interleaved burst sequence. The linear burst sequence is suited for processors that use a linear burst sequence. The burst order is user selectable, and is determined by sampling the MODE input. Accesses can be initiated with either the Address Strobe from Processor (ADSP) or the Address Strobe from Controller (ADSC). Address advancement through the burst sequence is controlled by the ADV input. A two-bit on-chip wraparound burst counter captures the first address in a burst sequence and automatically increments the address for the rest of the burst access.

Byte write operations are qualified with the Byte Write Enable (BWE) and Byte Write Select ($BW_{[A:D]}$) inputs. A Global Write Enable (GW) overrides all byte write inputs and writes data to all four bytes. All writes are simplified with on-chip synchronous self timed write circuitry.

Three synchronous Chip Selects (\overline{CE}_1 , CE_2 , \overline{CE}_3) and an asynchronous Output Enable (\overline{OE}) provide for easy bank selection and output tristate control. ADSP is ignored if CE_1 is HIGH.

Single Read Accesses

This access is initiated when the following conditions are satisfied at clock rise: (1) ADSP or ADSC is asserted LOW, (2) \overline{CE}_1 , CE_2 , CE_3 are all asserted active, and (3) the write signals (GW, BWE) are all deasserted HIGH. ADSP is ignored if CE_1 is HIGH. The address presented to the address inputs ($A_{[16:0]}$) is stored into the address advancement logic and the Address Register while being presented to the memory core. The corresponding data is allowed to propagate to the input of the Output Registers. At the rising edge of the next clock the data is allowed to propagate through the Output Register and onto the data bus within 2.6 ns (250 MHz device) if \overline{OE} is active LOW. The only exception occurs when the SRAM is emerging from a deselected state to a selected state, its outputs are always tristated during the first cycle of the access. After the first cycle of the access, the outputs are controlled by the \overline{OE} signal. Consecutive single read cycles are supported. After the SRAM is deselected at clock rise by the chip select and either ADSP or ADSC signals, its output tristates immediately.

Single Write Accesses Initiated by ADSP

This access is initiated when both of the following conditions are satisfied at clock rise: (1) ADSP is asserted LOW, and (2) \overline{CE}_1 , CE_2 , CE_3 are all asserted active. The address presented to $A_{[16:0]}$ is loaded into the Address Register and the address advancement logic while being delivered to the RAM core. The write signals (GW, BWE, and $BW_{[A:D]}$) and ADV inputs are ignored during this first cycle.

\overline{ADSP} -triggered write accesses require two clock cycles to complete. If GW is asserted LOW on the second clock rise, the data presented to the DQs and DQPs inputs is written into the corresponding address location in the RAM core. If \overline{GW} is HIGH, then the write operation is controlled by BWE and $BW_{[A:D]}$ signals. The CY7C1347G provides byte write capability that is described in "Partial Truth Table for Read/Write" on page 11. Asserting the Byte Write Enable input (BWE) with the selected Byte Write ($BW_{[A:D]}$) input selectively writes to only the desired bytes.

Bytes not selected during a byte write operation remain unaltered. A synchronous self timed write mechanism is provided to simplify the write operations.

Because the CY7C1347G is a common I/O device, the Output Enable (\overline{OE}) must be deasserted HIGH before presenting data to the DQs and DQPs inputs. Doing so tristates the output drivers. As a safety precaution, DQs and DQPs are automatically tristated whenever a write cycle is detected, regardless of the state of \overline{OE} .

Single Write Accesses Initiated by ADSC

\overline{ADSC} write accesses are initiated when the following conditions are satisfied: (1) ADSC is asserted LOW, (2) ADSP is deasserted HIGH, (3) CE_1 , CE_2 , CE_3 are all asserted active, and (4) the appropriate combination of the write inputs (GW, BWE, and $BW_{[A:D]}$) are asserted active to conduct a write to the desired byte(s). ADSC-triggered write accesses require a single clock cycle to complete. The address presented to $A_{[16:0]}$ is loaded into the address register and the address advancement logic while being delivered to the RAM core. The ADV input is ignored during this cycle. If a global write is conducted, the data presented to the DQs and DQPs is written into the corresponding address location in the RAM core. If a byte write is conducted, only the selected bytes are written. Bytes not selected during a byte write operation remain unaltered. A synchronous self timed write mechanism has been provided to simplify the write operations.

Because the CY7C1347G is a common I/O device, the Output Enable (\overline{OE}) must be deasserted HIGH before presenting data to the DQs and DQPs inputs. Doing so tristates the output drivers. As a safety precaution, DQs and DQPs are automatically tristated whenever a write cycle is detected, regardless of the state of \overline{OE} .

Burst Sequences

The CY7C1347G provides a two-bit wraparound counter, fed by $A_{[1:0]}$, that implements either an interleaved or linear burst sequence. The interleaved burst sequence is designed specifically to support Intel Pentium applications. The linear burst sequence is designed to support processors that follow a linear burst sequence. The burst sequence is user-selectable through the MODE input.

Asserting \overline{ADV} LOW at clock rise automatically increments the burst counter to the next address in the burst sequence. Both read and write burst operations are supported.

Sleep Mode

The ZZ input pin is an asynchronous input. Asserting ZZ places the SRAM in a power conservation “sleep” mode. Two clock cycles are required to enter into or exit from this “sleep” mode. While in this mode, data integrity is guaranteed. Accesses pending when entering the “sleep” mode are not considered valid nor is the completion of the operation guaranteed. The device must be deselected before entering the “sleep” mode. CE₁, CE₂, CE₃, ADSP, and ADSC must remain inactive for the duration of t_{ZZREC} after the ZZ input returns LOW.

Linear Burst Sequence

First Address A _[1:0]	Second Address A _[1:0]	Third Address A _[1:0]	Fourth Address A _[1:0]
00	01	10	11
01	10	11	00
10	11	00	01
11	00	01	10

Interleaved Burst Sequence

First Address A _[1:0]	Second Address A _[1:0]	Third Address A _[1:0]	Fourth Address A _[1:0]
00	01	10	11
01	00	11	10
10	11	00	01
11	10	01	00

ZZ Mode Electrical Characteristics

Parameter	Description	Test Conditions	Min	Max	Unit
I _{DDZZ}	Snooze mode standby current	ZZ ≥ V _{DD} – 0.2 V	–	40	mA
t _{ZZS}	Device operation to ZZ	ZZ ≥ V _{DD} – 0.2 V	–	2t _{CYC}	ns
t _{ZZREC}	ZZ recovery time	ZZ ≤ 0.2 V	2t _{CYC}	–	ns
t _{ZZI}	ZZ Active to snooze current	This parameter is sampled	–	2t _{CYC}	ns
t _{RZZI}	ZZ Inactive to exit snooze current	This parameter is sampled	0	–	ns

Truth Table

The truth table for part number CY7C1347G follow.

Next Cycle ^[4, 5, 6, 7, 8]	Add. Used	CE ₁	CE ₂	CE ₃	ZZ	ADSP	ADSC	ADV	WRITE	OE	CLK	DQ
Deselect cycle, power-down	None	H	X	X	L	X	L	X	X	X	L-H	Tristate
Deselect cycle, power-down	None	L	L	X	L	L	X	X	X	X	L-H	Tristate
Deselect cycle, power-down	None	L	X	H	L	L	X	X	X	X	L-H	Tristate
Deselect cycle, power-down	None	L	L	X	L	H	L	X	X	X	L-H	Tristate
Deselect cycle, power-down	None	L	X	H	L	H	L	X	X	X	L-H	Tristate
Snooze mode, power-down	None	X	X	X	H	X	X	X	X	X	X	Tristate
Read Cycle, Begin Burst	External	L	H	L	L	L	X	X	X	L	L-H	Q
Read Cycle, Begin Burst	External	L	H	L	L	L	X	X	X	H	L-H	Tristate
Write Cycle, Begin Burst	External	L	H	L	L	H	L	X	L	X	L-H	D
Read Cycle, Begin Burst	External	L	H	L	L	H	L	X	H	L	L-H	Q
Read Cycle, Begin Burst	External	L	H	L	L	H	L	X	H	H	L-H	Tristate
Read Cycle, Continue Burst	Next	X	X	X	L	H	H	L	H	H	L-H	Tristate
Read Cycle, Continue Burst	Next	X	X	X	L	H	H	L	H	L	L-H	Q
Read Cycle, Continue Burst	Next	H	X	X	L	X	H	L	H	L	L-H	Q
Read Cycle, Continue Burst	Next	H	X	X	L	X	H	L	H	H	L-H	Tristate
Write cycle, continue burst	Next	X	X	X	L	H	H	L	L	X	L-H	D
Write cycle, continue burst	Next	H	X	X	L	X	H	L	L	X	L-H	D
Read cycle, suspend burst	Current	X	X	X	L	H	H	H	H	L	L-H	Q
Read cycle, suspend burst	Current	X	X	X	L	H	H	H	H	H	L-H	Tristate
Read cycle, suspend burst	Current	H	X	X	L	X	H	H	H	L	L-H	Q
Read cycle, suspend burst	Current	H	X	X	L	X	H	H	H	H	L-H	Tristate
Write cycle, suspend burst	Current	X	X	X	L	H	H	H	L	X	L-H	D
Write cycle, suspend burst	Current	H	X	X	L	X	H	H	L	X	L-H	D

Notes

- X = "Do not Care." H = Logic HIGH, L = Logic LOW.
- $\overline{WRITE} = L$ when any one or more Byte Write Enable signals (\overline{BW}_A , \overline{BW}_B , \overline{BW}_C , \overline{BW}_D) and $\overline{BWE} = L$ or $\overline{GW} = L$. $\overline{WRITE} = H$ when all Byte Write Enable signals (\overline{BW}_A , \overline{BW}_B , \overline{BW}_C , \overline{BW}_D), \overline{BWE} , $\overline{GW} = H$.
- The DQ pins are controlled by the current cycle and the \overline{OE} signal. \overline{OE} is asynchronous and is not sampled with the clock.
- The SRAM always initiates a read cycle when \overline{ADSP} is asserted, regardless of the state of \overline{GW} , \overline{BWE} , or $\overline{BW}_{[A,D]}$. Writes may occur only on subsequent clocks after the \overline{ADSP} or with the assertion of \overline{ADSC} . As a result, \overline{OE} must be driven HIGH before the start of the write cycle to allow the outputs to tristate. \overline{OE} is a do not care for the remainder of the write cycle.
- \overline{OE} is asynchronous and is not sampled with the clock rise. It is masked internally during write cycles. During a read cycle all data bits are tristate when \overline{OE} is inactive or when the device is deselected, and all data bits behave as output when \overline{OE} is active (LOW).

Partial Truth Table for Read/Write

The partial truth table for read/write for part number CY7C1347G follow.

Function ^[9, 10]	\overline{GW}	\overline{BWE}	\overline{BW}_D	\overline{BW}_C	\overline{BW}_B	\overline{BW}_A
Read	H	H	X	X	X	X
Read	H	L	H	H	H	H
Write byte A – DQ _A	H	L	H	H	H	L
Write byte B – DQ _B	H	L	H	H	L	H
Write bytes B, A	H	L	H	H	L	L
Write byte C – DQ _C	H	L	H	L	H	H
Write bytes C, A	H	L	H	L	H	L
Write bytes C, B	H	L	H	L	L	H
Write bytes C, B, A	H	L	H	L	L	L
Write byte D – DQ _D	H	L	L	H	H	H
Write bytes D, A	H	L	L	H	H	L
Write bytes D, B	H	L	L	H	L	H
Write bytes D, B, A	H	L	L	H	L	L
Write bytes D, C	H	L	L	L	H	H
Write bytes D, C, A	H	L	L	L	H	L
Write bytes D, C, B	H	L	L	L	L	H
Write all bytes	H	L	L	L	L	L
Write all bytes	L	X	X	X	X	X

Notes

9. X = "Do not Care." H = Logic HIGH, L = Logic LOW.

10. This table is only a partial listing of the byte write combinations. Any combination of \overline{BW}_x is valid. Appropriate write is based on which byte write is active.

Maximum Ratings

Exceeding maximum ratings may shorten the useful life of the device. User guidelines are not tested.

Storage temperature	-65 °C to +150 °C
Ambient temperature with power applied	-55 °C to +125 °C
Supply voltage on V _{DD} relative to GND	-0.5 V to +4.6 V
Supply voltage on V _{DDQ} relative to GND	-0.5 V to +V _{DD}
DC voltage applied to outputs in high Z State	-0.5 V to V _{DD} + 0.5 V
DC input voltage	-0.5 V to V _{DD} + 0.5 V
Current into outputs (LOW)	20 mA
Static discharge voltage (MIL-STD-883, Method 3015)	> 2001 V
Latch-up Current	> 200 mA

Operating Range

Range	Ambient Temperature	V _{DD}	V _{DDQ}
Commercial	0 °C to +70 °C	3.3 V – 5% / +10%	2.5 V – 5% to V _{DD}
Industrial	-40 °C to +85 °C		

Neutron Soft Error Immunity

Parameter	Description	Test Conditions	Typ	Max*	Unit
LSBU	Logical single-bit upsets	25 °C	361	394	FIT/Mb
LMBU	Logical multi-bit upsets	25 °C	0	0.01	FIT/Mb
SEL	Single event latch-up	85 °C	0	0.1	FIT/Dev

* No LMBU or SEL events occurred during testing; this column represents a statistical χ^2 , 95% confidence limit calculation. For more details refer to Application Note, [Accelerated Neutron SER Testing and Calculation of Terrestrial Failure Rates – AN54908](#).

Electrical Characteristics

Over the Operating Range

Parameter ^[11, 12]	Description	Test Conditions	Min	Max	Unit
V _{DD}	Power supply voltage		3.135	3.6	V
V _{DDQ}	I/O supply voltage		2.375	V _{DD}	V
V _{OH}	Output HIGH voltage	For 3.3 V I/O, I _{OH} = -4.0 mA	2.4	-	V
		For 2.5 V I/O, I _{OH} = -1.0 mA	2.0	-	V
V _{OL}	Output LOW voltage	For 3.3 V I/O, I _{OL} = 8.0 mA	-	0.4	V
		For 2.5 V I/O, I _{OL} = 1.0 mA	-	0.4	V
V _{IH}	Input HIGH voltage ^[11]	For 3.3 V I/O	2.0	V _{DD} + 0.3	V
		For 2.5 V I/O	1.7	V _{DD} + 0.3	V
V _{IL}	Input LOW voltage ^[11]	For 3.3 V I/O	-0.3	0.8	V
		For 2.5 V I/O	-0.3	0.7	V
I _X	Input leakage current except ZZ and MODE	GND ≤ V _I ≤ V _{DDQ}	-5	5	μA
	Input current of MODE	Input = V _{SS}	-30	-	μA
		Input = V _{DD}	-	5	μA
	Input current of ZZ	Input = V _{SS}	-5	-	μA
Input = V _{DD}		-	30	μA	
I _{OZ}	Output leakage current	GND ≤ V _I ≤ V _{DDQ} , output disabled	-5	5	μA

Notes

- Overshoot: V_{IH(AC)} < V_{DD} + 1.5 V (pulse width less than t_{CYC/2}). Undershoot: V_{IL(AC)} > -2 V (pulse width less than t_{CYC/2}).
- t_{power-up}: assumes a linear ramp from 0 V to V_{DD(min)} within 200 ms. During this time V_{IH} < V_{DD} and V_{DDQ} ≤ V_{DD}.

Electrical Characteristics (continued)

Over the Operating Range

Parameter ^[11, 12]	Description	Test Conditions	Min	Max	Unit	
I _{DD}	V _{DD} operating supply current	V _{DD} = Max., I _{OUT} = 0 mA, f = f _{MAX} = 1/t _{CYC}	4 ns cycle, 250 MHz	–	325	mA
			5 ns cycle, 200 MHz	–	265	mA
			6 ns cycle, 166 MHz	–	240	mA
			7.5 ns cycle, 133 MHz	–	225	mA
I _{SB1}	Automatic CE power-down current – TTL inputs	Max. V _{DD} , device deselected, V _{IN} ≥ V _{IH} or V _{IN} ≤ V _{IL} , f = f _{MAX} = 1/t _{CYC}	4 ns cycle, 250 MHz	–	120	mA
			5 ns cycle, 200 MHz	–	110	mA
			6 ns cycle, 166 MHz	–	100	mA
			7.5 ns cycle, 133 MHz	–	90	mA
I _{SB2}	Automatic CE power-down current – CMOS inputs	Max. V _{DD} , device deselected, V _{IN} ≤ 0.3 V or V _{IN} ≥ V _{DDQ} – 0.3 V, f = 0	All speeds	–	40	mA
I _{SB3}	Automatic CE power-down current – CMOS inputs	Max. V _{DD} , device deselected, V _{IN} ≤ 0.3 V or V _{IN} ≥ V _{DDQ} – 0.3 V, f = f _{MAX} = 1/t _{CYC}	4 ns cycle, 250 MHz	–	105	mA
			5 ns cycle, 200 MHz	–	95	mA
			6 ns cycle, 166 MHz	–	85	mA
			7.5 ns cycle, 133 MHz	–	75	mA
I _{SB4}	Automatic CE power-down current – TTL inputs	Max. V _{DD} , device deselected, V _{IN} ≥ V _{IH} or V _{IN} ≤ V _{IL} , f = 0		–	45	mA

Capacitance

Parameter [13]	Description	Test Conditions	100-pin TQFP Max	119-ball BGA Max	Unit
C_{IN}	Input capacitance	$T_A = 25\text{ }^\circ\text{C}$, $f = 1\text{ MHz}$, $V_{DD} = 3.3\text{ V}$, $V_{DDQ} = 3.3\text{ V}$	5	5	pF
C_{CLK}	Clock input capacitance		5	5	pF
C_{IO}	I/O capacitance		5	7	pF

Thermal Resistance

Parameter [13]	Description	Test Conditions	100-pin TQFP Package	119-ball BGA Package	Unit
Θ_{JA}	Thermal resistance (junction to ambient)	Test conditions follow standard test methods and procedures for measuring thermal impedance, per EIA/JESD51.	30.32	34.1	$^\circ\text{C/W}$
Θ_{JC}	Thermal resistance (junction to case)		6.85	14.0	$^\circ\text{C/W}$

AC Test Loads and Waveforms

Figure 3. AC Test Loads and Waveforms

3.3 V I/O Test Load

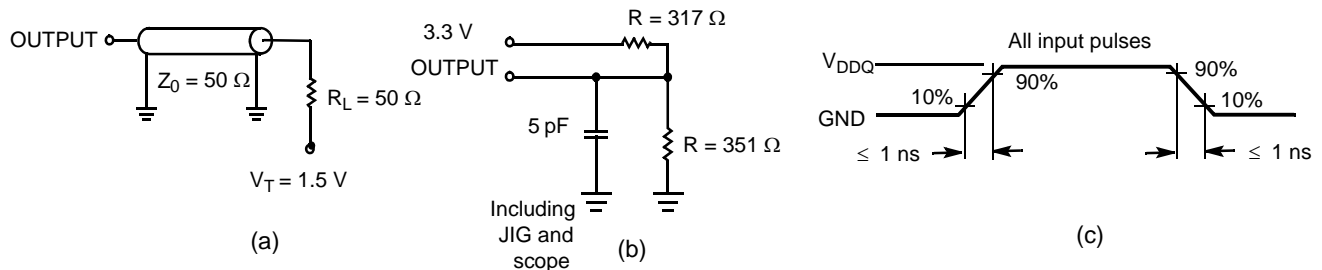

2.5 V I/O Test Load

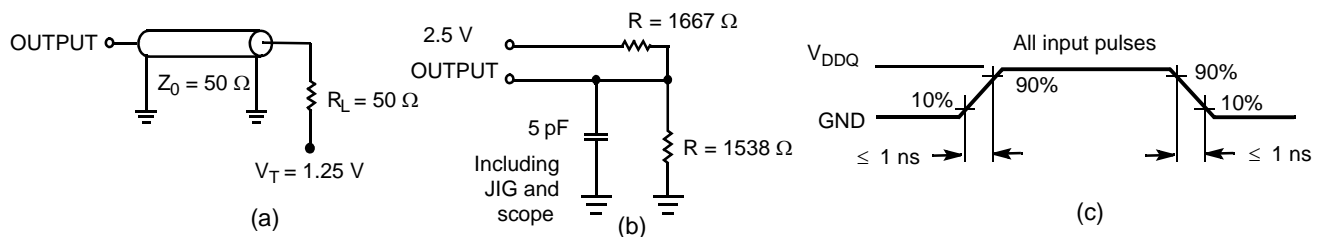

Note

13. Tested initially and after any design or process changes that may affect these parameters.

Switching Characteristics

Over the Operating Range

Parameter ^[14, 15]	Description	-250		-200		-166		-133		Unit
		Min	Max	Min	Max	Min	Max	Min	Max	
t _{POWER}	V _{DD} (typical) to the first access ^[16]	1	–	1	–	1	–	1	–	ms
Clock										
t _{CYC}	Clock cycle time	4.0	–	5.0	–	6.0	–	7.5	–	ns
t _{CH}	Clock HIGH	1.7	–	2.0	–	2.5	–	3.0	–	ns
t _{CL}	Clock LOW	1.7	–	2.0	–	2.5	–	3.0	–	ns
Output Times										
t _{CO}	Data output valid after CLK rise	–	2.6	–	2.8	–	3.5	–	4.0	ns
t _{DOH}	Data output hold after CLK rise	1.0	–	1.0	–	1.5	–	1.5	–	ns
t _{CLZ}	Clock to low Z ^[17, 18, 19]	0	–	0	–	0	–	0	–	ns
t _{CHZ}	Clock to high Z ^[17, 18, 19]	–	2.6	–	2.8	–	3.5	–	4.0	ns
t _{OE\overline{V}}	\overline{OE} LOW to output valid	–	2.6	–	2.8	–	3.5	–	4.5	ns
t _{OE\overline{LZ}}	\overline{OE} LOW to output low Z ^[17, 18, 19]	0	–	0	–	0	–	0	–	ns
t _{OE\overline{HZ}}	\overline{OE} HIGH to output high Z ^[17, 18, 19]	–	2.6	–	2.8	–	3.5	–	4.0	ns
Setup Times										
t _{AS}	Address setup before CLK rise	1.2	–	1.2	–	1.5	–	1.5	–	ns
t _{ADS}	\overline{ADSC} , \overline{ADSP} setup before CLK rise	1.2	–	1.2	–	1.5	–	1.5	–	ns
t _{ADVS}	\overline{ADV} setup before CLK rise	1.2	–	1.2	–	1.5	–	1.5	–	ns
t _{WES}	\overline{GW} , \overline{BWE} , $\overline{BW_X}$ setup before CLK rise	1.2	–	1.2	–	1.5	–	1.5	–	ns
t _{DS}	Data input setup before CLK rise	1.2	–	1.2	–	1.5	–	1.5	–	ns
t _{CES}	Chip enable setup before CLK rise	1.2	–	1.2	–	1.5	–	1.5	–	ns
Hold Times										
t _{AH}	Address hold after CLK rise	0.3	–	0.5	–	0.5	–	0.5	–	ns
t _{ADH}	\overline{ADSP} , \overline{ADSC} hold after CLK rise	0.3	–	0.5	–	0.5	–	0.5	–	ns
t _{ADVH}	\overline{ADV} hold after CLK Rise	0.3	–	0.5	–	0.5	–	0.5	–	ns
t _{WEH}	\overline{GW} , \overline{BWE} , $\overline{BW_X}$ hold after CLK rise	0.3	–	0.5	–	0.5	–	0.5	–	ns
t _{DH}	Data input hold after CLK rise	0.3	–	0.5	–	0.5	–	0.5	–	ns
t _{CEH}	Chip enable hold after CLK rise	0.3	–	0.5	–	0.5	–	0.5	–	ns

Notes

14. Timing references level is 1.5 V when V_{DDQ} = 3.3 V and is 1.25 V when V_{DDQ} = 2.5 V on all datasheets.
15. Test conditions shown in (a) of [Figure 3 on page 14](#) unless otherwise noted.
16. This part has an internal voltage regulator; t_{POWER} is the time that the power must be supplied above V_{DD(min)} initially before a read or write operation can be initiated.
17. t_{CHZ}, t_{CLZ}, t_{OE \overline{LZ}} , and t_{OE \overline{HZ}} are specified with AC test conditions shown in part (b) of [Figure 3 on page 14](#). Transition is measured ±200 mV from steady-state voltage.
18. At any voltage and temperature, t_{OE \overline{HZ}} is less than t_{OE \overline{LZ}} and t_{CHZ} is less than t_{CLZ} to eliminate bus contention between SRAMs when sharing the same data bus. These specifications do not imply a bus contention condition, but reflect parameters guaranteed over worst case user conditions. Device is designed to achieve High Z before Low Z under the same system conditions.
19. This parameter is sampled and not 100% tested.

Switching Waveforms

Figure 4. Read Cycle Timing [20]

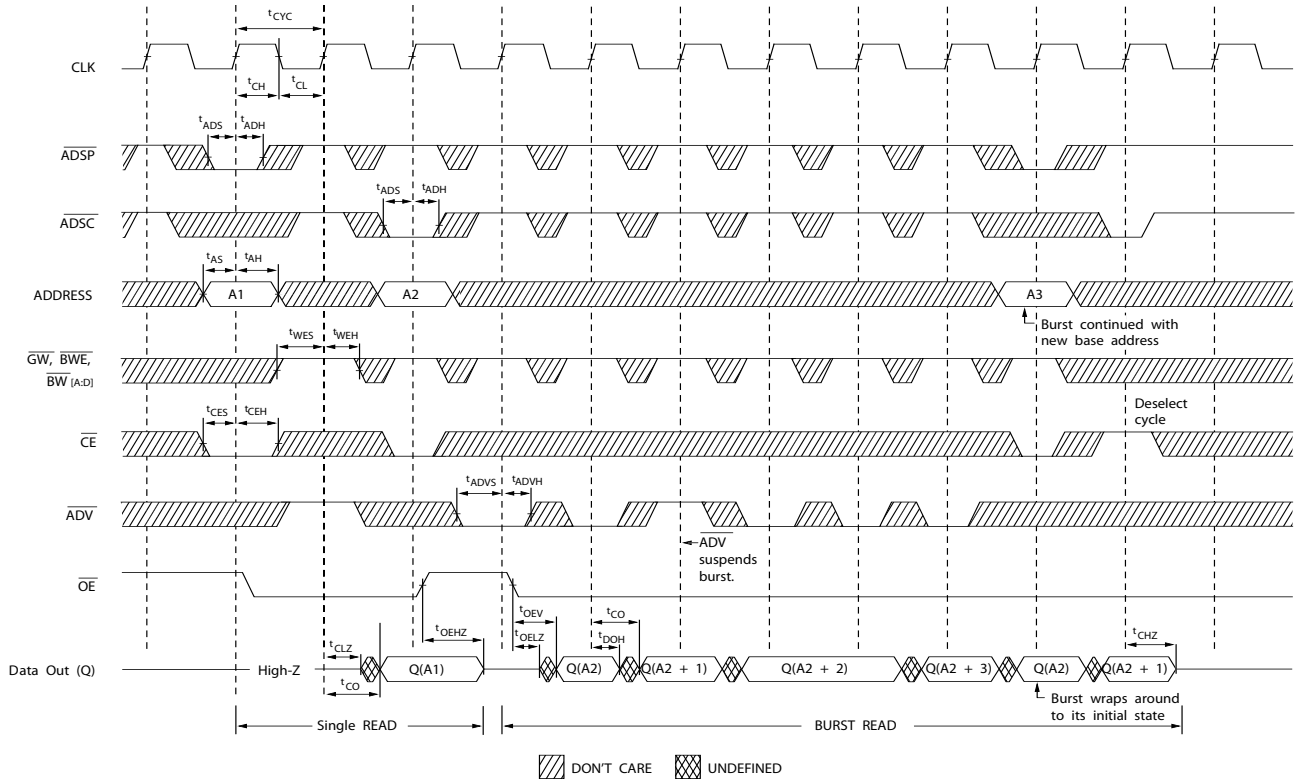

Note

20. In this diagram, when \overline{CE} is LOW, \overline{CE}_1 is LOW, CE_2 is HIGH, and \overline{CE}_3 is LOW. When \overline{CE} is HIGH, \overline{CE}_1 is HIGH, CE_2 is LOW, or \overline{CE}_3 is HIGH.

Switching Waveforms (continued)

Figure 5. Write Cycle Timing [21, 22]

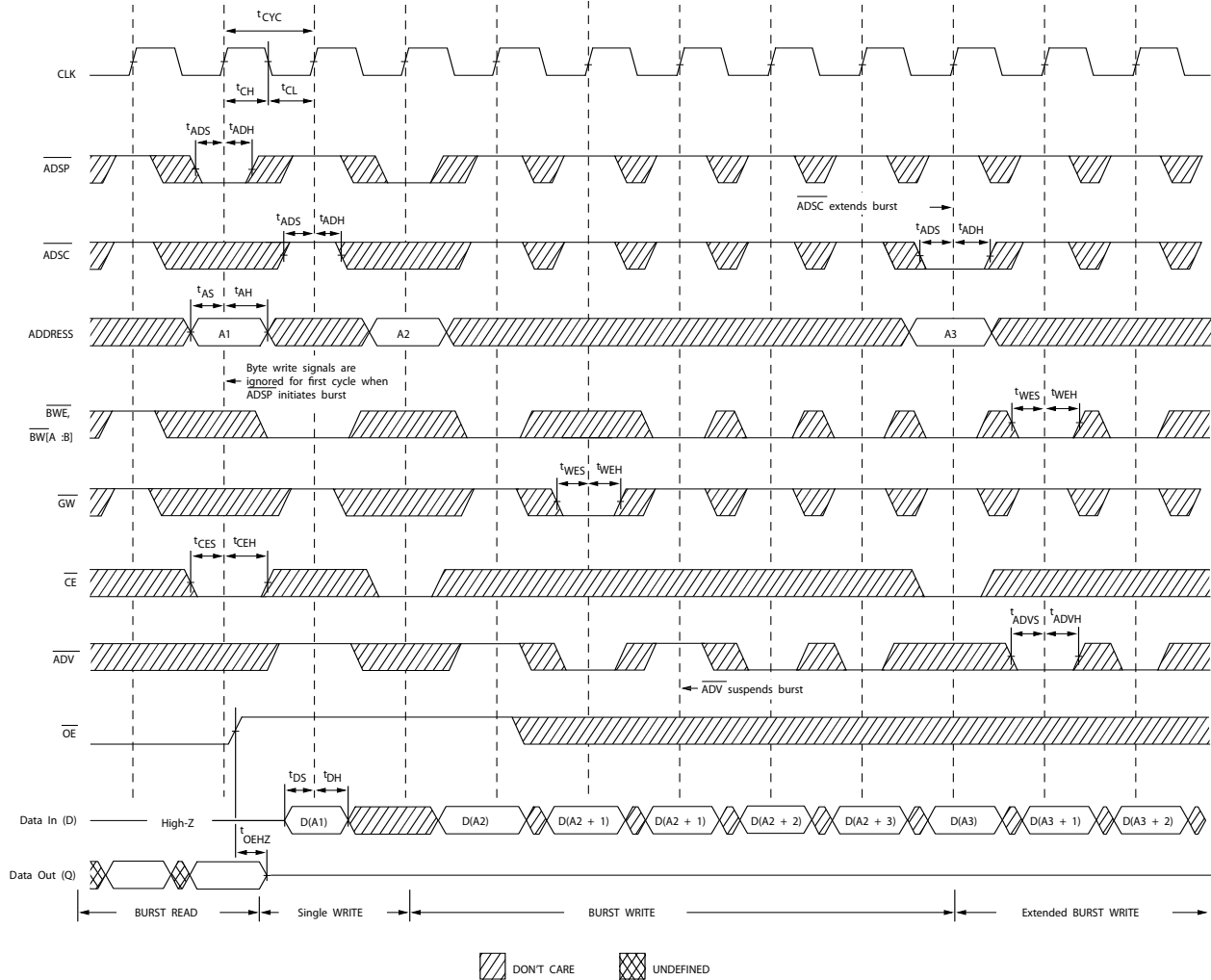

Notes

21. In this diagram, when \overline{CE} is LOW, \overline{CE}_1 is LOW, CE_2 is HIGH, and \overline{CE}_3 is LOW. When \overline{CE} is HIGH, \overline{CE}_1 is HIGH, CE_2 is LOW, or \overline{CE}_3 is HIGH.
22. Full width write can be initiated by either \overline{GW} LOW, or by \overline{GW} HIGH, \overline{BWE} LOW, and \overline{BW}_x LOW.

Switching Waveforms (continued)

Figure 6. Read/Write Cycle Timing [23, 24, 25]

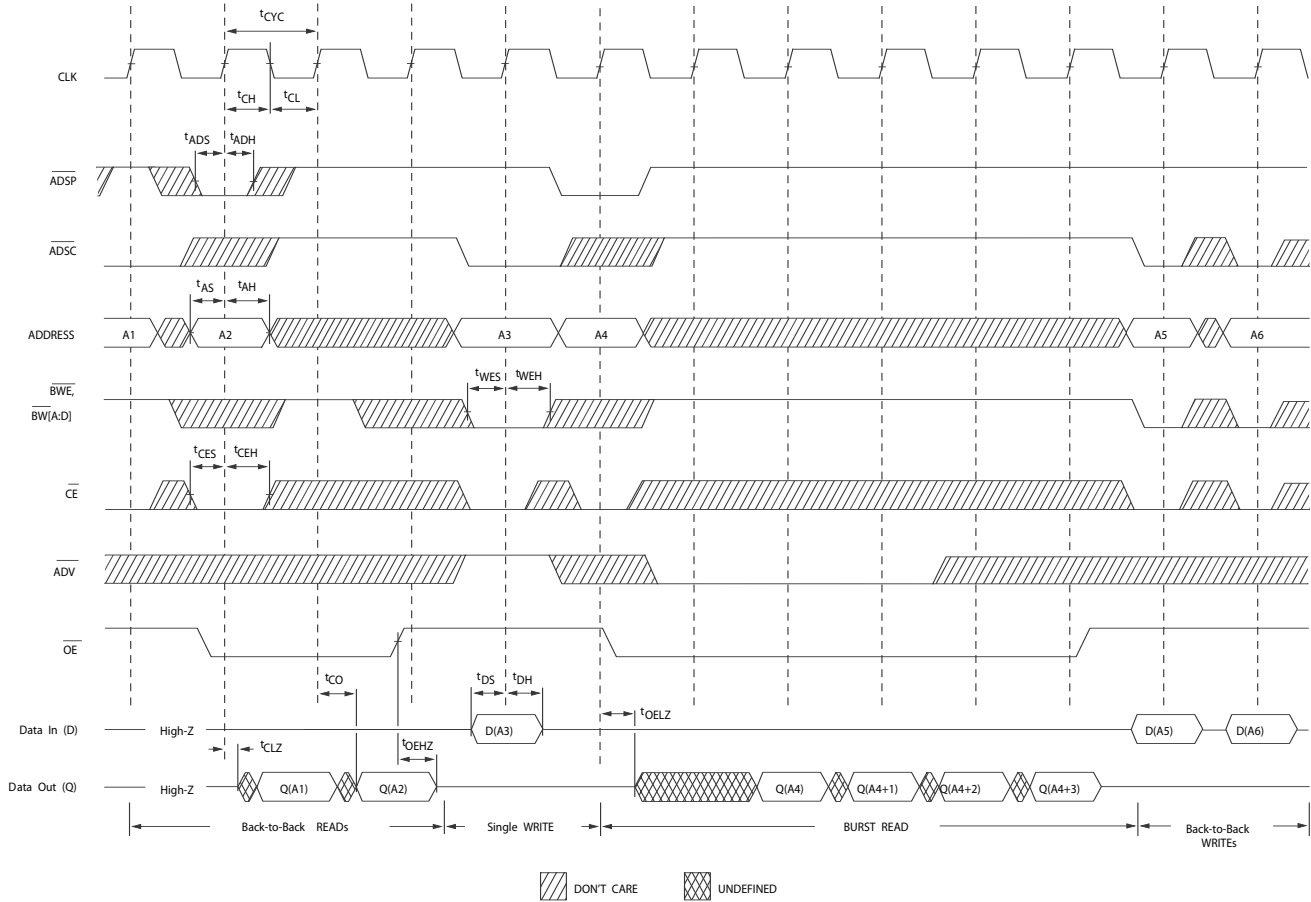

Notes

- 23. In this diagram, when \overline{CE} is LOW, \overline{CE}_1 is LOW, CE_2 is HIGH, and \overline{CE}_3 is LOW. When \overline{CE} is HIGH, \overline{CE}_1 is HIGH, CE_2 is LOW, or \overline{CE}_3 is HIGH.
- 24. The data bus (Q) remains in High Z following a write cycle, unless a new read access is initiated by ADSP or ADSC.
- 25. GW is HIGH.

Switching Waveforms (continued)

Figure 7. ZZ Mode Timing [26, 27]

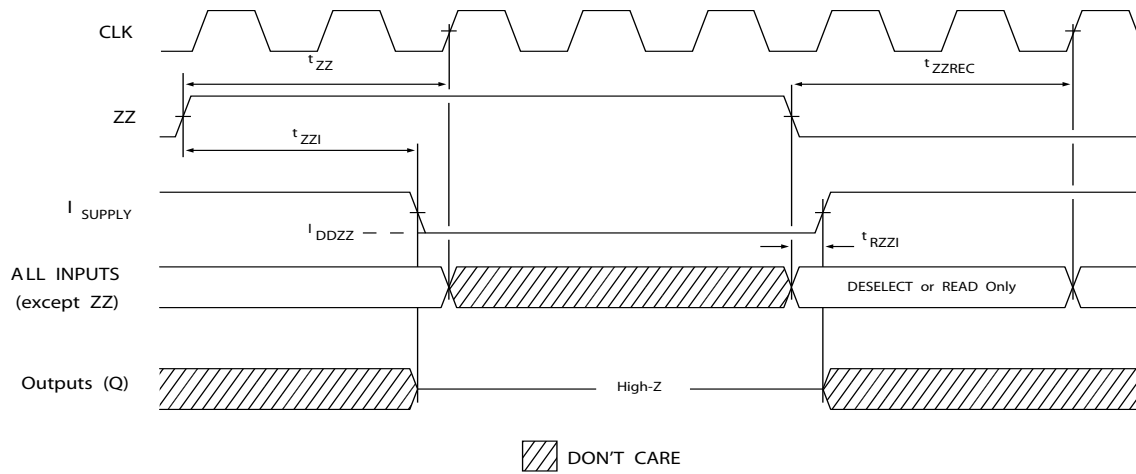

Notes

- 26. Device must be deselected when entering ZZ mode. See "Truth Table" on page 10 for all possible signal conditions to deselect the device.
- 27. DQs are in High Z when exiting ZZ sleep mode.

Ordering Information

The table below contains only the parts that are currently available. If you don't see what you are looking for, please contact your local sales representative. For more information, visit the Cypress website at www.cypress.com and refer to the product summary page at <http://www.cypress.com/products>

Cypress maintains a worldwide network of offices, solution centers, manufacturer's representatives and distributors. To find the office closest to you, visit us at <http://www.cypress.com/go/datasheet/offices>

Speed (MHz)	Ordering Code	Package Diagram	Package Type	Operating Range
133	CY7C1347G-133AXC	51-85050	100-pin TQFP (14 x 20 x 1.4 mm) Pb-free	Commercial
	CY7C1347G-133BGXC	51-85115	119-ball BGA (14 x 22 x 2.4 mm) Pb-free	
	CY7C1347G-133AXI	51-85050	100-pin TQFP (14 x 20 x 1.4 mm) Pb-free	Industrial
166	CY7C1347G-166AXC	51-85050	100-pin TQFP (14 x 20 x 1.4 mm) Pb-free	Commercial
200	CY7C1347G-200AXC	51-85050	100-pin TQFP (14 x 20 x 1.4 mm) Pb-free	Commercial
250	CY7C1347G-250AXC	51-85050	100-pin TQFP (14 x 20 x 1.4 mm) Pb-free	Commercial

Ordering Code Definitions

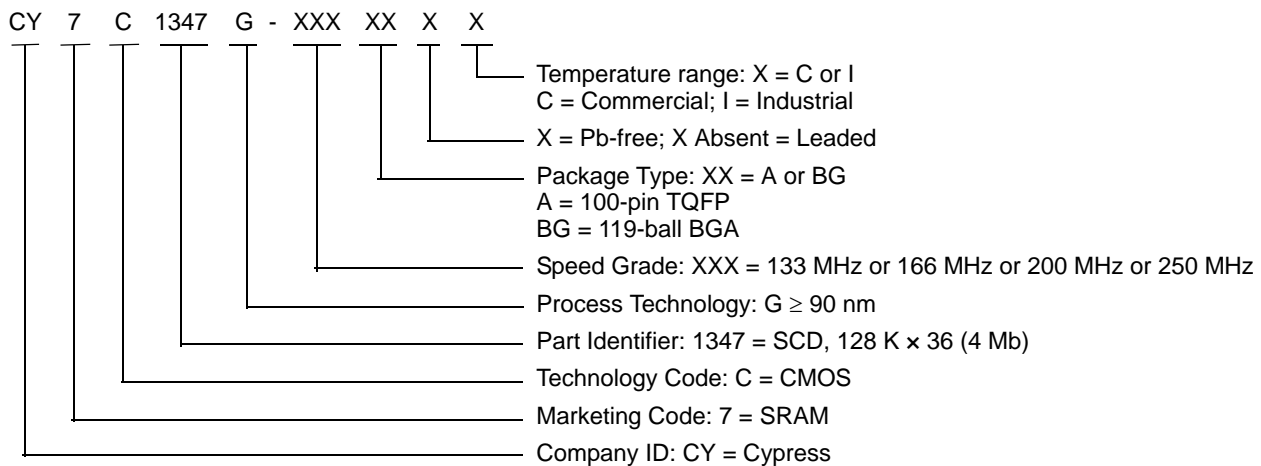

Package Diagrams

Figure 8. 100-pin TQFP (14 x 20 x 1.4 mm) A100RA Package Outline, 51-85050

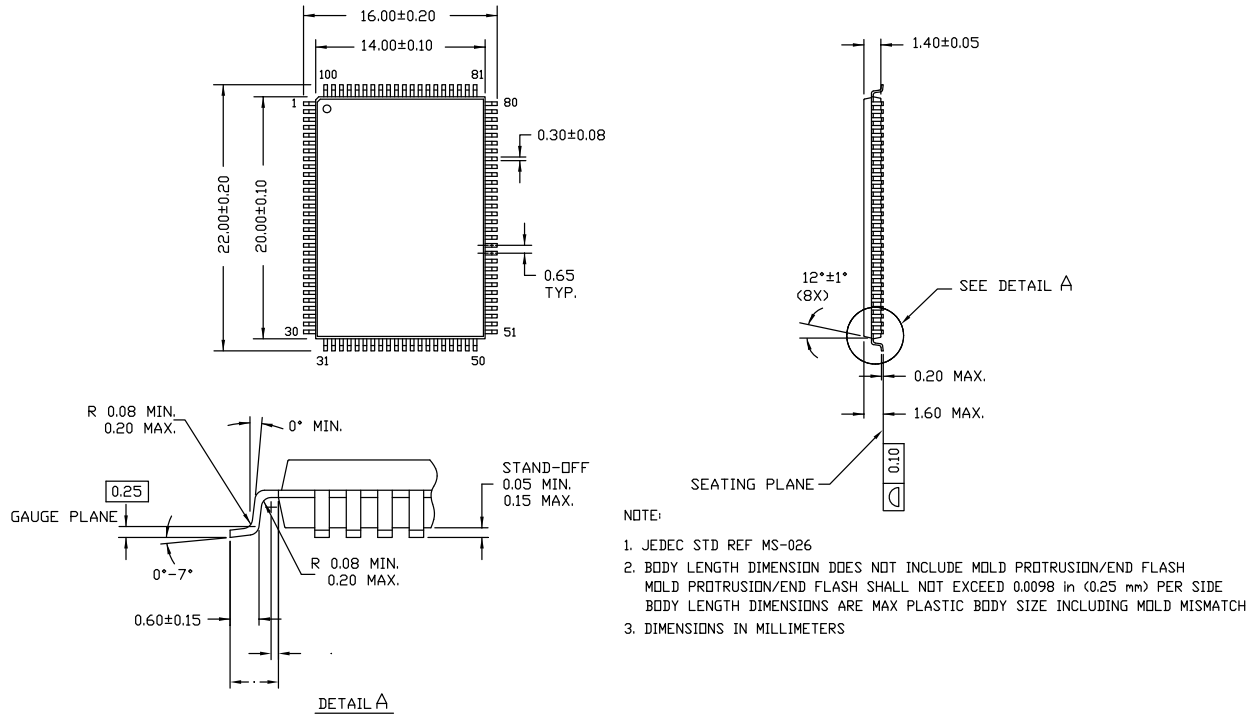

51-85050 *E

Package Diagrams (continued)

Figure 9. 119-ball PBGA (14 x 22 x 2.4 mm) BG119 Package Outline, 51-85115

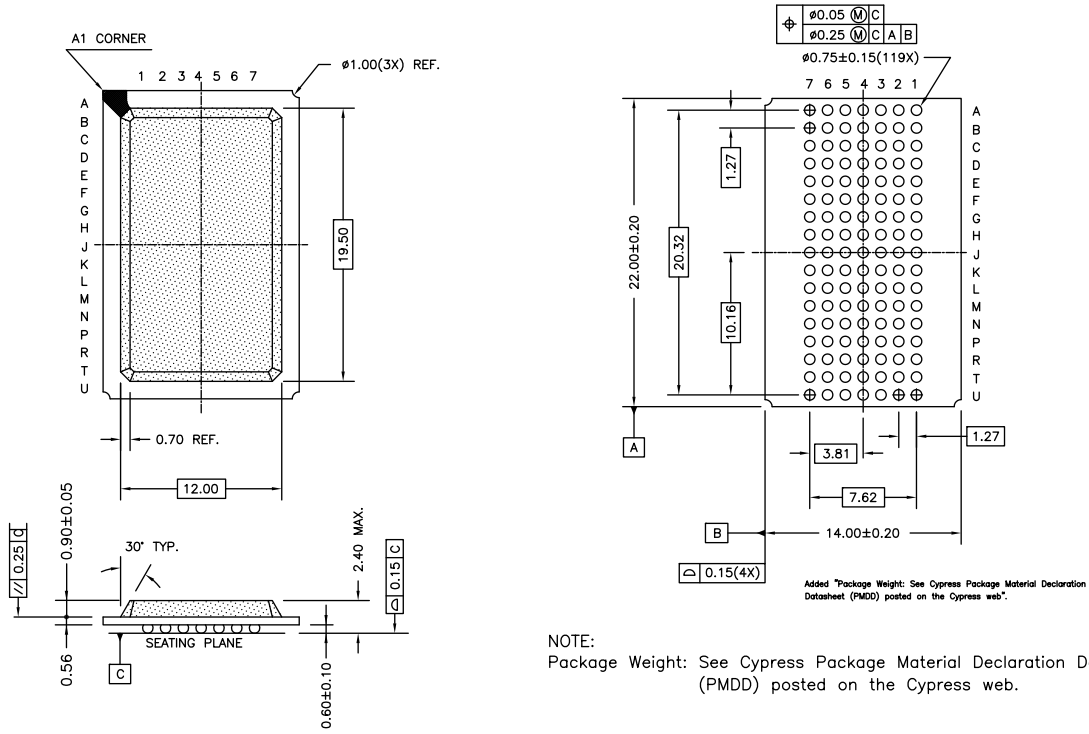

51-85115 *D

Acronyms

Acronym	Description
BGA	Ball Grid Array
\overline{CE}	Chip Enable
CMOS	Complementary Metal Oxide Semiconductor
I/O	Input/Output
JEDEC	Joint Electron Device Engineering Council
LMBU	Logical Multi-Bit Upsets
LSBU	Logical Single-Bit Upsets
\overline{OE}	Output Enable
SEL	Single Event Latch-up
SRAM	Static Random Access Memory
TQFP	Thin Quad Flat Pack
TTL	Transistor-Transistor Logic
\overline{WE}	Write Enable

Document Conventions

Units of Measure

Symbol	Unit of Measure
°C	degree Celsius
k Ω	kilohm
MHz	megahertz
μ A	microampere
μ s	microsecond
mA	milliampere
mV	millivolt
mm	millimeter
ms	millisecond
ns	nanosecond
Ω	ohm
%	percent
pF	picofarad
ps	picosecond
V	volt
W	watt

Errata

This section describes the Ram9 Sync ZZ pin issue. Details include trigger conditions, the devices affected, proposed workaround and silicon revision applicability. Please contact your local Cypress sales representative if you have further questions.

Part Numbers Affected

Density & Revision	Package Type	Operating Range
4Mb-Ram9 Synchronous SRAMs: CY7C134*G	100-pin TQFP	Commercial and Industrial
	119-ball BGA	

Product Status

All of the devices in the Ram9 4Mb Sync family are qualified and available in production quantities.

Ram9 Sync ZZ Pin Issues Errata Summary

The following table defines the errata applicable to available Ram9 4Mb Sync family devices.

Item	Issues	Description	Device	Fix Status
1.	ZZ Pin	When asserted HIGH, the ZZ pin places device in a "sleep" condition with data integrity preserved. The ZZ pin currently does not have an internal pull-down resistor and hence cannot be left floating externally by the user during normal mode of operation.	4M-Ram9 (90nm)	For the 4M Ram9 (90 nm) devices, there is no plan to fix this issue.

1. ZZ Pin Issue

■ Problem Definition

The problem occurs only when the device is operated in the normal mode with ZZ pin left floating. The ZZ pin on the SRAM device does not have an internal pull-down resistor. Switching noise in the system may cause the SRAM to recognize a HIGH on the ZZ input, which may cause the SRAM to enter sleep mode. This could result in incorrect or undesirable operation of the SRAM.

■ Trigger Conditions

Device operated with ZZ pin left floating.

■ Scope of Impact

When the ZZ pin is left floating, the device delivers incorrect data.

■ Workaround

Tie the ZZ pin externally to ground.

■ Fix Status

For the 4M Ram9 (90 nm) devices, there is no plan to fix this issue.

Document History Page

Document Title: CY7C1347G, 4-Mbit (128 K x 36) Pipelined Sync SRAM Document Number: 38-05516				
Revision	ECN	Orig. of Change	Submission Date	Description of Change
**	224364	RKF	See ECN	New data sheet.
*A	276690	VBL	See ECN	Updated Ordering Information (Changed TQFP package to Pb-free TQFP package, added comment on the BG and BZ Pb-free package availability below the table).
*B	333625	SYT	See ECN	Updated Features (Removed 225 MHz and 100 MHz frequencies related information). Updated Selection Guide (Removed 225 MHz and 100 MHz frequencies related information). Updated Pin Configurations (Updated Address Expansion balls in the pinouts for 100-pin TQFP Package as per JEDEC standards). Updated Pin Definitions . Updated Electrical Characteristics (Updated test conditions for V_{OL} and V_{OH} parameters, removed 225 MHz and 100 MHz frequencies related information). Updated Switching Characteristics (Removed 225 MHz and 100 MHz frequencies related information). Updated Thermal Resistance (Replaced TBDs for Θ_{JA} and Θ_{JC} to their respective values). Updated Ordering Information (By shading and unshading MPNs as per availability, changed the package name for 100-pin TQFP from A100RA to A101 in Package Name column, removed comment on the availability of BG Pb-free package).
*C	419256	R XU	See ECN	Changed status from Preliminary to Final. Changed address of Cypress Semiconductor Corporation from "3901 North First Street" to "198 Champion Court". Updated Truth Table (Swapped typo CE_2 and \overline{CE}_3 in the column heading). Updated Electrical Characteristics (Changed "Input Load Current except ZZ and MODE" to "Input Leakage Current except ZZ and MODE", updated Note 12 (Changed test condition from $V_{IH} \leq V_{DD}$ to $V_{IH} < V_{DD}$)). Updated Ordering Information (Updated part numbers, replaced Package Name column with Package Diagram in the Ordering Information table). Updated Package Diagrams .
*D	480124	VKN	See ECN	Updated Maximum Ratings (Added the Maximum Rating for Supply Voltage on V_{DDQ} Relative to GND). Updated Ordering Information (Updated part numbers).
*E	1078184	VKN	See ECN	Updated Switching Waveforms (Updated Figure 5).
*F	2633279	NXR / AESA	01/15/09	Updated Ordering Information (Updated part numbers). Updated in new template.
*G	2756998	VKN	08/28/09	Included Neutron Soft Error Immunity . Updated Ordering Information (By including parts that are available, and modified the disclaimer for the Ordering information). Updated Package Diagrams .
*H	2998771	NJY	08/02/10	Updated Package Diagrams . Updated in new template.
*I	3208774	NJY	03/29/2011	Updated Ordering Information (Updated part numbers) and added Ordering Code Definitions . Updated Package Diagrams .
*J	3310077	OSN	07/12/2011	Added Units of Measure . Updated in new template.

Document History Page (continued)

Document Title: CY7C1347G, 4-Mbit (128 K x 36) Pipelined Sync SRAM Document Number: 38-05516				
Revision	ECN	Orig. of Change	Submission Date	Description of Change
*K	3587066	NJY / PRIT	05/10/2012	Updated Features (Removed non Pb-free 119-ball BGA package and 165-ball FBGA package related information, removed Industrial Temperature related information). Updated Functional Description (Removed the Note “For best practice recommendations, refer to the Cypress application note, SRAM System Guidelines – AN1064. ” and its reference). Updated Pin Configurations (Removed 165-ball FBGA package related information). Updated Operating Range (Removed Industrial Temperature Range). Updated Capacitance (Removed 165-ball FBGA package related information). Updated Thermal Resistance (Removed 165-ball FBGA package related information). Updated Package Diagrams (Removed 165-ball FBGA package related information).
*L	3690005	PRIT	07/24/2012	No technical updates. Completing Sunset Review.
*M	3980577	PRIT	05/02/2013	Updated Package Diagrams : spec 51-85115 – Changed revision from *C to *D. Added Errata .
*N	4039646	PRIT	06/25/2013	Added Errata Footnotes. Updated in new template. Completing Sunset Review.
*O	4149033	PRIT	10/07/2013	Updated Errata .
*P	4419265	PRIT	06/25/2014	Included Industrial Temperature Range related information in all instances across the document. Updated Ordering Information (Updated part numbers). Updated Package Diagrams : spec 51-85050 – Changed revision from *D to *E. Completing Sunset Review.
*Q	4569232	PRIT	11/14/2014	Added related documentation hyperlink in page 1.

Sales, Solutions, and Legal Information

Worldwide Sales and Design Support

Cypress maintains a worldwide network of offices, solution centers, manufacturer's representatives, and distributors. To find the office closest to you, visit us at [Cypress Locations](#).

Products

Automotive	cypress.com/go/automotive
Clocks & Buffers	cypress.com/go/clocks
Interface	cypress.com/go/interface
Lighting & Power Control	cypress.com/go/powerpsoc cypress.com/go/plc
Memory	cypress.com/go/memory
PSoC	cypress.com/go/psoc
Touch Sensing	cypress.com/go/touch
USB Controllers	cypress.com/go/USB
Wireless/RF	cypress.com/go/wireless

PSoC[®] Solutions

psoc.cypress.com/solutions
[PSoC 1](#) | [PSoC 3](#) | [PSoC 4](#) | [PSoC 5LP](#)

Cypress Developer Community

[Community](#) | [Forums](#) | [Blogs](#) | [Video](#) | [Training](#)

Technical Support

cypress.com/go/support

© Cypress Semiconductor Corporation, 2004-2014. The information contained herein is subject to change without notice. Cypress Semiconductor Corporation assumes no responsibility for the use of any circuitry other than circuitry embodied in a Cypress product. Nor does it convey or imply any license under patent or other rights. Cypress products are not warranted nor intended to be used for medical, life support, life saving, critical control or safety applications, unless pursuant to an express written agreement with Cypress. Furthermore, Cypress does not authorize its products for use as critical components in life-support systems where a malfunction or failure may reasonably be expected to result in significant injury to the user. The inclusion of Cypress products in life-support systems application implies that the manufacturer assumes all risk of such use and in doing so indemnifies Cypress against all charges.

Any Source Code (software and/or firmware) is owned by Cypress Semiconductor Corporation (Cypress) and is protected by and subject to worldwide patent protection (United States and foreign), United States copyright laws and international treaty provisions. Cypress hereby grants to licensee a personal, non-exclusive, non-transferable license to copy, use, modify, create derivative works of, and compile the Cypress Source Code and derivative works for the sole purpose of creating custom software and or firmware in support of licensee product to be used only in conjunction with a Cypress integrated circuit as specified in the applicable agreement. Any reproduction, modification, translation, compilation, or representation of this Source Code except as specified above is prohibited without the express written permission of Cypress.

Disclaimer: CYPRESS MAKES NO WARRANTY OF ANY KIND, EXPRESS OR IMPLIED, WITH REGARD TO THIS MATERIAL, INCLUDING, BUT NOT LIMITED TO, THE IMPLIED WARRANTIES OF MERCHANTABILITY AND FITNESS FOR A PARTICULAR PURPOSE. Cypress reserves the right to make changes without further notice to the materials described herein. Cypress does not assume any liability arising out of the application or use of any product or circuit described herein. Cypress does not authorize its products for use as critical components in life-support systems where a malfunction or failure may reasonably be expected to result in significant injury to the user. The inclusion of Cypress' product in a life-support systems application implies that the manufacturer assumes all risk of such use and in doing so indemnifies Cypress against all charges.

Use may be limited by and subject to the applicable Cypress software license agreement.