

Features

- Low loss
- Flat Low Ripple
- High Rejection

Description

Surface mount, silver (Ag) coated ceramic duplexer. Developed for use in W-CDMA infrastructure applications.

Weight: 3.0 grams typical

Material: Filter is composed of a ceramic block plated with Ag and a shield made of nickel silver plated steel.

Filter complies with RoHS standards.



Electrical Specifications

Parameter	Frequency (MHz)	Typical @ 25°C	Spec. @ 25°C	Spec. Over -40°C to +85°C
High Band Response (S21)				
Passband Insertion Loss	2110-2170	1.09 dB	1.3 dB max	1.50 dB max
Passband Return Loss @ S22	2110-2170	18.0dB	12.5 dB min	12.0 dB min
Passband Return Loss @ ANT	2110-2170	19.0 dB	12.5 dB min	12.0 dB min
Passband Ripple	2110-2170	0.05	0.60 dB max	0.80 dB max
Attenuation:	1920-1980	61.3 dB	55.5 min	55.0 dB min
Low Band Response (S13)				
Passband Insertion Loss	1920-1980	0.91 dB	1.3 dB max	1.5 dB max
Passband Return Loss @ S33	1920-1980	17.0dB	12.5 dB min	12.0 dB min
Passband Return Loss @ ANT	1920-1980	18.0 dB	12.5 dB min	12.0 dB min
Passband Ripple	1920-1980	0.05 dB	0.60 dB max	0.80 dB max
Attenuation:	2110-2170	56.8 dB	55.5 dB min	55 dB min
Isolation				
Rejection @ Mid Band	1980 - 2110	41 dB	41.5 dB min	40 dB min
Rejection @ High band	2110-2170	58 dB	55.5 dB min	55 dB min
Rejection @ Low band	1920-1980	65 dB	55.5 dB min	55 dB min

Note: Supplier shall test each filter to the critical electrical specifications of the above table. Any subsequent audits may deviate from in value due to measurement repeatability among different test systems. Such deviations shall not exceed the following limits:

Specification	Allowance
Insertion Loss	0.1 dB
Return Loss	1.0 dB
Stopbands	1.0 dB

*This product is covered by one or more of the following U.S. and foreign patents including: US 4,692,726;US 4,742,562; US 4,800,348;US 4,829,274;US 5,146,193;EP 0573597;DE 0573597;FR 0573597;JP 508149/92;KR 142171;US 5,162,760;US 5,218,329;US 5,250,916;US 5,327,109;US 5,488,335;CA 2114029;FR 9306297;GB 2273393;JP 3205337;KR 115113;CN 93106228.4;US 5,512,866;EP 0706719;DE 0706719;FR 0706719;GB 0706719;CN 95190359.4;US 5,602,518;US 5,721,520;US 5,745,018;EP 0910875;DE 0910875;DK 0910875;FR 0910875;GB 0910875;IE 0910875;JP 505182/98;KR 10-323013;US 5,994,978;US 6,462,629;CN 00810420.4;US 6,559,735;US 6,650,202;US 6,834,429. Other US and foreign patents pending.

CTS Corporation 2006 reserves all copyrights in the layout, design and configuration of the patterns on this product.

Mechanical Drawing

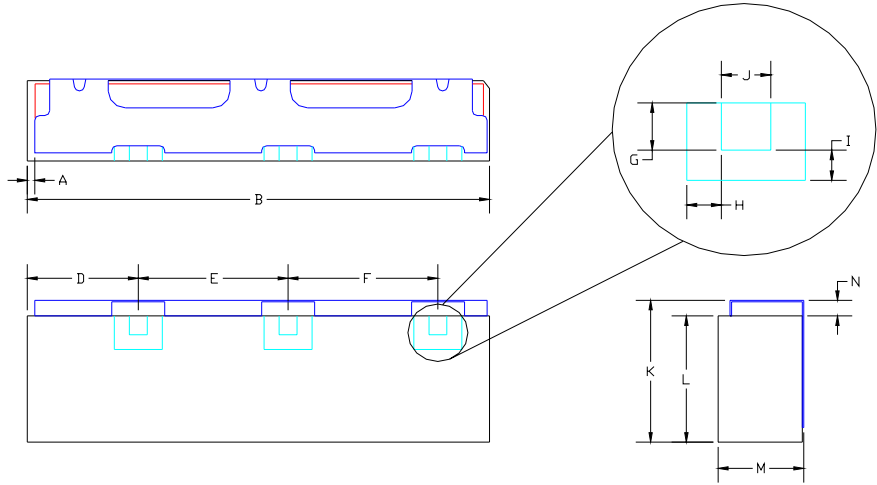

Dim	Nominal (mm)	Tolerance (mm) +/- or max
A	0.25	0.25
B	24.04	max
C		
D	2.72	0.25
E	7.44	0.13
F	10.52	0.13
G	1.02	0.13
H	0.79	0.13
I	0.79	0.13
J	0.89	0.13
K	6.75	max
L	5.64	max
M	4.60	max
N	0.84	0.13

Electrical response

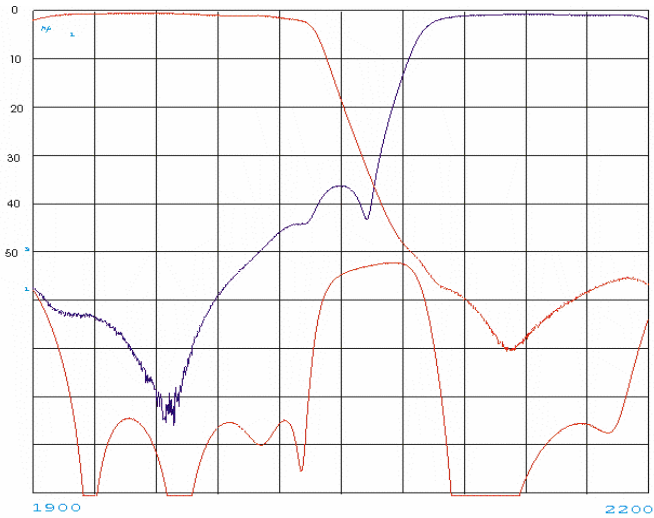

PCB Layout

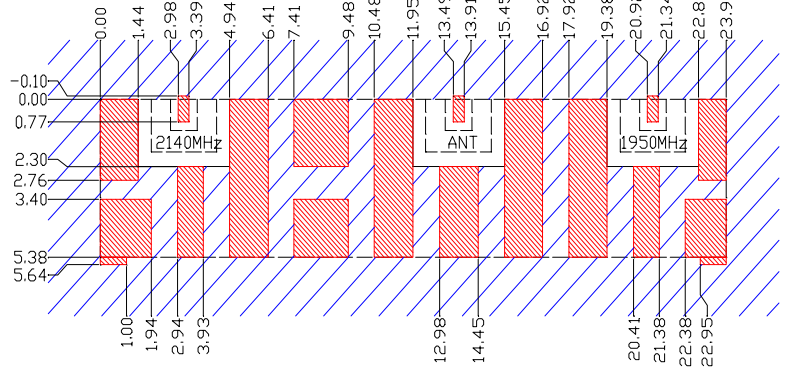

- Filter Outline
- Exposed Conductor
- Solder Resist Over Dielectric
- Solder Resist Over Conductor Shield

Packaging and Marking

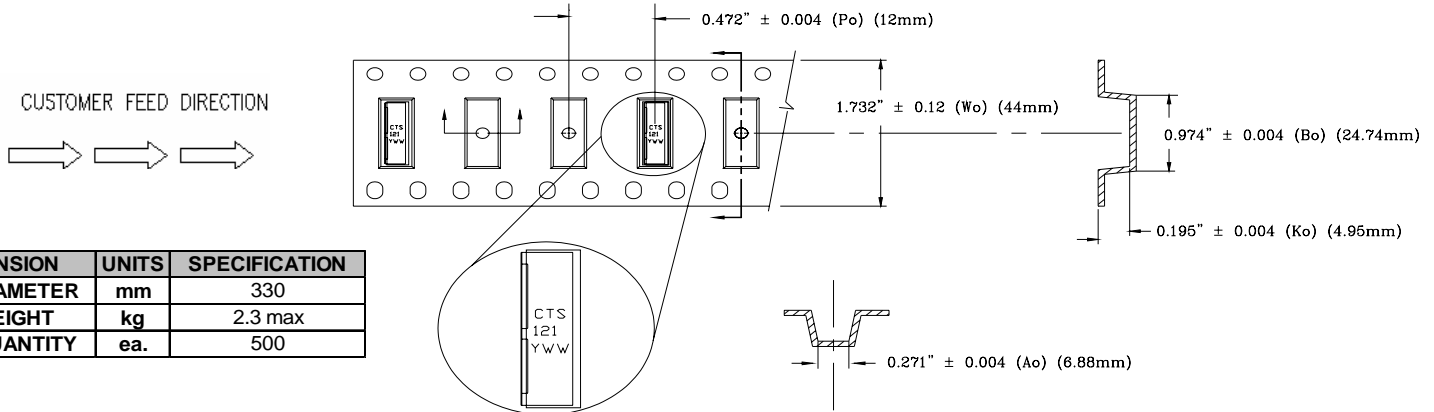

DIMENSION	UNITS	SPECIFICATION
REEL DIAMETER	mm	330
REEL WEIGHT	kg	2.3 max
REEL QUANTITY	ea.	500