

- ◆ Frequency Stability to ± 20 PPM
- ◆ +3.3Vdc or +5.0Vdc Operation
- ◆ HCMOS Output
- ◆ Operating Temperature to -40°C to $+85^{\circ}\text{C}$
- ◆ Output Enable Standard
- ◆ Tape & Reel Packaging



ELECTRICAL CHARACTERISTICS

Parameter	Symbol	Min	Typical	Max	Unit
Output Clock Frequency Model 357S, 357W Model 357L, 357V	f_o	1.5 1.5	- -	52 52	MHz MHz
Frequency Stability (Note 1) (See Ordering Information)	-	-	-	20, 25, 50	\pm ppm
Absolute Pull Range (Note 2) (See Ordering Information)	-	32, 50, 80, 100	-	-	\pm ppm
Supply Voltage Model 357S, 357W Model 357L, 357V	V_{CC}	4.5 2.97	5.0 3.3	5.5 3.63	V V
Operating Supply Current $C_L = 15\text{pf}$ Model 357S, 357W Model 357L, 357V	I_{CC}	- -	- -	40 50	mA mA
Output load	C_L	-	-	15	pf
Control Voltage Model 357S, 357W Model 357L, 357V	V_C	0.5 0.3	2.5 1.65	4.5 3.0	V V
Output Voltage Levels Logic '1' Level $I_{OH} = 14\text{ mA}$ Logic '0' Level $I_{OL} = -14\text{ mA}$	V_{OH} V_{OL}	$0.9 * V_{CC}$ -	- -	- $0.1 * V_{CC}$	V V
Output Transition Times (10% to 90%) Rise & Fall Time $C_L = 15\text{pf}$	T_R, T_F	-	-	5.0	nS
Output Duty Cycle (@ 50% Level)	SYM	45	-	55	%
Start Up Time	-	-	-	10.0	mS
Phase Jitter (Bandwidth 12K – 20M Hz)	-	-	< 1	-	pS RMS
Linearity	L	-	-	10	%
Transfer Function	-	-	Positive	-	-
Input Impedance	Z_C	50	-	-	KOhms
Modulation Roll-off (@ -3dB)	-	10	-	-	KHz
Tri-state – Oscillator Run Enable Input Voltage Disable Input Voltage Enable/ Disable Time	V_{IH} V_{IL} t_{PLZ}	2.5 - -	- - -	- 0.5 100	V V nS

Notes

1. Inclusive of initial tolerance at the time of shipment, changes in supply voltage, load and operating temperature.
2. Minimum guaranteed frequency shift from f_o over variations in temperature, aging, power supply and load at an average operating temperature of $+40^{\circ}\text{C}$ for 10 years.

ORDERING INFORMATION

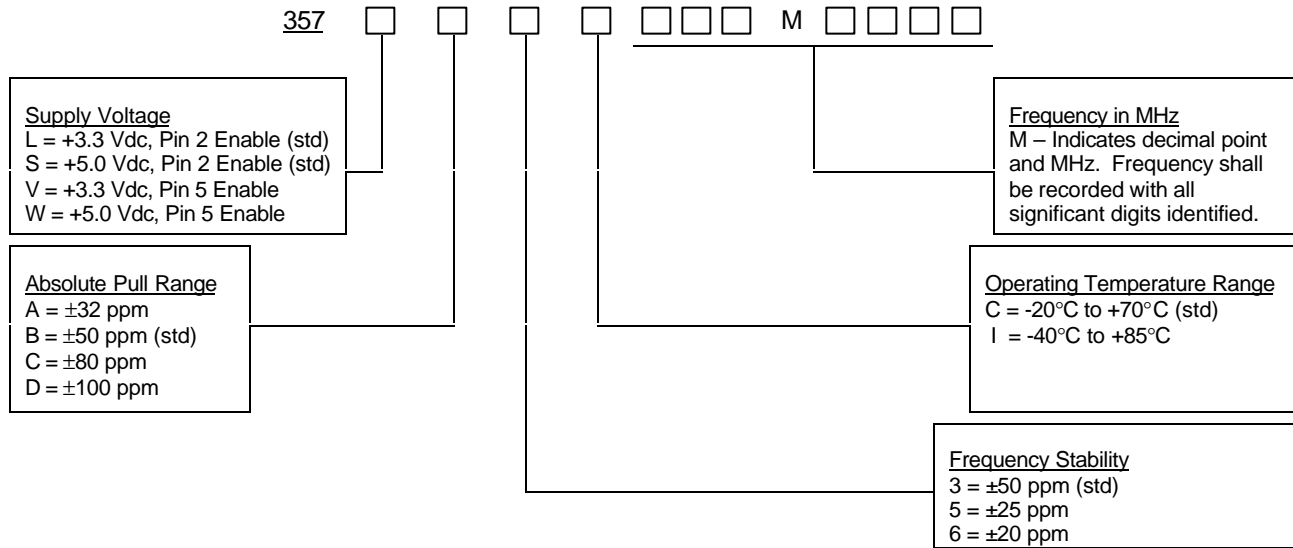

Example P/N: 357LB3C019M4400

MECHANICAL SPECIFICATIONS

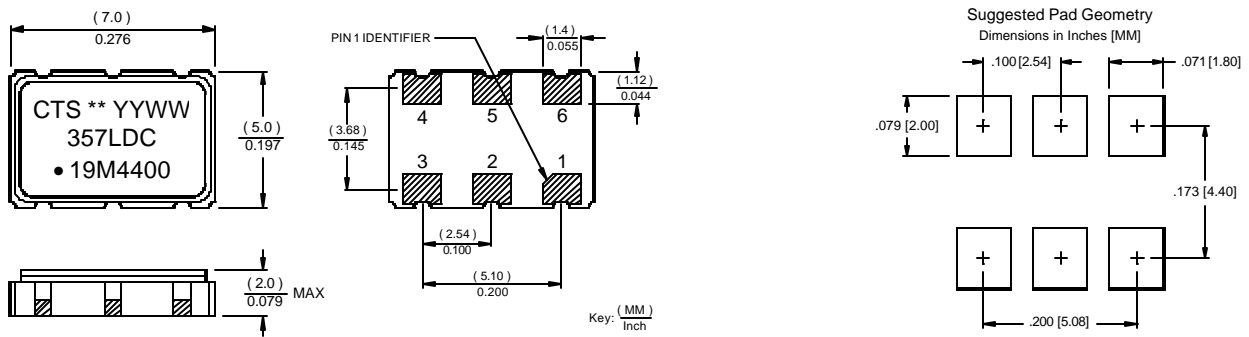

** Manufacturing Site Code.
Frequency shall be marked with 4 significant digits to the right of the "M".

Terminations plated with 0.3 – 1.0 um gold (Au).

Pin	Symbol	Functional Description
1	VC	Control Voltage
2	EOH	Enable
3	GND	Circuit and Package Ground
4	Output	RF Output
5	N.C.	Not Connected Internally
6	Vcc	Supply Voltage

Enable Truth Table

Pin 2	Pin 4
"1"	Output
"0"	High Imp.
Open	Output

QUALITY AND RELIABILITY

Quality Systems meet or exceed the requirements of ISO 9000: 2000 standards.
Reliability Audits are performed on this or similar products with results available upon request.

ENVIRONMENTAL SPECIFICATIONS

- Storage Temperature: -55°C to +125°C
- Temperature Cycle: 400 cycles, -55°C to +125°C, 10 min dwell, 1 min transfer
- Mechanical Shock: 1,500g's, 0.5mS, ½ sinewave, 3 shocks each direction, in 3 planes
- Sinusoidal Vibration: 0.06" D.A., 10 to 55 Hz and 20g's, 55 to 2,000 Hz, 3 cycles per plane
- Gross Leak: No leak shall appear while immersed in an FC40 or equivalent liquid at 125°C for 20 seconds
- Fine Leak: Mass spectrometer leak rates less than 2×10^{-8} cc/sec air equivalent maximum
- Resistance to Soldering Heat: Product must survive 3 reflows of 260°C peak, 10 seconds maximum
- High Temperature Operating Bias: 2,000 hours at 125°C, disregarding frequency shift
- Frequency Aging: < 5 ppm shift in 1,000 hours at 85°C

Suggested Reflow Profile

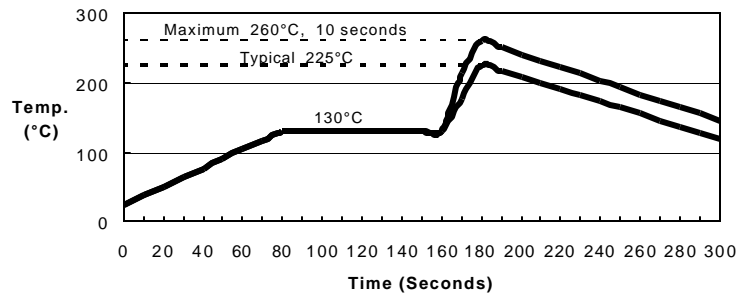

TAPE AND REEL INFORMATION

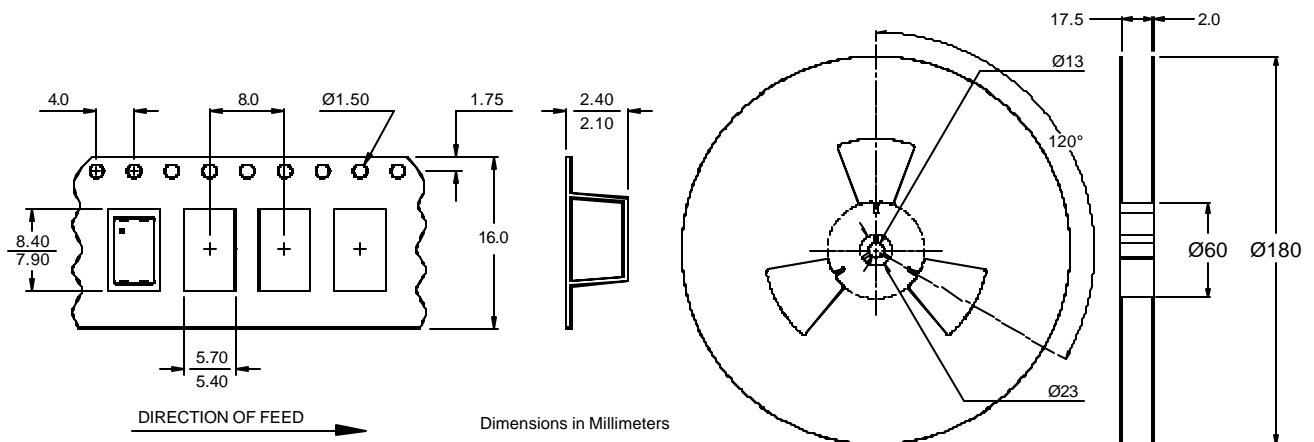

Device quantity shall be 1,000 pieces on a 180mm reel.