

FEATURES

- HCMOS Output
- **Optional Voltage Control for Frequency Tuning [VCTCXO]**
- 7.0mmx5.0mm Surface Mount Package
- Frequency Range 5 – 40 MHz
- Fundamental Crystal Design
- Operating Voltage, +3.0Vdc, +3.3Vdc or +5.0Vdc
- Overall Frequency Stability ± 4.6 ppm
- Operating Temperature to -40°C to $+85^{\circ}\text{C}$
- Tape & Reel Packaging Standard, EIA-418
- **RoHS/Green Compliant [6/6]**

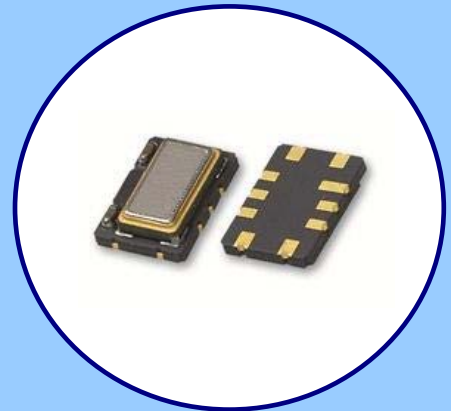

APPLICATIONS

The Model 579, a quartz based analog TCXO with HCMOS output and optional frequency tuning, is suitable for applications requiring Stratum 3 performance such as base stations, Microcells, Femtocells, 1588 and Synchronous Ethernet timing, wireless communications, test and measurement.

ORDERING INFORMATION

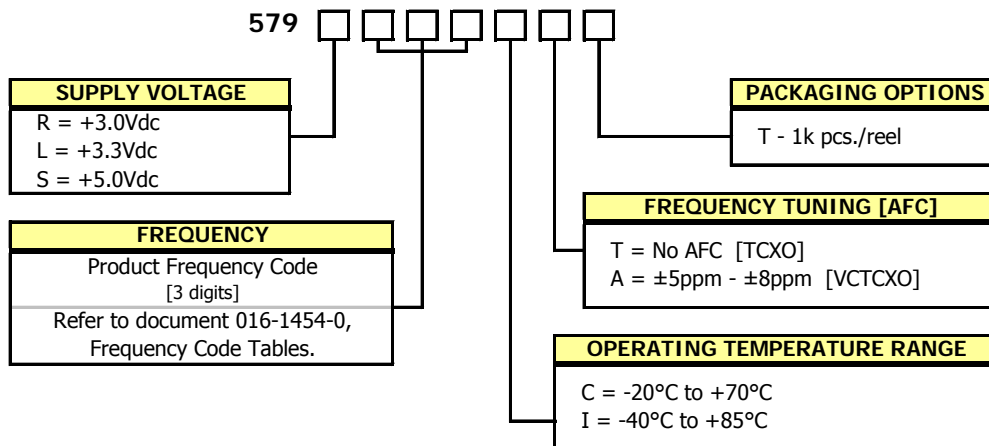

**Not all performance combinations and frequencies may be available.
Contact your local CTS Representative or CTS Customer Service for availability.**

PACKAGING INFORMATION [reference]

Device quantity is 1k pcs. maximum per 180mm reel.

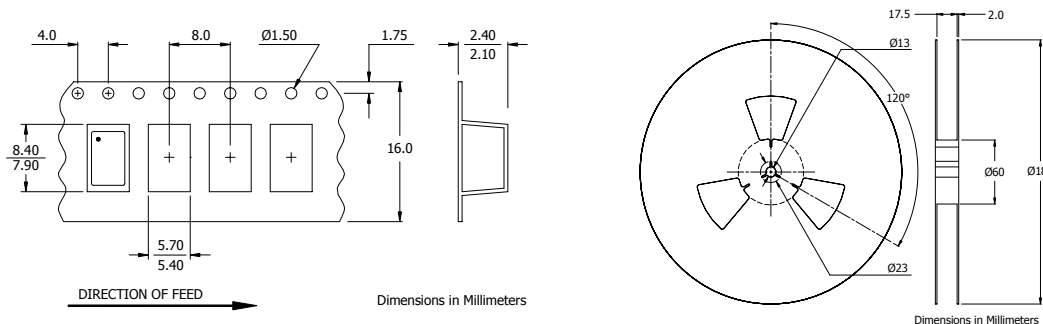

ELECTRICAL CHARACTERISTICS

PARAMETER	SYMBOL	CONDITIONS	MIN	TYP	MAX	UNIT
Maximum Supply Voltage	V _{CC}	-	-0.6	-	6.0	V
Maximum Control Voltage	V _C	-	-0.5	-	V _{CC}	V
Storage Temperature	T _{STG}	-	-40	-	+100	°C
Operating Temperature	T _A	-	-20	+25	+70	°C
Order Code 'C'			-40		+85	
Order Code 'I'						
Frequency Range	f ₀	-	5	-	40	MHz
Supply Voltage	V _{CC}	±5%	2.85	3.0	3.15	V
Order Code 'R'			3.14	3.3	3.47	
Order Code 'L'			4.75	5.0	5.25	
Order Code 'S'						
Supply Current	I _{CC}	-	-	-	6.0	mA
Frequency Stability	Δf/f ₀	Reference to f ₀ , Including 20 years aging @ +25°C, at time of shipment [Fmax. - Fmin.]/2, over -40°C to +85°C ±5% change @ +25°C ±5% change 20 years @ +40°C [Fmax. - Fmin.]/2, over 24 hours ¹	-	-	4.60	± ppm
Overall Frequency Stability			-	-	1.00	
vs. Initial Calibration			-	-	0.28	
vs. Operating Temperature			-	-	0.40	
vs. Supply Voltage			-	-	0.10	
vs. Load			-	-	2.80	
vs. Aging			-	-	0.37	
Holdover	Δf/f ₀					
Control Voltage	V _C	-	0.5	1.5	2.5	V
Frequency Tuning [VCTCXO Only]	-	V _C = 1.5V ±1.0V, monotonic positive		5 - 8		± ppm
V _C Input Impedance	ZV _C	-	100	-	-	kOhm
Output Waveform		HCMOS				
Output Voltage Levels						
Logic '1' Level	V _{OH}	HCMOS Load	0.9*V _{CC}	-	-	V
Logic '0' Level	V _{OL}	HCMOS Load	-	-	0.1*V _{CC}	
Output Load	C _L	-	-	-	15	pF
Rise and Fall Time	T _R , T _F	@ 20% - 80% Levels	-	3.0	6.0	ns
Output Duty Cycle	SYM	@ 50% Level	45	-	55	%
Start Up Time	T _S	-	-	-	2	ms
Enable Function						
Enable Input Voltage	V _{IH}	Pin 8 Logic '1', Output Enabled	0.7*V _{CC}	-	-	V
Disable Input Voltage	V _{IL}	Pin 8 Logic '0', Output Disabled [High Imp]	-	-	0.3*V _{CC}	
Phase Noise ¹	-	-				dBc/Hz

Notes:

- Phase Noise performance may vary based on output frequency. See example plot at 10 MHz below.

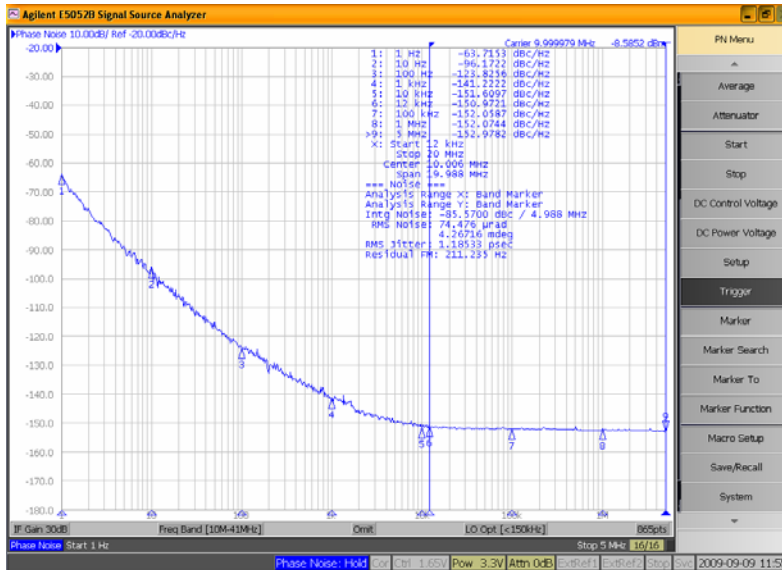

MECHANICAL SPECIFICATIONS

PACKAGE DRAWING

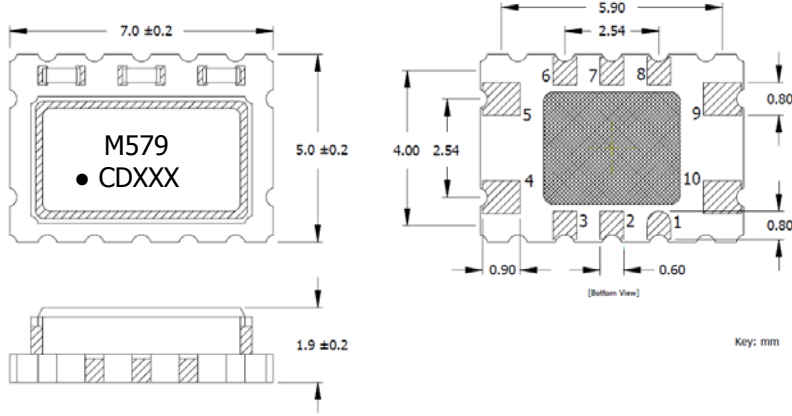

MARKING INFORMATION

1. M579 – CTS Model Series.
 2. ● – Pin 1 identifier.
 3. C – CTS identifier.
 4. D – Date code. See Table II for codes.
 5. xxx – Frequency Code.
- Refer to document 016-1454-0, Frequency Code Tables.

NOTES

1. DO NOT make connections to non-labeled pins. Castellation pins may have internal connections used in the manufacturing process.
2. Termination pads (e4); barrier plating is nickel [Ni] with gold [Au] flash plate.
3. Reflow conditions per JEDEC J-STD-020, 260°C maximum.
4. MSL = 1.

D.U.T. PIN ASSIGNMENTS

PIN	SYMBOL	DESCRIPTION
4	GND	Circuit & Package Ground
5	Output	HCMOS Output
8	EOH	Tri-State Enable
9	V _{CC}	Supply Voltage
10	V _C	Control Voltage – VCTCXO [Note 1] GND - TCXO

NOTES

1. Connect to ground for TCXO [no AFC] option.

SUGGESTED SOLDER PAD GEOMETRY

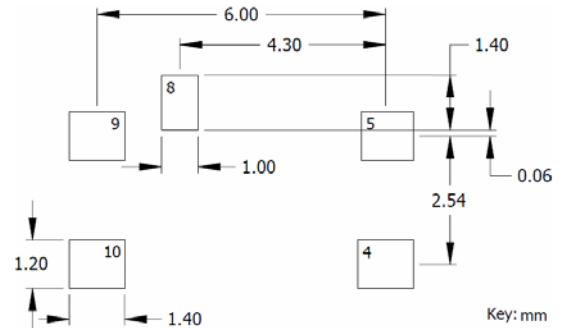

TEST CIRCUIT – CMOS LOAD

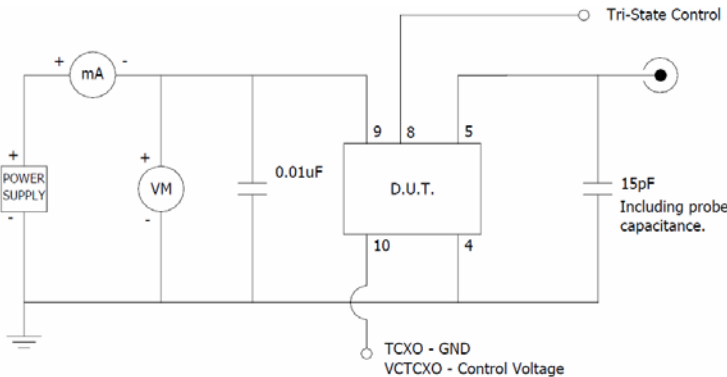

TABLE II – DATE CODE

YEAR		MONTH														
		JAN	FEB	MAR	APR	MAY	JUN	JUL	AUG	SEP	OCT	NOV	DEC			
2001	2005	2009	2013	2017	A	B	C	D	E	F	G	H	J	K	L	M
2002	2006	2010	2014	2018	N	P	Q	R	S	T	U	V	W	X	Y	Z
2003	2007	2011	2015	2019	a	b	c	d	e	f	g	h	j	k	l	m
2004	2008	2012	2016	2020	n	p	q	r	s	t	u	v	w	x	y	z