

8

7

6

5

4

3

2

1

CINCH PART NUMBER MATRIX

DRAWING REVISIONS (RELEASE DATE ON FILE)			
REV	DOCUMENT	APP	APPROVAL DATE
A	CO 1537	A.E.	6/1/11

P/N: 5810118038

P/N: 5810118039

18-WAY HEADER ASSEMBLY WITHOUT FERRITE FILTERS

18-WAY HEADER ASSEMBLY WITH FERRITE FILTERS

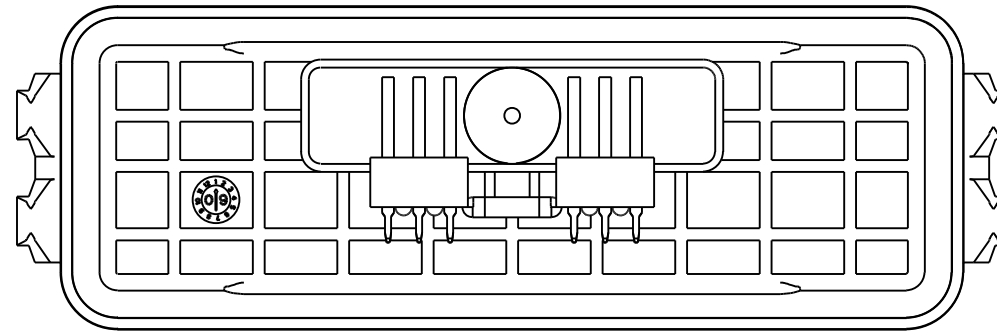
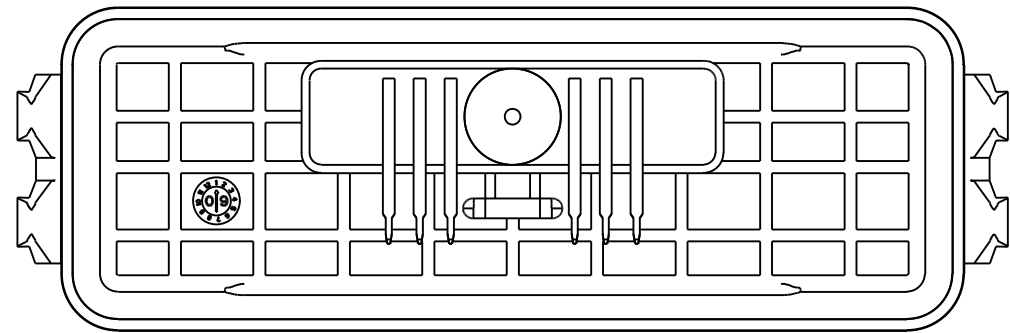
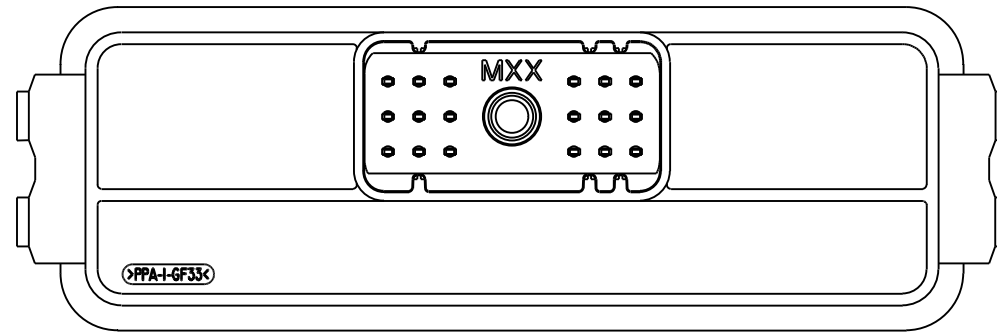
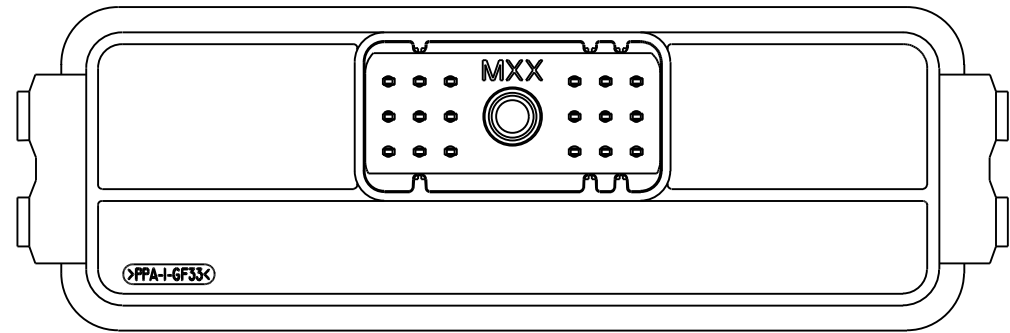

MATES WITH CINCH HARNESS CONNECTOR
P/N: 5810118023

NOTES:

- ALL DIMENSIONS ARE IN INCHES; DIMENSIONS INSIDE [.XX] ARE IN mm, AS REFERENCE ONLY
- MATERIALS:
 INTERFACE SEAL: SILICONE RUBBER, COLOR BLUE
 INSULATOR: 30% GLASS FILLED POLYMER, COLOR BLACK
 BUSHING: BRASS ALLOY, UNPLATED 10-24 UNC THREAD
 TERMINAL BLADES: 1.5 mm BRASS WITH TIN OVER NICKEL PLATING
 FILTERS: FERRITE BLOCKS
- ALL HEADERS ARE REFLOW OR WAVE SOLDERING PROCESS, ROHS COMPLIANT
- SUGGESTED PCB THICKNESS: .062 [1.57]
- IF USING FERRITE FILTER VERSION, TRACES SHOULD BE AVOIDED UNDER THE FERRITE SPACER FEET. SEE "PCB TOP SIDE PIN AREA WITH FERRITES DETAIL" - PAGE 3.
- MATES WITH CINCH SHS PUSH-TO-SEAT HARNESS CONNECTORS (SEE TABLE ABOVE)
- TORQUE MATING CONNECTOR SCREW TO 15 - 20 IN*LBS [1.70 - 2.26 N*m]

UNITS ENGLISH INCHES		PRO/E		CINCH		MODELED BY: A. ECKHART			
DO NOT SCALE DRAWING		DESIGN ENGINEER A. ECKHART	DATE 4/1/09	TITLE 18-WAY HEADERS MODICE ME		1700 FINLEY RD LOMBARD, IL. 60148			
CONFIDENTIAL THIS DOCUMENT IS THE PROPERTY OF CINCH. NEITHER THIS DOCUMENT NOR ANY OF THE INFORMATION CONTAINED IN IT MAY BE DUPLICATED OR DISCLOSED WITHOUT PRIOR WRITTEN CONSENT OF CINCH. ©COPYRIGHT 2009 CINCH				MATERIAL SEE NOTES		CONTROL SPEC NUMBER			
				MATERIAL SPEC NUMBER		FINISH		PROJECT NUMBER A14926	
				CAD FILE NUMBER 5810118038S		DRAWING NUMBER 5810118038S			
				CAGE IDENT NO. 71785	SIZE B	SCALE 1:1	SHEET 1 OF 3		

8

7

6

5

4

3

2

1

8 7 6 5 4 3 2 1

D

D

C

C

B

B

A

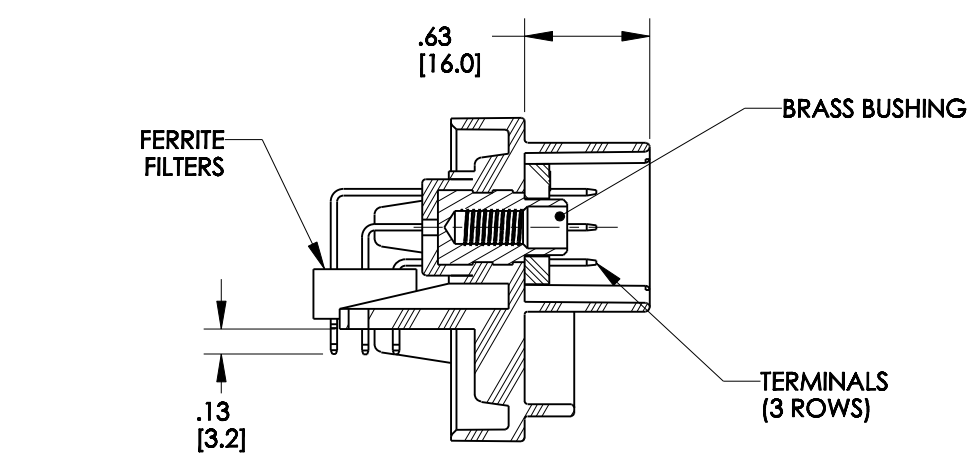

SECTION A-A

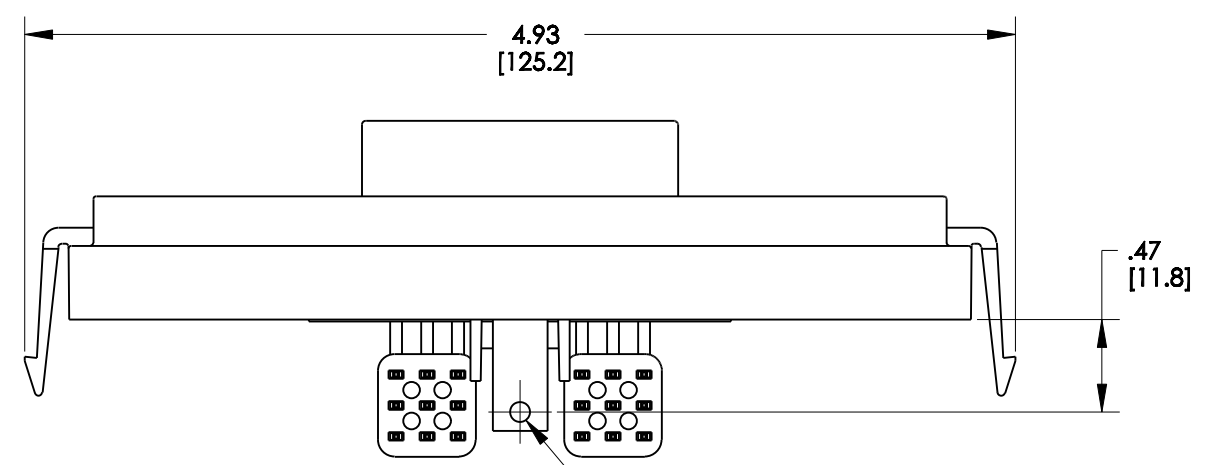
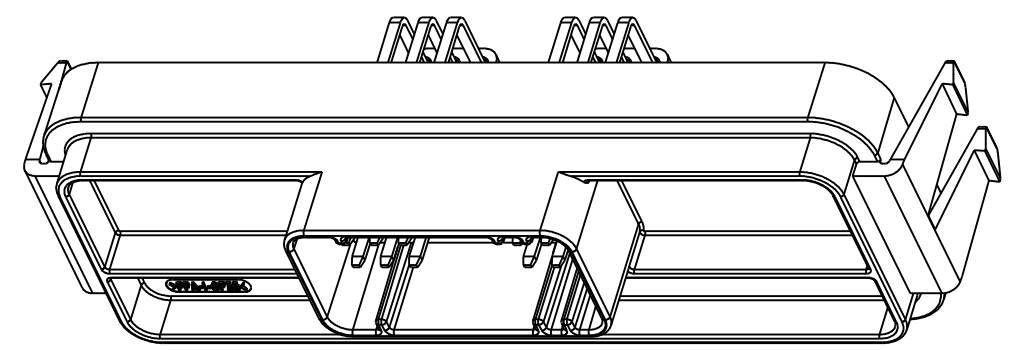
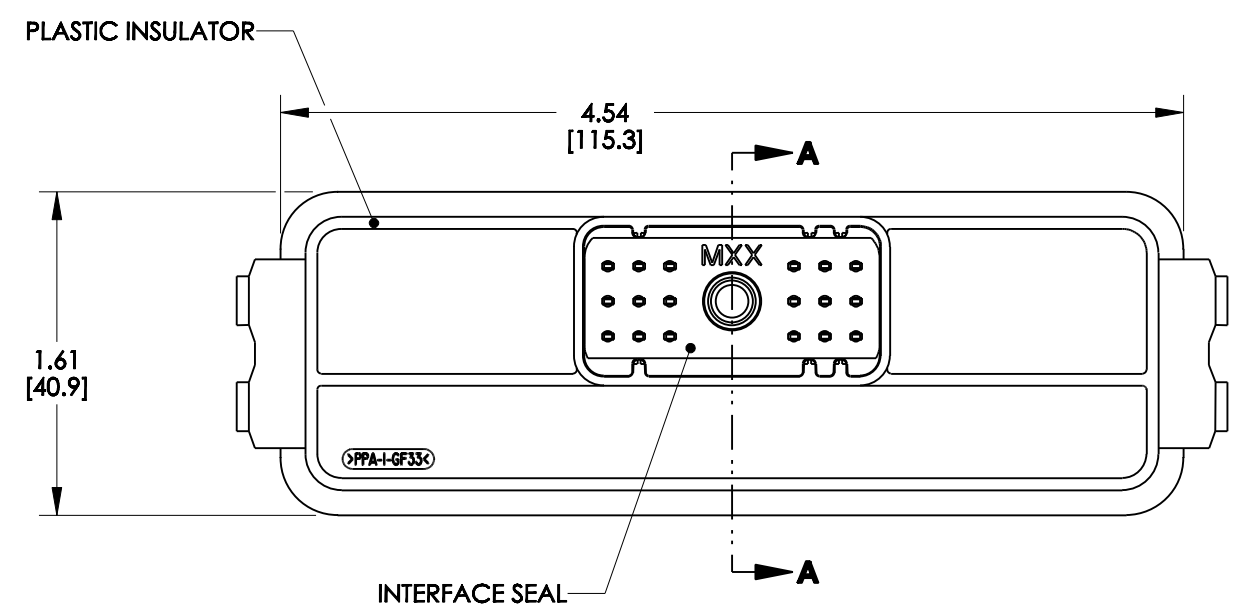

**CINCH P/N: 5810118039 SHOWN
(HEADER WITH FILTERS)**

FOR PCB MOUNTING, #4 THREAD CUTTING SCREW (TYPE 23 OR SIMILAR) IS RECOMMENDED; TORQUE TO 2-3 IN*LBS [0.23-0.34Nm]

UNITS ENGLISH INCHES		CINCH		1700 FINLEY RD LOMBARD, IL. 60148	
DO NOT SCALE DRAWING		TITLE 18-WAY HEADERS MODICE ME			
		PRO/E DRAWING			
CAD FILE NUMBER 5810118038S		DRAWING NUMBER 5810118038S		REV A	
CAGE IDENT NO. 71785	SIZE B	SCALE 1:1	SHEET 2 OF 3		
<small> CONFIDENTIAL THIS DOCUMENT IS THE PROPERTY OF CINCH. NEITHER THIS DOCUMENT NOR ANY OF THE INFORMATION CONTAINED IN IT MAY BE DUPLICATED OR DISCLOSED WITHOUT PRIOR WRITTEN CONSENT OF CINCH. ©COPYRIGHT 2009 CINCH </small>					

8 7 6 5 4 3 2 1

PCB TOP SIDE GENERAL ZONING AND KEEP-OUT AREAS

PCB BOTTOM SIDE GENERAL ZONING AND KEEP-OUT AREAS

PCB OVERALL DIMENSIONS AND HOLE LOCATIONS

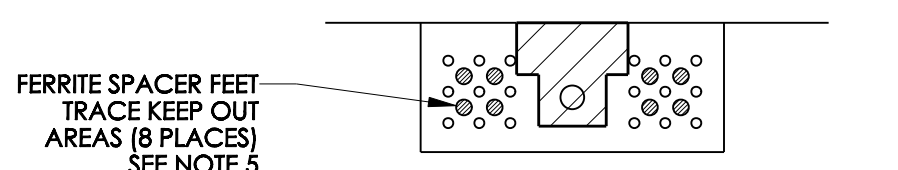
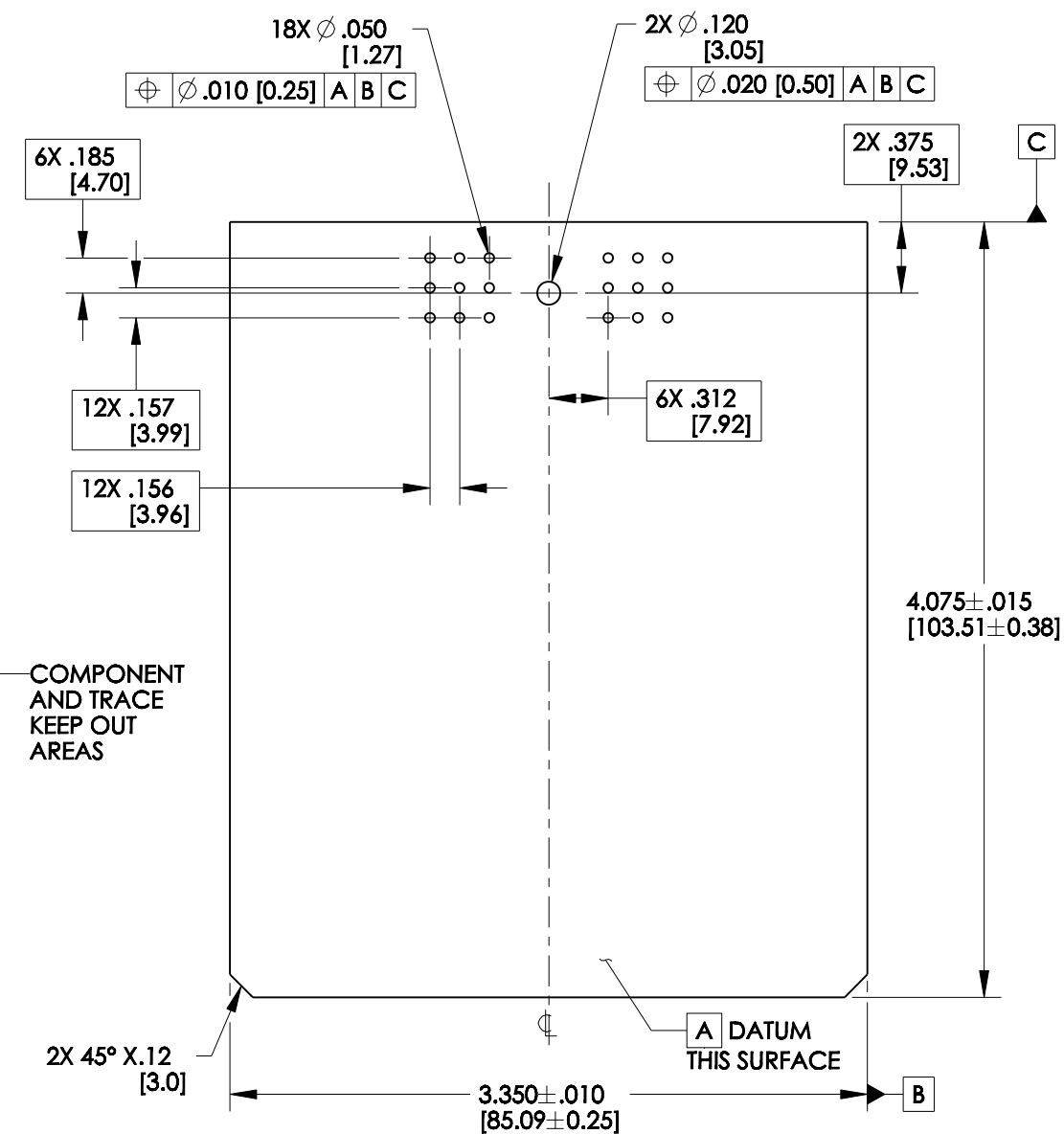
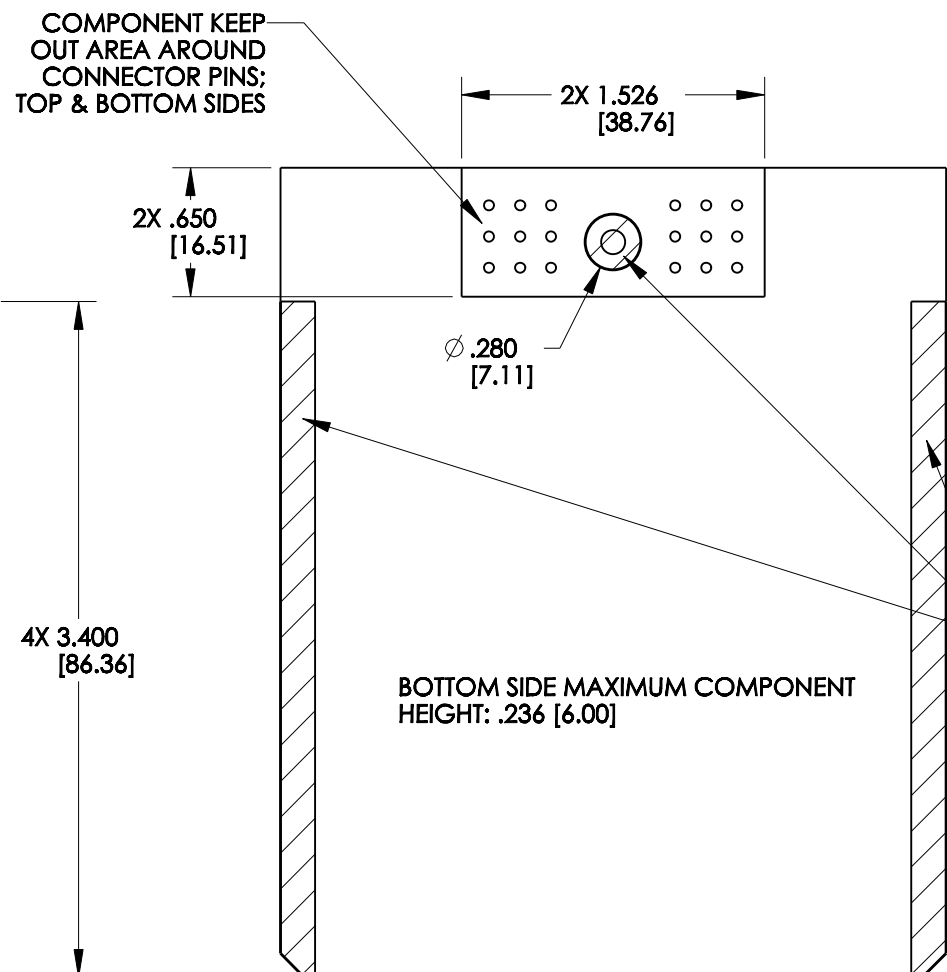
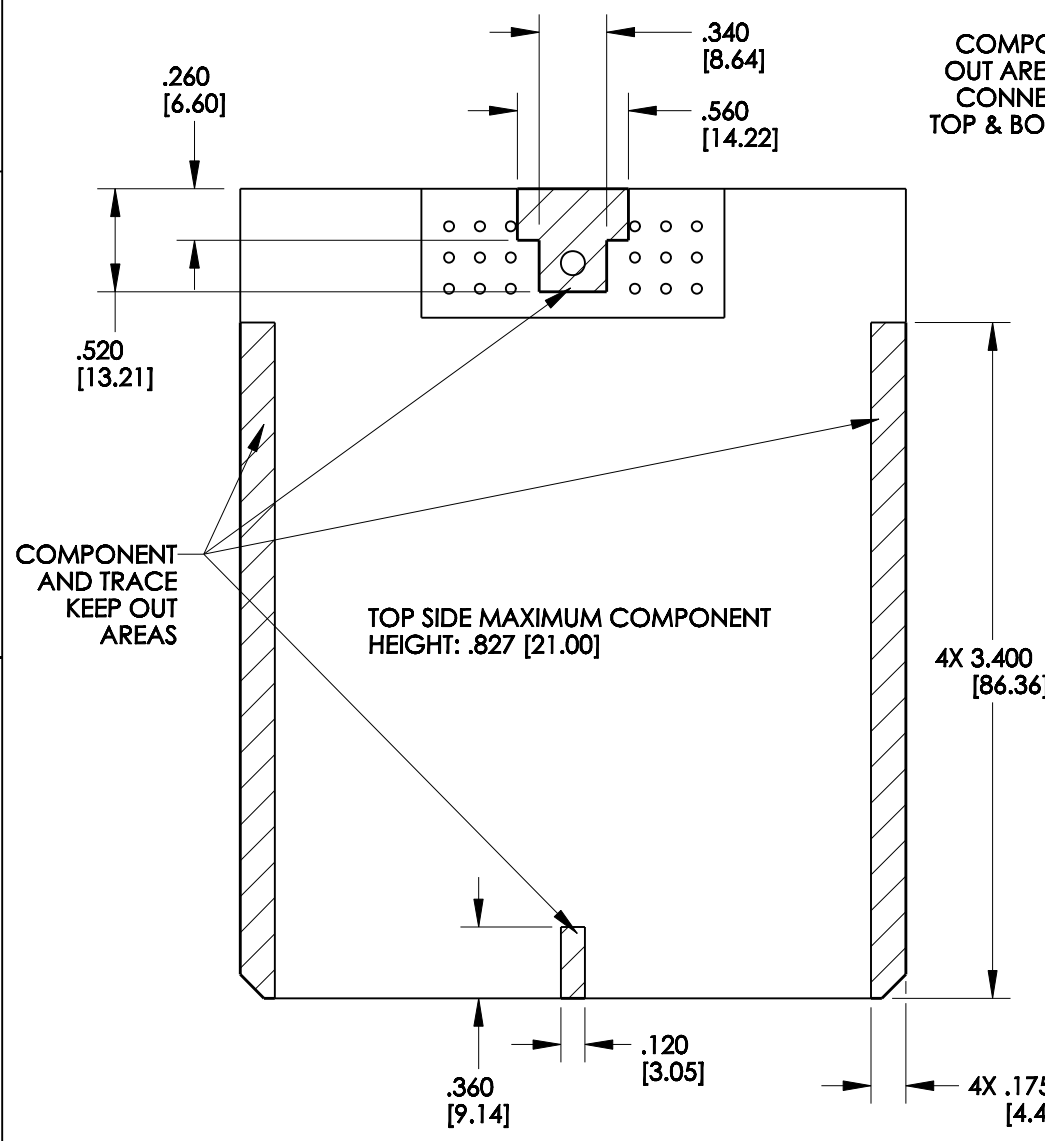

PCB TOP SIDE PIN AREA WITH FERRITES DETAIL

UNITS ENGLISH INCHES	CINCH		1700 FINLEY RD LOMBARD, IL. 60148
DO NOT SCALE DRAWING	TITLE 18-WAY HEADERS MODICE ME		
	PRO/E DRAWING		
<small>CONFIDENTIAL</small> <small>THIS DOCUMENT IS THE PROPERTY OF CINCH. NEITHER THIS DOCUMENT NOR ANY OF THE INFORMATION CONTAINED IN IT MAY BE DUPLICATED OR DISCLOSED WITHOUT PRIOR WRITTEN CONSENT OF CINCH. ©COPYRIGHT 2009 CINCH</small>	CAD FILE NUMBER 5810118038S	DRAWING NUMBER 5810118038S	REV A
	CAGE IDENT NO. 71785	SIZE B	SCALE 1:1
	SHEET 3 OF 3		