

For Immediate Assistance, Contact Your Local Salesperson

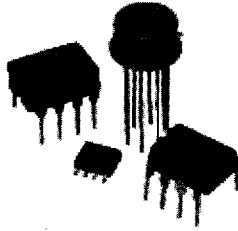

**OPA27
OPA37**

Ultra-Low Noise Precision OPERATIONAL AMPLIFIERS

FEATURES

- **LOW NOISE:** $3.8\text{nV}/\sqrt{\text{Hz}}$ max at 1kHz
- **LOW OFFSET:** $25\mu\text{V}$ max
- **LOW DRIFT:** $0.6\mu\text{V}/^\circ\text{C}$
- **HIGH OPEN-LOOP GAIN:** 120dB min
- **HIGH COMMON-MODE REJECTION:** 114dB min
- **HIGH POWER SUPPLY REJECTION:** 100dB min
- **FITS OP-07, OP-05, AD510, AD517 SOCKETS**

APPLICATIONS

- **PRECISION INSTRUMENTATION**
- **DATA ACQUISITION**
- **TEST EQUIPMENT**
- **PROFESSIONAL AUDIO EQUIPMENT**
- **TRANSDUCER AMPLIFIER**
- **RADIATION HARD EQUIPMENT**

DESCRIPTION

The OPA27/37 is an ultra-low noise, high precision monolithic operational amplifier.

Laser-trimmed thin-film resistors provide excellent long-term voltage offset stability and allow superior voltage offset compared to common zener-zap techniques.

A unique bias current cancellation circuit allows bias and offset current specifications to be met over the full -55°C to $+125^\circ\text{C}$ temperature range.

The OPA27 is internally compensated for unity-gain stability. The decompensated OPA37 requires a closed-loop gain ≥ 5 .

The Burr-Brown OPA27/37 is an improved replacement for the industry-standard OP-27/OP-37.

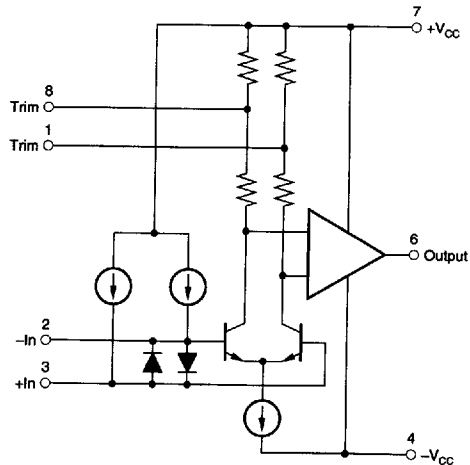

International Airport Industrial Park • Mailing Address: PO Box 11400 • Tucson, AZ 85734 • Street Address: 6730 S. Tucson Blvd. • Tucson, AZ 85706
Tel: (520) 746-1111 • Twx: 910-952-1111 • Cable: BBRCORP • Telex: 066-6481 • FAX: (520) 889-1510 • Immediate Product Info: (800) 548-6132

SPECIFICATIONS

ELECTRICAL

At $V_{CC} = \pm 15VDC$ and $T_A = +25^\circ C$ unless otherwise noted.

PARAMETER	CONDITIONS	OPA27/37A, OPA27/37E			OPA27/37B, OPA27/37F			OPA27/37C, OPA27/37G			UNITS	
		MIN	TYP	MAX	MIN	TYP	MAX	MIN	TYP	MAX		
INPUT												
NOISE⁽⁶⁾												
Voltage, $f_o = 10Hz$			3.1	5.5		3.5	5.5		3.8	8.0	nV/√Hz	
$f_o = 30Hz$			2.9	4.5		3.1	4.5		3.3	5.6	nV/√Hz	
$f_o = 1kHz$			2.7	3.8		3.0	3.8		3.2	4.5	nV/√Hz	
$f_b = 0.1Hz$ to 10Hz			0.07	0.18		0.08	0.18		0.09	0.25	μVp-p	
Current, ⁽¹⁾ $f_o = 10Hz$			1.7	4.0		1.7	4.0		1.7	1.7	pA/√Hz	
$f_o = 30Hz$			1.0	2.3		1.0	2.3		1.0	1.0	pA/√Hz	
$f_o = 1kHz$			0.4	0.6		0.4	0.6		0.4	0.6	pA/√Hz	
OFFSET VOLTAGE⁽²⁾												
Input Offset Voltage	$T_A \text{ MIN to } T_A \text{ MAX}$		±6	±25		±12	±60		±25	±100	μV	
Average Drift ⁽³⁾			±0.2	±0.6		±0.3	±1.3		±0.4	±1.8 ⁽⁶⁾	μV/°C	
Long Term Stability ⁽⁴⁾			0.2	1		0.3	1.5		0.4	2.0	μV/mo	
Supply Rejection	$\pm V_{CC} = 4$ to 18V $\pm V_{CC} = 4$ to 18V	100	134		100	125		94	120		dB	
BIAS CURRENT												
Input Bias Current			±11	±40		±13	±55		±15	±80	nA	
OFFSET CURRENT												
Input Offset Current			6	35		8	50		10	75	nA	
IMPEDANCE												
Common-Mode			3 2.5			2.5 2.5			2 2.5			GΩ pF
VOLTAGE RANGE												
Common-Mode Input Range		±11	±12.3		±11	±12.3		±11	±12.3		V	
Common-Mode Rejection	$V_{IN} = \pm 11VDC$	114	128		106	125		100	122		dB	
OPEN-LOOP GAIN, DC												
Open-Loop Voltage Gain	$R_L \geq 2k\Omega$ $R_L \geq 1k\Omega$	120	126		120	125		117	124		dB	
FREQUENCY RESPONSE												
Gain-Bandwidth Product ⁽⁵⁾	OPA27 OPA37	5	8		5	8		5 ⁽⁶⁾	8		MHz	
Slew Rate ⁽⁵⁾	$V_O = \pm 10V$, $R_L = 2k\Omega$	45	63		45	63		45 ⁽⁶⁾	63		MHz	
Settling Time, 0.01%	OPA27, G = +1	1.7	1.9		1.7	1.9		1.7 ⁽⁶⁾	1.9		V/μs	
	OPA37, G = +5	11	11.9		11	11.9		11 ⁽⁶⁾	11.9		V/μs	
	OPA27, G = +1		25			25			25		μs	
	OPA37, G = +5		25			25			25		μs	
RATED OUTPUT												
Voltage Output	$R_L \geq 2k\Omega$ $R_L \geq 600\Omega$	±12	±13.8		±12	±13.8		±12	±13.8		V	
Output Resistance	DC, Open Loop	±10	±12.8		±10	±12.8		±10	±12.8		V	
Short Circuit Current	$R_L = 0\Omega$		70	60		70	60		70	60 ⁽⁶⁾	mA	
			25			25			25		mA	
POWER SUPPLY												
Rated Voltage			±15			±15			±15		VDC	
Voltage Range,											VDC	
Derrated Performance											VDC	
Current, Quiescent	$I_O = 0mADC$	±4	3	±22	±4	3	±22	±4	3	±22	mA	
TEMPERATURE RANGE												
Specification											°C	
A, B, C (J, Z)		-55		+125	-55		+125	-55		+125	°C	
E, F (J, Z)		-25		+85	-25		+85	-40		+85	°C	
G (P, U, J, Z)											°C	
Operating											°C	
J, Z		-55		+125	-55		+125	-55		+125	°C	
P, U								-40		+85	°C	

OPA27/37
2
OPERATIONAL AMPLIFIERS

NOTES: (1) Measured with industry-standard noise test circuit (Figures 1 and 2). Due to errors introduced by this method, these current noise specifications should be used for comparison purposes only. (2) Offset voltage specifications on grades A and E are also guaranteed with units fully warmed up. Grades B, C, F, and G are measured with automatic test equipment after approximately 0.5 seconds from power turn-on. (3) Unrulled or rulled with 8kΩ to 20kΩ potentiometer. (4) Long-term voltage offset vs time trend line does not include warm-up drift. (5) Typical specification only on plastic package units. Slew rate varies on all units due to differing test methods. Minimum specification applies to open-loop test. (6) This parameter guaranteed by design.

For Immediate Assistance, Contact Your Local Salesperson

ELECTRICAL

At $V_{CC} = \pm 15\text{VDC}$ and $T_A = T_{MIN}$ to T_{MAX} unless otherwise noted.

PARAMETER	CONDITIONS	OPA27/37A, OPA27/37E			OPA27/37B, OPA27/37F			OPA27/37C, OPA27/37G			UNITS	
		MIN	TYP	MAX	MIN	TYP	MAX	MIN	TYP	MAX		
TEMPERATURE RANGE												
Specification Range A, B, C (J, Z) E, F (J, Z) G (P, U, J, Z)		-55 -25		+125 +85	-55 -25		+125 +85	-55 -40		+125 +85	°C °C °C	
INPUT												
OFFSET VOLTAGE ⁽¹⁾ Input Offset Voltage A, B, C E, F, G	$T_{A\ MIN}$ to $T_{A\ MAX}$		±24 ±17 ±0.2	±60 ±50 ±0.6		±45 ±33 ±0.3	±200 ±140 ±1.3		±60 ±48 ±0.4	±300 ±220 ⁽³⁾ ±1.8 ⁽³⁾	μV μV μV/°C	
Average Drift ⁽²⁾ Supply Rejection A, B, C E, F, G		$\pm V_{CC} = 4.5$ to 18V $\pm V_{CC} = 4.5$ to 18V	96 97	130 130		94 96	127 127		86 90 ⁽³⁾	122 122		dB dB
BIAS CURRENT Input Bias Current A, B, C E, F, G				±16 ±13	±60 ±60		±22 ±16	±95 ±95		±29 ±21	±150 ±150 ⁽³⁾	nA nA
OFFSET CURRENT Input Offset Current A, B, C E, F, G			23 12	50 50		25 14	85 85		35 20	135 135 ⁽³⁾	nA nA	
VOLTAGE RANGE Common-Mode Input Range A, B, C E, F, G Common-Mode Rejection A, B, C E, F, G	$V_{IN} = \pm 11\text{VDC}$		±10.3 ±10.5	±11.5 ±11.8		±10.3 ±10.5	±11.5 ±11.8		±10.3 ±10.5 ⁽³⁾	±11.5 ±11.8	V V	
			108 110	124 126		100 102	122 124		94 96 ⁽³⁾	120 122	dB dB	
OPEN-LOOP GAIN, DC												
Open-Loop Voltage Gain A, B, C E, F, G	$R_L \geq 2\text{k}\Omega$		116 118	121 123		114 117	120 122		110 113 ⁽³⁾	118 120	dB dB	
RATED OUTPUT												
Voltage Output A, B, C E, F, G Short Circuit Current	$R_L = 2\text{k}\Omega$ $V_O = 0\text{VDC}$		±11.5 ±11.7	±13.7 ±13.8 25		±11.0 ±11.4	±13.5 ±13.6 25		±10.5 ±11.0 ⁽³⁾	±13.3 ±13.4	V V mA	

NOTES: (1) Offset voltage specifications on grades A and E are also guaranteed with the units fully warmed up. Grades B, C, F, and G are measured with automatic test equipment after approximately 0.5s from power turn-on. (2) Unnullified or nulled with 8kΩ to 20kΩ potentiometer. (3) This parameter guaranteed by design in P-DIP, "P" package and SOIC "U" package.

ABSOLUTE MAXIMUM RATINGS

Supply Voltage	±22V
Internal Power Dissipation ⁽¹⁾	500mW
Input Voltage	±V _{CC}
Output Short-Circuit Duration ⁽²⁾	Indefinite
Differential Input Voltage ⁽³⁾	±0.7V
Differential Input Current ⁽³⁾	±25mA
Storage Temperature Range:	
J, Z	-65°C to +150°C
P, U	-55°C to +125°C
Operating Temperature Range:	
A, B, C, E, F, G (J, Z)	-55°C to +125°C
G (P, U)	-40°C to +85°C
Lead Temperature:	
J, Z, P (soldering, 10s)	+300°C
U (soldering, 3s)	+260°C

PACKAGE TYPE	θ_{JA}	UNITS
TO-99 (J)	150	°C/W
8-Pin Hermetic DIP (Z)	150	°C/W
8-Pin Plastic DIP (P)	100	°C/W
8-Pin SOIC (U)	160	°C/W

NOTES: (1) Maximum package power dissipation vs ambient temperature. (2) To common with $\pm V_{CC} = 15\text{V}$. (3) The inputs are protected by back-to-back diodes. Current limiting resistors are not used in order to achieve low noise. If differential input voltage exceeds ±0.7V, the input current should be limited to 25mA.

The information provided herein is believed to be reliable; however, BURR-BROWN assumes no responsibility for inaccuracies or omissions. BURR-BROWN assumes no responsibility for the use of this information, and all use of such information shall be entirely at the user's own risk. Prices and specifications are subject to change without notice. No patent rights or licenses to any of the circuits described herein are implied or granted to any third party. BURR-BROWN does not authorize or warrant any BURR-BROWN product for use in life support devices and/or systems.

CONNECTION DIAGRAMS

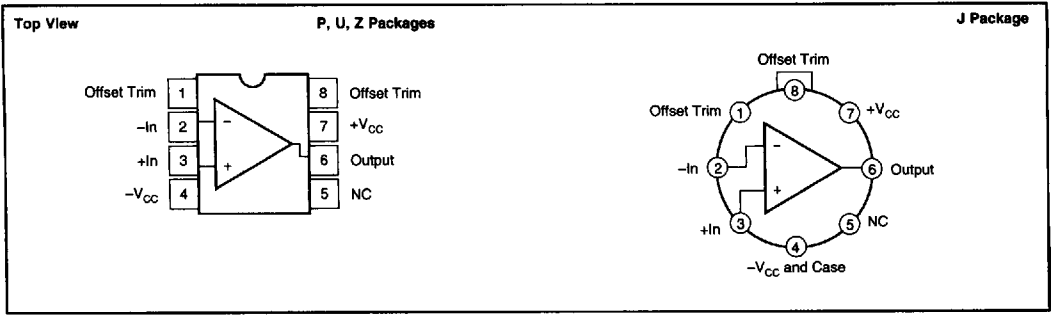

OPA27/37

2

OPERATIONAL AMPLIFIERS

ORDERING INFORMATION

MODEL (1)	PACKAGE	TEMPERATURE RANGE (°C)	OFFSET VOLTAGE MAX (μV), 25°C
OPA27AJ	TO-99	-55 to +125	±25
OPA27BJ	TO-99	-55 to +125	±60
OPA27CJ	TO-99	-55 to +125	±100
OPA27EJ	TO-99	-25 to +85	±25
OPA27FJ	TO-99	-25 to +85	±60
OPA27GJ	TO-99	-40 to +85	±100
OPA27AZ	Ceramic	-55 to +125	±25
OPA27BZ	Ceramic	-55 to +125	±60
OPA27CZ	Ceramic	-55 to +125	±100
OPA27EZ	Ceramic	-25 to +85	±25
OPA27FZ	Ceramic	-25 to +85	±60
OPA27GZ	Ceramic	-40 to +85	±100
OPA27GP	Plastic	-40 to +85	±100
OPA27GU(2)	SOIC	-40 to +85	±100

NOTE: (1) Packages and prices for OPA37 are same as for OPA27. (2) OPA27GU may be marked OPA27U. Likewise, OPA37GU may be marked OPA37U.

PACKAGE INFORMATION

MODEL	PACKAGE	PACKAGE DRAWING NUMBER(1)
OPA27AJ	TO-99	001
OPA27BJ	TO-99	001
OPA27CJ	TO-99	001
OPA27EJ	TO-99	001
OPA27FJ	TO-99	001
OPA27GJ	TO-99	001
OPA27AZ	Ceramic	001
OPA27BZ	Ceramic	161
OPA27CZ	Ceramic	161
OPA27DZ	Ceramic	161
OPA27EZ	Ceramic	161
OPA27FZ	Ceramic	161
OPA27GZ	Ceramic	161
OPA27GP	Plastic	006
OPA27GU	SOIC	182

NOTE: (1) For detailed drawing and dimension table, please see end of data sheet, or Appendix C of Burr-Brown IC Data Book.

For Immediate Assistance, Contact Your Local Salesperson

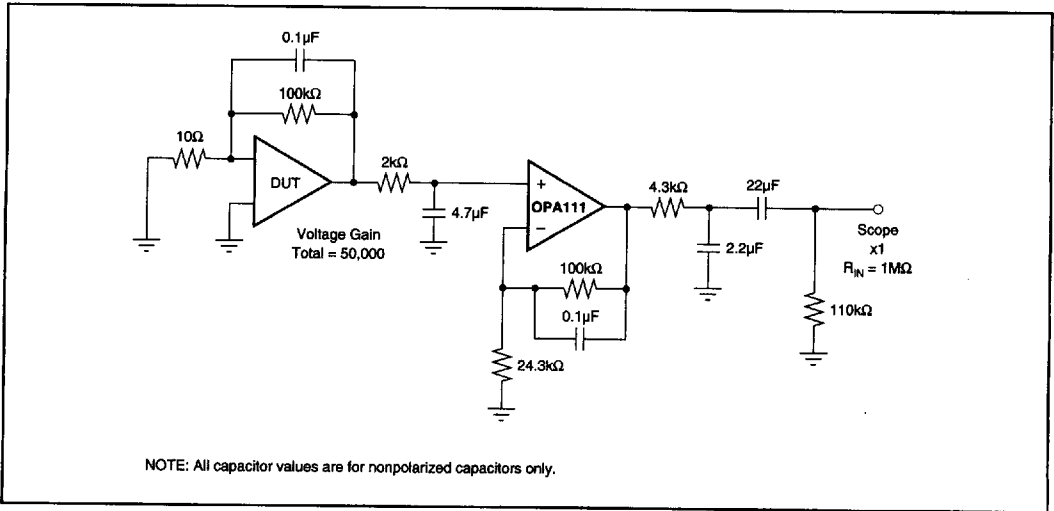

FIGURE 1. 0.1Hz to 10Hz Noise Test Circuit.

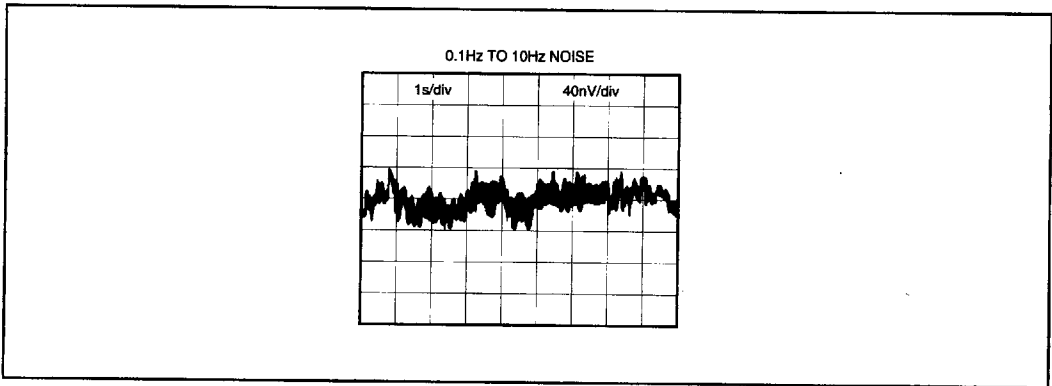
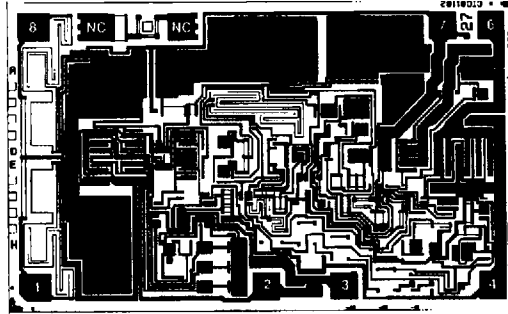

FIGURE 2. Low Frequency Noise.

Or, Call Customer Service at 1-800-548-6132 (USA Only)

DICE INFORMATION



OPA27 DIE TOPOGRAPHY

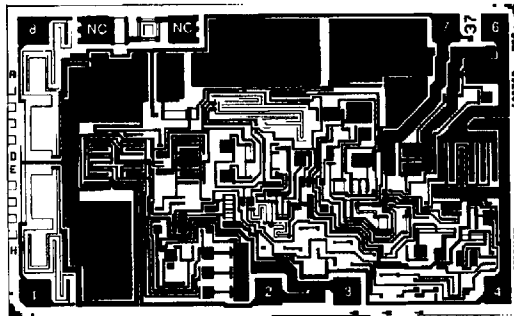

OPA37 DIE TOPOGRAPHY

PAD	FUNCTION	PAD	FUNCTION
1	Offset Trim	5	No Pad
2	-In	6	Output
3	+In	7	+V _{CC}
4	-V _{CC}	8	Offset Trim
		NC	No Connection

Substrate Bias: -V_{CC}

MECHANICAL INFORMATION

	MILS (0.001")	MILLIMETERS
Die Size	99 x 61 ±5	2.51 x 1.55 ±0.13
Die Thickness	20 ±3	0.51 ±0.08
Min. Pad Size	4 x 4	0.10 x 0.10
OPA27 Transistor Count		47
OPA37 Transistor Count		42
Backing		Gold

OPA27/37
2
OPERATIONAL AMPLIFIERS

For Immediate Assistance, Contact Your Local Salesperson

TYPICAL PERFORMANCE CURVES

$T_A = +25^\circ\text{C}$, $\pm V_{CC} = \pm 15\text{VDC}$ unless otherwise noted.

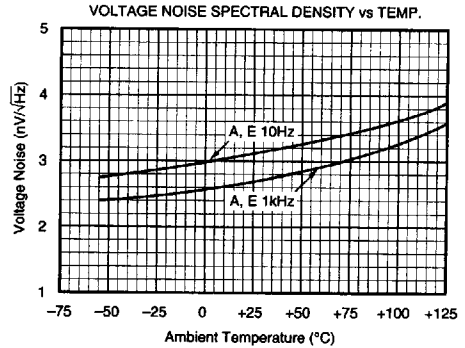
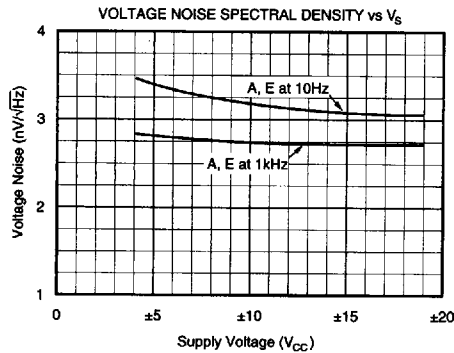
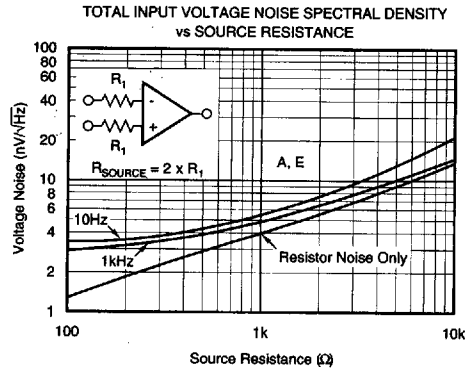
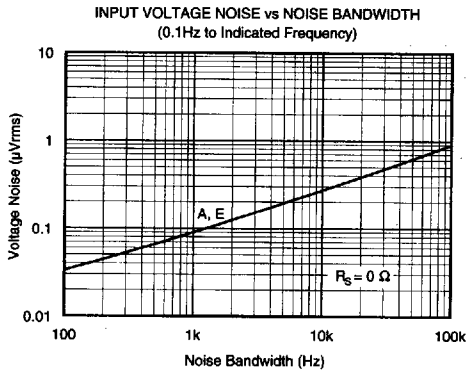
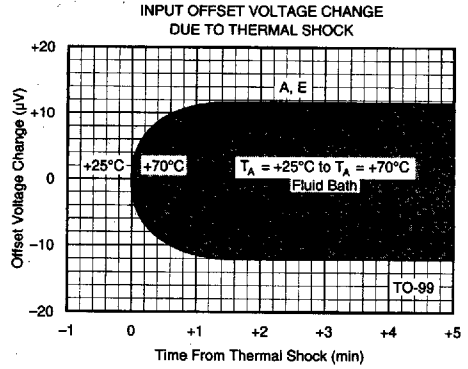
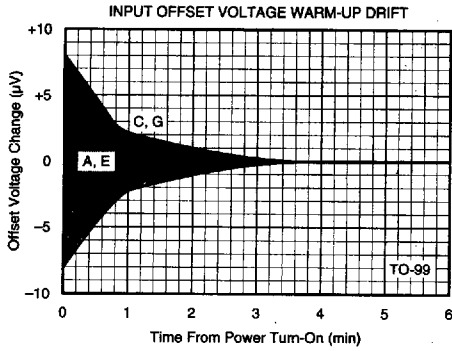

Or, Call Customer Service at 1-800-548-6132 (USA Only)

TYPICAL PERFORMANCE CURVES (CONT)

T_A = +25°C, ±V_{CC} = ±15VDC unless otherwise noted.

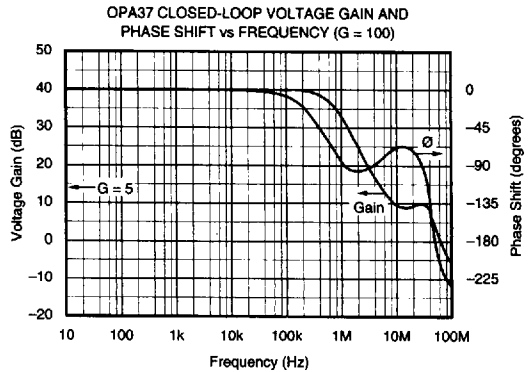
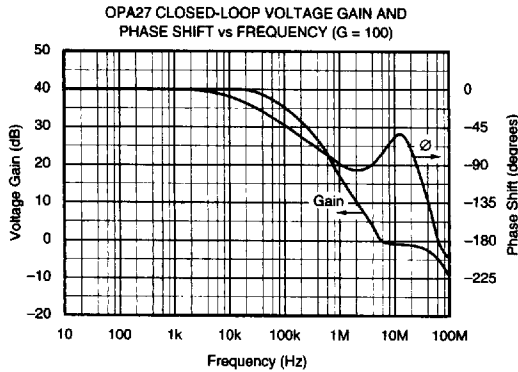
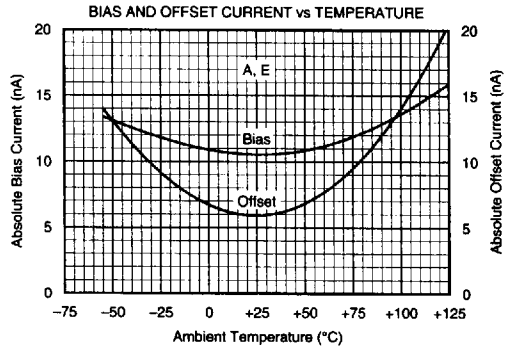
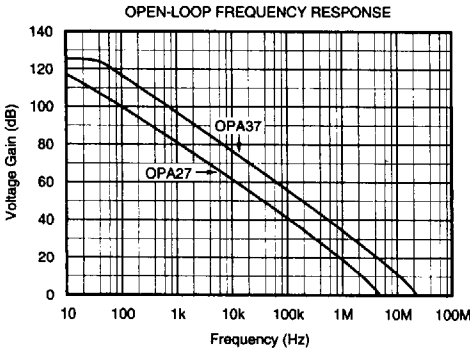
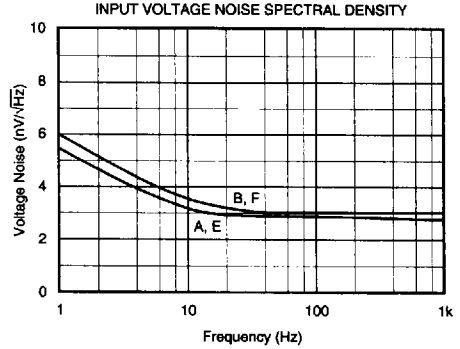
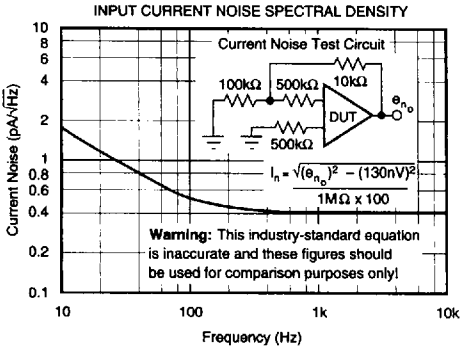

For Immediate Assistance, Contact Your Local Salesperson

TYPICAL PERFORMANCE CURVES (CONT)

T_A = +25°C, ±V_{CC} = ±15VDC unless otherwise noted.

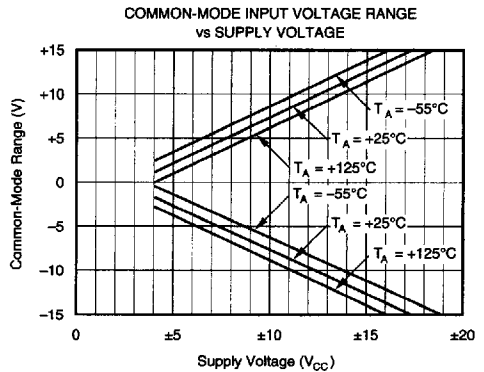
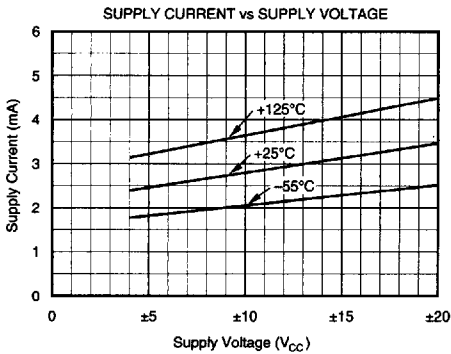
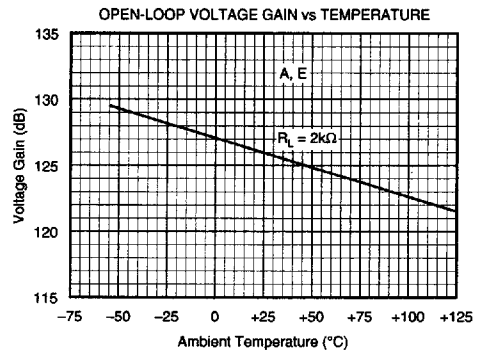
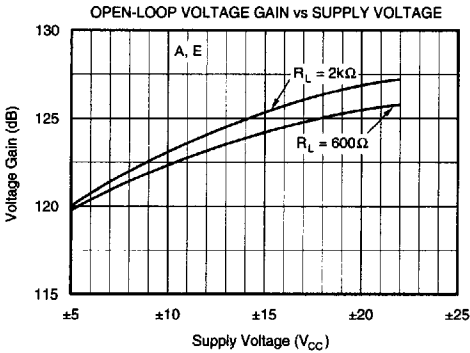
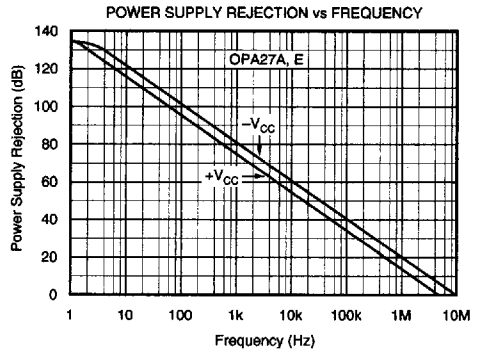
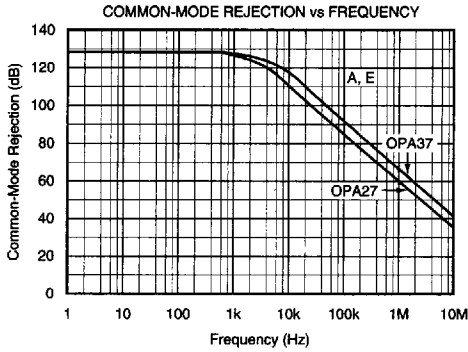

Or, Call Customer Service at 1-800-548-6132 (USA Only)

TYPICAL PERFORMANCE CURVES (CONT)

$T_A = +25^\circ\text{C}$, $\pm V_{CC} = \pm 15\text{VDC}$ unless otherwise noted.

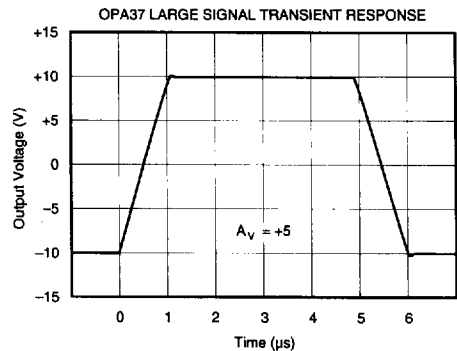
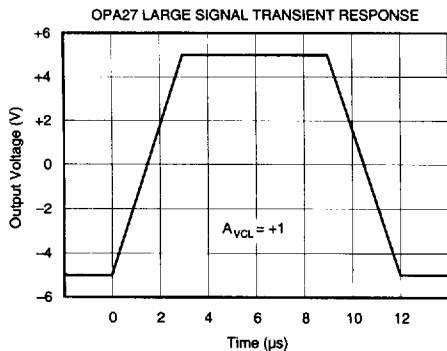
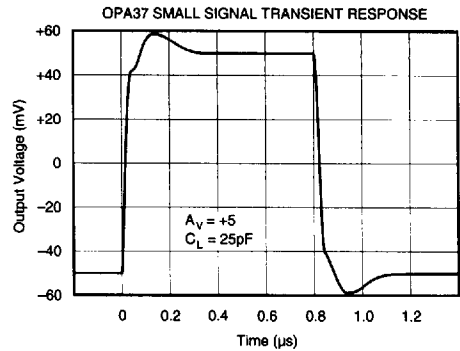
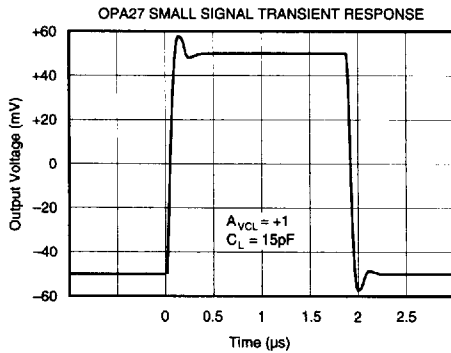

APPLICATIONS INFORMATION

OFFSET VOLTAGE ADJUSTMENT

The OPA27/37 offset voltage is laser-trimmed and will require no further trim for most applications. Offset voltage drift will not be degraded when the input offset is nulled with a $10\text{k}\Omega$ trim potentiometer. Other potentiometer values from $1\text{k}\Omega$ to $1\text{M}\Omega$ can be used but V_{OS} drift will be degraded by an additional 0.1 to $0.2\mu\text{V}/^\circ\text{C}$. Nulling large system offsets by use of the offset trim adjust will degrade drift performance by approximately $3.3\mu\text{V}/^\circ\text{C}$ per millivolt of offset. Large system offsets can be nulled without drift degradation by input summing.

The conventional offset voltage trim circuit is shown in Figure 3. For trimming very small offsets, the higher resolution circuit shown in Figure 4 is recommended.

The OPA27/37 can replace 741-type operational amplifiers by removing or modifying the trim circuit.

THERMOELECTRIC POTENTIALS

The OPA27/37 is laser-trimmed to microvolt-level input offset voltage and for very low input offset voltage drift.

Careful layout and circuit design techniques are necessary to prevent offset and drift errors from external thermoelectric potentials. Dissimilar metal junctions can generate small EMFs if care is not taken to eliminate either their sources (lead-to-PC, wiring, etc.) or their temperature difference. See Figure 11.

Short, direct mounting of the OPA27/37 with close spacing of the input pins is highly recommended. Poor layout can result in circuit drifts and offsets which are an order of magnitude greater than the operational amplifier alone.

For Immediate Assistance, Contact Your Local Salesperson

NOISE: BIPOLAR VERSUS FET

Low-noise circuit design requires careful analysis of all noise sources. External noise sources can dominate in many cases, so consider the effect of source resistance on overall operational amplifier noise performance. At low source impedances, the lower voltage noise of a bipolar operational amplifier is superior, but at higher impedances the high current noise of a bipolar amplifier becomes a serious liability. Above about 15kΩ the Burr-Brown OPA111 low-noise FET operational amplifier is recommended for lower total noise than the OPA27 (see Figure 5).

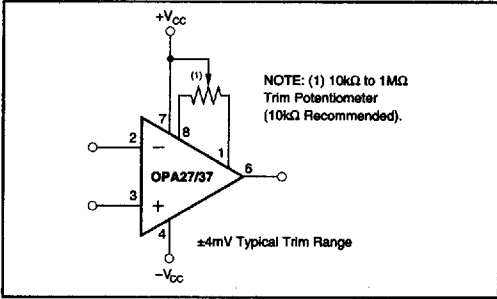

FIGURE 3. Offset Voltage Trim.

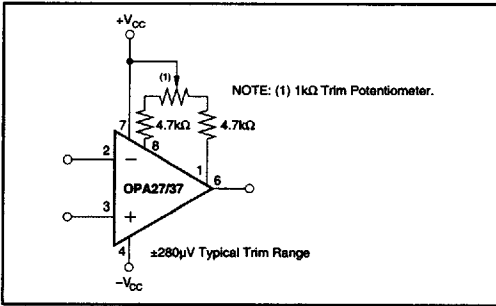

FIGURE 4. High Resolution Offset Voltage Trim.

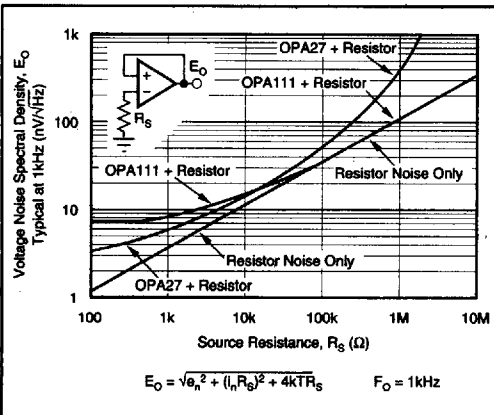

FIGURE 5. Voltage Noise Spectral Density Versus Source Resistance.

COMPENSATION

Although internally compensated for unity-gain stability, the OPA27 may require a small capacitor in parallel with a feedback resistor (R_f) which is greater than 2kΩ. This capacitor will compensate the pole generated by R_f and C_{IN} and eliminate peaking or oscillation.

INPUT PROTECTION

Back-to-back diodes are used for input protection on the OPA27/37. Exceeding a few hundred millivolts differential input signal will cause current to flow and without external current limiting resistors the input will be destroyed.

Accidental static discharge as well as high current can damage the amplifier's input circuit. Although the unit may still be functional, important parameters such as input offset voltage, drift, and noise may be permanently damaged as will any precision operational amplifier subjected to this abuse.

Transient conditions can cause feedthrough due to the amplifier's finite slew rate. When using the OP-27 as a unity-gain buffer (follower) a feedback resistor of 1kΩ is recommended (see Figure 6).

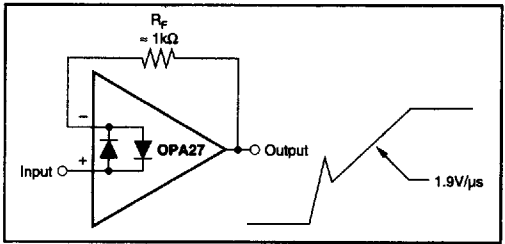

FIGURE 6. Pulsed Operation.

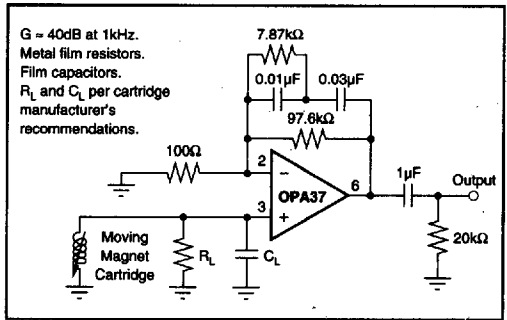

FIGURE 7. Low-Noise RIAA Preamplifier.

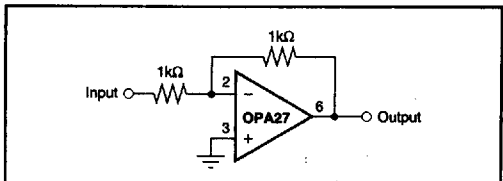

FIGURE 8. Unity-Gain Inverting Amplifier.

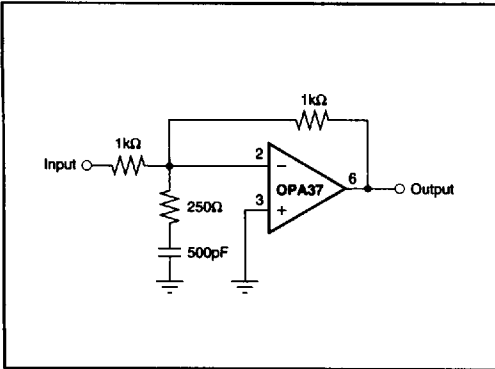

FIGURE 9. High Slew Rate Unity-Gain Inverting Amplifier.

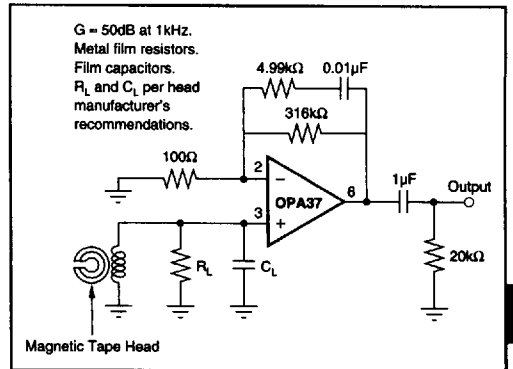

FIGURE 10. NAB Tape Head Preamplifier.

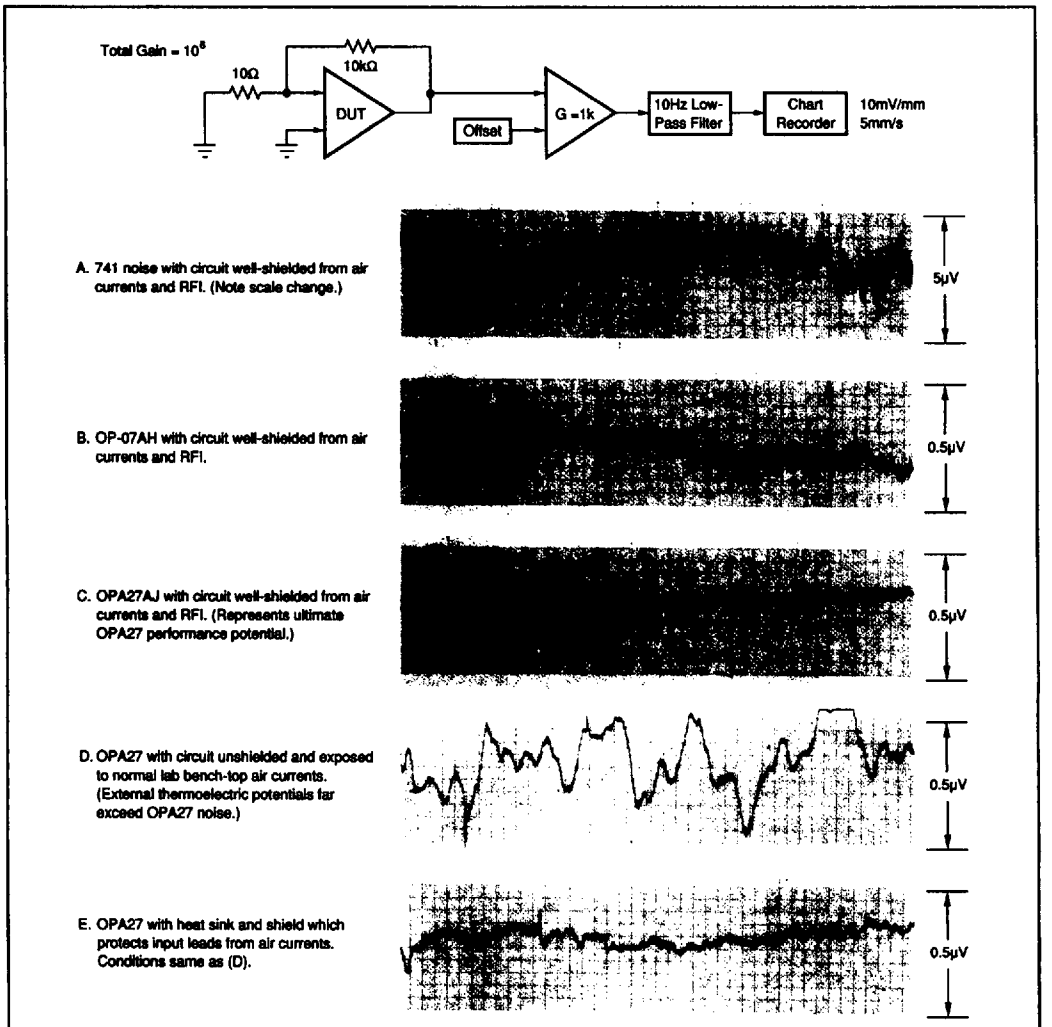

FIGURE 11. Low Frequency Noise Comparison.

For Immediate Assistance, Contact Your Local Salesperson

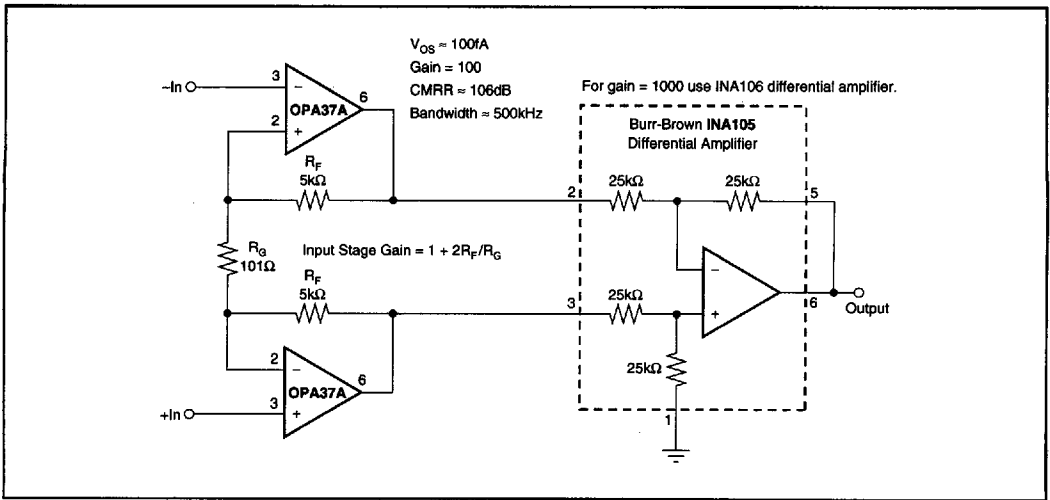

FIGURE 12. Low Noise Instrumentation Amplifier.

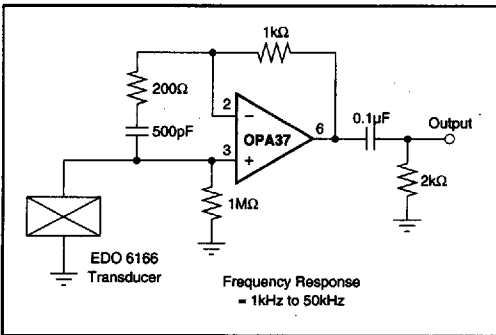

FIGURE 13. Hydrophone Preamplifier.

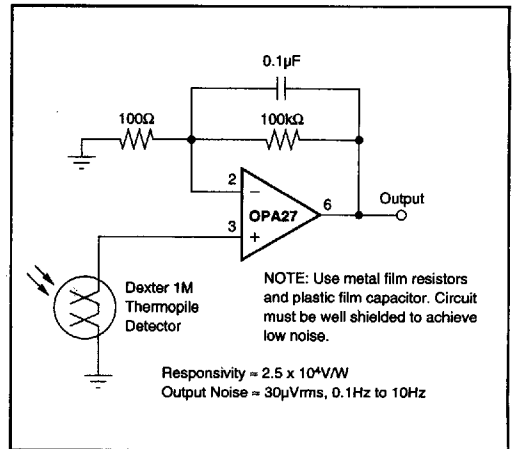

FIGURE 14. Long-Wavelength Infrared Detector Amplifier.

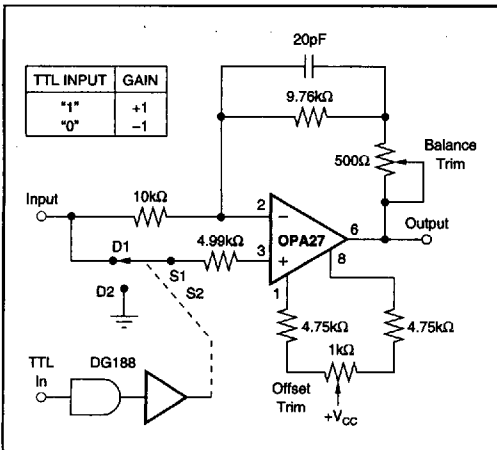

FIGURE 15. High Performance Synchronous Demodulator.

Or, Call Customer Service at 1-800-548-6132 (USA Only)

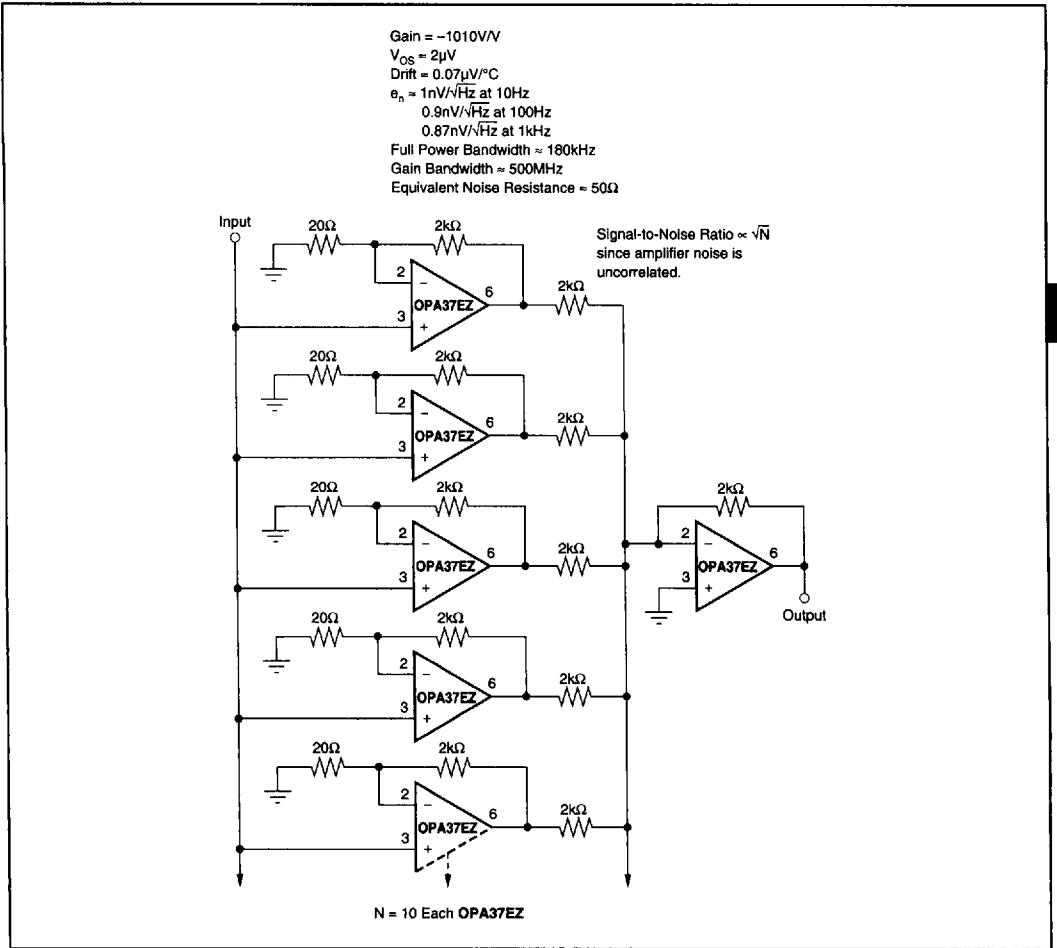

FIGURE 16. Ultra-Low Noise "N" Stage Parallel Amplifier.

For Immediate Assistance, Contact Your Local Salesperson

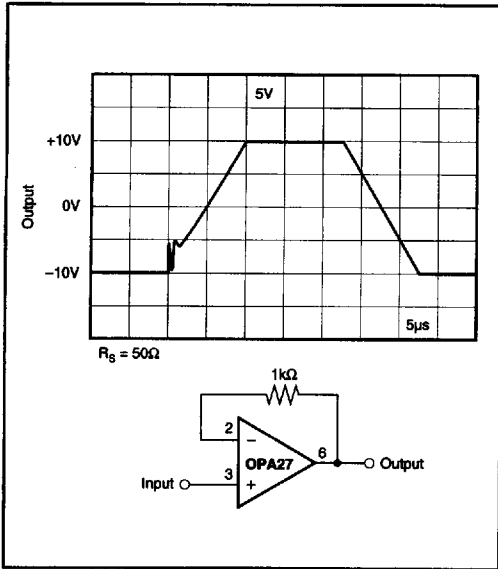

FIGURE 17. Unity-Gain Buffer.

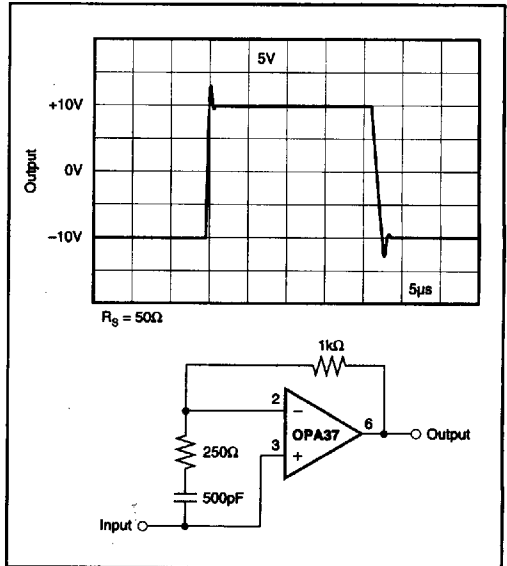

FIGURE 18. High Slew Rate Unity-Gain Buffer.

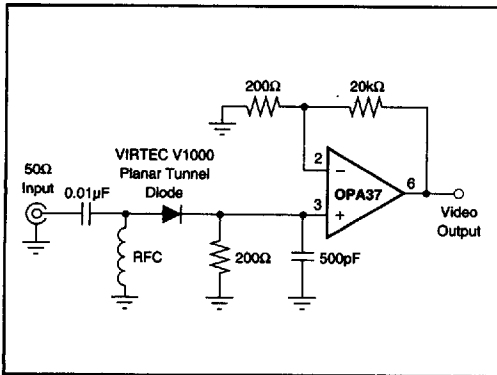

FIGURE 19. RF Detector and Video Amplifier.

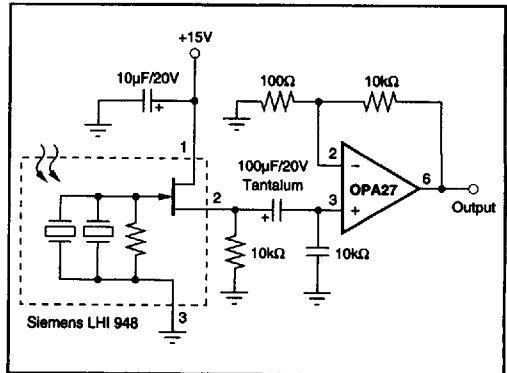

FIGURE 20. Balanced Pyroelectric Infrared Detector.

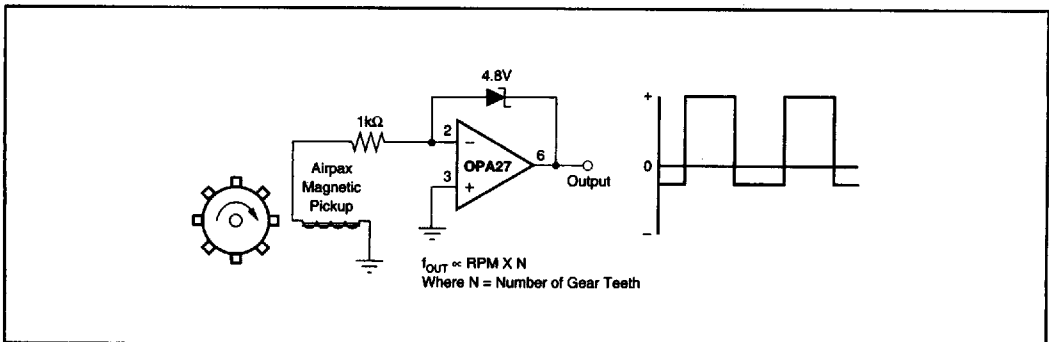

FIGURE 21. Magnetic Tachometer.