



REF101

## Precision VOLTAGE REFERENCE

### FEATURES

- +10.00V OUTPUT
- HIGH ACCURACY:  $\pm 0.005V$
- VERY LOW DRIFT: 1ppm/ $^{\circ}C$  max
- EXCELLENT STABILITY: 50ppm/1000hrs
- LOW NOISE: 6 $\mu V$ p-p typ, 0.1Hz to 10Hz
- WIDE SUPPLY RANGE: Up to 35V
- LOW QUIESCENT CURRENT: 6mA max
- USEFUL MATCHED RESISTOR PAIR INCLUDED

### APPLICATIONS

- PRECISION CALIBRATED VOLTAGE STANDARD
- TRANSDUCER EXCITATION
- D/A AND A/D CONVERTER REFERENCE
- PRECISION CURRENT REFERENCE
- ACCURATE COMPARATOR THRESHOLD REFERENCE
- DIGITAL VOLTMETERS
- TEST EQUIPMENT

### DESCRIPTION

The REF101 is a precision voltage reference which provides a +10.00V output. The drift is laser-trimmed to 1ppm/ $^{\circ}C$  max (KM grade) over the full specification range. This is in contrast to some references which guarantee drift over a limited portion of their specification temperature range. The REF101 achieves its precision without a heater. This results in low quiescent current (4.5mA typ), fast warm-up (1ms to 0.1%), excellent stability (50ppm/1000hrs typ), and low noise (25 $\mu V$ p-p max, 0.1Hz to 10Hz).

The output can be adjusted with minimal effect on drift or stability. Additionally, the REF101 contains a matched pair of user-accessible precision 20k $\Omega$  resistors which are useful in a variety of applications. Single supply operation over 13.5V to 35V supply range and excellent overall specifications make the REF101 an ideal choice for the most demanding applications such as precision system standards, D/A and A/D references, transducer excitation etc.

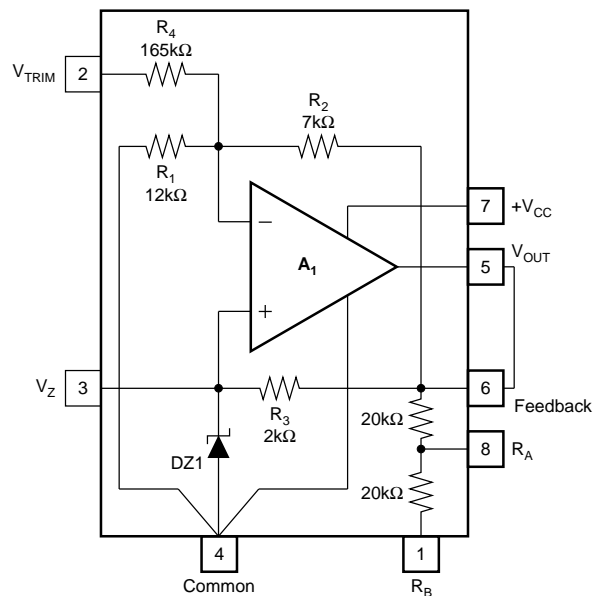

# SPECIFICATIONS

## ELECTRICAL

At  $T_A = +25^\circ\text{C}$  and +15VDC power supply, unless otherwise noted.

PARAMETER	CONDITIONS	REF101JM, KM, RM, SM			UNITS
		MIN	TYP	MAX	
<b>OUTPUT VOLTAGE</b>					
Initial	$T_A = +25^\circ\text{C}$	9.995	10.000	10.005	V
Trim Range <sup>(1)</sup>		-0.100		+0.250	V
vs Temperature <sup>(2)</sup>					
KM	$0^\circ\text{C}$ to $+70^\circ\text{C}$			1	ppm/ $^\circ\text{C}$
JM	$0^\circ\text{C}$ to $+70^\circ\text{C}$			2	ppm/ $^\circ\text{C}$
SM	$-55^\circ\text{C}$ to $+125^\circ\text{C}$			3	ppm/ $^\circ\text{C}$
RM	$-55^\circ\text{C}$ to $+125^\circ\text{C}$			6	ppm/ $^\circ\text{C}$
vs Supply (line regulation)	$V_{CC} = 13.5$ to $35\text{V}$		0.001	0.002	%/V
vs Output Current					
(load regulation)	$I_L = 0$ to $\pm 10\text{mA}$		0.001	0.002	%/mA
vs Time	$T_A = +25^\circ\text{C}$		50		ppm/1000hrs
<b>NOISE</b>	0.1Hz to 10Hz		6	25	$\mu\text{Vp-p}$
<b>OUTPUT CURRENT</b>	Source or Sink	$\pm 10$			mA
<b>INPUT VOLTAGE RANGE</b>		13.5		35	V
<b>QUIESCENT CURRENT</b>	$I_{OUT} = 0$		4.5	6	mA
<b>WARM-UP TIME</b>	To 0.1%		10		$\mu\text{s}$
<b>UNCOMMITTED RESISTORS</b>					
Resistance			20		k $\Omega$
Match			$\pm 0.01$	$\pm 0.05$	%
TCR			50		ppm/ $^\circ\text{C}$
TCR Tracking			2		ppm/ $^\circ\text{C}$
<b>TEMPERATURE RANGE</b>					
Specification			0	+70	$^\circ\text{C}$
JM, KM			-55	+125	$^\circ\text{C}$
Operating					
JM, KM			-25	+85	$^\circ\text{C}$
RM, SM			-55	+125	$^\circ\text{C}$
Storage			-65	+125	$^\circ\text{C}$

NOTES : (1) Trimming the offset voltage will affect the drift slightly. See Installation and Operating Instructions for details. (2) The "box method" is used to specify output voltage drift vs temperature. See the Discussion of Performance section.

## ORDERING INFORMATION

MODEL	PACKAGE	TEMPERATURE RANGE	MAX DRIFT (ppm/ $^\circ\text{C}$ )
REF101JM	Metal TO-99	$0^\circ\text{C}$ to $+70^\circ\text{C}$	2
REF101KM	Metal TO-99	$0^\circ\text{C}$ to $+70^\circ\text{C}$	1
REF101RM	Metal TO-99	$-55^\circ\text{C}$ to $+125^\circ\text{C}$	6
REF101SM	Metal TO-99	$-55^\circ\text{C}$ to $+125^\circ\text{C}$	3

## PACKAGE INFORMATION

MODEL	PACKAGE	PACKAGE DRAWING NUMBER <sup>(1)</sup>
REF101JM	Metal TO-99	001
REF101KM	Metal TO-99	001
REF101RM	Metal TO-99	001
REF101SM	Metal TO-99	001

NOTE: (1) For detailed drawing and dimension table, please see end of data sheet, or Appendix D of Burr-Brown IC Data Book.

## ABSOLUTE MAXIMUM RATINGS

Input Voltage .....	40V
Power Dissipation at $+25^\circ\text{C}$ .....	200mW
Operating Temperature Range	
JM, KM .....	$-25^\circ\text{C}$ to $+85^\circ\text{C}$
RM, SM .....	$-55^\circ\text{C}$ to $+125^\circ\text{C}$
Storage Temperature Range .....	$-65^\circ\text{C}$ to $+125^\circ\text{C}$
Lead Temperature (soldering, 10s) .....	$+300^\circ\text{C}$
Short-Circuit Protection at $+25^\circ\text{C}$	
To Common or +15VDC .....	Continuous

## PIN CONFIGURATION

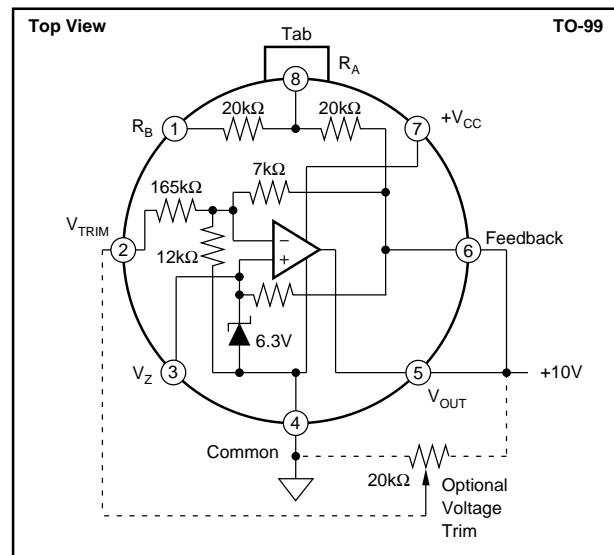

## NOISE TEST CIRCUIT

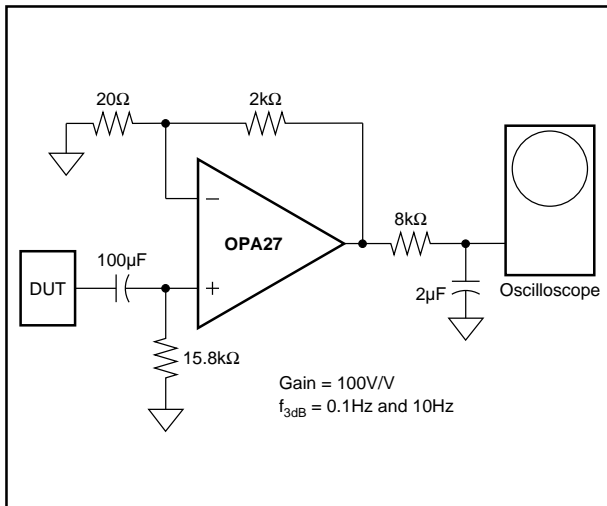

## OPTIONAL OUTPUT VOLTAGE FINE ADJUSTMENT CIRCUIT

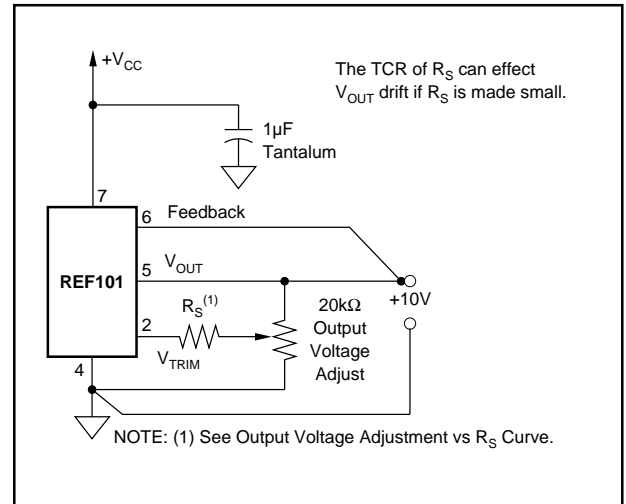

## TYPICAL PERFORMANCE CURVES

At  $T_A = +25^\circ\text{C}$  and +15VDC power supply, unless otherwise noted.

TYPICAL REF101 NOISE

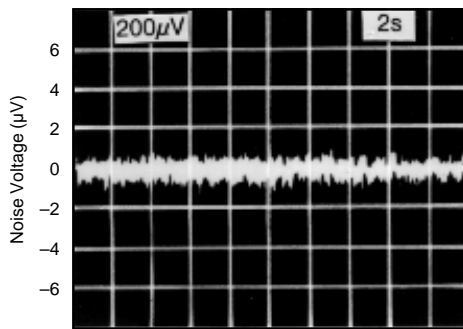

Low Frequency Noise  
(see Noise Test Circuit)

TYPICAL HEATED ZENER NOISE

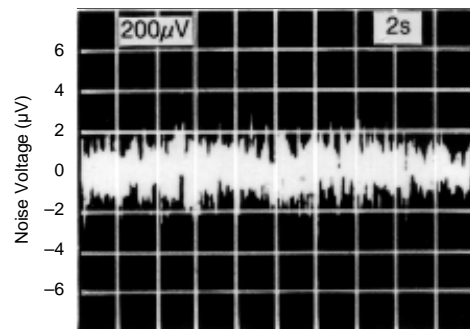

Low Frequency Noise  
(see Noise Test Circuit)

TYPICAL BANDGAP REFERENCE NOISE

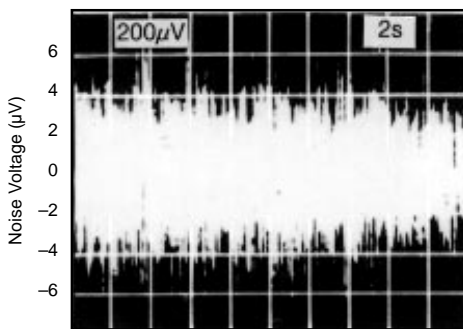

Low Frequency Noise  
(see Noise Test Circuit)

POWER TURN-ON RESPONSE

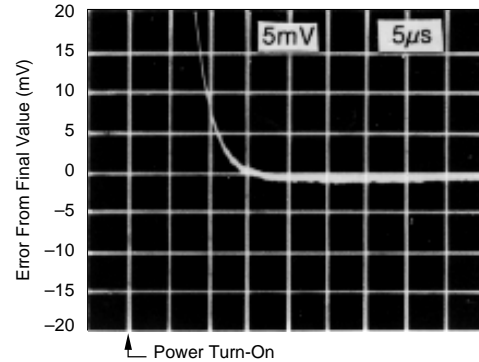

↑ Power Turn-On

# TYPICAL PERFORMANCE CURVES (CONT)

At  $T_A = +25^\circ\text{C}$  and +15VDC power supply, unless otherwise noted.

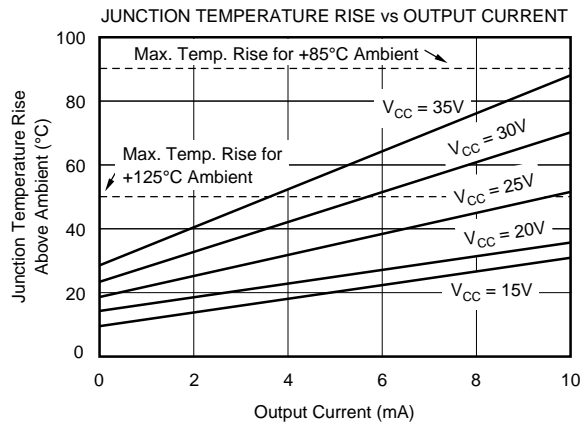
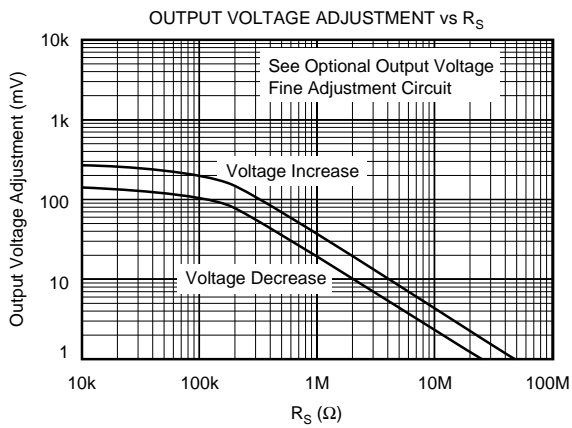
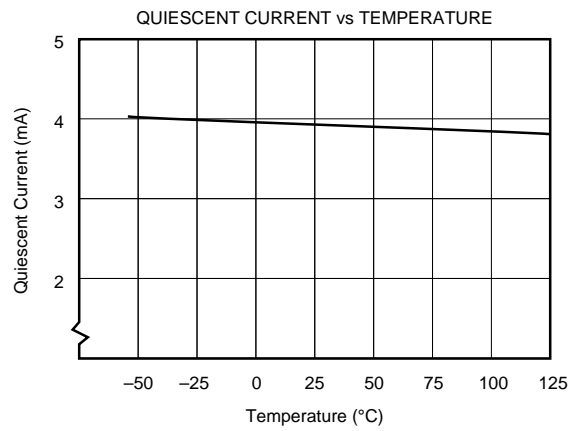
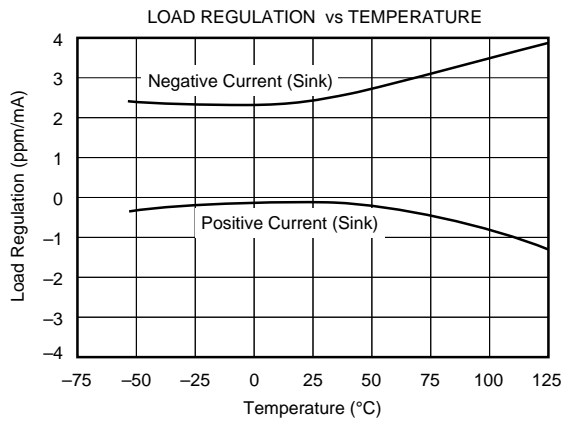
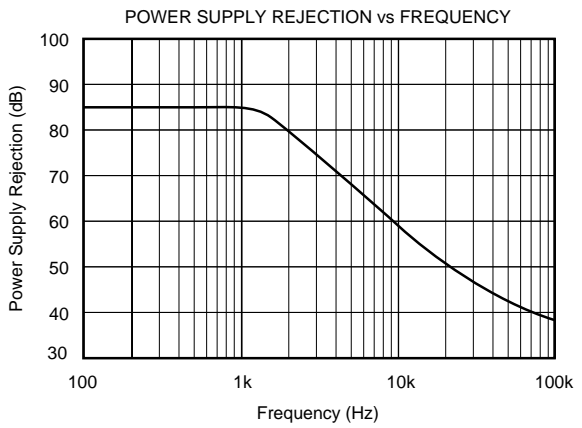
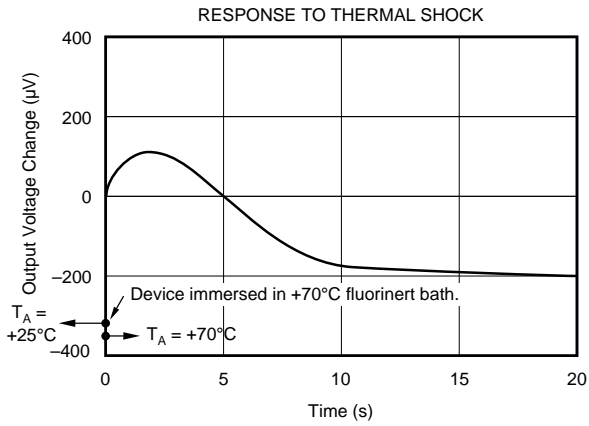

## THEORY OF OPERATION

The following discussion refers to the diagram on the first page.

In operation, approximately 6.3V is applied to the noninverting input of op amp A<sub>1</sub> by zener diode DZ<sub>1</sub>. This voltage is amplified by A<sub>1</sub> to produce the 10.00V output. The gain is determined by R<sub>1</sub> and R<sub>2</sub>:  $G = (R_1 + R_2)/R_1$ . R<sub>1</sub> and R<sub>2</sub> are actively laser-trimmed to produce an exact 10.00V output. The zener operating current is derived from the regulated output voltage through R<sub>3</sub>. This feedback arrangement provides closely regulated zener current. R<sub>3</sub> is actively laser-trimmed to set the zener current to a level which results in low drift at the output of A<sub>1</sub>. The adjustment of output voltage and zener current is interactive and several iterations may be used to achieve the desired results. R<sub>4</sub> allows user-trimming of the output voltage by providing for a small external adjustment of amplifier gain. Since the TCR of R<sub>4</sub> closely matches the TCR of the gain setting resistors, the voltage trim has minimal effect on the drift of the reference.

## DISCUSSION OF PERFORMANCE

The REF101 is designed for applications requiring a precision voltage reference where both the initial value at room temperature and the drift over temperature are of importance to the user. Two basic methods of specifying voltage reference drift versus temperature are in common usage in the industry—the “butterfly method” and the “box method”. Neither of these methods is entirely satisfactory in cases where the drift versus temperature is relatively nonlinear as is the case with most voltage references. The REF101 is specified with the more commonly used box method. The “box” is formed by the high and low specification temperatures and a diagonal, the slope of which is equal to the maximum specified drift.

For the REF101, each J and K unit is tested at temperatures of 0°C, +25°C, +50°C, and +70°C, and each R and S unit is tested at -55°C, -25°C, 0°C, +25°C, +50°C, +75°C, +100°C and +125°C. The minimum and maximum test voltages must meet this condition.

$$\left[ \frac{(V_{OUT\ MAX} - V_{OUT\ MIN})/10V}{T_{HIGH} - T_{LOW}} \right] \times 10^6 \leq \text{drift specification}$$

This assures the user that the variations of output voltage that occur as the temperature changes within the specification range T<sub>LOW</sub> to T<sub>HIGH</sub> will be contained within a box whose diagonal has a slope equal to the maximum specified drift. Since the shape of the actual drift curve is not known, the vertical position of the box is not exactly known either. It is, however, bounded by V<sub>UPPER BOUND</sub> and V<sub>LOWER BOUND</sub> (see Figure 1).

Figure 1 uses the REF101KM as an example. It has a drift specification of 1ppm/°C maximum and a specification

temperature range of 0°C to +70°C. The “box” height (V<sub>1</sub> to V<sub>2</sub>) is 700μV and upper bound and lower bound voltages are a maximum of 700μV away from the voltage at +25°C.

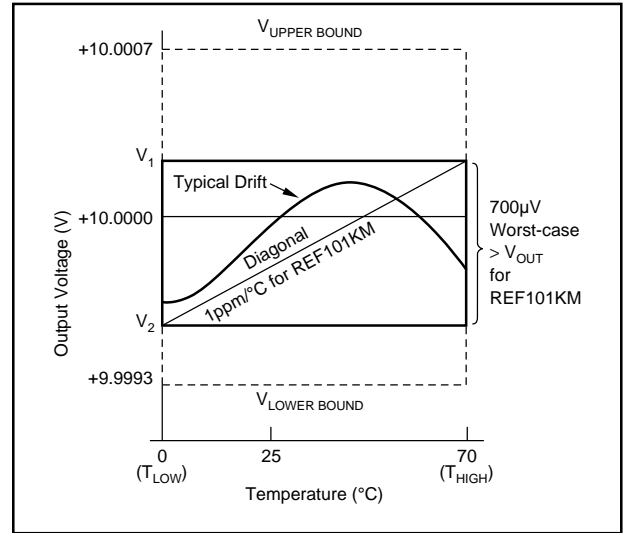

FIGURE 1. REF101KM Output Voltage Drift.

## INSTALLATION AND OPERATING INSTRUCTIONS

### BASIC CIRCUIT CONNECTION

Figure 2 shows the proper connection of the REF101. To achieve the specified performance, pay careful attention to layout. A low resistance star configuration will reduce voltage errors, noise pickup, and noise coupled from the power supply. Commons should be connected as indicated being sure to minimize interconnection resistances.

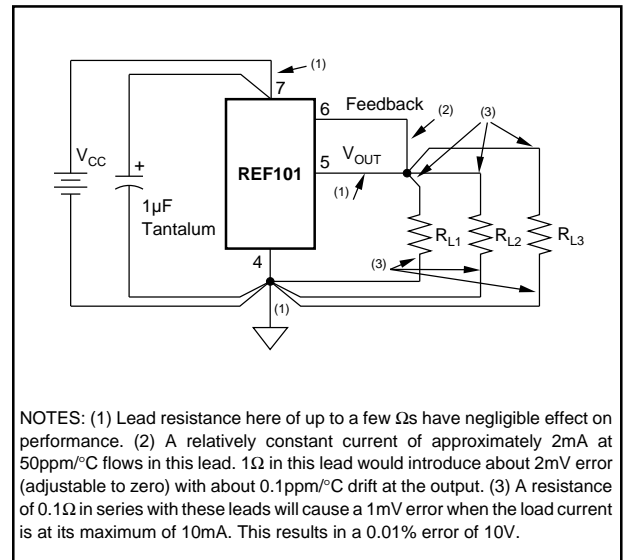

FIGURE 2. REF101 Basic Circuit Connection.

## OPTIONAL OUTPUT VOLTAGE ADJUSTMENT

Optional output voltage adjustment circuits are shown in Figures 3 and 4. Trimming the output voltage will change the voltage drift by approximately 0.01 ppm/°C per mV of trimmed voltage. In the circuit in Figure 3, any mismatch in TCR between the two sections of the potentiometer will also affect drift, but the effect of the  $\Delta TCR$  is reduced by a factor of 40 by the internal resistor divider. A high quality potentiometer, with good mechanical stability, such as a cermet, should be used. The circuit in Figure 3 has a range of approximately +250mV to -100mV. The circuit in Figure 4 has less range but provides higher resolution. The mismatch in TCR between  $R_S$  and the internal resistors can introduce some slight drift. This effect is minimized if  $R_S$  is kept significantly larger than the 165k $\Omega$  internal resistor. A TCR of 100ppm/°C is normally sufficient.

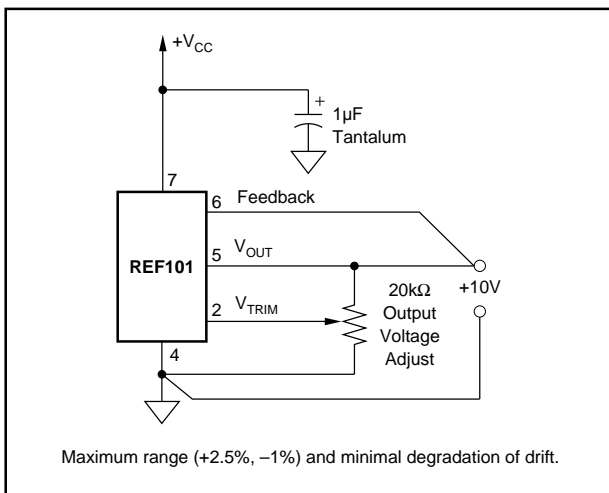

FIGURE 3. REF101 Optional Output Voltage Adjustment.

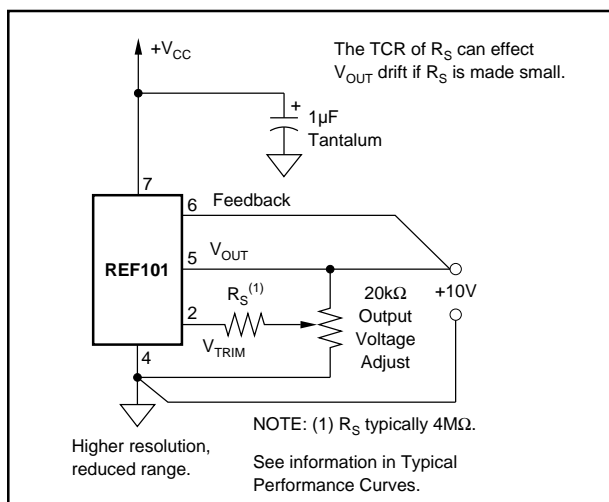

FIGURE 4. REF101 Optional Output Voltage Fine Adjust.

## APPLICATION INFORMATION

High accuracy, extremely-low drift, and small size make the REF101 ideal for demanding instrumentation and system voltage reference applications. Since no heater is required, low power supply current designs are readily achievable. Also the REF101 has lower output noise and much faster warm-up times (1ms to 0.1%) than heated references, permitting high precision without extra power from additional supplies. It should be considered that operating any integrated circuit at an elevated temperature will reduce its MTTF.

A variety of application circuits are shown in Figures 5 through 19.

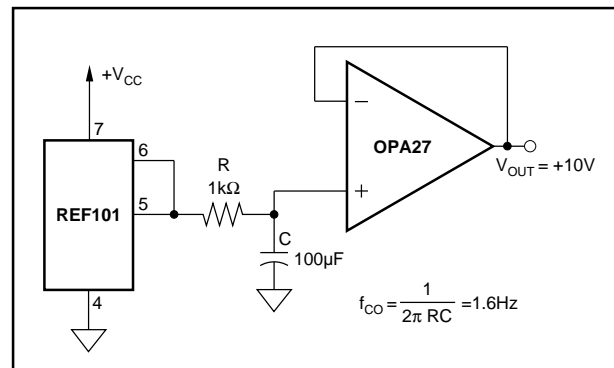

FIGURE 5. Precision Reference with Filtering.

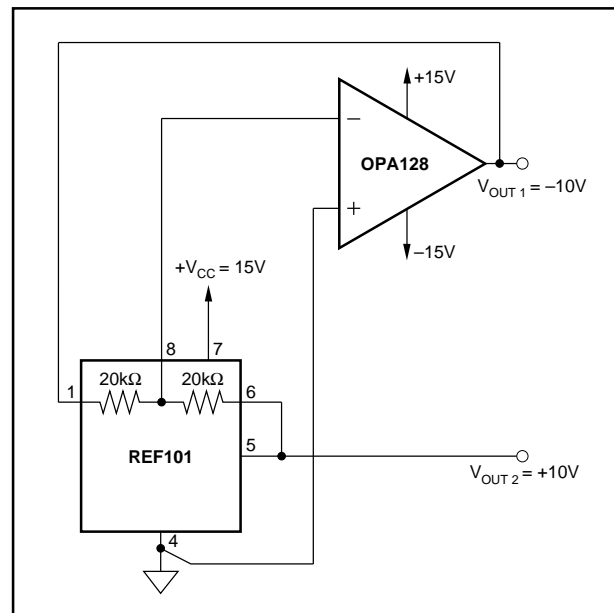

FIGURE 6.  $\pm 10\text{V}$  Reference.

The information provided herein is believed to be reliable; however, BURR-BROWN assumes no responsibility for inaccuracies or omissions. BURR-BROWN assumes no responsibility for the use of this information, and all use of such information shall be entirely at the user's own risk. Prices and specifications are subject to change without notice. No patent rights or licenses to any of the circuits described herein are implied or granted to any third party. BURR-BROWN does not authorize or warrant any BURR-BROWN product for use in life support devices and/or systems.

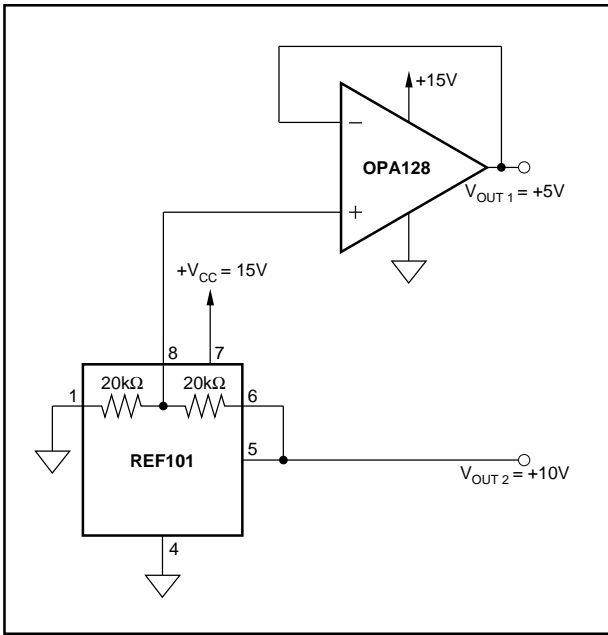

FIGURE 7. +10V and +5V Reference.

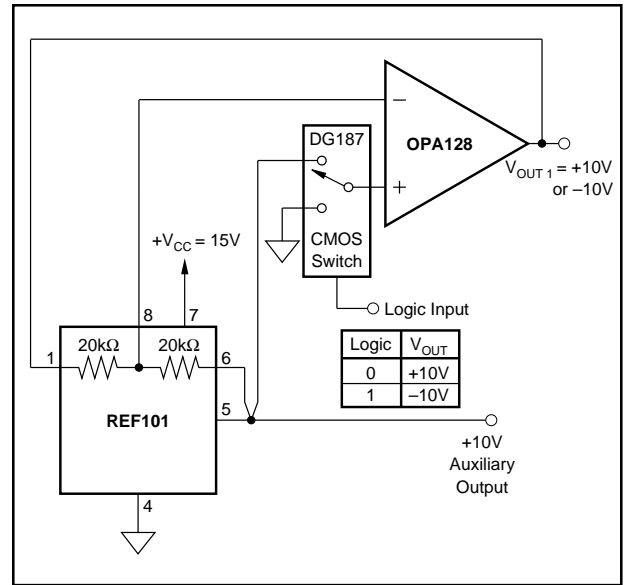

FIGURE 9. Digitally-Controlled Bipolar Precision Reference.

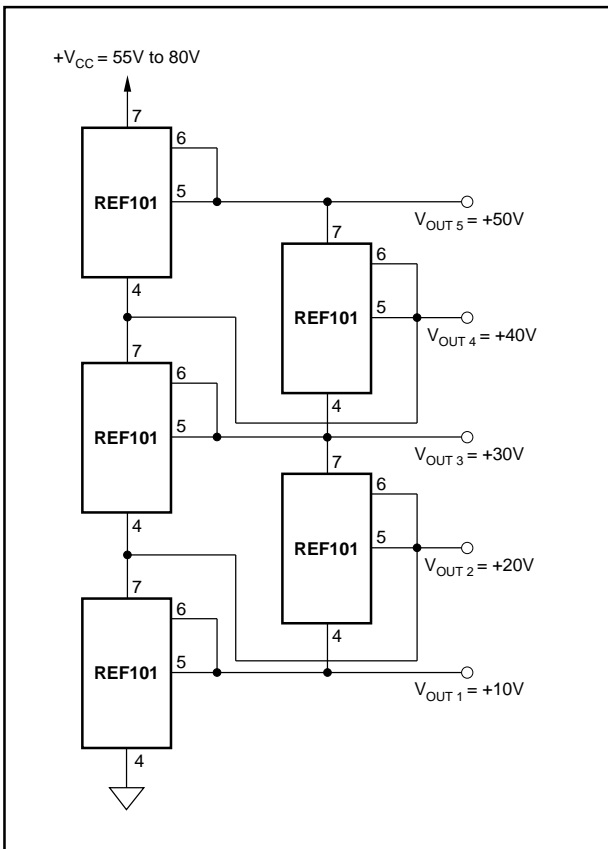

FIGURE 8. Stacked References.

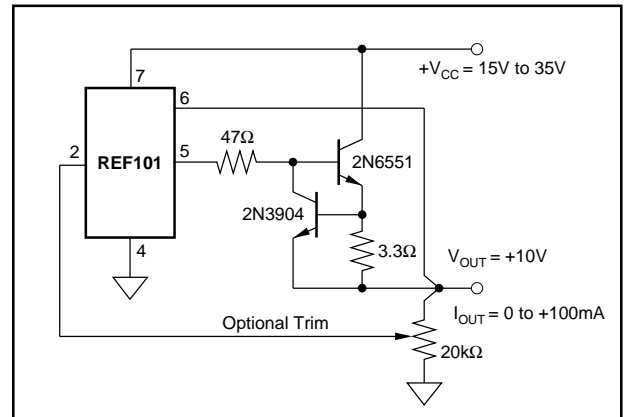

FIGURE 10. +10V Reference with Boosted Output Current to 100mA.

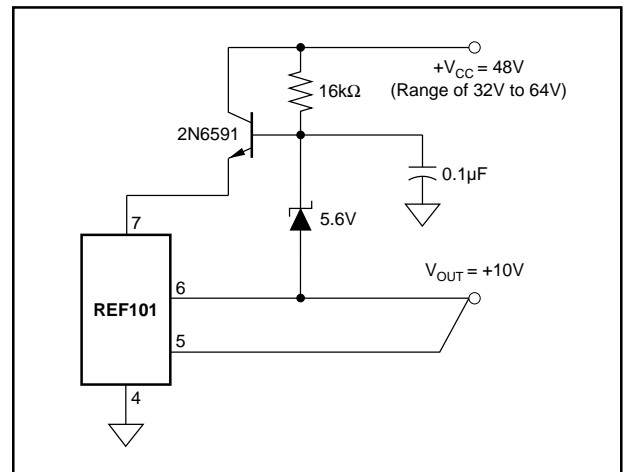

FIGURE 11. +10V Reference with Input Voltage Boost for 48V Operation.

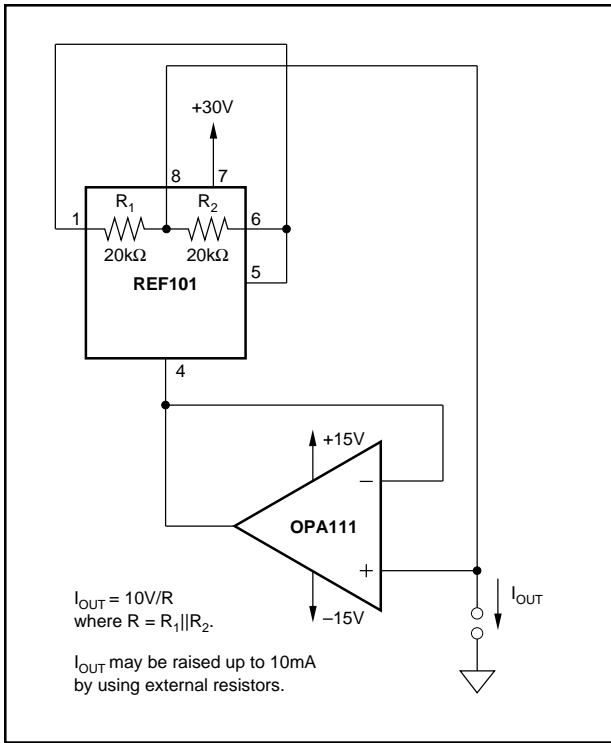

FIGURE 12. Positive Precision 1mA Current Source.

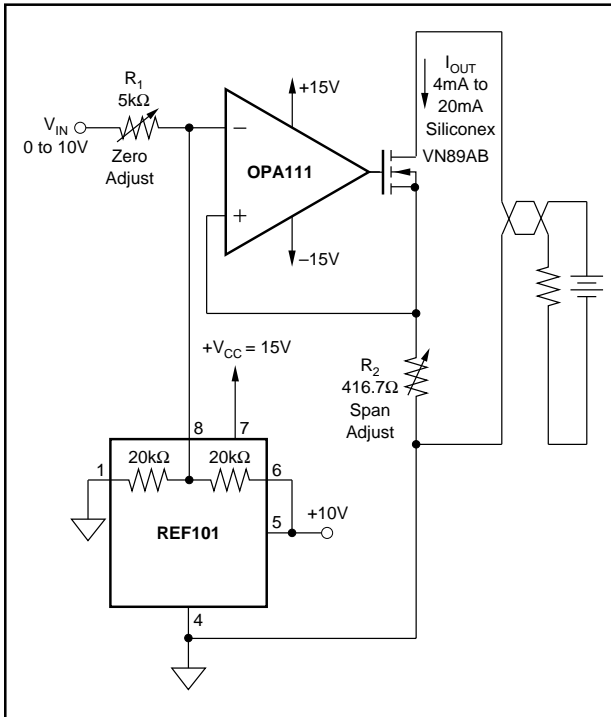

FIGURE 13. 4mA to 20mA Precision Current Transmitter.

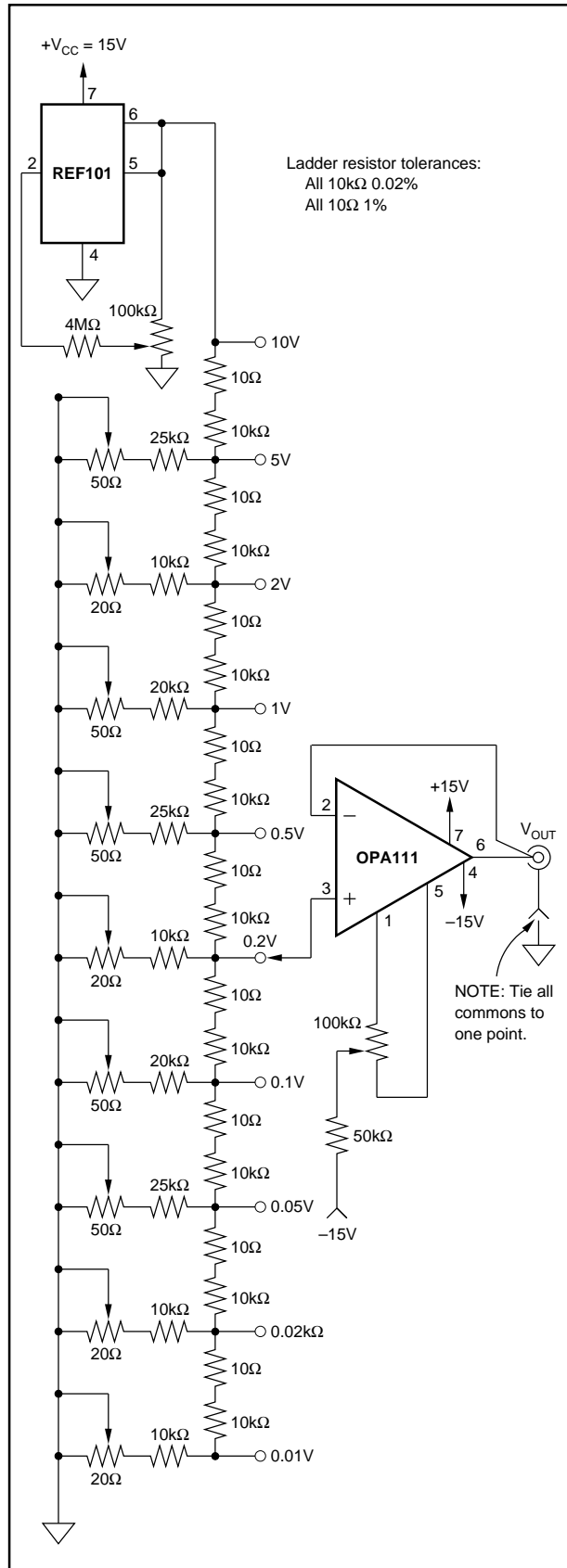

FIGURE 14. Precision Voltage Calibrator.



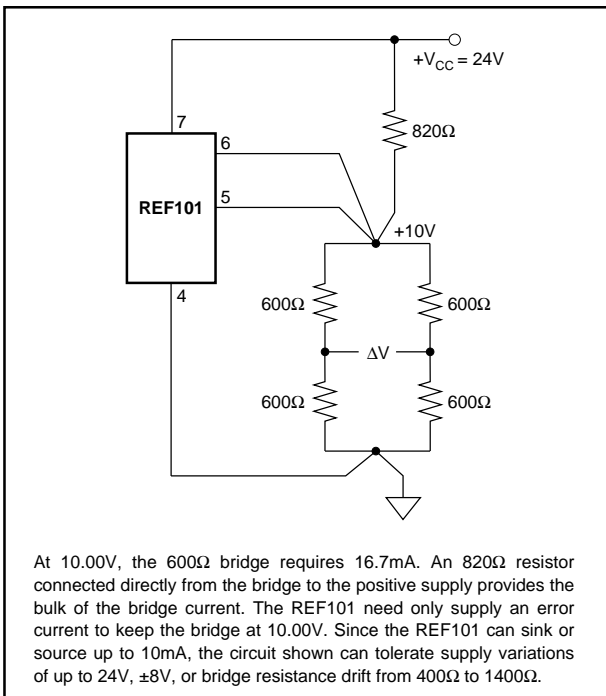

FIGURE 15. +10V Reference with Output Current Boost Using a Resistor to Drive a 600Ω Bridge.

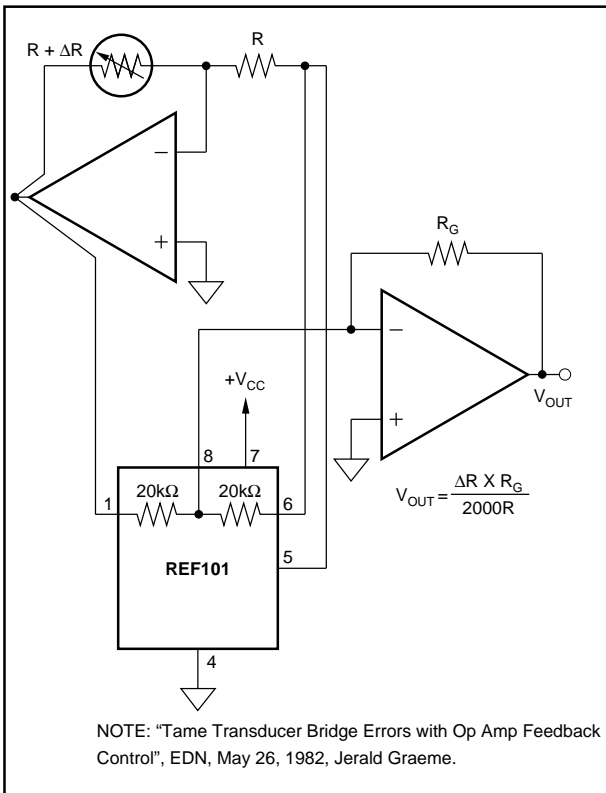

FIGURE 16. Linear Bridge Circuit Using Internal Precision Resistors of the REF101 as the Bridge Completion Network.

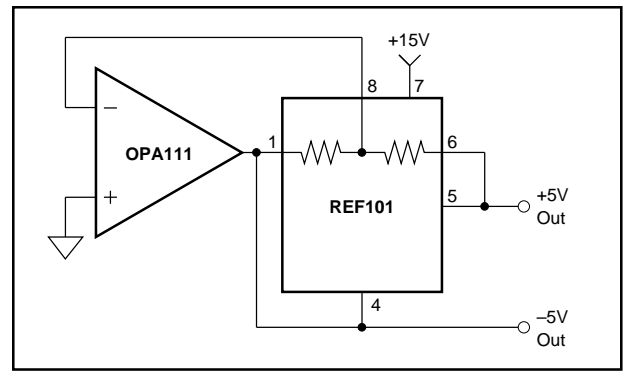

FIGURE 17. ±5V Reference.

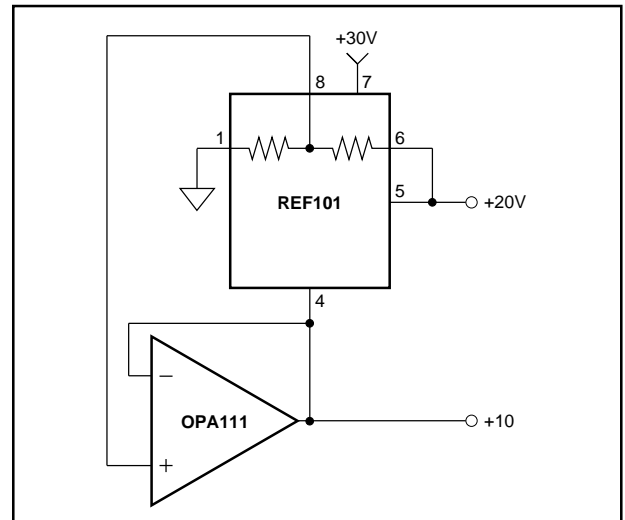

FIGURE 18. +10V and +20V Reference.

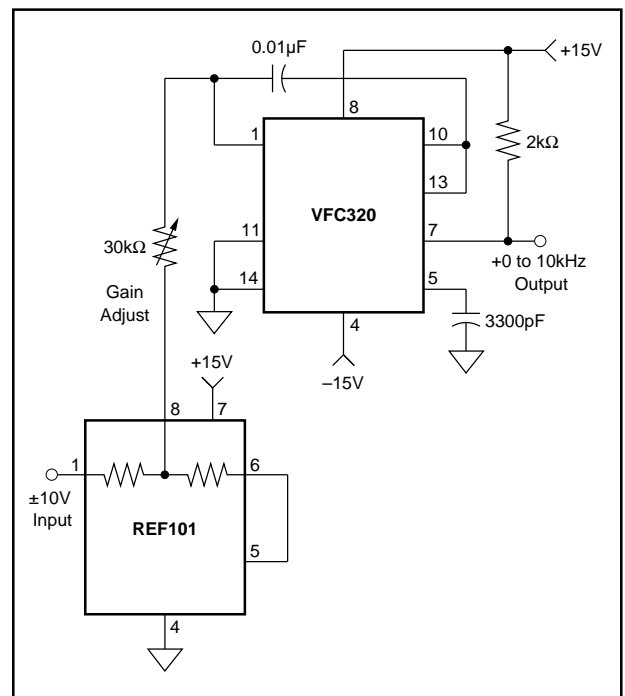

FIGURE 19. Bipolar Input Voltage-to-Frequency Converter.